

CHAPTER 3

GUNS

LIST OF CONTENTS

	<u>Para.</u>		<u>Para.</u>
Introduction	1	SERVICING	
DESCRIPTION AND OPERATION		General	23
General	2	Special tools and equipment	24
Gun package	3	Lubrication	25
Package locking mechanism	4	Ammunition tank and feed chutes	26
Gun fittings	6	Empty case and link chutes	27
Front mountings	7	Hot air valve..	28
Rear mountings	8	Removal of link containers	29
Barrel support	9	Gun package removal	30
Blast tubes	11	Loading package	31
Ammunition tank	12	Topping-up ammunition tanks	32
Feed chutes	13	Gun cocking	34
Link ejection chutes	14	Re-arming	35
Link containers	15	Harmonization	36
Cartridge case ejection chutes	16	REMOVAL AND INSTALLATION	
Cocking	17	General	37
Firing mechanism	18	Removing outboard guns from package	38
Air scoop	19	Installing outboard gun	39
Gun heating	20	Removing and installing inboard gun	40
Gun sight	21		
Camera gun	22		

LIST OF ILLUSTRATIONS

	<u>Fig.</u>		<u>Fig.</u>
Gun package lubrication	1	Gun fittings	4
Package locking mechanism	2	Gun front mounting	5
Rear mounting attachment bracket on outboard guns... ..	3	Port inboard gun rear mounting	6
		Barrel support alignment	7

RESTRICTED

Gun heating installation	<u>Fig.</u> 8
Hot air valve	9
Package removal (1)	10

Package removal (2)	<u>Fig.</u> 11
Ammunition flaking	12
Gun removal tool	13

WARNING

SUPPORT THE REAR FUSELAGE BEFORE REMOVING THE GUN PACKAGE FROM THE AIRCRAFT.

Introduction

1. This chapter contains a description of the gun package installation, together with information on the servicing of the package, including re-arming, removal and the re-installation of the guns. Information is also given on the gun sight and camera gun, but this is not dealt with in detail. The guns themselves are described in A.P.1641S, the gyro gun sight in A.P.1275E and the G.45 camera gun in A.P.1355D. The harmonization of the guns will be found in A.P.1661S.

DESCRIPTION AND OPERATION

General

2. The gun installation consists of four electrically fired and controlled 30 mm. Aden guns, which are carried, together with their ammunition, in a removable pre-armed armament package housed in the undersurface of the front fuselage. The gun barrels, which are detachable from the guns to allow removal of the package, extend forward under the cabin floor in blast tubes to apertures in the nose of the fuselage. The inboard guns are housed slightly forward of the outboard guns. The empty cartridge cases are ejected into the airstream through chutes extending aft from the rear of the gun package, two on each side, to apertures in the gun and radio access doors, while the belt links pass down chutes extending from the

guns to collector tanks fitted beneath the fuselage. The guns may be adjusted vertically and laterally for harmonization purposes. The armament package is heated by air conducted in pipes extending from the engine compressor. The flow of air is regulated by an electrically-operated valve controlled by a thermostat in the package. Whenever the guns are fired the gun package is automatically ventilated by the opening of small electrically-operated air scoop incorporated in the gun bay starboard access door. The guns are cocked pneumatically, before flight, from a ground supply and are fired by a trigger on the forward face of the control column handgrip. The Mk.5 gyro gun sight which is carried above the centre instrument panel on a Type 7 Mk.2 retractable mounting is used to sight the guns and the G.45 cine camera is located on a platform mounted in the fuselage nose structure and focused through a vision tube in the skin. The camera is operated whenever the guns are fired, but may also be operated independently if desired.

Gun package

3. The gun package is illustrated in fig.1. It consists of a removable structure designed to fit in a compartment in the underside of the front fuselage just forward of the radio bay with the

underside of the package continuing the fuselage line. The ammunition tank structure, which is removable, is carried on a platform at the top of the package. The package, complete with ammunition tank is supported in the fuselage by six spherical ended mounting spigots, which project downwards, three on each side, from the fuselage bottom longerons, to engage with sockets integral with the package. These mountings are locked by rack operated pins, which pass through holes in the spigots and sockets. The locking mechanisms are located on each side at the forward end of the package and are operated by a special removable key. The package is also provided with guide spigots at the forward end, which enter brackets attached to the bottom longerons before the main attachments engage. The package contains the front and the adjustable rear mountings in which the guns are carried. The ammunition feed chutes and belt link chutes, together with the heating and ventilating ducts, are also contained in this structure.

Package locking mechanism (fig.2)

4. The package locking mechanisms are located one on each side at the forward end of the package just aft of former A. Each assembly consists of a control box containing a key-operated shaft-driven pinion in engagement with racks at the ends of the locking rack bolt and rack bar, which enter the forward and rear faces of the control box respectively. These racks are held in contact with the pinion by small rollers and the top cover of the control box carries the package guide spigot. The pinion shaft, which is machined to a square section with a spherical end, extends to a keyhole bracket assembled to the skin of the package. The shaft carries a spring-loaded lock ring, which engages the keyways in the keyhole bracket in both the locked and unlocked positions. The rack bolt extends forward and is shaped to pass through the mounting socket and spigot at the

forward end of the package, while the rack bar extends aft and carries the locking bolts, which pass through the mounting sockets and spigots at formers C and E.

5. To lock or unlock the package the special key is inserted into the keyhole in the package skin and pressed in against the action of the spring to release the lock ring from engagement with the keyway in the keyhole bracket. Subsequent rotation of the key will turn the pinion, which in turn drives the rack bolt and rack bar to either insert or withdraw the locking bolts from the mounting spigots. Releasing the key at the limit of its travel will allow the lock ring to engage with the other keyway in the keyhole bracket.

Gun fittings (Fig.3 and 4)

6. A number of special fittings are assembled to each gun, which enable it to be mounted in the package. These fittings consist of rear mounting brackets, Dunlop A.C.O.7456 cocking adaptors, feed neck attachments and link chute attachments. The rear mounting brackets are bolted to the rear of the gun cradle; those for the outboard guns being positioned on the underside of the cradle (Fig.3) while those for the inboard guns (Fig.4) are located on the sides of the cradle and are thus of different design. One cocking adaptor is assembled to each gun, being located on the front face of the cradle. The feed chute attachments consist of two brackets positioned one on each side of the feed mouth in the feed casing, the feed chutes from the ammunition tank being attached to one bracket by spring-loaded pins carried on the feed chutes and located with the other bracket by a lug, also on the feed chute, which engages with a pip-pin on the bracket. The link chute attachments are in the form of locking bars, located on each side of the link

chute aperture in the gun, to which the link chutes are attached by rotation of the bars by means of a spring-loaded locking plate and lever assembly extending across the rear of the attachments.

Front mountings (Fig.5)

7. The gun front mountings are located at the front end of the package, those for the two inboard guns being carried in former A, while those for the outboard guns are in former B. Each mounting consists of a spherical bush, which is carried in a housing in the former and retained in position by a castellated ring screwed into the rear of the housing and locked by a special locking plate. The gun is supported in this mounting by a trunnion at the forward end of the gun cradle and the complete assembly is secured in position by the cradle nut, which is screwed on to the trunnion and locked by a lock washer. The front mountings are adjusted and locked on assembly, so that the spherical bush may just move in the housing and retaining ring to allow for gun harmonization.

Rear mountings

8. The gun rear mountings, which also form the harmonization assemblies are illustrated in fig.6, those for the inboard guns pick up with lugs integral with former D of the package, while those for the outboard guns pick up with similar lugs integral with former E. The inboard guns only, are provided with small adjustable tie rods extending from the bottom of former D to engage with the small rear mounting brackets on the cradles of these two guns. These rods must be disengaged before harmonization of the inboard guns, and after harmonization, the rods must be adjusted for length by slackening the locknuts and turning the barrel assemblies as required to allow them to pick up with the mounting brackets on the guns. Each rear mounting engages with the rear mounting brackets bolted to the rear of the gun cradle (para.6) and

the assembly consists of a traverse screw and locking sleeve extending between the lugs on the former of the package. This screw carries a threaded housing containing a worm driven eccentric assembly, which supports, by an attachment bolt, a stirrup shaped universal link for attachment to the gun. The traverse screw and locking sleeve assembly is, as its name implies, used to traverse the gun during harmonization. When the locking sleeve is slackened, rotation of the traverse screw will move the eccentric and housing assembly along the thread of the screw, thus traversing the gun according to the rotation of the screw. After adjustment, the locking sleeve must be re-tightened to lock the assembly. The eccentric assembly is employed, during harmonization, to elevate the gun to the required angle. The action being such that when the nut on the bolt passing through the adjusting worm in the centre of the eccentric housing is slackened off, rotation of the worm by its hexagon head will drive the eccentric round its housing thus elevating the gun according to the direction of rotation. After adjustment, the nut on the bolt through the worm must be re-tightened to lock the assembly.

Barrel support (Fig.7)

9. The detachable barrels of the guns are each supported in pedestal assemblies mounted on frames 10 and 11 below the cabin floor. These assemblies consist of flanged cylindrical machined stampings housing spherical bearings which are secured in position by knurled retaining rings, tightened so that the bearings are just capable of movement. The assemblies are identical with the exception of the spherical bearings, which for the outboard guns are fitted in the reverse position in the pedestals to those of the inboard guns.

10. Each assembly is mounted through holes in its flange to the appropriate frame by four studs. These attachments are adjustable to permit their

centralisation around the gun barrels after the guns have been harmonized. The barrel supports are secured at each stud by a soft metal washer interposed between a serrated washer and a serrated ferrule. The ferrule is a push fit into the hole in the flange and the assembly is secured by a special nut, which is wire locked. To adjust, unlock the special nuts and slacken them off, until it is possible to move the barrel support.

Blast tubes

11. The gun barrels are contained in the blast tubes extending from apertures in the nose of the fuselage to frames 10 and 11. The rear portions of these tubes, located between frames 9 and 10 for the outboard guns and frames 9 and 11 for the inboard guns, are integral with the fuselage and form part of this structure. The forward portions consist of tubes cut and flanged at their forward ends to conform with the oval apertures in the skin of the front fuselage. The rear ends of the tubes are fitted with a swaged ring containing a spring-loaded sealing ring secured by a special rivet. The tubes are secured in position by screws passing through their flanges to seatings on the fuselage skin and the sealing rings engage with seatings at the forward ends of the rear portions of the blast tubes.

Ammunition tank (Fig.1)

12. This is in the form of a removable box structure, which is provided with a floor and two removable lids. It is carried on a platform at the top of the gun package and is divided by a vertical transverse centre wall and longitudinal diaphragms to form four separate compartments in which the ammunition is carried. Each compartment is also provided with an inside wall adjacent to the longitudinal diaphragms which, with the diaphragms

form built-in feed chutes to engage with the removable feed chutes (para.13) and convey the ammunition to the guns. A roller is assembled at the top of each inside wall to guide the ammunition down the feed chutes and eliminate belt drag at this point. The ammunition tanks are secured to the gun package by six attachment brackets, three on each side which engage with forked lugs assembled on the ammunition platform and former E. The lugs on the platform are located just aft of former C and at the top of former D, the attachment at these points being made by means of bolts. At former E the attachment is made by pins locked by split pins. The two ammunition tank lids are hooked under four fork attachments riveted to the top of the longitudinal diaphragms and the lids are retained in the closed position by locking latch assemblies engaging with brackets on the outsides of the ammunition tanks.

Feed chutes (Fig.1)

13. The four removable feed chutes, one for each gun, extend from the built-in portions integral with the ammunition tanks (para.12) to the attachments on each gun (para.6). They are of welded stainless steel construction, being curved and formed so as to convey the ammunition to the guns in such a manner as to prevent excessive belt drag as the guns are fired. Each chute engages with its associated built-in portion and is attached to the gun fittings by a locking latch assembly. The chutes are also provided with small doors, which can be opened when it is necessary to break the ammunition belts.

Link ejection chutes (Fig.1 and 10)

14. The four link ejection chutes, one for each gun, extend from the link chute attachment fittings on the guns (para.6) to the link containers which

are fitted on the underside of the gun package. The main link chutes are of welded stainless steel construction, incorporating leaf springs and rail assemblies, which form a belt disintegrating device. The link chute extensions are also of welded steel construction, being retained in position by Dzus fasteners and small tongues which engage with the apertures in the gun package. Removal of the main link chutes is effected by first removing the link chute extensions by disengaging the Dzus fasteners and then withdrawing the main link chutes through the holes in the skin.

Link containers

15. The gun cartridge link containers, which consist of streamlined light alloy shells stiffened by internal structure, are fitted to the underside of the front fuselage, port and starboard. They are manufactured in two parts, the forward portion being attached to the gun package and readily detachable, while the rear portion is assembled as a part of the radio and gun bay access doors. The forward anchorage of the front detachable portion consists of a spigot on the container which engages with a screw contained in structure attached to former A of the gun package. The anchorage can be released after removing the access panel forward of the container. A stiffener fitted on the inside of the panel serves as a lock for the anchorage screw when the panel is assembled. Consequently, the panel cannot be re-fitted unless the anchorage screw is screwed fully home. The rear anchorage consist of mechanical locks on the container which engage with lock pins on former E of the gun package port and starboard. A plunger, which extends laterally across the rear of the container is in connection with the operating levers of the two locks. Depression of the plunger releases the locks which remain open until the container is re-fitted to the structure, when they automatic-

ally close again to engage with the lock pins. When both locks are fully closed, the plunger returns to its normal position i.e. flush with the surrounding structure of the container, which serves as an indication to the ground crew that the locks are effectively closed. Location of the one half of the container with the other is effected by means of a spring-loaded spigot attached to structure on the rear of the forward portion which engages with a slotted hole in structure on the forward face of the rear portion. A lever integral with the spigot is provided for withdrawal of the spigot when opening the radio and gun bay access doors.

Cartridge case ejection chutes (Fig.10)

16. The four cartridge case ejection chutes, one from each gun, are in the form of curved steel tubes, those for the inboard guns being in two portions. The chutes for the outboard guns have a flange welded to one end and an attachment bracket welded to the other. The flanged ends of the chutes enter spring-loaded sealing glands on the rear cover of the gun package and engage with the ejection tubes on their respective guns. The chutes extend aft and the attachment brackets at their extremities are anchored to brackets mounted on frame 19 by quick-release pins. The chutes, face extension chutes which project through and are integral with the radio and gun bay access doors. The forward portions of the chutes for the inboard guns are supported by the guns themselves and a tubular bracket on the rear cover of the gun package. The aft portion of the chute is attached to the radio and gun bay access door and is removed with the door.

Cocking

17. The guns are cocked pneumatically, while

the package is removed from the aircraft, by the use of a Dunlop cocking assembly supplied with compressed air at a pressure of 1,200 lb./sq.in., from a ground servicing trolley. The quick release coupling engages with the cocking unit adaptors fitted to each gun. The cocking valve must be operated three times to fully cock each gun. The cocking units on the guns are described in A.P.1641S. Access to the inner gun cocking units is gained by detaching the dished covers at the front of the package. The cocking units for the outer guns are beneath the gun package front cover, which is secured by Dzus fasteners.

Firing mechanism

18. The guns are fired electrically, through an electric firing unit on each gun, the firing operation being actuated by a trigger-operated switch located on the forward face of the control column handgrip. This trigger is provided with a safety catch in the form of a spring-loaded flap positioned over the camera gun push-switch at the top of the handgrip. The guns are also prevented from being fired, while the aircraft is on the ground, by micro switches, located one on each main undercarriage leg, which interrupt the supply to the firing trigger switch. The micro switches may, however, be 'cut out', when it is required to fire the guns at the butts, by use of a butt switch located on the cabin starboard shelf. The operation of the gun firing electrical circuit is described in Sect.5, Chap.1, Group G.1 of this volume and the firing mechanism in the gun is described in A.P.1641S, Vol.1.

Air scoop (Fig.10)

19. The gun package is ventilated whenever the guns are fired by air passing through an air scoop duct, which extends between the forward end of package and a shuttered aperture in the gun bay front starboard

access door. The air scoop duct consists of light alloys pressings welded together with a lipped angle extending along the top and an attachment bracket at the bottom. Two short lengths of tube are also welded to the aft pressing near the top. The lipped angle at the top of the scoop passes over an angle at the top of the front cover of the package, while the tubes engage in holes in this cover and the assembly is locked in position by a quick-release pin, which passes through the attachment angle and a bracket also mounted on the front cover. The scoop on the gun bay starboard access door is opened and closed by an electric actuator also mounted on this door, as described in Sect.5, Chap.1, Group G.1 of this volume.

Gun heating (Fig.8)

20. The gun package is heated by air taken from the engine compressor, the supply being automatically regulated by an electrically-operated hot air valve mounted on the forward face of frame 19 and controlled by a Type FHO/A/96 thermostat located in the gun package on the port side between formers C and D just below the ammunition box platform. From the connection on the engine compressor casing the hot air is conducted by a flexible hose to a system of pipe lines, which pass around and down the starboard aft face of frame 33, diagonally across the bottom of the fuselage and extend forward to the hot air valve (Fig.9) on frame 19. The outlet from this valve is a flexible hose, which extends forward to connect with the quick-release coupling on the rear cover of the gun package. The hot air is conveyed into the package by a heating duct extending from the rear cover to just aft of former C. This duct consists of a tube with a number of holes at its forward end. The operation of the electrical circuit controlling the gun heating installation is described in Sect.5, Chap.1, Group G.1 of this volume.

Gun sight

21. The guns are sighted by a Mk.5 gyro gun sight which is carried above the centre instrument panel on a Type 7, Mk.2 retractable mounting and provision is made for the fitment of a Mk.3 camera recorder. The supporting structure for the retractable mounting and the operation of its electrical circuit, together with that of the gun sight is described in Sect.5, Chap.2, Group 4 of this volume, while the gun sight itself is described in A.P.1275E, Vol.1.

Camera gun

22. A G.45 camera gun is located on a mounting platform installed in the fuselage nose structure just forward of frame 3 and is focused through a vision tube riveted around an orifice in the skin. The camera is operated whenever the guns are fired, but can also be operated independently if desired, by depression of the camera push-switch at the top of the control column handgrip. The operation of the electrical circuit controlling the camera is given in Sect.5, Chap.1, Group G.1 of this volume, while a description of the camera itself will be found in A.P.1355D, Vol.1.

SERVICING

General

23. The following paragraphs contain the general servicing necessary to handle the gun package, including the special tools and equipment required for these operations. Information on the removal of the package, harmonization of the guns and re-arming is also included. For information on servicing the gun itself, reference should be made to A.P.1641S. When servicing the installation all the standard safety precautions pertaining to Aden 30 mm. guns must be observed and the main electrical supply lead to the package must be disconnected before commencing operations. Particular care must also be taken not to damage the access doors, blast tubes or empty case and link chutes by careless handling. After servicing, ensure that all the access panels are replaced and properly secured.

Special tools and equipment

24. The following equipment will be required for the servicing and gun removal detailed in this chapter.

<u>Item</u>	<u>Stores Ref.</u>	<u>Part No.</u>	<u>Equipment</u>
1	26FX/95037	C.177141	Sling for gun package.
2	26FX/95036	B.177142	Lifting spigot for winch attachments (2 off).
3	26FX/95038	ARM.33200	Gun package trolley for gun firing tests and harmonization.
4	26FX/95054	ARM.92751	Gun package trolley and cradle for re-arming and harmonization.
5	4G/3360	-	Bomb loading hoists, Type C and No.4 attachment (3 off).
6	26FX/95157	A.193753	Front sight for package (L.H.).
7	26FX/95158	A.193754	Front sight for package (R.H.).

<u>Item</u>	<u>Stores Ref.</u>	<u>Part No.</u>	<u>Equipment</u>
8	26FX/95159	A.193755	Rear sight for package (R.H. and L.H. 2 off).
9	26FX/95161	A.192253	Sight alignment bar (front).
10	26FX/95162	A.192254	Sight alignment bar (rear).
11	26FX/95043	A.183955	Barrel catch key (4 off).
12	26FX/95150	B.192679	Barrel support centring tool.
13	27Y/5000	RS.181/45	Spanner for front mounting.
14	26FX/95044	B.183954	Package locking key (2 off).
15	26FX/95152	B.193839	Sight locking key.
16	26FX/95201	D.197310	Gun removing tool.
17	26FX/95153	B.196709	Spanner for gun front nut.
18	26FX/95154	B.199592	Belt removal tool.
19	27Y/2373	RS/181/32	Spanner for barrel support retaining ring.
20	-	B.199253	Tail strut.
21	7R/292	-	Gun aligning instrument.
22	7R/293	-	Case for item 21.

Lubrication

25. The gun package lubrication is indicated on fig.1.

Ammunition tanks and feed chutes

26. Apart from checking for damage the only servicing necessary to the ammunition tanks is to ensure that they are kept clean and dry. The feed chutes must also be kept clean and any burrs removed. The roller assemblies and locking pins must be lubricated (Fig.1) and a check made to ensure that they operate smoothly.

Empty case and link chutes

27. These must be kept clean and free from burrs. The locking pin assemblies must also be checked to ensure that they operate freely.

Hot air valve (Fig.9)

28. Whenever it becomes necessary to change either, the actuator or the valve of the hot air valve assembly in the gun heating system the following tests should be made to ensure correct assembly of these components:-

(1) When fitting the actuator to the valve care

should be taken to ensure that the actuator driving pin engages correctly with the valve spindle. The two components should slide together freely without any force being applied to the driving spindle owing to malalignment. Malalignment may cause damage to the actuator and increase valve gland leakage.

- (2) With the valve closed, apply an air pressure of about 75 lb. per sq.in. to the end inlet connection. This should be carried out before and after assembly to the actuator to check that gland leakage has not increased.
- (3) With a suitable Breeze plug and switch, connect the actuator to a 24 volt supply. With pressure applied, open and close the valve over its full range by means of the actuator.

Removing link containers

29. The link containers should be removed as follows:-

- (1) Withdraw the spigot locating the two halves of the container and remove the radio and gun bay access doors complete with rear portion of container.
- (2) Remove the access door forward of the front portion of the container and unscrew the locking screw of the front anchorage, at the same time supporting the container.
- (3) Depress the plunger on the rear of the container to release the mechanical locks and remove the container.

Gun package removal (Fig.10 and 11)

30. The following operations will require three men to handle the hoists when lowering the package. It is desirable that the lowering instructions shall be given by the man handling the forward hoist.

- (1) Set the gun firing control to SAFE and the butt test switch to OFF.
- (2) Remove the link containers, port and starboard (para.29). Remove the front and rear access panels. Disconnect the power supply to the air-scoop and remove the air-scoop duct.
- (3) Remove the ejection tubes from the rear of the gun package.
- (4) Disconnect the flexible gun heating tube at the rear of the package.
- (5) Disconnect the power supply socket at the rear of the package.
- (6) Unlock the barrels with the aid of the barrel catch keys, rotate and slide the gun barrels forward, clear of the pack. Remove the catch keys.
- (7) Insert the lifting spigots in the sides of the fuselage and attach the side hoists, position the sling under the package and winch up tight.
- (8) Attach the forward hoist and winch up tight.
- (9) Position the cradle under the gun package.
- (10) Fit the tail strut (Part No. B.199253).

NOTE...

'The tail strut must be allowed to hang freely. Under no circumstances is the strut to be used as a permanent support by fitting blocks between the base of the strut and ground, neither is it to be removed until a package is installed or, failing that, until the aircraft has been adequately ballasted to compensate for the loss of the package.'

- (11) Unlock the gun package with the package keys, remove the keys and lower the package on to the cradle.
- (12) If the gun barrels have to be removed, stow them on the racks provided on the cradle.

Loading package

31. The initial loading of the package will be carried out with the package on a cradle. Ensure that the package is fully serviceable and that all electrical tests have been carried out, then proceed as follows:-

- (1) Remove the front and rear access panels of the package and load the ammunition tanks as required. Full instructions for making up belts of ammunition are contained in A.P.1641S, Vol.1, Part 1, Sect.6. The correct flaking sequence is shown in fig.12 and flaking and loading instruction plates are also contained in the ammunition tanks.
- (2) When the ammunition tanks have been filled but before the top layer of ammunition is finally positioned, the leading edge of the belt, that is the end with the loop, is inserted into the chute until it passes through the chute, enters the mouth of the feed mechanism and is positioned against the sprocket.

- (3) Load the gun as laid down in A.P.1641S, Vol.1, Part 1, Chap.8.
- (4) The top layer of ammunition can now be laid in position so that the lid of the ammunition tank, when closed, does not foul the ammunition.
- (5) Repeat the loading sequence for the remaining guns, replace the front and rear access panels and ensure that the ammunition tank lids are securely locked.

Topping up ammunition tanks

32. When a tank is partially empty the ammunition may be removed from the tank without being disengaged from the gun. The number of rounds may then be counted and a further length of belt added. If a known quantity of rounds have been fired the belt can be broken near the rollers and the correct length of belt inserted.

33. If a tank has to be reloaded when a short length of belt remains, the end of which is below the tank rollers, then the gun must be unloaded in accordance with A.P.1641S, Vol.1, Part 1, Chap.8, using the belt unloading hook when necessary. The hook should be used when the belt is too long to be withdrawn through the ammunition chute access panels and yet too short to be retrieved from the top of the ammunition tank chute. The remaining belt, during the unloading, should be withdrawn firmly and smoothly. Any jerking can disconnect the trailing links, which may necessitate the removal of the ammunition link chutes and the feed mechanism.

Gun cocking

34. For information on cocking the guns, reference

should be made to para.17 of this chapter.

Re-arming

35. Prior to re-arming, ensure that the gun firing control is set to SAFE, that the BUTT TEST switch in the cabin is OFF and that the guns have been cocked. If the gun barrels were removed, they must be re-inserted in the barrel supports. Proceed as follows:-

- (1) Move the cradle bearing the package under the package bay.
- (2) Insert the port and starboard winch spigots.
- (3) Attach the three hoists to the aircraft and connect the hoist cables to the gun package sling and the attachment point at the forward end of the package.
- (4) Winch up the package, under control, from the operator of the forward hoist, and during hoisting, check that the package does not foul the electrical wiring cables etc.
- (5) When the package is correctly home, lock the package to the fuselage from both port and starboard sides, using the package locking keys.
- (6) Remove the hoists, sling and cradle.
- (7) Insert the gun barrels in the breech cylinder housings. (A long thin slot is cut along the outside of the barrel to facilitate assembly of the barrel to the gun). When inserting the barrel into the breech cylinder housing, the slot should be on top in relation to the gun itself. This position is indicated by a diagram at the front of the package. Rotate the barrels and ensure that

they are securely locked.

- (8) Insert the cartridge case ejection tubes in the rear of the package and secure them to the airframe structure.
- (9) Attach the flexible gun heating tube to the rear of the package.
- (10) Connect the power supply socket to the rear of the package.
- (11) Position the air scoop duct at the forward end of the package.
- (12) Offer up the front access panels and connect the power supply to the air scoop. Secure the front panels.
- (13) Offer up and secure the rear access panels.
- (14) Replace link containers (para.29).

Harmonization

36. The harmonization of the guns is to be carried out in accordance with the instructions given in A.P.1641S, Vol.1, Part 1.

NOTE...

Before commencing to carry out any traverse adjustments, to the guns at the rear mountings, it is essential to withdraw the split pin and slacken off the 5/16 in. nut on the locking bolt through the Eccentric Adjusting Worm (Part No. F.205197).

Gun firing at the butts

36A. Prior to gun firing at the butts, and until the incorporation of Mod.573, the nose wheel front door must be retracted and secured as follows:-

- (1) Fit undercarriage safety locks (Sect.2, Chap.1).
- (2) Disconnect vertical operating rods (Sect.3, Chap.5, fig.7, item 4) where they attach to the cross shaft levers.
- (3) Retract the door and check that the locks are fully home.
- (4) Swing the disconnected rods down towards the door and secure by two turns of locking wire to the rods operating the locks.
- (5) Smear the outside of the door and local structure, in way of gun blast, with a suitable protective grease.

REMOVAL AND INSTALLATION

General

37. Both outboard guns can be removed from the package, or installed without removing the adjacent guns, but dependent upon the harmonization position of the inboard guns, it may be necessary to slacken off the gun cradle locknut (fig.5) and partially withdraw an inner gun in order to remove the rear mounting bolt from the opposite inboard gun.

Removing outboard gun from package

38. This operation should be carried out with the package on the cradle.

- (1) Ensure that the gun is unloaded.
- (2) Remove the front and rear package cowlings.
- (3) Remove the extension ejection tubes from the inboard guns.

- (4) Unplug the firing unit plug from the package socket.
- (5) Disconnect and remove the feed chute.
- (6) Disconnect and remove the package link ejection panels.
- (7) Disconnect and remove the link chute.
- (8) Unlock and remove the gun cradle lock-nut.
- (9) Insert the barrel to assist in the gun removal.
- (10) Remove the return springs from the rear of the gun.
- (11) Insert the gun removing tool in the cradle (fig.13) ensure that the handle is horizontal.
- (12) Unlock and remove the rear mounting bolt. It is advisable for the weight of the gun to be taken by the gun removing tool during this operation.
- (13) Withdraw the gun from the package, taking care that the electrical supply lead and the cradle contact leads do not foul any part of the structure. Similarly, take care to avoid striking the "gun loaded" indicator against the package ribs. The indicator is fragile and very easily damaged.

Installing outboard gun

39. With the barrel fitted, the return springs removed from the rear of the gun and the gun removing tool in position (fig.13), proceed as follows:-

- (1) Lift the gun into the package so that the

barrel passes through the front mounting bearing, ensuring that the firing unit cables do not get crushed between the gun and the package frames, and that the "gun loaded" indicator is kept clear of the package structure.

- (2) Ensure that the gun cradle is correctly positioned in the front mounting bearing and then remove the gun barrel.
- (3) Engage two or three threads of the cradle lock-nut.
- (4) Lift the gun at the rear so that the rear mounting bracket is correctly positioned and assemble the rear mounting bolt.
- (5) Tighten the cradle lock-nut.
- (6) Tighten and wire-lock the rear mounting bolt, using the protective cap (Part No. F.214617) over the threaded end of the bolt during insertion of the bolt and removing it after the bolt is in position.
- (7) Replace the link chute.
- (8) Replace the package link ejection panels.
- (9) Replace the feed chute.
- (10) Remove the gun removing tool and insert and secure the return springs.

- (11) Replace the extension ejection tubes for the inboard gun.
- (12) Connect the firing unit lead plug to the package socket.
- (13) Carry out electrical continuity tests.
- (14) Replace the front and rear access panels.

Removing and installing inboard gun

40. As previously mentioned, when removing an inboard gun it may be necessary to disturb the other inboard gun in order to remove the rear mounting bolt.

41. During the removal of an inboard gun it is only possible to disengage and move the link chute away from the gun, not to remove the chute completely. This is only possible when the gun has been removed from the package. Thus, prior to the installation of the gun, the link chute must be placed in the link chute opening of the package.

42. The rear of the inboard gun cradles are connected to the gun package by two tie rods (fig.6) which must be disconnected before gun removal and reconnected, adjusted and locked after the gun is installed.

43. Apart from the items mentioned above, the procedure for removal and installation of the inboard guns is similar to that for the outboard guns.

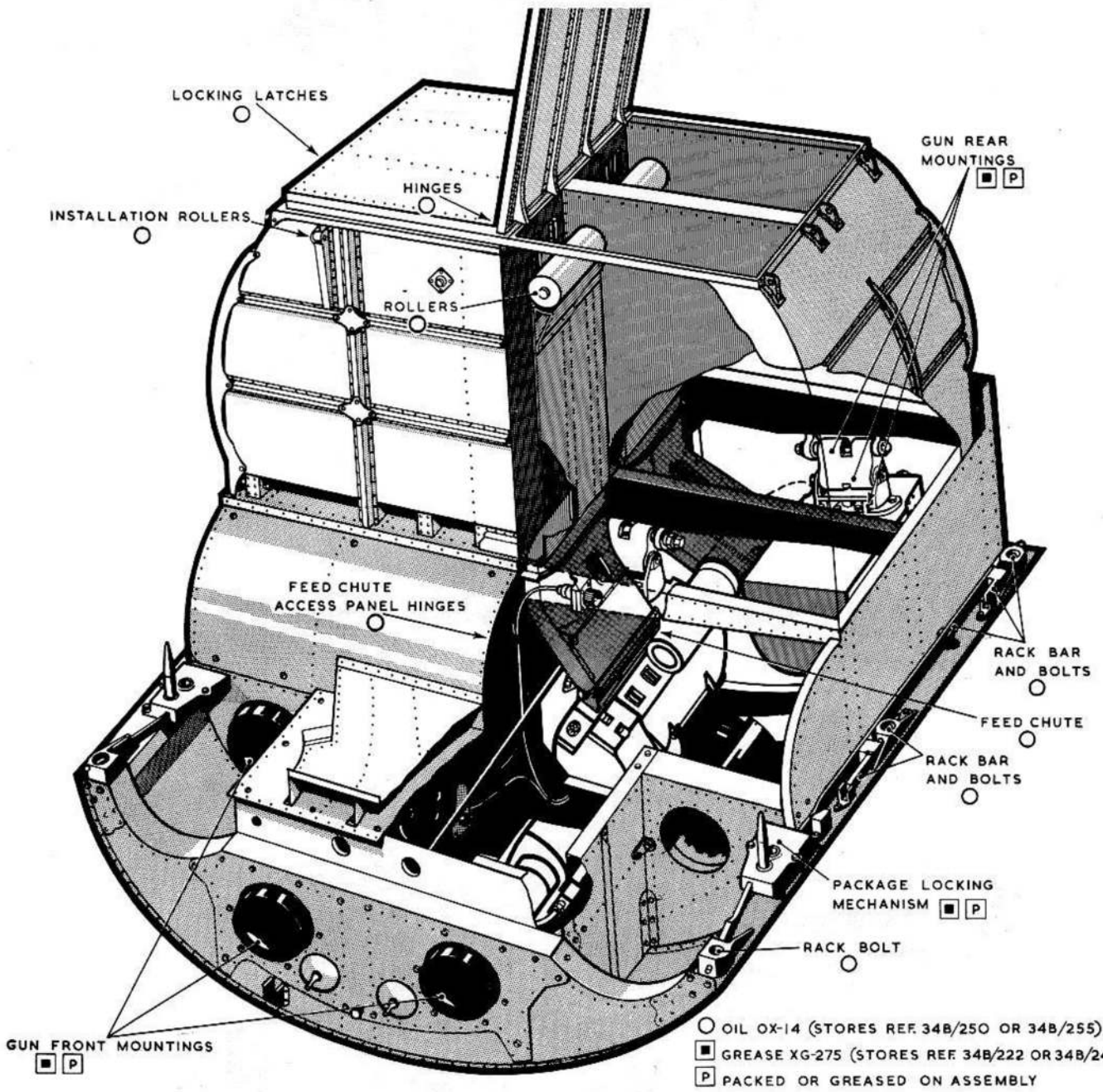

FIG.1 GUN PACKAGE LUBRICATION

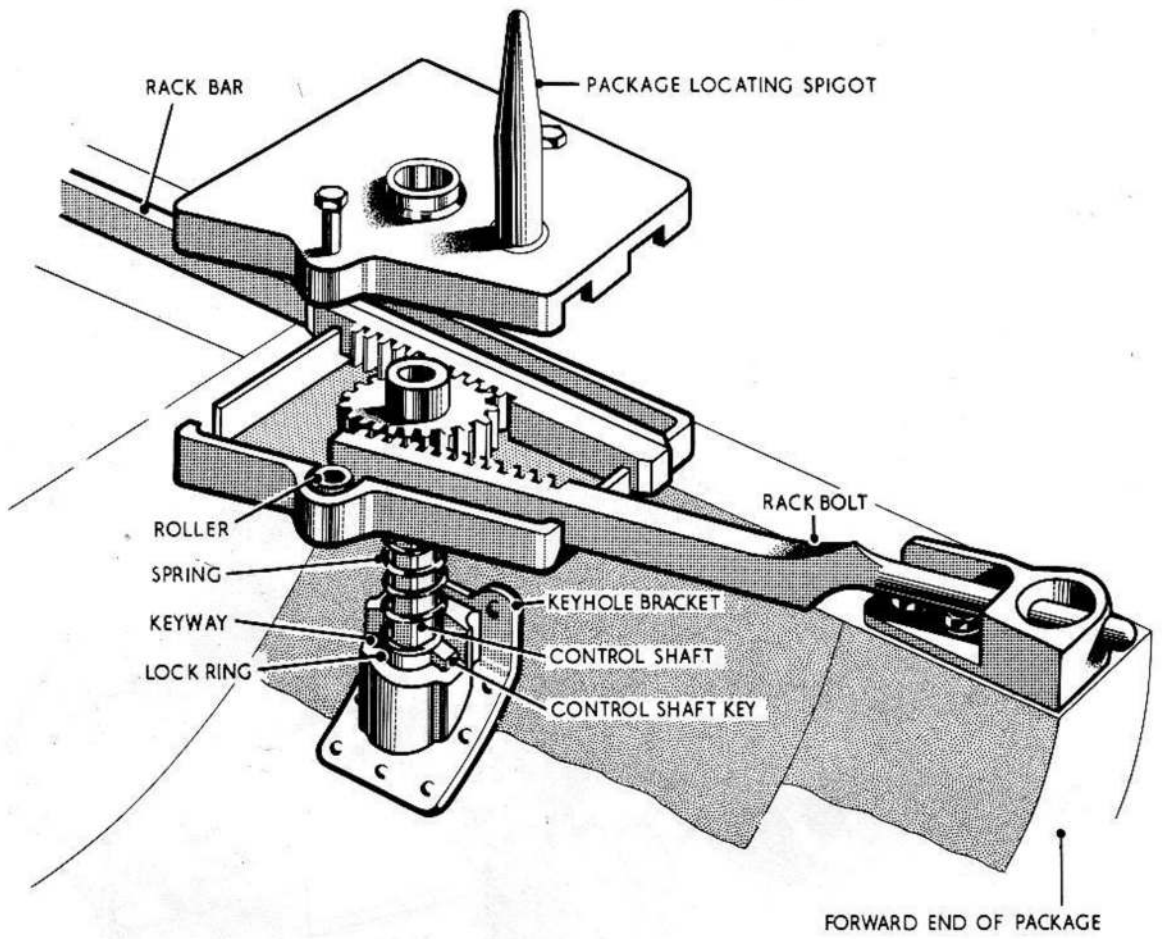

FIG. 2 - PACKAGE LOCKING MECHANISM

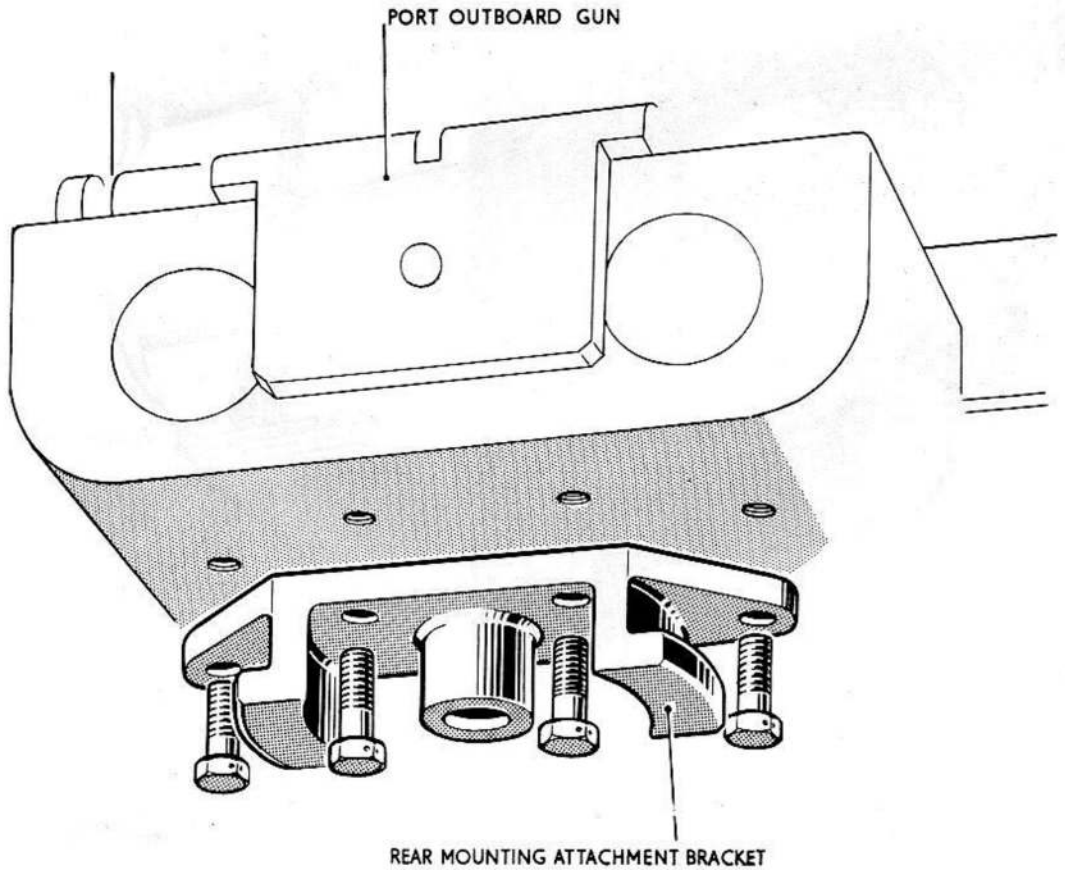

FIG. 3 REAR MOUNTING ATTACHMENT BRACKET ON OUTBOARD GUNS

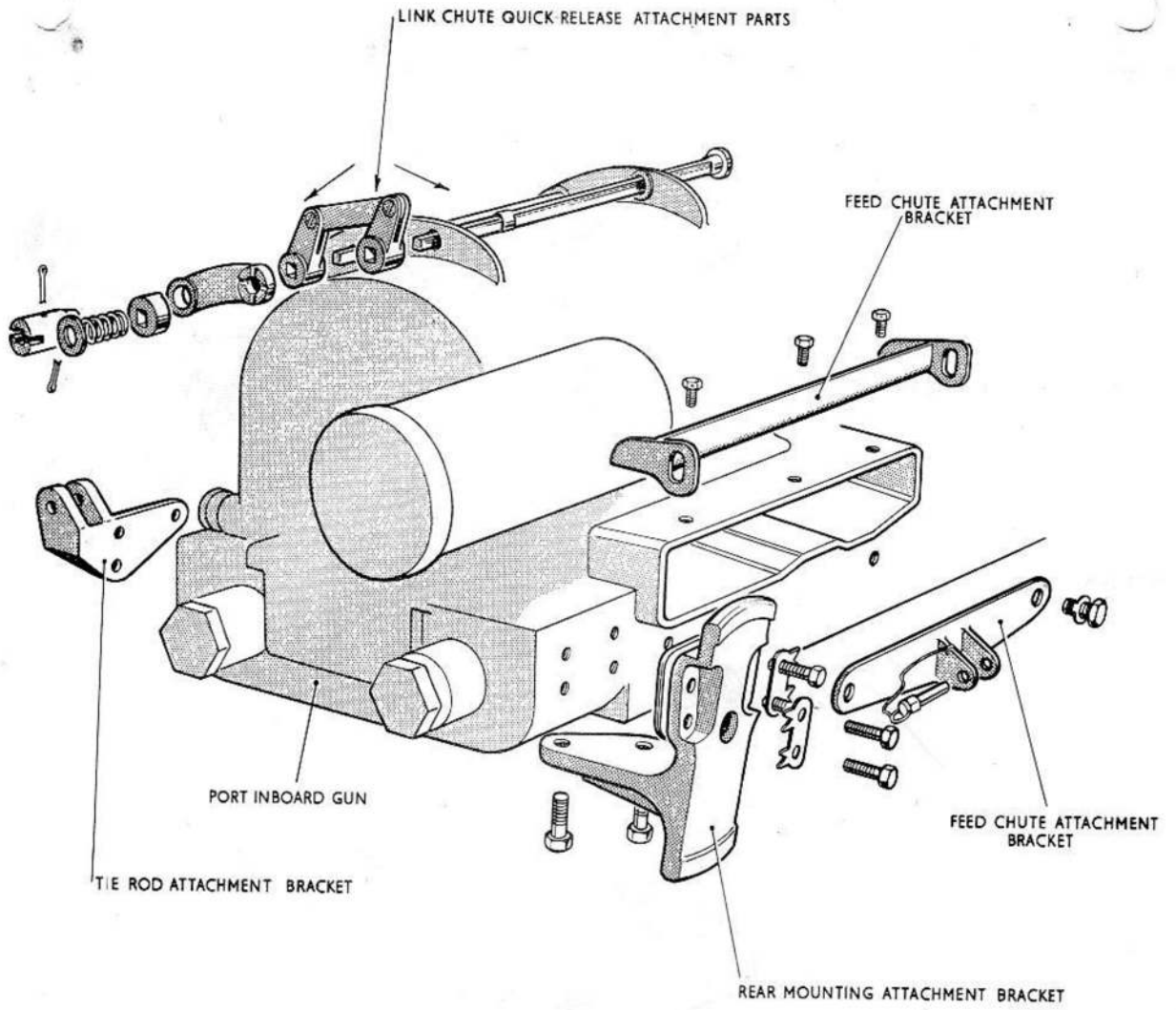

FIG.4 GUN FITTINGS

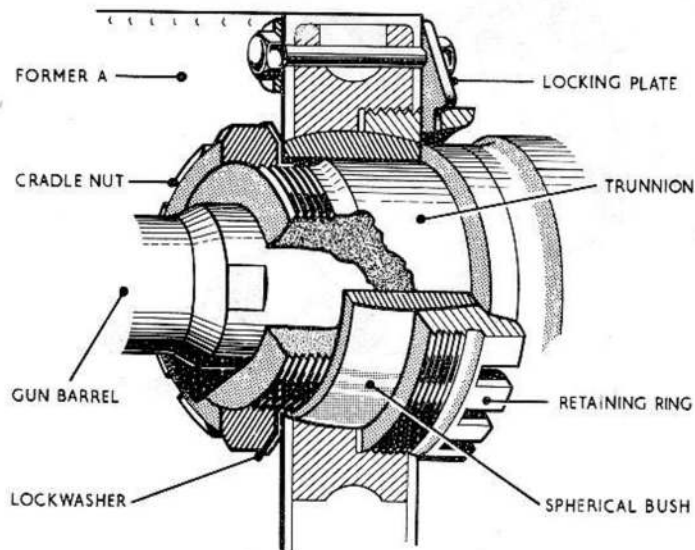

FIG.5 — GUN FRONT MOUNTING

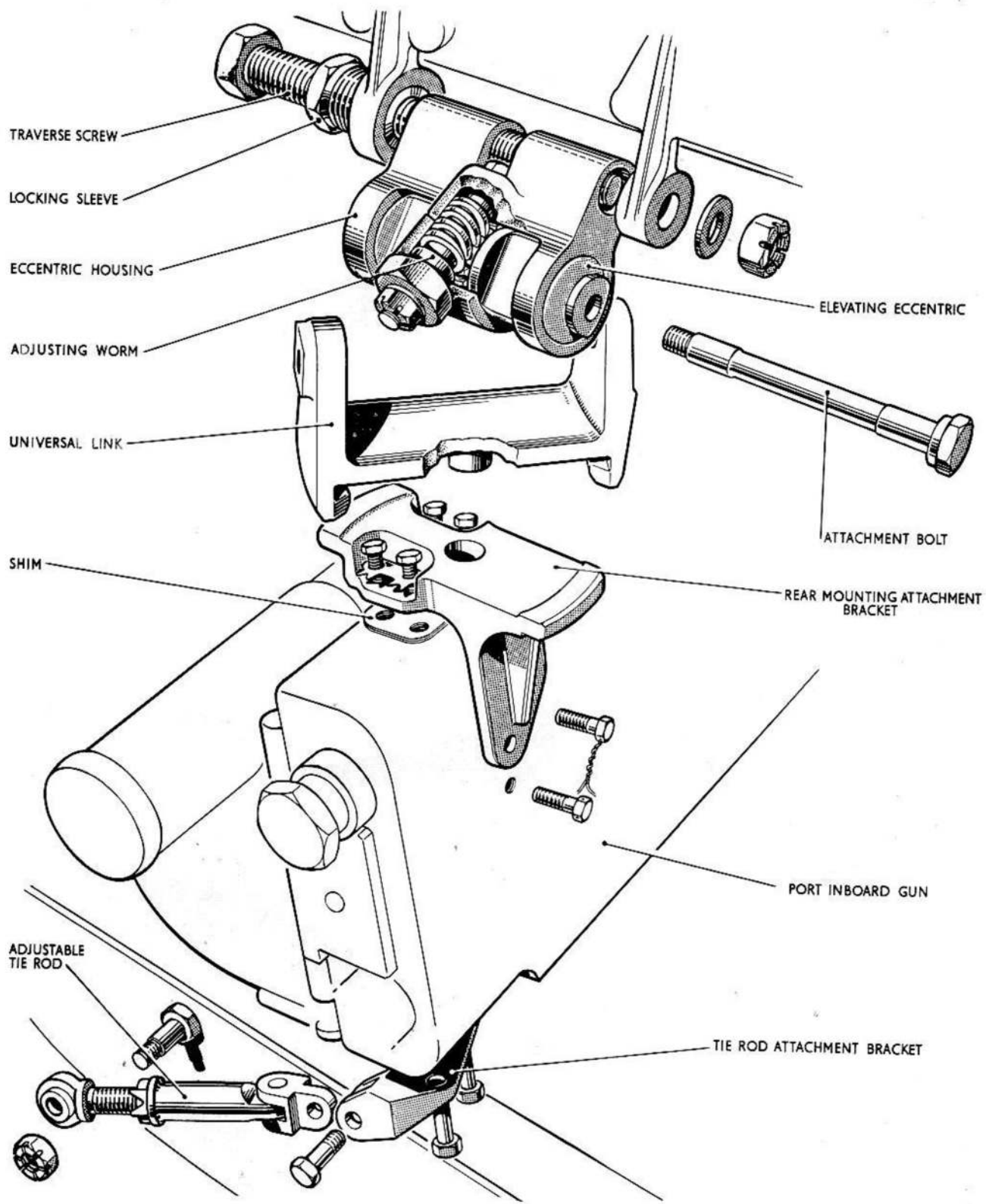

FIG. 6 PORT INBOARD GUN REAR MOUNTING

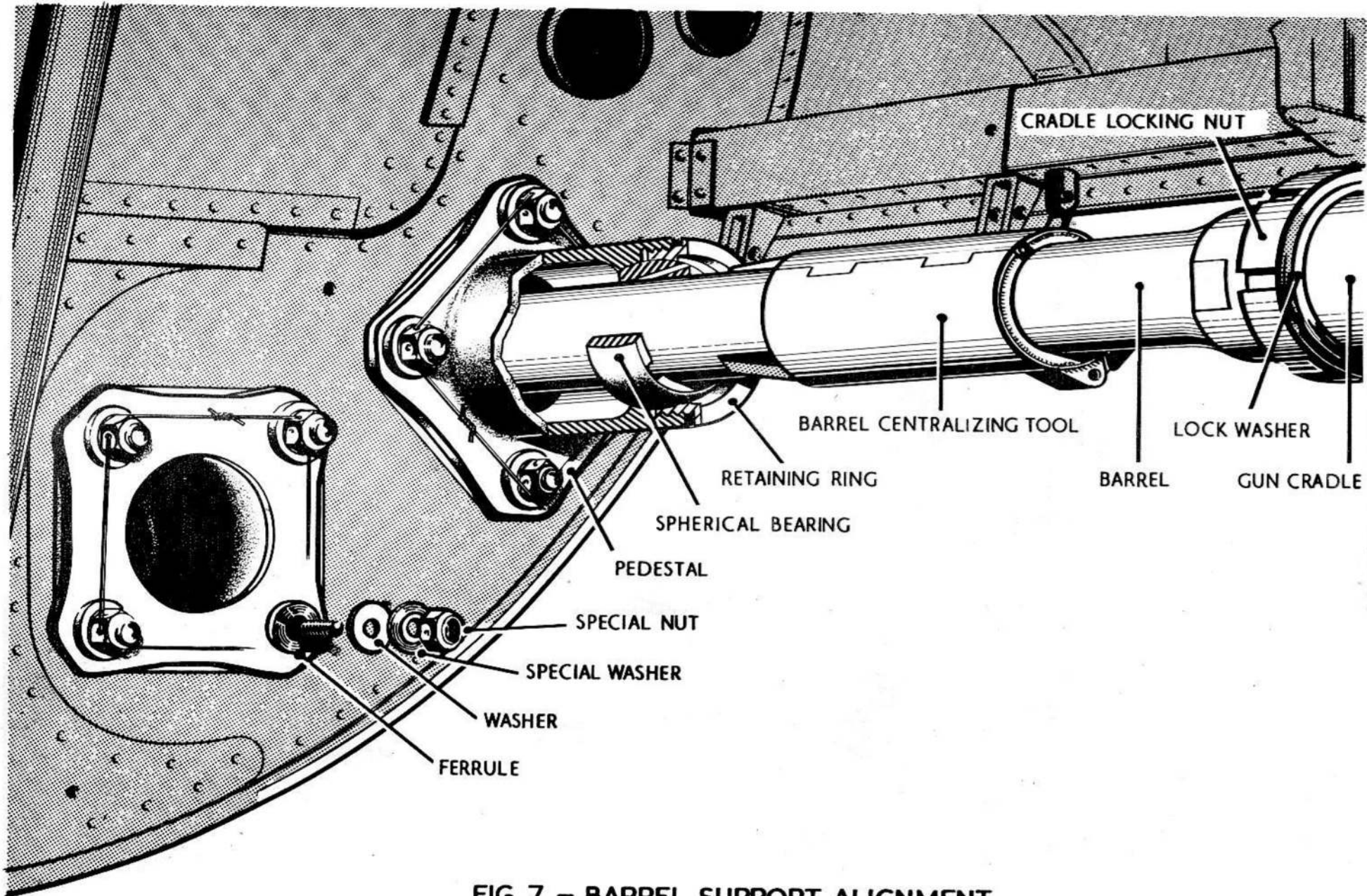

FIG. 7 - BARREL SUPPORT ALIGNMENT

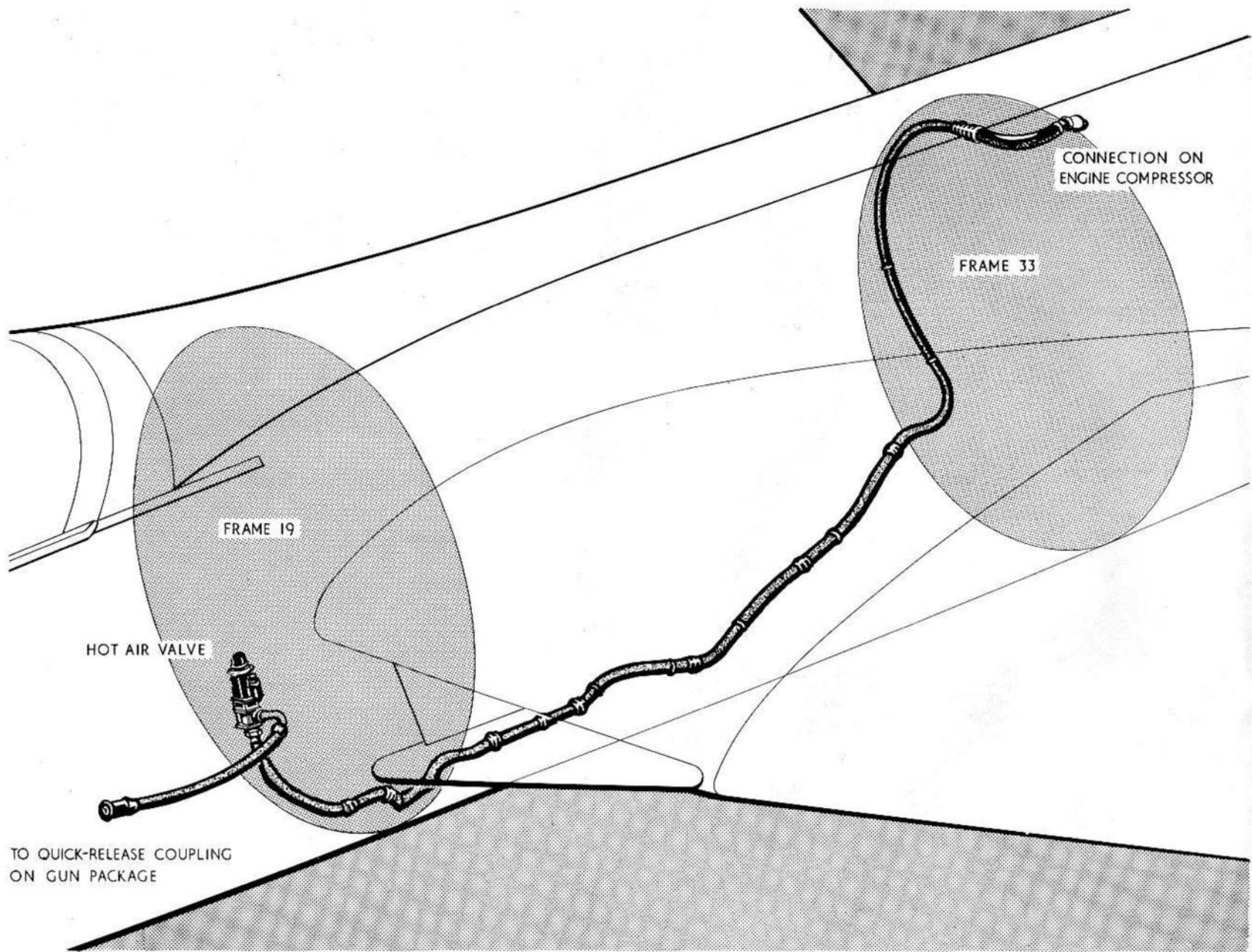

FIG.8 - GUN HEATING INSTALLATION

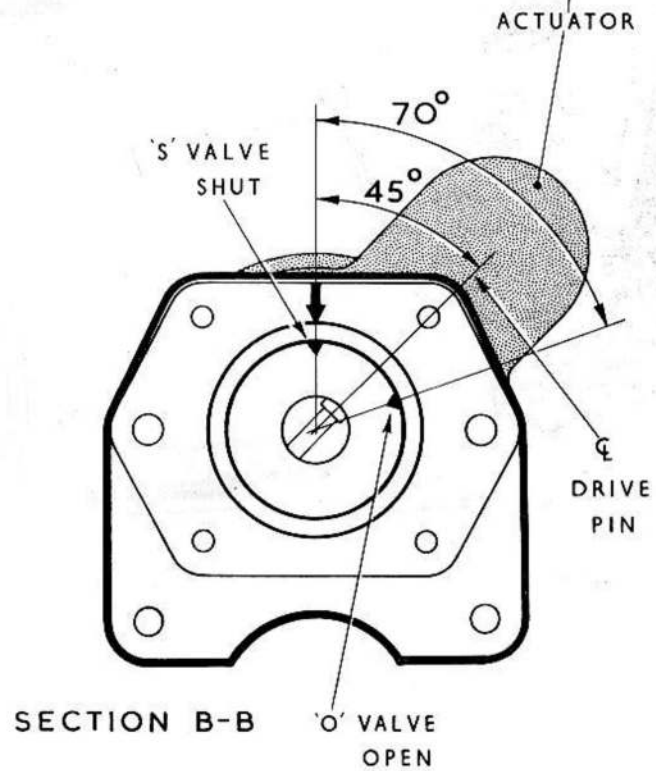
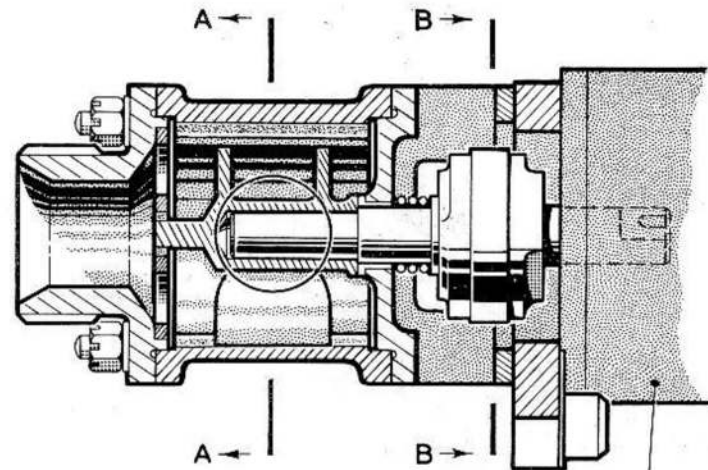
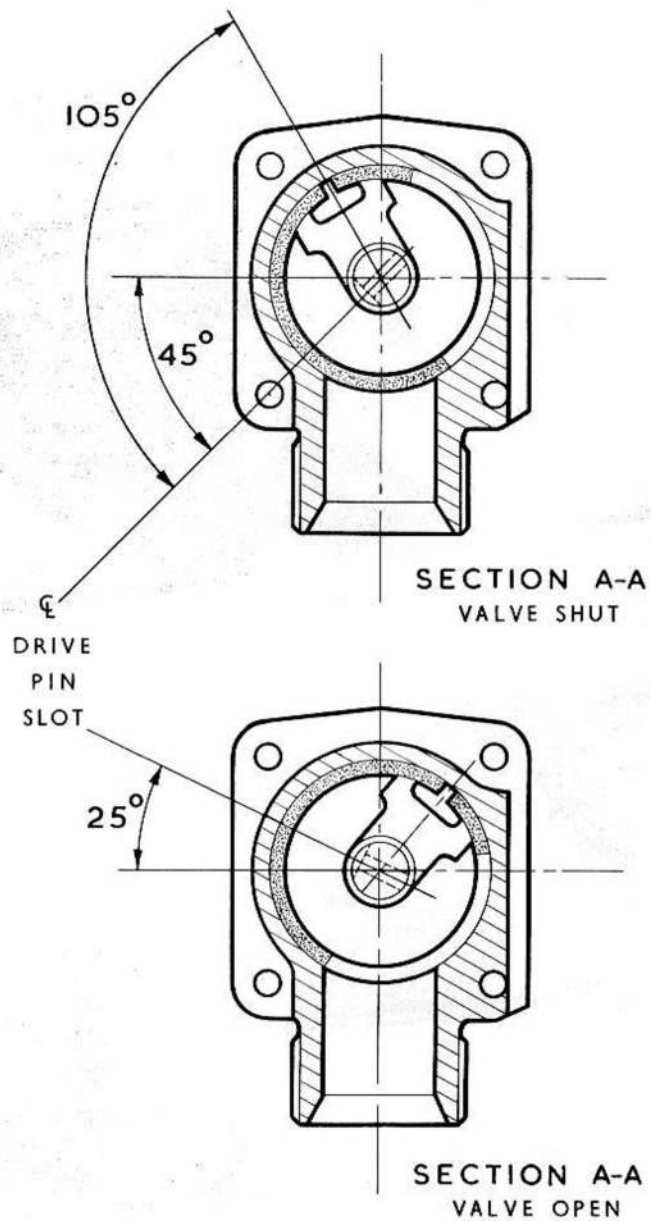

FIG.9 HOT AIR VALVE

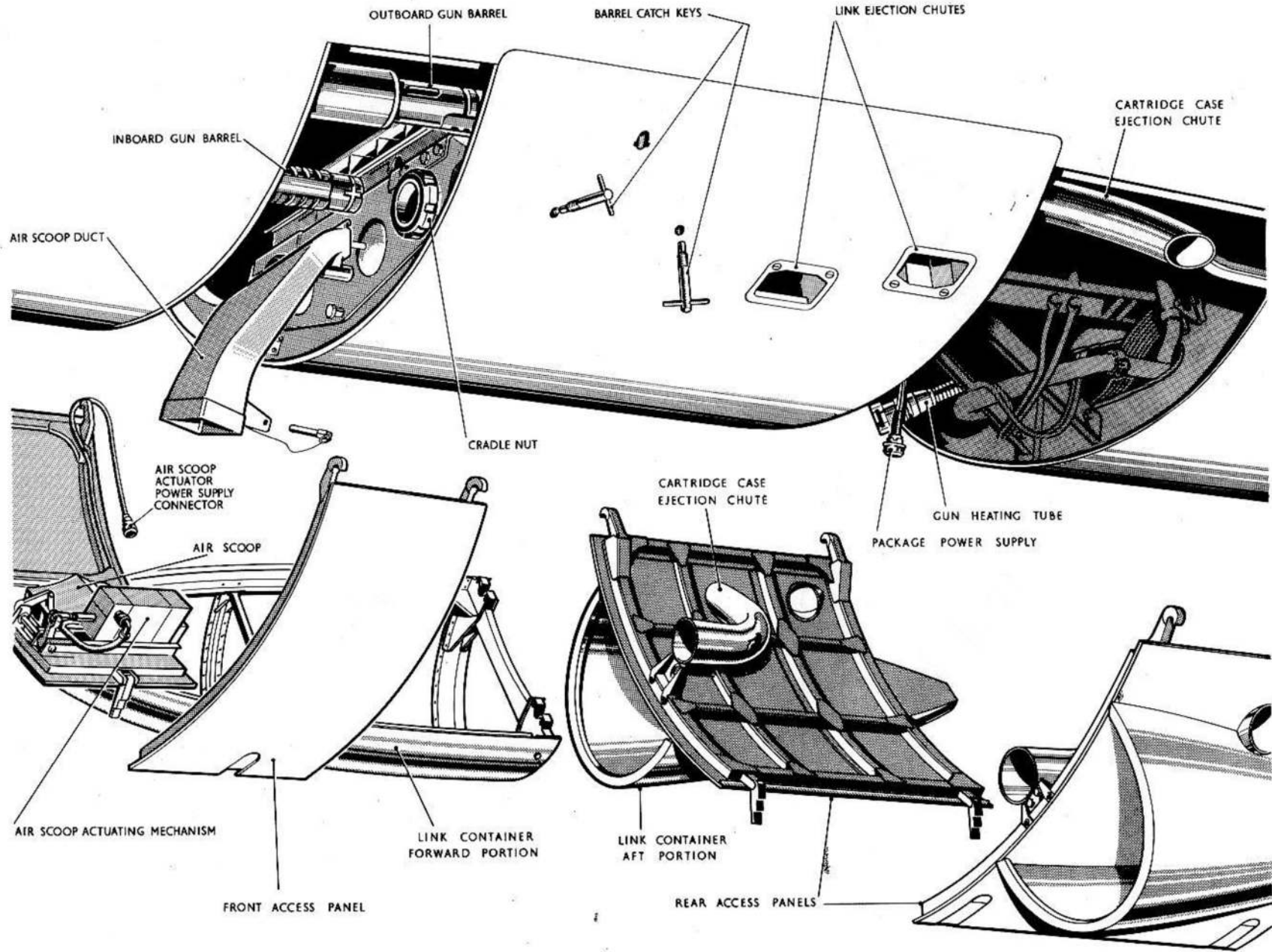

FIG.10 PACKAGE REMOVAL (I)

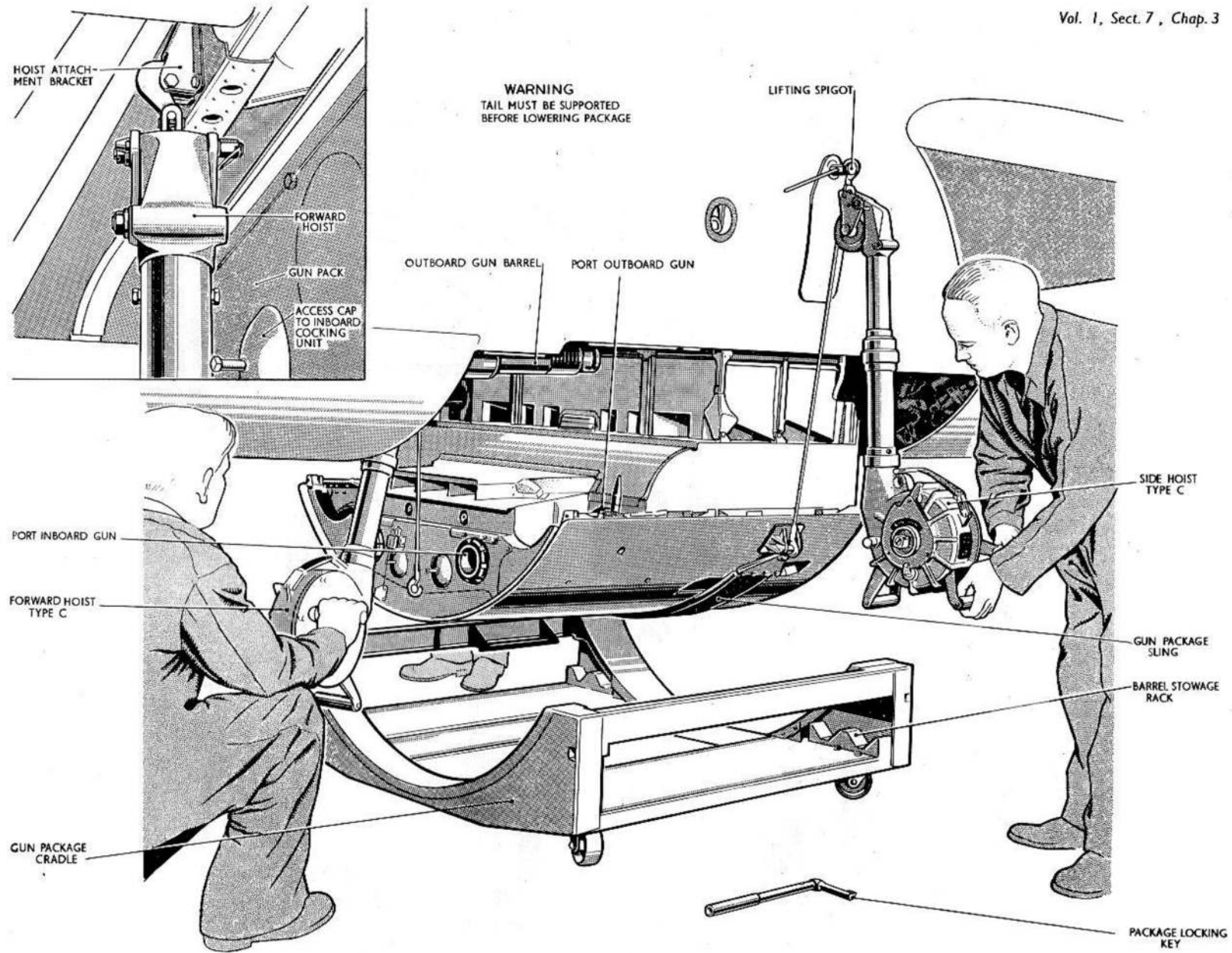
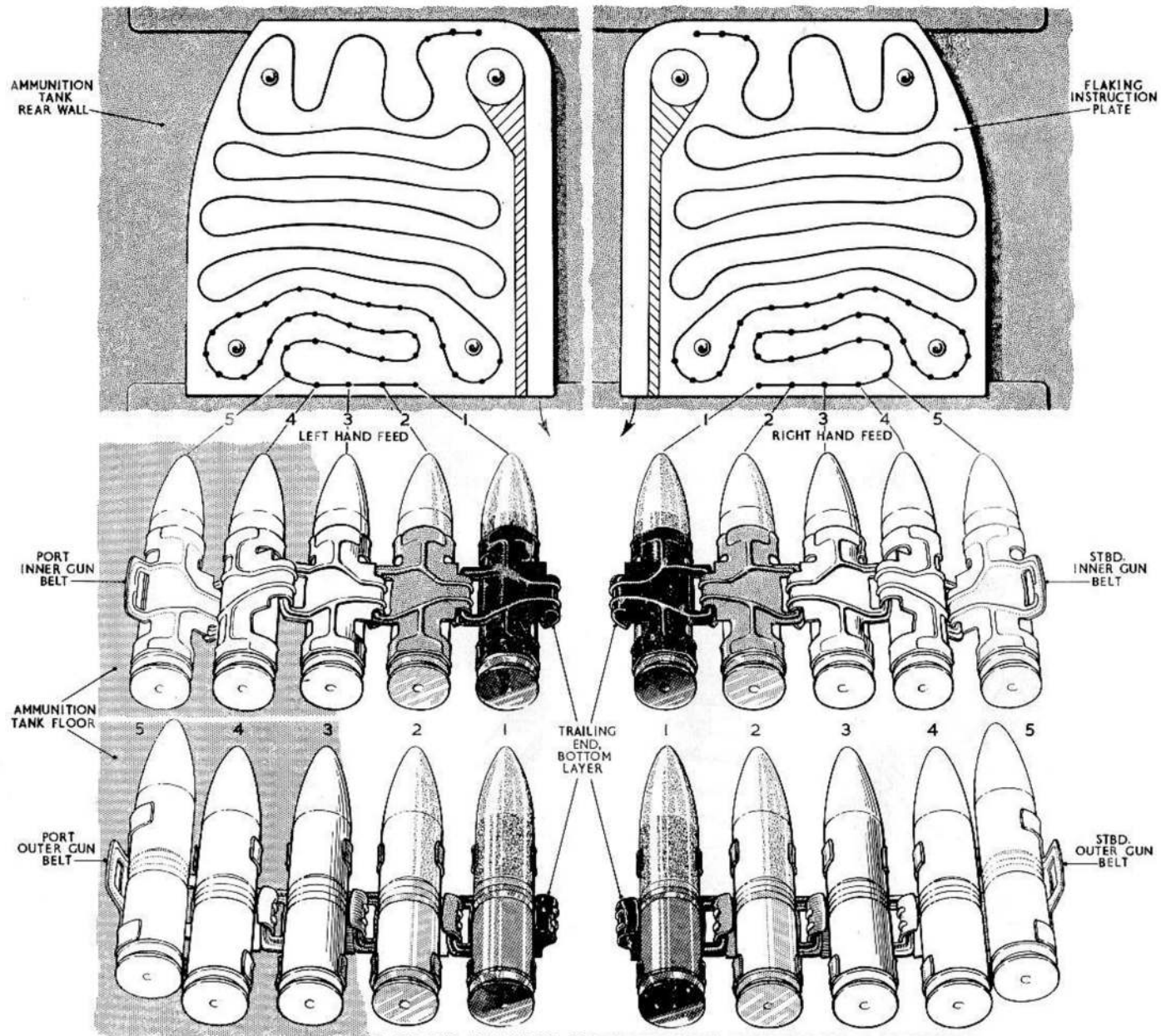

FIG. II PACKAGE REMOVAL (2)



THE FIRST FIVE ROUNDS FROM THE TRAILING END OF EACH BELT SHOWN ABOVE MUST BE LAID TO COINCIDE WITH THE LABEL ON THE AMMUNITION TANK FLOOR

FIG.12 AMMUNITION FLAKING

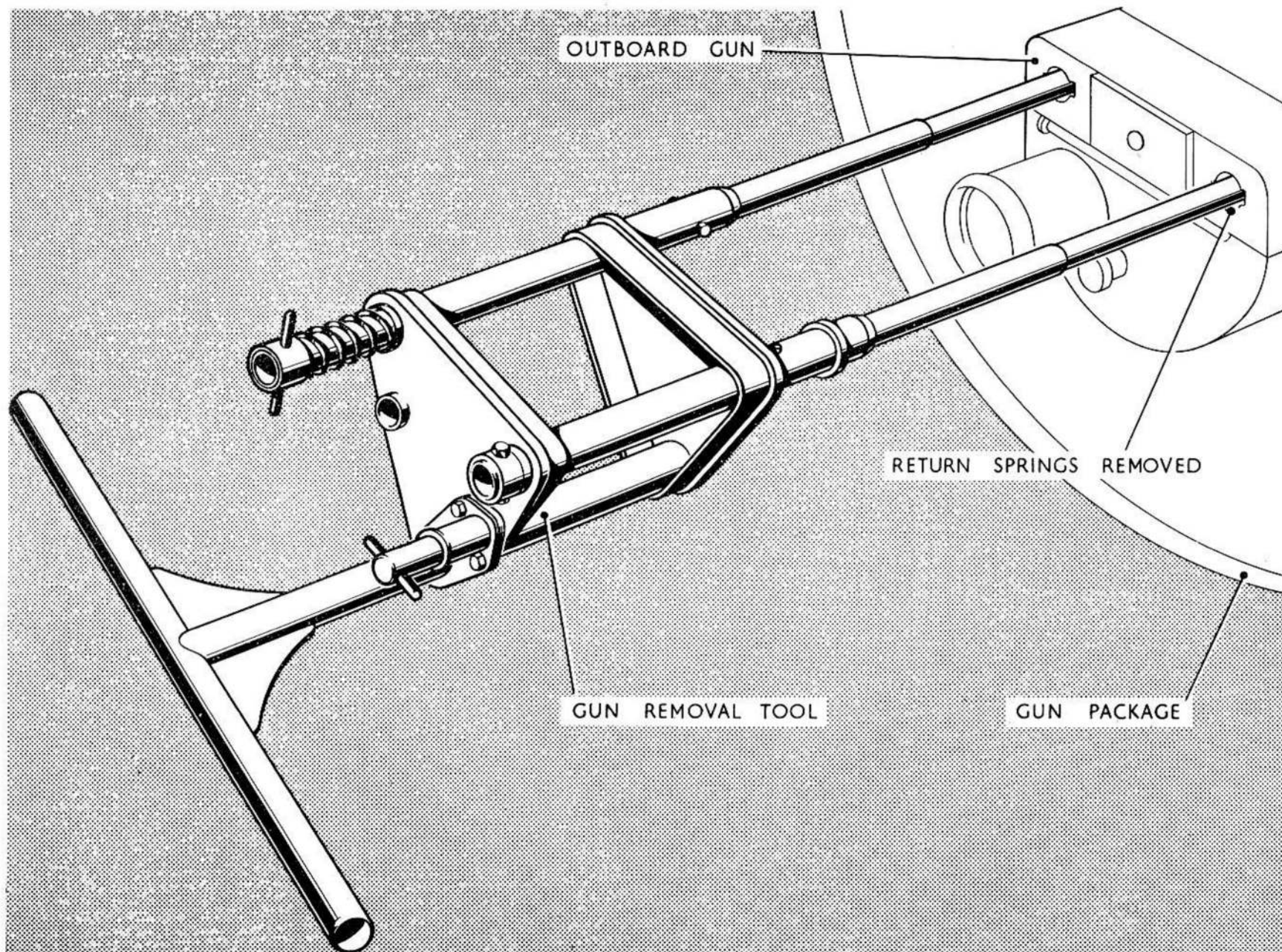

FIG. 13 GUN REMOVAL TOOL

This file was downloaded
from the RTFM Library.

Link: www.scottbouch.com/rtfm

Please see site for usage terms,
and more aircraft documents.

