

## CHAPTER 8

# FLY - IN REPAIRS

### **WARNING**

The information in this chapter is provided for the sole purpose of preparing an aircraft for a flight to a base or depot where the repair facilities necessary to restore the aircraft to a fully serviceable condition are available.

Temporary repairs and extended negligible damage quoted in this chapter **MUST NOT** be applied to aircraft required to perform normal flights.

The "fly-in" flight must take place in calm weather conditions and the aircraft must be flown in gentle manoeuvres only. The all-up weight of the aircraft and its maximum speeds in flight must not exceed those quoted in this chapter under the heading of **FLIGHT CONDITIONS**.

## CHAPTER 8 FLY-IN REPAIRS

### LIST OF CONTENTS

	Para.
Introduction	
Flight conditions ... ..	1
Operational equipment which can be removed ... ..	2
Minimum runway requirements ... ..	3
Strength concessions ... ..	4
Components to which no damage is acceptable ... ..	5
Extended negligible damage and temporary repairs ... ..	6

#### FRONT FUSELAGE

Permissible damage to :-	
skins ... ..	7
frames ... ..	8
longerons ... ..	9
keel members ... ..	10
windscreen and hood ... ..	11
nose cap ... ..	12
Temporary repairs to :-	
skin ... ..	13
frames ... ..	14
longerons ... ..	15

#### CENTRE FUSELAGE

Permissible damage to :-	
skin ... ..	16
nose spar frame ... ..	17
main spar frame ... ..	18
rear spar frame ... ..	19
frames ... ..	20
stringers ... ..	21
engine thrust members ... ..	22
tank skins ... ..	23

	Para.
spine ... ..	24
access doors ... ..	25
Temporary repairs to :-	
skin ... ..	26
frames ... ..	27
tank skins ... ..	28

#### STUB WING

Permissible damage to :-	
skin ... ..	29
air intake skins ... ..	30
diaphragms ... ..	31
Temporary repairs to :-	
skin ... ..	32
air intake skin ... ..	33
diaphragms ... ..	34

#### REAR FUSELAGE

Permissible damage to :-	
skin ... ..	35
frames ... ..	36
stringers ... ..	37
spine, dorsal fin, and structure under tailplane ... ..	38
tail cone ... ..	39
tank skins ... ..	40
Temporary repairs to :-	
skin ... ..	41
frames ... ..	42
stringers ... ..	43
tank skins ... ..	44

#### WINGS

Permissible damage to :-	
skin ... ..	45

	Para.
spars and undercarriage girder ... ..	46
nose rib A ... ..	47
nose ribs 1, 2 and 3 ... ..	48
nose rib G ... ..	49
nose rib G,1 ... ..	50
interspar rib G ... ..	51
interspar rib H ... ..	52
nose and interspar ribs ... ..	53
trailing edge ribs ... ..	54
stiffeners between trailing edge ribs ... ..	55
tank bay stringers ... ..	56
stringers outboard of rib G ... ..	57
tank support skins ... ..	58

#### Temporary repairs to :-

skin ... ..	59
spars and undercarriage girder ... ..	60
ribs ... ..	61
stringers ... ..	62
tank skins ... ..	63

#### AILERON

Permissible damage to aileron ... ..	64
--------------------------------------	----

#### TAILPLANE

Permissible damage to :-	
skin ... ..	65
spars ... ..	66
nose ribs ... ..	67
interspar ribs ... ..	68
structure aft of rear spar ... ..	69

Temporary repairs to tailplane ... ..	70
---------------------------------------	----

## FIN

	Para.
<i>Permissible damage to :-</i>	
<i>skin</i> ... ..	71
<i>spars</i> ... ..	72
<i>nose ribs</i> ... ..	73
<i>interspar ribs</i> ... ..	74
<i>structure aft of rear spar</i> ... ..	75
<i>Temporary repairs to fth.</i> ... ..	76

## ELEVATORS AND RUDDER

<i>Permissible damage to elevators</i>	
<i>rudder</i> ... ..	77

## LIST OF TABLES

	Table
<i>Performance data</i> ... ..	1
<i>Runway requirements</i> ... ..	2
<i>Strength concessions</i> ... ..	3
<i>Permissible damage to spars and</i>	
<i>undercarriage girder</i> ... ..	4

## LIST OF ILLUSTRATIONS

	Fig.
<i>Temporary repair to fuselage skin</i> ... ..	1
<i>Temporary repair to fuselage frames</i> ... ..	2
<i>Temporary repair to top longeron</i> ... ..	3
<i>Temporary repair to bottom longeron</i> ... ..	4
<i>Temporary repair to rear fuselage</i>	
<i>stringer</i> ... ..	5
<i>Temporary repair to wing skin</i> ... ..	6
<i>Temporary repair to stringer</i>	
<i>outboard of rib G</i> ... ..	7

## Introduction

When the information contained in this chapter is used to fly a damaged aeroplane consideration must be given to the repairs which will eventually have to be carried out to bring the aircraft to a fully serviceable state. This is particularly important when applying temporary repairs as the subsequent removal of the temporary repair may mean that a much larger permanent repair will have to be effected than would have been necessary if a permanent repair had been incorporated on the site before the aeroplane was flown in. This also applies when replacing damaged fixings, for example when replacing a rivet temporarily with a bolt, if the hole has to be opened up to accommodate the bolt and then opened up again to take a larger rivet at a later date the landing round the rivet hole may be reduced to an unacceptable amount. It is therefore advised that temporary fixings of the same size as the original fixings should be used as far as possible, and that consideration should be given to utilisation of the repairs given in Chapters 2 to 7 in preference to temporary repairs. Attention is also drawn to the value of fabric patches, where their use is permitted, as they do not involve any enlargement of the damage before a permanent repair is carried out.

## Flight conditions

1. The following flight conditions apply when flying a damaged aircraft back for repair :-

### (1) All-up weight

The maximum permissible all-up weight for the flight is 18,000 lb. whilst the minimum all-up weight, achieved by omitting the items listed in para.2, is 16,400 lb.

### (2) Speed, range, and height

The cruise speed, cruise height, and range for the "fly-in" flight which is to be made in calm weather conditions with gentle manoeuvres only may be found in table 1. The distances quoted are still air ranges using AVTUR fuel. For other than the special conditions listed below the limiting speed should be 300 knots A.S.I. which is 2.5 times the stalling speed (flaps up). The figures quoted in table 1 for the case without special conditions apply when the climb is made below 300 knots A.S.I. and 0.85 M with 90 gallons fuel reserve for descent and landing.

### (3) Special conditions

The following special conditions impose different restrictions on the fly-in flight to those quoted above. The cruise speed, cruise height, and range for each of these conditions may be found in table 1.

(a) Undercarriage locked down - Limiting speed 250 knots A.S.I. and 85 gallons fuel reserve for descent and landing.

(b) Flaps locked down at 45° - Limiting speed 250 knots A.S.I. and 80 gallons fuel reserve for descent and landing.

(c) Without fuselage nose cap - Limiting speed 250 knots A.S.I. and 85 gallons fuel reserve for descent and landing. Delicate equipment to be protected or removed.

(d) Without hood - Limiting speed 300 knots A.S.I. and 80 gallons fuel reserve for descent and landing. Provided that absence of hood is only damage, speeds up to 450 knots are permissible.

(e) Without cabin pressurisation - Limiting speed 300 knots A.S.I. and 90 gallons fuel reserve for descent and landing.

(f) Without power assistance on controls - Limiting speeds are 0.75 M. below 15 000 ft. and 0.85 M. above 15 000 ft. otherwise as for normal "fly-in" flight without special conditions.

These special conditions cause a loss in range due to the increase in aircraft drag. Where combinations of these special conditions occur an approximate guide to the range may be obtained by dividing the product of the ferry ranges for the conditions required by the sum of the ferry ranges for these conditions, giving the following formula :-

$$\text{Approximate range} = \frac{R1 \times R2}{R1 + R2}$$

where R1 and R2 are the ferry ranges of the special conditions of which a combination is required.

Operational equipment which can be removed

2. The aircraft may be flown solo and without all items of normal removable load. Compensating ballast need not be fitted for any of these items which reduce the A.U.W. to 16,400 lb.:-

- One pilot
- One parachute
- D.M.E. and controller (A.R.I.23013)
- One V.H.F. set
- Intercom.
- Modulator (A.R.I.18085)
- Gun and accessories
- Radar head, junction box, and ranging unit.
- Camera gun, mounting, and recorder
- Gunsights

- Clock
- One V.H.F. control
- One emergency oxygen set
- Spare starter cartridges
- De-icing fluid
- Harness apron
- Tail parachute

TABLE 1

Power plant	Avon 115 or 121
Fuel capacity (Imp.galls)	410
<b>Without special conditions</b>	
Ferry range (n.m.)	445
Cruise height (ft)	40 000
Cruise speed (knots A.S.L.)	260
<b>Undercarriage locked down</b>	
Ferry range (n.m.)	140
Cruise height (ft)	20 000
Cruise speed (knots A.S.L.)	250
<b>Flaps locked down at 45°</b>	
Ferry range (n.m.)	70
Cruise height (ft)	10 000
Cruise speed (knots A.S.I.)	150
<b>Without fuselage nose cap</b>	
Ferry range (n.m.)	170
Cruise height (ft)	20 000
Cruise speed (knots A.S.L.)	250
<b>Without hood</b>	
Ferry range (n.m.)	185
Cruise height (ft)	10 000
Cruise speed (knots A.S.I.)	300
<b>Without cabin pressurisation</b>	
Ferry range (n.m.)	365
Cruise height (ft)	35 000
Cruise speed (knots A.S.L.)	260

Minimum runway requirements

3. The minimum runway requirements for take-off and landing for all cases may be found in table 2. The actual take-off ground run for each case is approximately 65% of the distance to 50 ft. based on an unstick speed of 130 - 135 knots I.A.S. The figures given in table 2 are for I.S.A. conditions and should be corrected as follows :-

- (1) Height - Take-off distances increase by 12% for each 1,000 ft. above sea level.
- (2) Temperature - Take-off distances increase by 11% for each 10°C above 15°C.
- (3) Wind - Take-off distances are reduced by 5% for each 5 knots headwind.

TABLE 2

Take-off distance on runway to 50 ft. (yards)	1 400
Take-off distance on grass to 50 ft. (yards)	1 500
Landing distance from 50 ft. (yards)	1 400
Landing distance with parachute from 50 ft. (yards)	1 100
Landing distance with 45° flap from 50 ft. (yards)	1 800
Landing distance with 45° flap and parachute from 50 ft. (yards)	1 400

Strength concessions

4. All temporary repairs given in this chapter have been designed using light alloy to specification L.72 for parts which

do not require bending and steel to specification S.510 where bending is found to be necessary, thus avoiding the necessity for heat treatment. Light alloys to aircraft specifications other than L.72 and steels to aircraft specifications other than S.510 may be used in their place as they are equivalent to, or greater in strength than the materials originally specified. Where the correct gauge of material is not available thicker material may be utilised.

**Components to which no damage is acceptable**

5. The following components cannot be accorded relaxation and must be renewed if they are damaged beyond the limits given in the negligible and repairable damage

information contained in chapters 1 to 7 in Part 1 of this Vol.6 :-

- Engine mountings
- All flying control circuits
- All engine control circuits

**Extended negligible damage and temporary repairs**

6. The following paragraphs are intended as a guide to the Engineer Officer when assessing a damaged aircraft with a view to "flying-in" for repair. For convenience they have been divided into the basic components of the aeroplane, and it will be found that the wings are dealt with in more detail than the other components as they consist of heavier structure to carry

the heavier loads encountered. When assessing damage, attention is drawn to the fact that the more heavy the member the more load it is expected to carry and in consequence damage to these members should be considered very carefully. The use of Jo-bolts in place of rivets or bolts is permitted when carrying out temporary repairs detailed in these paragraphs.

**FRONT FUSELAGE**

**Permissible damage to skins**

7. Skins may be severely buckled, scored, or dented and holes up to 4.0 in. diameter or tears 4.0 in. in length may be permitted provided that no two items of damage are less than 8.0 in. apart and do not coincide with the attachment of internal structure (frames, longerons, etc.). Rivets may be damaged to the extent of five rivets in any group of ten provided that no more than two consecutive rivets are affected. All sharp edges should be dressed out and any cracks prevented from spreading by drilling holes at the extremities. All holes should be covered by a doped fabric patch or a suitable external metal patch which may be bolted or riveted into position. Loose rivets should be removed to ensure that they are not sucked into the air intake during the flight.

**Permissible damage to frames**

8. The frames are to be considered under the classifications "Light", "heavy", and "transport joint" as defined in Chap.2, para.9. Light frames, with the exception of 17A and 17B, may be severely bowed, buckled, or even completely fractured. Frames 17A and 17B may be bowed or buckled but must not be cut away by more than half of their original depth. Heavy

**TABLE 3**

Case	Condition	Fly-in repair standards		Normal flight standards	
		Strength	Weight	Strength	Weight
1.	Flight	Ultimate normal acceleration = 3.75	Maximum permissible A.U.W. - see Table 1.	Ultimate normal acceleration = 7.50	Maximum permissible A.U.W. - see Table 1
2.	Take-off	-	Maximum permissible T.O. Wt. - as above	-	Maximum permissible T.O. Wt. - as above
3.	Landing	Vertical velocity of descent not to exceed 9 ft./sec.	Maximum permissible landing Wt. - as above	Vertical velocity of descent not to exceed 13.50 ft./sec.	Maximum permissible landing Wt. = 16 250 lb.
4.	Gust	Maximum design gust speed 25 ft./sec.	-	Maximum design gust speed 50 ft./sec.	

frames with the exception of frame 8 may be damaged locally and may be cut away up to half of their original depth provided that the skin over the affected area of the frame is intact. Any damage to frame 8 or the transport joint frame 18A must be only of a minor nature.

**Permissible damage to longerons**

9. Damage of a minor nature only is permitted to longerons. Dents or local buckling is permissible and tears or holes up to 0.5 in. wide transversely and 3.0 in. in length may be allowed provided they are smoothly blended out and stopped from spreading. Very little damage should be allowed in the region of the transport joint frame 18A, and damage to the extruded booms should be confined to small nicks, scores and abrasions.

**Permissible damage to keel members**

10. Damage to the keel members and the box structure which supports the nosewheel must only be of a minor nature.

**Permissible damage to windscreen and hood**

11. The windscreen must be in a fit condition to protect the pilot from the airstream, but it is permissible to fly the aircraft without the hood being fitted. If the hood is to be used, the hood or attachments should not be damaged or repaired in such a manner that emergency jettison action can be affected.

**Permissible damage to nose cap**

12. Extensive damage is permissible to the nose cap. Provided that delicate equipment is protected or removed the aircraft may be flown without the nose cap.

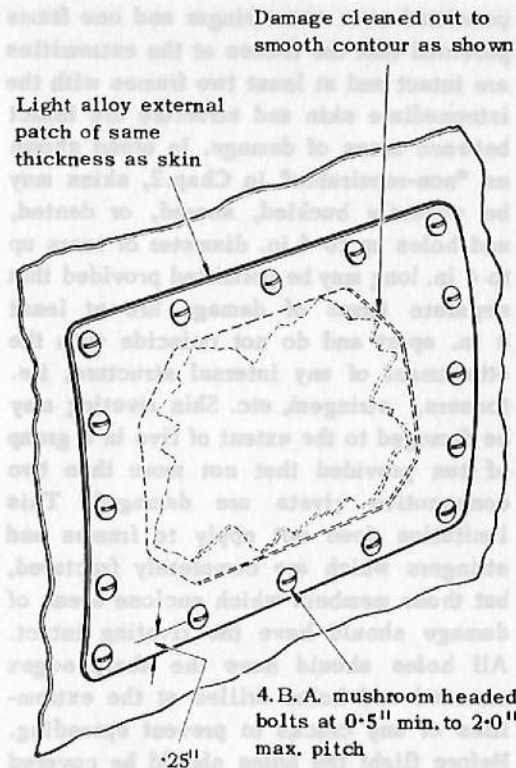

Fig.1. Temporary repair to fuselage skin

**Temporary repairs to skin**

13. Where damage to the skin is in excess of the limits defined in para.7 the skin should be dressed back to contour and the damaged cleaned out. An external patch of light alloy of the same thickness as the skin should then be fitted, held in position by a single row of 4 B.A. bolts all round the hole at a pitch of 0.5 in. minimum to 2.0 in. maximum as shown in fig.1. Where the skin is damaged in the region of a frame or longeron the bolted patch should also pick up with the frame or longeron. Where fixings have been damaged or lost in excess of that defined in para.7, they should be replaced. Bolts or pop rivets

may be used in place of solid rivets if desired.

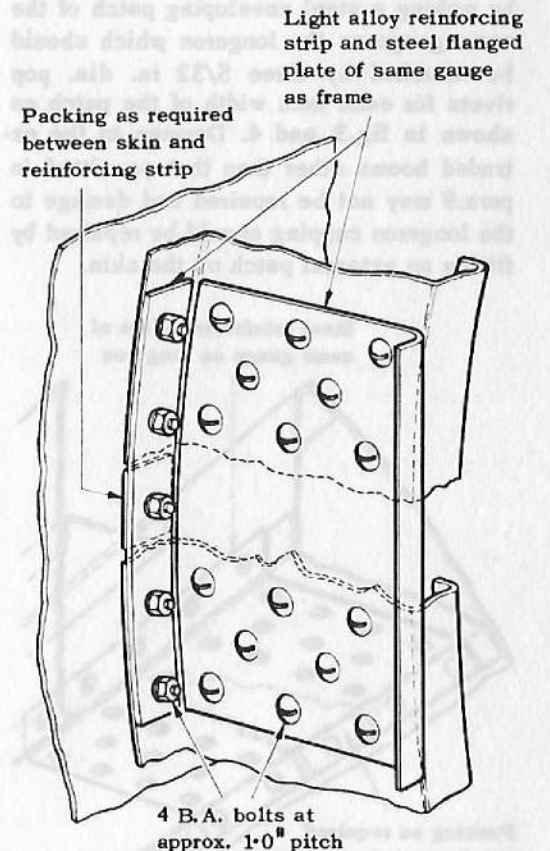

Fig.2 Temporary repair to fuselage frames.

**Temporary repairs to frames**

14. Frames damaged to an extent greater than that described in para.8 may be repaired by fitting a light alloy reinforcing strip on the inside of the skin attachment flange, and a flanged steel plate on the web of the frame, which should be attached by at least three rows of bolts or rivets on each side of the damage as shown in fig.2.

#### Temporary repairs to longerons

15. Damage to longerons other than that of a very minor nature should be repaired by making a steel enveloping patch of the same gauge as the longeron which should be attached by three 5/32 in. dia. pop rivets for each inch width of the patch as shown in fig.3 and 4. Damage to the extruded booms other than that permitted in para.9 may not be repaired and damage to the longeron capping should be repaired by fitting an external patch on the skin.

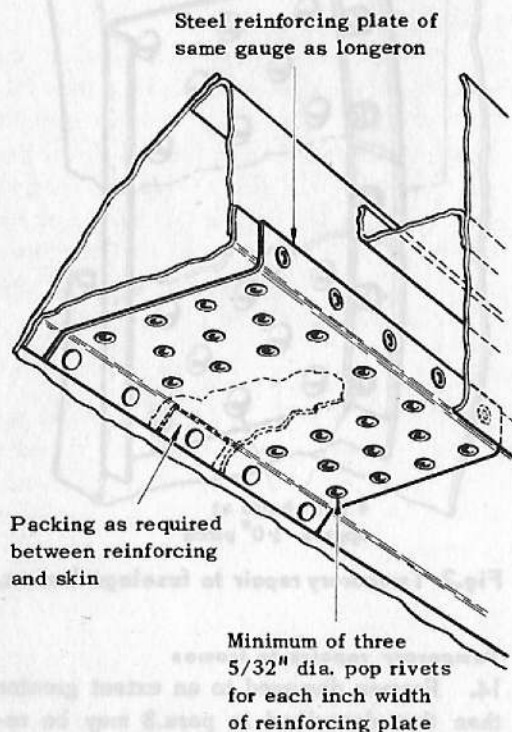

Fig.3. Temporary repair to top longeron

#### CENTRE FUSELAGE

##### Permissible damage to skin

16. Damage to the skin in the areas shown as "repairable" in Chap.2 may be

permitted over one stringer and one frame provided that the frames at the extremities are intact and at least two frames with the intermediate skin and structure are intact between areas of damage. In areas shown as "non-repairable" in Chap.2, skins may be severely buckled, scored, or dented, and holes up to 4 in. diameter or tears up to 4 in. long may be permitted provided that separate items of damage are at least 8 in. apart and do not coincide with the attachment of any internal structure, i.e. formers, stringers, etc. Skin riveting may be damaged to the extent of five in a group of ten provided that not more than two consecutive rivets are damaged. This limitation does not apply to frames and stringers which are completely fractured, but those members which enclose areas of damage should have the riveting intact. All holes should have the sharp edges removed and holes drilled at the extremities of any cracks to prevent spreading. Before flight the holes should be covered by a doped fabric patch or an external metal patch which may be bolted or riveted into position.

##### Permissible damage to nose spar frame (frame 19)

17. Damage to the part of the frame forming the stub wing spar may only be of a minor nature. Small dents or local buckles are permissible, and tears, holes, or cracks up to 1/2 in. wide transversely and 3 in. long may be permitted providing they are blended out and prevented from spreading. The portion of the frame in the fuselage proper may sustain more severe damage especially the lower portion which is liable to be damaged in a "wheels up" landing.

##### Permissible damage to main spar frame

18. Damage to the lower portion of the frame may be fairly extensive since there are two continuous booms across the frame connecting the wing attachment points which must remain undamaged. As the remainder of the frame acts as a bulkhead for the fuel tanks damage of a minor nature only is permitted.

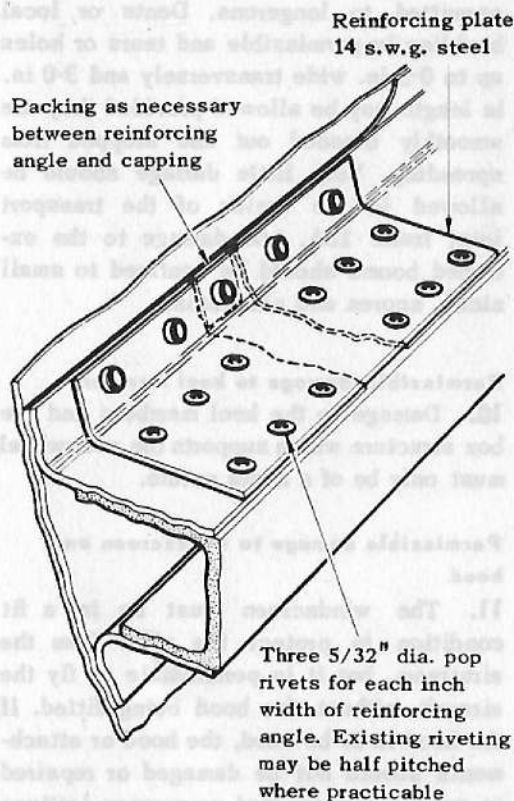

##### Note:

Damage to extruded boom must be only of a minor nature, and damage to the capping between longeron and skin should be repaired by a reinforcing plate on the outer skin surface.

Fig.4. Temporary repair to bottom longeron

**Permissible damage to rear spar frame**

19. The wing attachment fittings and their fixings must be intact and damage to the frame booms in these areas should only be of an extremely minor nature such as small nicks, scores, or abrasions. Elsewhere the booms may be damaged up to half of their cross-sectional area provided that the skin is not broken at the same point. Where the frame acts as a bulkhead for the fuel tanks damage is restricted to a minor nature only.

**Permissible damage to frames**

20. Damage to frame 33 which carries the aileron controls, to the frames carrying the engine loads (frames 34, 35, 38, and 40A) and to the rear transport joint (frame 40A) may be only of a minor nature such as curling of the frame flanges. Elsewhere frames may be damaged up to half of their section provided that they do not support a fuel tank, or that in the areas shown as "non-repairable" in Chap.2, the skin is not damaged in the same area.

**Permissible damage to stringers**

21. In the vicinity of the transport joints and spar frames damage to the stringers must be of a minor nature only. Elsewhere damage in "repairable" areas as shown in Chap.2, may be allowed up to complete fracture of three stringers on both port and starboard sides provided that there are two stringers undamaged (including the fixings) between any group of two or three broken ones and that at least two frames with the intermediate skin and structure are intact between areas of damage. Damage to stringer 'K' other than of a minor nature is not permitted. In areas shown as "non-repairable" in Chap.2, two stringers on

each side may be damaged up to complete fracture subject to the limitations shown for stringers in a "repairable" area, and provided that the damage does not extend across a frame or in a panel containing a stringer joint. This does not apply to stringer 'K' or stringers 'E' and 'H' between frames 21 and 32 where damage up to half the cross sectional area only is permitted.

**Permissible damage to engine thrust members**

22. No damage to the engine thrust members is permitted other than small dents or buckles, and the frames at the fore and aft ends must be reasonably intact.

**Permissible damage to tank skins**

23. Holes are not permitted in the tank skins, denting or slight buckling, however, may be permitted.

**Permissible damage to spine**

24. The spine is basically a fairing and any damage to the skin is permissible provided that the frames remain substantially complete and that the proper working of the flying controls is not endangered.

**Permissible damage to access doors**

25. Extensive damage to access doors is permissible provided that their attachments to the fuselage remain substantially intact. Holes in the skin should be covered by a doped fabric patch or a suitable external metal patch.

**Temporary repairs to skin**

26. Where the skin is damaged to an extent greater than permitted in para.16,

it should be repaired, after cleaning out the damage and stopping cracks, by fitting an external light alloy patch of the same gauge as the skin. This patch should be secured by a single row of 4 B.A. bolts all round and should pick up with any adjacent structure. In areas where access is not obtainable for fitting 4 B.A. bolts as shown in fig.1, two rows of 5/32 in. dia. pop rivets may be used. Excessively damaged skin riveting should be replaced, using pop rivets or bolts as required.

**Temporary repairs to frames**

27. Where frames are damaged to an extent greater than permitted in para.20, they may be repaired by fitting a light alloy reinforcing strip on the inside of the skin attachment flange, and a flanged steel plate on the web of the frame, which should be attached by at least three rows of bolts or rivets on each side of the damage as shown in fig.2.

**Temporary repairs to tank skins**

28. Holes in tank skins should be repaired by covering with a light alloy patch secured by one row of pop rivets all round. The edges of the patch should be chamfered to avoid chafing the tank.

**STUB WING**

**Permissible damage to skin**

29. Damage to the outer skins of the stub wing may take the form of holes up to 6 in. dia. provided they are clear of the leading edge and the boom of frame 19. Severe dents in the leading edges are permissible, provided that the riveting is reasonably intact. Cracks in the skin are permissible provided that they are prevented from spreading by drilling holes at

the extremities. All holes in the skin should be covered by a doped fabric patch or a suitable metal patch which may be riveted or bolted in position.

#### Permissible damage to air intake skins

30. Small dents, buckles, or pants are permitted in the air intake skin provided that the riveting is intact. Isolated rivets may be lost, and care must be taken to ensure that no loose rivets are left in these skins in case they are subsequently sucked into the engine.

#### Permissible damage to diaphragms

31. Both spanwise and fore and aft diaphragms may be damaged up to loss of half their depth provided that the contours of both air intake and outer skins are reasonably maintained.

#### Temporary repairs to skin

32. Excessive damage to the outer skin may be repaired by fitting an external light alloy patch of the same gauge as the skin. The patch should be secured by two rows of 5/32 in. dia. pop rivets all round and should pick up with any structure in the vicinity of the damage. Where pop rivet mandrel heads cannot be removed from the structure it is advised that the rivets should be dipped in Bostik before insertion.

#### Temporary repairs to air intake skins

33. Any holes in the air intake skins must be patched before flight. An external light alloy patch of the same gauge as the skin should be fitted using two rows of 1/8 in. dia. pop rivets all round to secure the patch, which should also pick up with any structure in the vicinity. Where the pop rivet mandrel heads cannot be removed from the structure it is advised that the rivets should be dipped in Bostik before insertion.

#### Temporary repairs to diaphragms

34. Excessive damage to the diaphragms should be repaired by fitting a steel channel of the same gauge as the diaphragm. This channel may be fitted on either side of the diaphragm and should pick up with both air intake and outer skins in addition to two rows of 5/32 in. dia. rivets on each side of the damage.

### REAR FUSELAGE

#### Permissible damage to skin

35. Damage found in the areas shown in Chap.2 as non-repairable may take the form of splits in the skin up to 12 in. in length, scores, abrasions, and dents, provided that the frames and stringers are not damaged beyond the limits given in para.36 and 37. Elsewhere on the rear fuselage proper the skin may be damaged over one frame provided that the frame at each end of the damaged area is intact, and over three stringers provided that the stringers above and below the damage are undamaged. At least two frames with the intermediate skin and structure should be intact, with sound riveting, between two areas of damage. Damaged skin riveting up to 6 in. long is permissible provided that there is 6 in. of sound riveting on each side of the damage. A series of small scattered holes may be permitted in any area of the skin. All holes in the skin must be covered before flight by a doped fabric patch or a suitable external metal patch which may be riveted or bolted in position.

#### Permissible damage to frames

36. Damage to frames in the areas shown as non-repairable in Chap.2, should be confined to minor buckles, nicks, and dents, except that below stringer 'K' the

frame flanges may be curled over, and frames 52 and 55 may be damaged up to complete fracture in this lower region. In areas not classed as non-repairable, in addition to minor buckles, nicks and dents, any frame may be damaged up to complete fracture provided that the frame on each side of it is intact, and provided that it does not support a fuel tank.

#### Permissible damage to stringers

37. Damage to stringers in the areas shown as non-repairable in Chap.2 should be confined to minor distortion, nicks, and dents. Elsewhere up to three adjacent stringers may be damaged up to complete fracture.

#### Permissible damage to spine, dorsal fin, and structure under tailplane

38. Damage to the spine, dorsal fin, and the skin and structure under the tailplane; with the exception of frames 52 and 55 and the tailplane actuator mounting, may be fairly extensive provided that the operation of the flying controls is not in any way impaired. Damage to the skin in the form of holes or splits should be covered by a doped fabric patch or a suitable external metal patch which may be riveted or bolted in position. No damage should be allowed to the tailplane actuator mounting and any damage to the upper portion of frames 52 and 55 should be of a very minor nature.

#### Permissible damage to tail cone

39. Extensive damage to the tail cone is permissible provided that the attachment to the fuselage is satisfactory and that the degree of distortion is not excessive.

#### Permissible damage to tank skins

40. On aircraft fitted with rear fuel tanks,

holes are not permitted in the tank skins; denting or slight buckling is, however, permissible.

**Temporary repairs to skin**

41. Where the skins are damaged to an extent greater than permitted in para.35, they should be repaired by fitting an external light alloy patch of the same thickness as the skin. The patch should be secured by a single row of 4 B.A. bolts all round, and should pick up with any structure which is in the vicinity of the repair. In areas where access is not obtainable for fitting 4 B.A. bolts as shown in fig.1 two rows of 5/32 in. dia. pop rivets may be used.

**Temporary repairs to frames**

42. Where frames are damaged to an extent greater than permitted in para.36 they may be repaired by fitting a light alloy reinforcing strip on the inside of the skin attachment flange, and a flanged steel plate on the web of the frame, which should be attached by at least three rows of bolts or rivets on each side of the damage as shown in fig.2.

**Temporary repairs to stringers**

43. Where stringers are damaged to an extent greater than permitted in para.37, they may be repaired by backing with a suitable angle of approximately the same section, as shown in fig.5.

**Temporary repairs to tank skins**

44. Holes in the tank skin should be covered with a light alloy patch secured by one row of pop rivets all round. The edge of the patch should be chamfered to avoid chafing the tank.

Joint to be made with light alloy or steel angle of similar cross sectional area to existing stringer

4 B.A. bolts at approx. 1.0" pitch

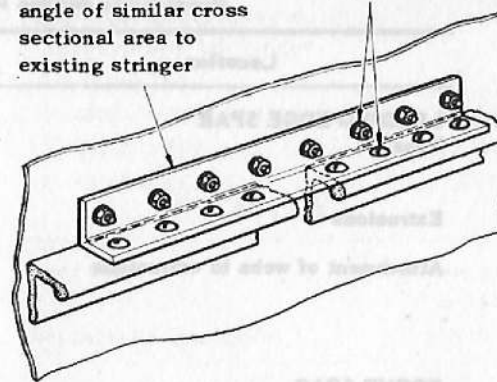

Fig.5. Temporary repair to rear fuselage stringer.

**WINGS**

**Permissible damage to skins**

45. Holes in the wing skin of up to 6 in. dia. are permitted provided there is 12 in. between centres of damage and not more than 1/3 of the skin from leading edge to rear spar is lost at any cross-section. Damage to the steel strap between skin and structure in the vicinity of the undercarriage pivot is confined to holes not greater than 15% of the width of the strap at the point concerned, with a maximum of 1.0 in. Damage to the skin riveting over the area covered by the steel strap is permitted as follows :-

Nose rib G	-	2 fixings in any group of 8
Nose rib G1 and interspar rib H	-	3 fixings in any group of 6
Interspar rib G	-	2 fixings in any group of 5
Front spar	-	2 fixings in any group of 4
Undercarriage girder	-	1 fixing in any group of 4

Elsewhere skin riveting may be damaged as follows :-

Leading edge spar	-	2 fixings in any group of 5
Nose rib A	-	2 fixings in any group of 6
Nose rib G	-	2 fixings in any group of 10
Elsewhere (including front spar, undercarriage girder and nose ribs 1, 2 and 3)	-	3 fixings in any group of 6

All holes in the wing skin must have the sharp edges removed, any cracks stopped, and be covered by a doped fabric patch or a suitable external metal patch which may be riveted or bolted in position.

**Permissible damage to spars and undercarriage girder**

46. Permissible damage to the leading edge spar, the front and rear spars, and the undercarriage girder may be found in table 4.

**Permissible damage to nose rib A**

47. Holes in the web are permitted up to half the depth of the web in diameter with a minimum distance equal to the local web depth between centres of any two holes. Loss of half the cross-sectional area of each boom is permitted but no damage to the spigot fitting or its attachments is allowed. Not more than two in any group of five of the web to boom attachments or more than two in any group of four of the attachments to the front spar may be lost.

**Permissible damage to nose ribs  
1, 2 and 3**

48. Holes in the webs up to 3 in. dia. are permitted with a minimum distance equal to the local web depth between centres of any two holes. They must however, be patched to support the tanks. A loss in area of the channels supporting the stringers is permitted up to 25% of the total cross-sectional area of both channels at one position. Attachments to the leading edge and front spar must be 75% effective.

**Permissible damage to nose rib G**

49. Holes in the web are permitted up to 40% of the web depth with a minimum distance equal to the local web depth between centres of any two holes. The web must be patched, however, to support the tanks. A loss in area of 0.2 sq.in. is permitted on each boom. Not more than two in any group of four web to boom attachments, or more than two in any group of eight of the attachments to the front spar may be lost.

**Permissible damage to nose rib G.1**

50. Holes up to half the web depth in diameter with a minimum distance equal to the local web depth between centres of any two holes are permissible. Not more than two in any group of four of the attachments to the front spar and rib G may be lost.

**Permissible damage to interspar rib G**

51. Holes in the web are permitted up to 25% of the web depth in diameter with a minimum distance equal to the local web depth between centres of any two holes. A loss in area of up to 0.2 sq.in. is permitted on each boom. Not more than two in any group of five of the web to boom attachments may be lost. Attachment to the front

**TABLE 4**

Permissible damage to spars and undercarriage girder

Location	Permissible damage
<b>LEADING EDGE SPAR</b>	
Webs	Holes up to 2 in. dia. with a minimum of 5 in. between centres.
Extrusions	Loss in cross-sectional area of 0.12 sq.in.
Attachment of webs to extrusions	1/4 in. bolts - not more than 2 in any group of 5 missing. 2 B.A. bolts - not more than 2 in any group of 8 missing.
<b>FRONT SPAR</b>	
<b>Booms</b>	
Around pins and 3 in. outbd.	Loss in area of 0.05 sq.in.
3 in. to 20 in. from pins.	Loss in area of 1.0 sq.in.
20 in. to 30 in. from pins.	Loss in area of 0.5 sq.in.
30 in. to 51 in. from pins.	Loss in area of 0.2 sq.in.
At joint between steel and light alloy booms.	Loss in area of 0.05 sq.in. on each boom provided damage does not run into holes of skin attachment flange.
57 in. to end of booms.	Loss in area of 0.2 sq.in.
Flanges of spar outbd. of light alloy booms.	Buckled flanges to be straightened. Flanges may be damaged up to the extent permitted by the limitations on skin riveting in para.45.
<b>Webs</b>	
7 in. to 21 in. from pins.	Two holes of 1.0 in. max. dia. with a minimum of 4 in. between centres.
21 in. to 48 in. from pins.	Holes up to 5 in. dia. with a minimum of 10 in. between centres. Rivets securing cover plates to be intact except where removed by a hole of permissible size.
48 in. to 57 in. from pins (to end of double web).	Holes up to 3 in. dia. with a minimum of 10 in. between centres.
57 in. to 73 in. from pins (to u/c pivot fitting).	Holes up to 1.5 in. dia. with a minimum of 10 in. between centres.
79 in. to 98 in. from pins (to end of booms).	Holes up to 4.5 in. dia. with a minimum of 10 in. between centres.
98 in. to tip.	Holes up to half of web depth with a minimum distance equal to the local web depth between centres.
<b>Web tie plate</b>	
	Two abrasions up to thickness of plate and 1.0 in. long which must be smoothed out. Vertical webs can be reduced to half their thickness. Attachment to web booms must be 2/3 effective.

TABLE 4 (continued)

Location	Permissible damage
<b>Webs (continued)</b>	
Attachment of webs to booms 0 in. to 57 in. from pins (to end of double web).	Must be 2/3 effective. Three consecutive lost bolts to be followed by 6 effective bolts.
57 in. to 100 in. from pins (to end of booms)	Must be 3/4 effective. Three consecutive lost bolts to be followed by 9 effective bolts.
Attachment of u/c pivot fitting to front spar.	Not more than one bolt to be lost.
<b>REAR SPAR</b>	
Web	Holes up to half of the web depth with a minimum distance equal to web depth between centres.
Flanges	Buckled flanges should be straightened. Damage is permitted up to the extent governed by the limitations on skin riveting in para. 45.
<b>UNDERCARRIAGE GIRDER</b>	
Wing attachment fittings.	Abrasions 0.05 in. deep across full width of fitting, which should be smoothed out.
Booms	Loss in area of 0.2 sq.in. at each boom at any position along their length.
<b>Webs</b>	
Inner end (double webs)	Abrasion up to 1.0 in. dia. and depth equal to thickness of one web. 80% of fixings in webs must be effective.
Outbd. of double webs to 20 in. from pins (to u/c jack anchorage bracket).	Holes up to 2.0 in. dia. with a minimum of 6.5 in. between centres.
20 in. to 45 in. from pins.	Holes up to 1.5 in. dia. with a minimum of 7.5 in. between centres.
45 in. to 57 in. from pins (to u/c pivot fitting)	Holes up to 2.0 in. dia. with a minimum of 8.5 in. between centres.
Attachment of webs to booms At wing attachment fittings.	All bolts must be sound.
Inbd. end (double webs).	Must be 7/8 effective. Isolated rivets missing only.
20 in. to 45 in. from pins.	Maximum of 2 rivets missing in any group of 6.
45 in. to 57 in. from pins.	Maximum of 2 fixings missing in any group of 5 (this includes 'Hi-shear' pins).

spar must be 50% effective while a minimum of five rivets is required attaching the rib to the rear spar.

**Permissible damage to interspar rib H**

52. Holes in the web up to half the web depth in diameter with a minimum distance equal to the local web depth between centres of any two holes are permitted. Attachments to the front spar must be 80% effective, and attachments to rib G 70% effective.

**Permissible damage to nose and interspar ribs**

53. Damage to nose and interspar ribs other than those mentioned in para.47 to 52 is permitted up to 50% of their strength.

**Permissible damage to trailing edge ribs**

54. No damage is permitted to the flap hinge ribs forward of the hinge and the attachment to the rear spar must be 70% effective. Elsewhere 50% of flanges and webs can be lost on each rib, and one rib may be completely cut through provided that there is an undamaged rib on each side. Two ribs may be completely cut through provided that there are two undamaged ribs between them.

**Permissible damage to stiffeners between trailing edge ribs**

55. Stiffeners may be damaged up to complete fracture provided that there is a sound stiffener on each side.

**Permissible damage to tank bay stringers**

56. A loss in cross-sectional area is permitted as follows :-

Upper stringers No.1 & 2 - 0.15 sq.in.  
Upper stringer No.3 and lower stringers - 0.10 sq.in.

**Permissible damage to stringers outboard of rib G**

57. A loss in cross-sectional area of 0.06 sq.in. is permitted. All bowed stringers must be straightened.

**Permissible damage to tank support skins**

58. All holes in the tank support skins must be patched to support the fuel tanks. Not more than two in any group of five of the rivets attaching the skins to the leading edge and front spars may be lost.

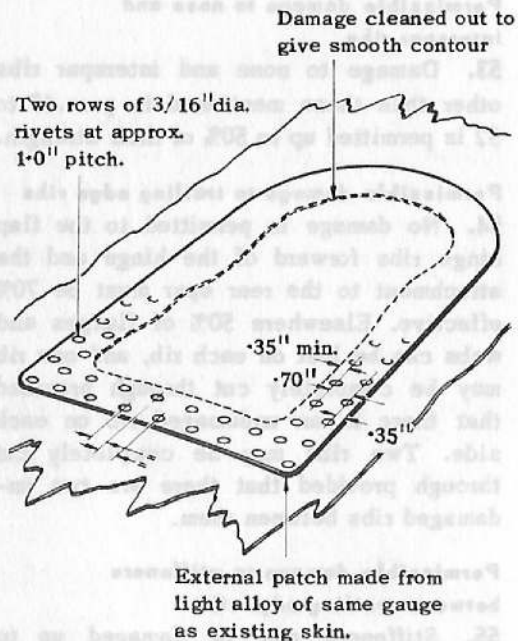

Fig.6. Temporary repair to wing skin.

**Temporary repairs to skin**

59. Where the skin is damaged to an extent greater than permitted in para.45 it may be repaired, after sharp corners have been removed and cracks prevented from spreading, by fitting an external light alloy patch with two rows of 3/16 in. dia. rivets or 2 B.A. bolts as shown in fig.6.

Where the damage occurs in the vicinity of internal structure the patch should pick up with the members concerned. Where an excessive number of skin fixings have been lost they should be replaced by rivets or bolts.

**Temporary repairs to spars and undercarriage girder**

60. Repairs should not be attempted to the booms of these members. Damage to the webs, except over the doubled portions, may be repaired by fitting a plate made from light alloy of the same gauge as the web, which should pick up with both top and bottom booms and should be joined to the sound part of the web on each side by two rows of 2 B.A. bolts at approximately 1.0 in. pitch staggered. Where the spar consists of a flanged plate member the repair plate should be flanged also and should pick up with the skin attachment rivets. Steel may be used where flanging is necessary.

**Temporary repairs to ribs**

61. Where ribs have extruded booms, repairs to the booms should not be attempted. Repairs to the webs of these members should take the form of a plate made from light alloy of the same gauge as the web, and should pick up with both top and bottom booms and two rows of 2 B.A. bolts on each side of the damage. Flanged plate ribs may be repaired by patching with a steel plate of the same gauge as the rib, with two rows of 5/32 in. dia. rivets all round the damage, picking up with the skin attachment rivets where necessary.

**Temporary repairs to stringers**

62. Stringers outboard of rib G may be repaired by backing with a 10 s.w.g. steel

angle picking up with three 2 B.A. bolts on each side of the damage as shown in fig.7.

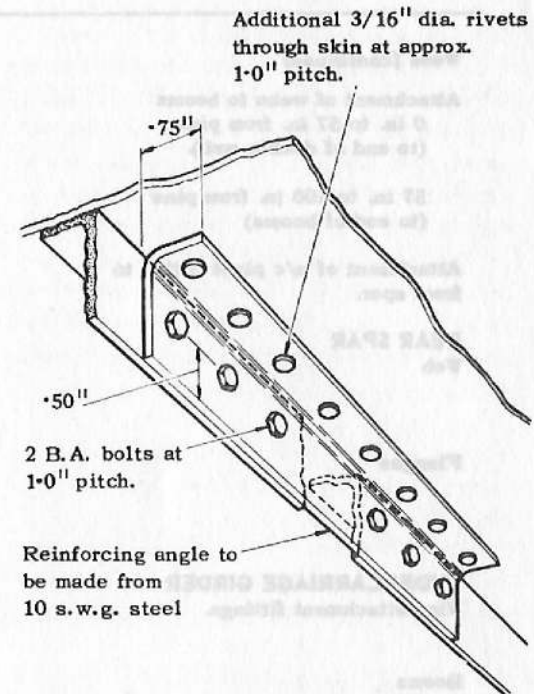

Fig. 7. Temporary repair to stringer outboard of rib G.

**Temporary repairs to tank skins**

63. Holes in tank skins should be repaired by covering with a light alloy patch secured by one row of pop rivets all round. The edges of the patch should be chamfered to avoid chafing the tank.

**AILERON**

**Permissible damage to aileron**

64. Small dents or buckles are permissible on the aileron skin and holes up to 4 in. dia. are permitted provided they do not occur in adjacent panels and are covered by a doped fabric patch before flight.

## TAILPLANE

### Permissible damage to skin

65. In areas shown as non-repairable in Chap.4 damage is confined to minor buckles, nicks, dents, or small scattered holes. Elsewhere extensive damage to the skin is permissible provided that the limitations on the damage to the structure are observed, that there is no marked degree of distortion of the component, and that the contour is reasonably maintained for patching. Bursts in riveted joints are permissible up to 6 in. long provided that there is 6 in. of sound riveting on each side of the damage. All holes in the skin should be covered by a doped fabric patch or a suitable metal patch which may be riveted or bolted in position.

### Permissible damage to spars

66. Minor damage only in the form of small nicks, dents, buckles, or holes is permitted on the spars.

### Permissible damage to nose ribs

67. Nose ribs may be damaged extensively provided that they are sufficiently intact to maintain the leading edge contour.

### Permissible damage to interspar ribs

68. Any rib, with the exception of those shown in non-repairable areas in Chap.4, may be damaged up to complete fracture provided that those on both sides are intact.

### Permissible damage to structure aft of rear spar

69. Damage to the ribs and elevator

shroud should not be extensive and it is essential to ensure that there is not any danger of the elevator movement being restricted.

### Temporary repairs to tailplane

70. As extensive damage has been permitted to the tailplane it is considered that it would be advisable to replace the tailplane with a serviceable unit should more extensive damage be encountered. Damage to skin riveting, however, may be brought to an acceptable state by the insertion of suitable rivets or bolts.

## FIN

### Permissible damage to skin

71. In areas shown as non-repairable in Chap.4, damage is confined to minor buckles, nicks, dents, or small scattered holes. Elsewhere extensive damage to the skin is permissible provided that the limitations imposed on damage to the structure are observed, that there is no marked degree of distortion of the component and that the contour is reasonably maintained for patching. Bursts in riveted joints up to 6 in. long are permitted provided that there is 6 in. of sound riveting on each side of the damage. All holes in the skin should be covered by a doped fabric patch or a suitable external metal patch which may be riveted or bolted in position.

### Permissible damage to spars

72. Only damage of a minor nature in the form of small nicks, dents, buckles, or holes, is permitted to the spars.

### Permissible damage to nose ribs

73. Extensive damage to the nose ribs is permissible provided that the leading edge contour is reasonably maintained for patching.

### Permissible damage to interspar ribs

74. Damage to interspar ribs is permitted up to complete failure provided that it does not occur in an area shown as non-repairable in Chap.4, and that ribs on both sides are intact.

### Permissible damage to structure aft of rear spar

75. Damage in this area should not be extensive, especially in the vicinity of the rudder hinges. It is essential to ensure that the rudder movement is not restricted, and that the proper working of the controls is ensured.

### Temporary repairs to fin

76. Should more extensive damage than outlined above be sustained, or the proper working of the controls be in doubt, it is considered advisable to change the fin for a serviceable component. Damage to the skin riveting, however, may be brought to an acceptable state by the insertion of appropriate rivets or bolts.

## ELEVATORS AND RUDDER

### Permissible damage to elevators and rudder

77. Small dents or buckles are permissible on the skin and holes up to 4 in. dia. are permitted provided they do not occur in adjacent panels and are covered by a doped fabric patch before flight.

This file was downloaded  
from the RTFM Library.

Link: [www.scottbouch.com/rtfm](http://www.scottbouch.com/rtfm)

Please see site for usage terms,  
and more aircraft documents.

