

**PART 1****DESCRIPTION AND MANAGEMENT  
OF SYSTEMS****LIST OF CHAPTERS**

- Chapter 1 — Fuel system**
- Chapter 2 — Engine controls and instruments**
- Chapter 3 — Electrical system**
- Chapter 4 — Hydraulic system**
- Chapter 5 — Powered flying controls and trimmers**
- Chapter 6 — Other aircraft controls and flight instruments**
- Chapter 7 — General equipment and controls**
- Chapter 8 — Aircrew equipment assembly and oxygen system**
- Chapter 9 — Radio and radar**
- Chapter 10 — Armament and camera installation**

## PART 1

## Chapter 1 — FUEL SYSTEM

## Contents

DESCRIPTION	Para.
Tanks ... ..	1
Fuel feed system — general ... ..	2
Booster pumps and fuel proportioner ... ..	3
Filter de-icing ... ..	4
<b>CONTROLS AND INDICATORS</b>	
LP fuel cock ... ..	5
Booster pump controls and indicators ... ..	6
Fuel contents gauges ... ..	7
Fuel transfer indicators ... ..	8
Fuel level indicators ... ..	9
Drop tank jettison controls ... ..	10
Pressure refuelling and defuelling controls ... ..	11
<b>NORMAL USE OF THE SYSTEM</b>	
Pre-flight checks of the system ... ..	12
Use of the system in flight ... ..	13
Unusable fuel ... ..	14
<b>MALFUNCTIONING OF THE SYSTEM</b>	
Booster pump failure ... ..	15
Transfer failure ... ..	16
Fuel gauge errors ... ..	17
Proportioner malfunction ... ..	18

## DESCRIPTION

**1 Tanks**

(a) Fuel is carried in six internal tanks, one in each wing and two front and two centre tanks in the fuselage. Each wing tank consists of four cells and is fitted in the forward edge of the wing. The fuselage tanks are of the flexible bag type.

(b) Provision is made for carrying either two or four tanks on underwing pylons.

(c) The tank capacities are:

<i>Tank</i>	<i>Gall.</i>	<i>AVTAG</i> 7.7 lb./gall.	<i>AVTUR</i> 8.0 lb./gall.
Front	202	1555	1616
Centre	72	554	576
Wing	140	1078	1120
<b>Total internal</b>	<b>414</b>	<b>3187</b>	<b>3312</b>
Add as appropriate:			
2 × 100 gall. drop tanks	200	1540	1600
4 × 100 gall. drop tanks	400	3080	3200

## 2 Fuel feed system — general

Fuel is fed to the engine by a booster pump in each front tank via a fuel proportioner and then through the LP and HP cocks. Fuel is transferred from the wing and centre tanks to the front tanks on the same side by air pressure from a tapping on the engine compressor. When drop tanks are carried fuel transfer is from the outer drop tank to the inner drop tank to the wing tank on the same side.

## 3 Booster pumps and fuel proportioner

(a) Each front tank contains an electrically-driven immersed booster pump fitted in a negative G fuel trap, the contents of which are used in inverted flight. The total contents of the traps are sufficient to provide for approximately 15 seconds inverted flight at full power at sea level.

(b) From the booster-pumps fuel passes to the fuel proportioner, which should ensure a balanced flow from both sides of the fuel system when both booster-pumps are working correctly.

(c) The proportioner consists of a matched pair of vane-type rotors, mounted on a common shaft. Two inlet ports, one for each rotor, accept fuel from the associated booster-pump. A single exit port passes the metered fuel through the LP cock to the engine.

(d) Should the proportioner rotors jam, fuel by-passes them via spring-loaded non-return valves. ▶

(e) Unequal feeding is only likely to occur if inlet pressures to the proportioner differ by more than 2 PSI; the greater the pressure difference, the greater the amount of unequal feeding.

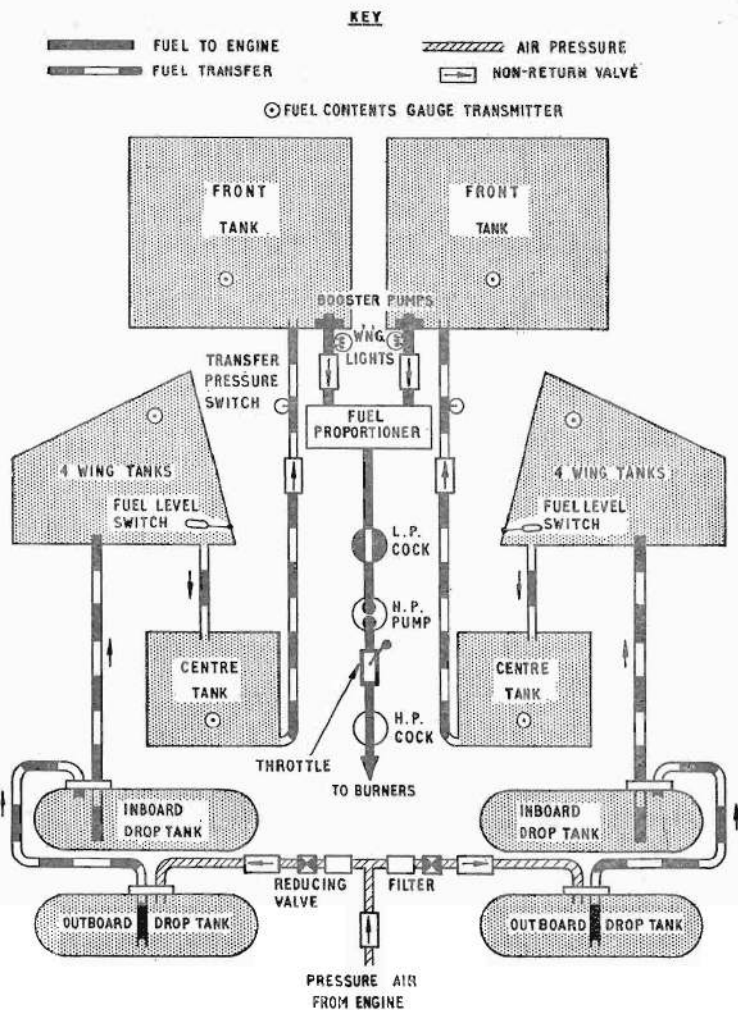

**FUEL SYSTEM DIAGRAM**

#### **4 Filter de-icing**

(a) Since fuel contains a small amount of water an automatic de-icing system is fitted to ensure that the fuel filter is not blocked by ice crystals at low OAT's. When icing occurs an electric pump is switched on and pumps alcohol to the filter. It is brought into use by the increasing pressure drop through the filter. When the pressure drop returns to normal, the system is switched off.

(b) The de-icing fluid tank, of one gallon capacity, is in the engine bay.

### **CONTROLS AND INDICATORS**

#### **5 LP fuel cock**

The LP fuel cock control is on the port shelf and is moved forward from OFF to ON. It controls the fuel flow to the engine via the HP cock.

#### **6 Booster pump controls and indicators**

(a) Each booster pump is controlled by an ON/OFF switch on the centre panel; a circuit breaker for each pump is on the coaming above the centre panel. The engine master switch must be ON to complete the electrical circuit to the booster pumps.

(b) Adjacent to the switches are two amber warning lights, one for each pump, which come on if the associated booster pump fails or is switched off.

(c) A red warning light above the pump warning lights comes on if fuel delivery pressure from the booster pumps falls to approximately 3.5 PSI.

(d) A test switch and an ammeter socket are provided, for servicing purposes, on the starboard shelf.

#### **7 Fuel contents gauges**

(a) Two electrical fuel contents gauges at the top of the centre panel indicate the total fuel in the PORT and STBD tanks (front, wing, and centre). The contents of the 100-gallon drop tanks are not gauged.

(b) The fuel gauges read the weight of fuel in pounds. When all gauged tanks are full (front, wing, centre) each gauge should read 1500 lb. approx. when transfer pressure is available.

(c) A fuel contents check switch, on the coaming above the centre panel, is labelled ENGINE ON/ENGINE OFF and is spring-loaded to the ENGINE ON position. By selecting and holding ENGINE OFF, the total fuel contents can be checked with the engine shut down on the ground, or in conditions of transfer pressure failure in the air.

## 8 Fuel transfer indicators

All internal fuel is gauged, and the contents reading should fall when fuel is being used from these tanks. When transfer from the 100-gallon drop tanks (which are un-gauged) is taking place the fuel contents gauges should show a constant reading. Should the air pressure fail, no fuel transfers from the drop, wing or centre tanks and the TRANS. FAILURE indicators on the centre panel indicate failure by showing white. At the same time the contents gauge transmitters in the centre and wing tanks become inoperative and the gauges should only indicate the contents of the front tanks, i.e., the amount of fuel available to the engine. If only one side of the air pressure system fails, the appropriate indicator shows white and the associated gauge indicates the available fuel contents.

## 9 Fuel level indicators

Two magnetic indicators, one for each outboard tank, are below the contents gauges. Each shows white when all fuel has transferred from its associated outboard drop tank.

## 10 Drop tank jettison controls

(a) The inboard drop tanks may be jettisoned by pressing the INBD STORES jettison pushbutton, on the armament control panel beneath the port glare shield, provided the bomb fuzing switch is at OFF.

(b) Outboard drop tanks may be jettisoned by pressing the OUTBD STORES pushbutton, on the armament control panel.

(c) All four drop tanks may be simultaneously jettisoned by pressing down the CLEAR A/C switch bar, above the pushbuttons. The bomb fuzing switch must be at OFF to allow the inboard drop tanks to jettison.

## 11 Pressure refuelling and defuelling controls

(a) Refuelling is via a connection in the port wheel bay. As each set of tanks is filled, refuelling valves automatically cut off the fuel being supplied to them. During refuelling the LP cock must be OFF, and the defuelling cock OFF. The battery master switch (or an external DC supply) and a time switch adjacent to the coupling must be ON in order to energise the refuelling circuit. Aircraft which embody the relevant Command modification, however, may be refuelled with the battery master switch at OFF and without external power.

(b) Defuelling is via the same coupling. Before defuelling, the defuelling cock, accessible via the engine starter access door, must be selected ON and the LP cock must be selected OFF. An air pressure of 10 PSI is necessary to transfer fuel to the front tanks whence it is either sucked out by the bowser pump or pumped out by the booster-pumps. The air pressure connection is on top of the centre fuselage.

## NORMAL USE OF THE SYSTEM

### 12 Pre-flight checks of the system

(a) The HP and LP cocks must be ON and the booster pumps should normally be ON at all times when the engine is running.

(b) Before starting, check that the booster pump circuit breakers are made.

(c) After starting, test the booster pump warning lights by switching both booster pumps OFF and then ON again.

### 13 Use of the system in flight

(a) Correct functioning of the system is shown by the fuel contents gauges indicating equal fuel levels, the LP warning light out and the indicators reading as follows:

- (i) Booster pump warning lights -- Out
- (ii) Transfer indicators -- Black
- (iii) The two outboard drop tank magnetic indicators show white when the *outboard* drop tanks are empty or not fitted.

(b) The proportioner maintains accurate fuel balancing with both booster-pumps on or off, provided that the

pressures at which the fuel enters the proportioner from the booster-pumps do not differ by more than 2 PSI. If unequal emptying occurs with all indicators normal, either the proportioner has failed or the inlet differential pressures are greater than 2 PSI in which case fuel balancing must be controlled manually by switching off the pump on the "low" side until the levels become equal and then switching it on again.

#### 14 Unusable fuel

At low fuel states, i.e., below 200 lb/side, excessive attitudes or accelerations may cause fuel in the tanks to move away from the booster pumps, resulting in fuel starvation and possible flame extinction.

### MALFUNCTIONING OF THE SYSTEM

#### 15 Booster-pump failure

(a) If a booster pump fails, indicated by its warning light coming on, and the corresponding contents gauge reading high by comparison with the other if the drop tanks are empty, no fuel will be used from that side if the serviceable pump is left ON.

(b) (i) Immediately, check the booster pumps circuit breakers and, if failure is confirmed, reduce to idling RPM, switch OFF the failed pump(s), and descend to a height of:

25,000 ft. — clean or with empty drop tanks

20,000 ft. — with 2 or 4 drop tanks containing fuel.

If maximum range is vital, these heights may be increased by a maximum of 10,000 ft., accepting the risk of possible damage to the HP fuel system.

(ii) Then, switch OFF both booster pumps and accept the fuel feed provided by tank pressurisation and gravity. RPM thereafter must not exceed 7,200.

(c) With both booster-pumps off, negative G manoeuvres must not be carried out. It is important to land while both sides still contain fuel, because the flow proportioner maintains out-of-balance levels and the engine will not run with one side empty unless the booster-pump in the side containing fuel is running. The serviceable pump should be switched on for a landing if a sufficient head of

fuel remains on that side, but it should be remembered that with the pump on, fuel is only used from that side.

(d) The engine must subsequently be examined for damage to the HP fuel system.

## **16 Transfer failure**

If one or both transfer indicators shows white, transfer pressure failure has occurred and steep dives should be avoided due to the possibility of collapsing the tanks. Should an indicator show white before fuel transfer is complete, any fuel remaining in the centre and wing tanks is unusable and the associated contents gauge only indicates the usable fuel in the front tanks (800 lb. maximum per tank). In these circumstances if the gauge registers more than the total contents of a front tank a faulty gauge should be suspected and only the front tank fuel should be relied on as being available to the engine. If air transfer fails on one side, the booster-pump on the side with transfer failure should be switched OFF until the contents gauge of the other side indicates an equal amount; then reset the pump ON.

## **17 Fuel gauge errors**

The fuel contents gauges have been found to give erroneous indications due to temperature effects on the electrical gauging system. The magnitude of the error depends on both temperature and time. Low temperatures at high altitude give gauge under-reading; high temperatures, high speeds at low altitude give gauge over-reading. During a descent from altitude, if the assessed inaccuracy was a gauge under-reading, the gauges progressively become more accurate and may eventually tend to over-read.

## **18 Proportioner malfunction**

⚡ A malfunctioning proportioner can cause unbalanced fuel flow. A return to base should be made as soon as possible. An attempt may be made to correct any fuel imbalance by selective switching of the booster-pumps. ▶

## PART 1

## Chapter 2 — ENGINE CONTROLS AND INSTRUMENTS

### Contents

DESCRIPTION	Para.
Avon 122 engine ... ..	1
Variable incidence guide vanes and air bleed valves ...	2
Starting system ... ..	3
Engine fire-extinguisher ... ..	4
<b>CONTROLS AND INDICATORS</b>	
HP fuel cock ... ..	5
Throttle controls ... ..	6
Starting controls ... ..	7
Relighting control ... ..	8
HP pump isolating valve and warning light ... ..	9
Top temperature control ... ..	10
Engine instruments ... ..	11
Engine fuel and air dipping system ... ..	12
Engine anti-icing ... ..	13
Management of the engine anti-icing system ... ..	14

### DESCRIPTION

#### 1 Avon 122 engine

##### (a) General

The engine is a 12-stage axial-flow gas turbine. The Avon 122 develops 7,575 lb. static thrust at sea level. The main engine systems include:

Variable incidence guide vanes (see para. 2).

A cartridge starting system (see para. 3).

Relighting facilities (see para. 8).

An anti-icing system (see para. 13).

A high-pressure fuel system controlled by a flow control unit.

A self-contained oil system.

*(b) High-pressure fuel pumps*

The twin engine-driven HP pumps share a common housing. A servo-control system controls the total pump output and a governor prevents over-speeding of the engine.

*(c) Flow control unit*

The servo-control system is operated by the barometric pressure control (BPC) and acceleration control unit (ACU), and varies fuel flow to the engine according to throttle position, altitude, forward speed and RPM.

*(d) Oil system*

Oil is carried in the engine sump, the capacity of which is 17 pints. One pressure and two scavenge pumps maintain a continuous circulation through a cooler and filter to the engine bearings and gears.

## **2 Variable incidence guide vanes and air bleed valves**

*(a)* The first row of stator blades in the engine consists of variable incidence guide vanes which impart swirl to the incoming air. At low RPM the first stages of the compressor deliver more air than is acceptable to the later stages. To prevent surge, the surplus air is bled off from stages 4 to 7 through air bleed valves and the guide vanes are held in the maximum swirl position. The air bleed valves are controlled by compressor delivery air pressure and the swirl vanes ram by HP pump delivery fuel pressure.

*(b)* The guide vanes start to move from the maximum swirl position at about 6,400 RPM and reach the minimum swirl position at about 7,550 RPM. The bleed valves close at about 6,500 RPM.

*(c)* The guide vanes and bleed valve positions have no noticeable effect on RPM, but until the guide vanes are in the minimum swirl position and the bleed valve is closed the engine is not operating at maximum efficiency: thrust is reduced and fuel consumption is increased.

## **3 Starting system**

*(a)* Starting is by means of a triple-breech cartridge starter system, which accelerates the engine until it becomes self sustaining.

(b) When the starting cycle is initiated, a cartridge is indexed and fired and burns for about 3 seconds to turn the engine compressor. At the same time the engine high energy igniter units operate to ignite the fuel spray in the engine combustion chambers. After approximately 30 seconds the engine becomes self sustaining and a switch operates to shut down the starting system and release the starter button, which has been held in during this time.

#### 4 Engine fire-extinguisher

(a) A fire-extinguisher bottle, stowed between the air intakes just forward of the engine, is connected to two spray rings in the engine bay. Operation of the system is either by:

(i) A manually-operated pushbutton in the cockpit on the centre panel, or

(ii) Automatically-operated inertia switches in the radio bay, which operate if a crash landing occurs. Operation of the switches also cause the batteries to be isolated irrespective of the position of the battery master switch. (Chap. 3, para. 4).

(b) Fire detection is provided by a Triple-FD firewire system. Two firewire detector loops surround the engine and forward part of the jet pipe. If the temperature in the engine bay exceeds a pre-determined level the loops complete a circuit to the ENGINE FIRE warning light in the pushbutton. When the button is pressed the extinguisher discharges its contents through the spray rings, one round the engine compressor and the other round the turbine nozzle box. If the fire is extinguished, the light goes out as the firewire cools.

(c) The firewire circuit may be tested by using the test button which is adjacent to the fire warning light. If the circuit is serviceable the light appears. Unserviceability of the system is indicated either by the warning light not illuminating or failing to extinguish when the test button is released. Testing should be done before engine start and immediately after flight, when optimum conditions for moisture contamination of the firewire have been experienced. Testing of the Triple-FD system should not normally be done in the air.

(d) Pre Mod. 1024, fire detection is achieved by twelve resetting flame detector switches around the engine and forward part of the jet pipe. Operation of any of the switches causes the ENGINE FIRE warning light to come on. Only the warning light is tested when the test switch is operated.

(e) When the battery master switch is OFF the fire extinguisher can be operated only by the inertia switches. The battery master switch must be ON to test the warning circuit or to operate the system by pushbutton.

## CONTROLS AND INDICATORS

### 5 HP fuel cock

The HP fuel cock control is in a quadrant on the cockpit port shelf, and is moved forward from OFF to ON. A safety gate is provided to ensure that the HP cock cannot be moved unless it is first pressed downwards.

### 6 Throttle controls

Two throttle control levers are provided, one in a quadrant on the port shelf, and the other on the centre pedestal; the throttles are interconnected. The handle of each lever incorporates a twist-grip for GGS manual ranging, a press-to-transmit switch and an airbrake control. A throttle damper is provided aft of the lever on the port shelf.

### 7 Starting controls

The main control switches below the port instrument panel are:

(a) *The battery master switch*

(b) *The ignition switch* which controls the current to the igniter plugs. It should normally be locked in the ON position.

(c) *The engine master switch and circuit breaker (centre pedestal)* which complete the circuit through the starter button, ignition switch and relight button in its normal out position. The engine master switch also controls the electrical supply to the engine instruments, and completes the circuits to the standby inverters and the booster-pumps. The switch should be ON and the circuit breaker closed at all times when the engine is running.

(d) *The starter pushbutton* which initiates the starting sequence.

NOTE: The engine starting procedure is covered in Part 3, Chapter 1.

## 8 Relighting control

A relight button is in the top of the HP cock control lever and when held in completes the circuit to the high energy ignition units. The button is spring-loaded to return to the out position.

NOTE: The relighting procedure is covered in Part 4, Chapter 1.

## 9 HP pump isolating valve and warning light

(a) The isolating valve is intended as a means of restoring power in flight in the event of failure of the HP pumps servo system causing a sudden loss of power.

(b) The valve is controlled by an ENGINE FUEL PUMPS—NORMAL/ISOLATED switch on the port shelf. When the switch is set to ISOLATED, one HP pump is cut off from the servo system which continues to control only the other HP pump. The isolated pump moves to full stroke and is controlled only by its over-speed governor.

(c) An adjacent warning light indicates when the isolating switch is on.

## 10 Top temperature control

(a) A top temperature control system prevents the jet pipe temperature from rising above the permissible maximum (690°C) by partially closing the throttle when this temperature is reached. Further throttle opening is restricted until the jet pipe temperature drops below this maximum. When the temperature drops, the throttle is automatically returned to its original setting and its full range of movement is restored. The system requires both AC and DC supplies; AC is supplied by No. 1 group inverters immediately the AC supplies circuit is operating. The DC supply is controlled by a JET PIPE TEMPERATURE CONTROLLER — ON/OFF switch on the port shelf, which should normally be selected ON, and an override

microswitch operated by the closing of the nosewheel door.

(b) When the nosewheel door is up and locked, the microswitch closes and starts a time switch; after approximately 30 seconds the time switch operates to allow DC to the ON/OFF switch. Provided that ON is selected, the top temperature control system is operative.

(c) Malfunctioning of the system is indicated by a JPT reading above 690°C or by a sudden drop in RPM of up to 1,000. In either case the switch should be set to OFF and the JPT and RPM controlled by throttle movement.

## **11 Engine instruments**

The engine instruments comprise a jet pipe temperature gauge, an oil pressure gauge and an RPM indicator. The JPT gauge and RPM indicator are on the port instrument panel; the oil pressure gauge is below the port instrument panel.

## **12 Engine fuel and air dipping system**

(a) An engine fuel and air dipping system automatically decreases RPM to minimise the risk of surge during gun-firing.

(b) When either gun-firing trigger is pressed, solenoid-operated fuel and air dip valves operate to restrict fuel flow to the engine and to bleed air from the compressor, thus causing a drop in RPM.

(c) The amount of fuel bled in a given time is constant and independent of throttle position. At part throttle settings this can result in RPM dropping below flight idling; throttle response is then uncertain, particularly at low altitude and low airspeed. RPM drop is further aggravated if the gun-firing trigger is held for lengthy periods; for this reason it is important that the camera button and not the gun-firing trigger is used during cine gun practice.

(d) If the RPM should drop below flight idling, they may be restored, provided that the engine is not in a surge condition, by setting the HP pump isolating switch to ISOLATED (para. 9).

NOTE: If the throttle is opened when firing in buffet conditions, the throttle opening time must not be less than 2 seconds.

### 13 Engine anti-icing

An engine anti-icing OPEN/SHUT switch and indicator are forward on the centre pedestal. The indicator shows red when open and green when shut. Hot air is tapped from the engine compressor and with the switch OPEN is ducted to the inlet guide vanes. The system is *not* intended for de-icing, but to prevent ice forming.

### 14 Management of the engine anti-icing system

(a) With the system in use, all throttle movements must be made smoothly. There is a loss of thrust (about 7%), increased fuel consumption and IPT usually rises about 20°C. At full throttle, RPM may then fall if the top temperature control comes into operation.

#### (b) *Ground running*

In conditions of fog or mist at OAT's below +5°C switch OPEN anti-icing immediately after starting. Taxi and, if runway length permits, take-off with the system OPEN: otherwise run the engine at about 7,000 RPM for one minute immediately before take-off and then switch the system SHUT. Switch the system OPEN again as soon as possible after take-off and leave it OPEN until 2 minutes clear of icing conditions.

NOTE: Do not carry out any engine acceleration checks with the system on.

#### (c) *Level flight*

If icing conditions are met in level flight, climb or descend out of the icing level (see (d) and (e) below).

#### (d) *Climbing*

Open up to not less than 7,200 RPM and set the anti-icing switch to OPEN. Climb at the maximum practicable rate.

#### (e) *Descending*

Throttle back to not less than 5,500 RPM and set the switch to OPEN. Descend at the maximum practicable rate; maximum anti-icing protection is obtained at the highest practicable RPM.

(f) When clear of icing conditions, set the switch to SHUT and wait for about 10 seconds before making any rapid throttle movement. If icing conditions persist down to airfield level keep the switch at OPEN and maintain engine speed above 5,500 RPM until finally committed to a landing.

## PART 1

## Chapter 3 — ELECTRICAL SYSTEM

## Contents

DESCRIPTION	Para.
DC supplies ... .. .	1
Standby DC supplies ... .. .	2
AC supplies ... .. .	3
Inertia switches ... .. .	4
<b>CONTROLS AND INDICATORS</b>	
Generator controls and indicators ... .. .	5
Main battery control ... .. .	6
Standby battery controls ... .. .	7
AC supply — controls and indicators ... .. .	8
Warning indicators ... .. .	9
<b>NORMAL USE OF THE SYSTEM</b>	
Pre-flight procedures ... .. .	10
<b>MALFUNCTIONING OF THE SYSTEM</b>	
Inverter failure ... .. .	11
Single generator failure ... .. .	12
Double generator failure ... .. .	13
Double generator and battery failure ... .. .	14

## DESCRIPTION

**1 DC supplies**

(a) Two 6000-watt engine-driven generators supply the whole of the electrical system and charge two 24-volt batteries connected in parallel. Minimum RPM to keep the batteries fully charged are 3700 with both generators running.

(b) An external ground supply socket is accessible via the radio bay door and is for use when a ground DC battery is necessary for servicing purposes.

**2 Standby DC supplies**

An emergency battery is provided to supply, through separate switches, the emergency lamps and the turn and slip indicator. If fully charged, the battery supplies between 7 and 20 hours continuous use, depending on the load imposed on it. A second emergency battery provides an emergency supply for the standby UHF set. ▶

### 3 AC supplies

(a) AC supply is from four type 100A inverters divided into two groups. No. 1 group comprises No. 1 (main) and No. 4 (standby) inverters which supply the Mk. 4FT compass, the cockpit temperature amplifier and top temperature controller. In addition, No. 4 inverter acts as a control to the radar ranging type 206 inverter, provided that No. 1 inverter is in circuit. If No. 1 inverter fails, radar ranging is impossible since No. 4 inverter takes over the other supplies. No. 2 group comprises No. 2 (main) and No. 3 (standby) inverters which supply the artificial horizons, Mk. 22F altimeter, vibrator for Mk. 19b or f altimeter and the oil pressure gauge.

(b) When the engine master switch is set to ON, both standby inverters start up. When the engine is started and the generators are on line the two main inverters take over the supply.

(c) Post Mod. 1321, a Type 108 inverter provides AC supply for TACAN. The inverter starts up when the aircraft becomes airborne and microswitches are operated by the raising of the landing gear. A ground test switch is provided on the generator control panel for servicing purposes only. (When Mod. 1356 is embodied, this inverter also supplies IFF/SSR).

### 4 Inertia switches

In the event of a crash landing, the generators and batteries are automatically isolated by the operation of four inertia switches. Each generator is isolated by its own inertia switch so that only one generator is lost in the event of accidental operation of a switch. The remaining two switches are connected in series and when operated isolate the batteries and automatically discharge the fire extinguisher bottle.

## CONTROLS AND INDICATORS

### 5 Generator controls and indicators

(a) The generators each have a separate control panel in the radio bay. No pilot-operated controls are fitted.

(b) A warning light for each generator, below the port instrument panel, comes on when its associated generator is not supplying power.

(c) On the generator control panel are two TEST/NORMAL switches for servicing purposes only.

## 6 Main battery control

The battery master switch below the port instrument panel, when set to OFF, isolates the aircraft main batteries from all electrical services except the engine fire extinguisher inertia switch circuit, the canopy switch circuit and the refuelling circuits. ▶

## 7 Standby battery controls

(a) The supply to the turn and slip indicator is controlled by the TURN and SLIP NORMAL/EMERGENCY switch below the instrument. With the switch set to EMERGENCY the instrument is supplied by the emergency battery.

(b) The EMERGENCY LIGHT — ON/OFF switch, when set to ON, allows the emergency battery to supply the emergency lamps.

## 8 AC supply — controls and indicators

(a) The engine master switch normally controls the DC input to the inverters, but No. 1 and No. 2 inverters do not come into circuit until the engine is started and the generators are on line. Two indicators on the centre pedestal, one for each group, give the following indications:

OFF (red)	— No inverter running
STANDBY (amber)	— Standby inverter running, main inverter not running
MAIN (green)	— Main inverter running, standby inverter not running.

Adjacent to the pupil's artificial horizon is a STANDBY INVERTER ON magnetic indicator which shows black when No. 2 inverter is supplying power and white if it fails.

(b) On the centre console are two NORMAL/STANDBY switches, one for each group. They may be used to test either standby inverter on the ground with the engines running, or in flight. They may also be used to attempt to bring a main inverter back into circuit (see para. 11).

(c) Post Mod. 1321, on the centre panel is a TACAN POWER SPLY — FAILURE indicator which shows black when the Type 108 inverter is running and white when there is a power supply failure. An adjacent RESET button may be used to attempt to re-start the inverter in flight or to cut-out the inverter after landing (Chap. 9, para. 7).

## 9 Warning indicators

<i>Service</i>	<i>Indication</i>	<i>Function</i>
Fire warning	1 red light	Gives warning when temperature in engine bay exceeds a pre-determined level.
Fuel pressure warning	1 red light	Indicates fuel pressure below 3 to 3½ PSI at engine inlet.
Fuel transfer warning	2 white magnetic indicators	Indicate failure of transfer system.
Fuel outboard tanks	2 white magnetic indicators	Indicate transfer from out-board drop tanks complete.
Booster pump	2 amber lights	Indicate failure of associated pumps.
HP pump isolation	1 red light	Indicates isolation in use.
Engine anti-icing	1 window	Indicates: OPEN — Red SHUT — Green De-energised — Yellow
Generator failure warning	2 red lights	Indicate generator(s) not on line.
Radar ranging warning	1 white magnetic indicator	Indicates radar ranging in use.

<i>Service</i>	<i>Indication</i>	<i>Function</i>
Oxygen	3 striped magnetic indicators	Indicate respective pilot inhaling (2 indicators for the instructor).
Inverters	1 white magnetic indicator	Indicates No. 2 failed.
	2 windows	Indicate state of inverters OFF — Red STBY — Amber MAIN — Green.
Braking parachute	2 red lights	Indicate parachute streamed.
Hydraulic failure warning	1 red light	Indicates hydraulic pressure below 600 PSI.
Landing gear position	3 red or green lights	Indicate position of each landing gear unit separately. No light — unit locked up Red light — unit between locks Green light — unit locked down.
Landing gear warning	1 red light	Indicates when throttle less than $\frac{1}{3}$ open and landing gear not locked down.
Powered controls	2 pairs of white magnetic indicators	Indicate separately disengagement of aileron or elevator hydro-boosters, or fault in electrical circuit.

<i>Service</i>	<i>Indication</i>	<i>Function</i>
Airbrake position	1 white magnetic indicator	Indicates airbrake not fully in.
TACAN power supplies	1 white magnetic indicator	Indicates AC or DC power failure.
Cockpit pressure warning	1 red light	Indicates drop of $\frac{1}{2}$ PSI in cabin pressure differential.
Telebriefing	1 amber light	Indicates telebriefing in use.
Canopy	1 green light	Indicates canopy locked closed with wheels down.

## NORMAL USE OF THE SYSTEM

### 10 Pre-flight procedures

(a) Before starting the engine, switch on the battery master switch and check the functioning of all DC operated instruments and indicators.

(b) When the engine master switch is set to ON, check that the No. 3 and No. 4 inverters start up (indicators STBY), that the STANDBY INVERTER indicator shows white and that the instruments are functioning.

(c) After start up, check generator warning lights out, main inverters start up (indicators MAIN) and STANDBY INVERTER indicator black. Then select STANDBY on each inverter changeover switch checking that the associated inverter indicator shows STBY. Also check that the STANDBY INVERTER indicator shows white when the No. 2 group changeover switch is at STANDBY. Re-select each changeover switch to NORMAL and check that the inverter indicators are at MAIN and that the STANDBY INVERTER indicator is black.

NOTE: The changeover check may be carried out in the air. There is a distinct noise change when inverter changeover takes place.

## MALFUNCTIONING OF THE SYSTEM

### 11 Inverter failure

If either main inverter fails, the standby inverter takes over the load automatically. An attempt may be made, either on the ground or in the air, to reset a main inverter by setting the appropriate NORMAL/STANDBY change-over switch to STANDBY and then returning it to NORMAL. If the associated indicator then shows MAIN, and in the case of the No. 2 group, the STANDBY INVERTER magnetic indicator reverts to black, resetting has been accomplished. If the indicators show that the standby inverter is in operation, resetting is not possible.

### 12 Single generator failure

If one generator fails, the other provides sufficient output for all electrical services provided engine RPM are kept above 5,000. To avoid overloading the remaining generator, however, the radar ranging and tailplane interconnection should be switched off. Except for operational reasons, a return to base should be made as soon as possible in case the remaining generator fails.

### 13 Double generator failure

(a) If both generators fail, all electrical services will be supplied by the batteries. These, if fully charged, will maintain the following output before they fail (i.e. battery voltage below 16 volts).

Output-amps.	180	150	125	100	75	50
Time-Mins.	5	7	10	15	20	30

(b) Failure to relight may involve gliding back to base, during which time all electrical loads should be reduced to a minimum to conserve enough power to operate the fire-extinguisher and brake parachute. The turn and slip indicator should be operated from the emergency battery for greater reliability in the final stages and the E2B compass used as far as possible to avoid unreliability of the Mk 4FT compass with dropping battery voltage. Engine windmilling RPM will provide little or no generation.

(c) To assist the pilot in deciding which loads should be shed, if generator failure occurs, the following table lists the major services and the current they require.

	<i>Service</i>					<i>Load (amps.)</i>
Radar ranging	...	...	...	...	...	46
Booster pumps	...	...	...	...	...	30
*AC inverters	...	...	...	...	...	22
Tailplane actuator and interconnection					...	20
*Type 108 inverter (TACAN)			...	...	...	35
UHF (ARC 52)	...	...	...	...	...	17
DME	...	...	...	...	...	7
IFF/SSR	...	...	...	...	...	5
Gun firing	...	...	...	...	...	10
Pressure head heater	...	...	...	...	...	6
RP firing	...	...	...	...	...	5
Starter control (relighting)			...	...	...	5
GGs	...	...	...	...	...	4
Intercomm.	...	...	...	...	...	2.5
*Fuel contents gauges	...	...	...	...	...	1.5
All other electrics	...	...	...	...	...	7

\*These items cannot be off-loaded in flight.

NOTE 1: The average flight load is 126 amps.

NOTE 2: When TACAN is installed (Mod. 1321) DME, Radar ranging and gun armament are removed.

#### 14 Double generator and battery failure

Once the batteries are discharged, no electrical services may be operated, e.g., trim tab actuators, tailplane motors, electro-hydraulic selectors, etc. The fuel gauges, Mk. 4FT compass and electrically-operated flight instruments will become unserviceable. The fuel booster-pumps cease operation, entailing reduction in altitude and engine RPM to ensure satisfactory engine running. No relight or fire extinguisher facilities are available when the batteries are fully discharged.

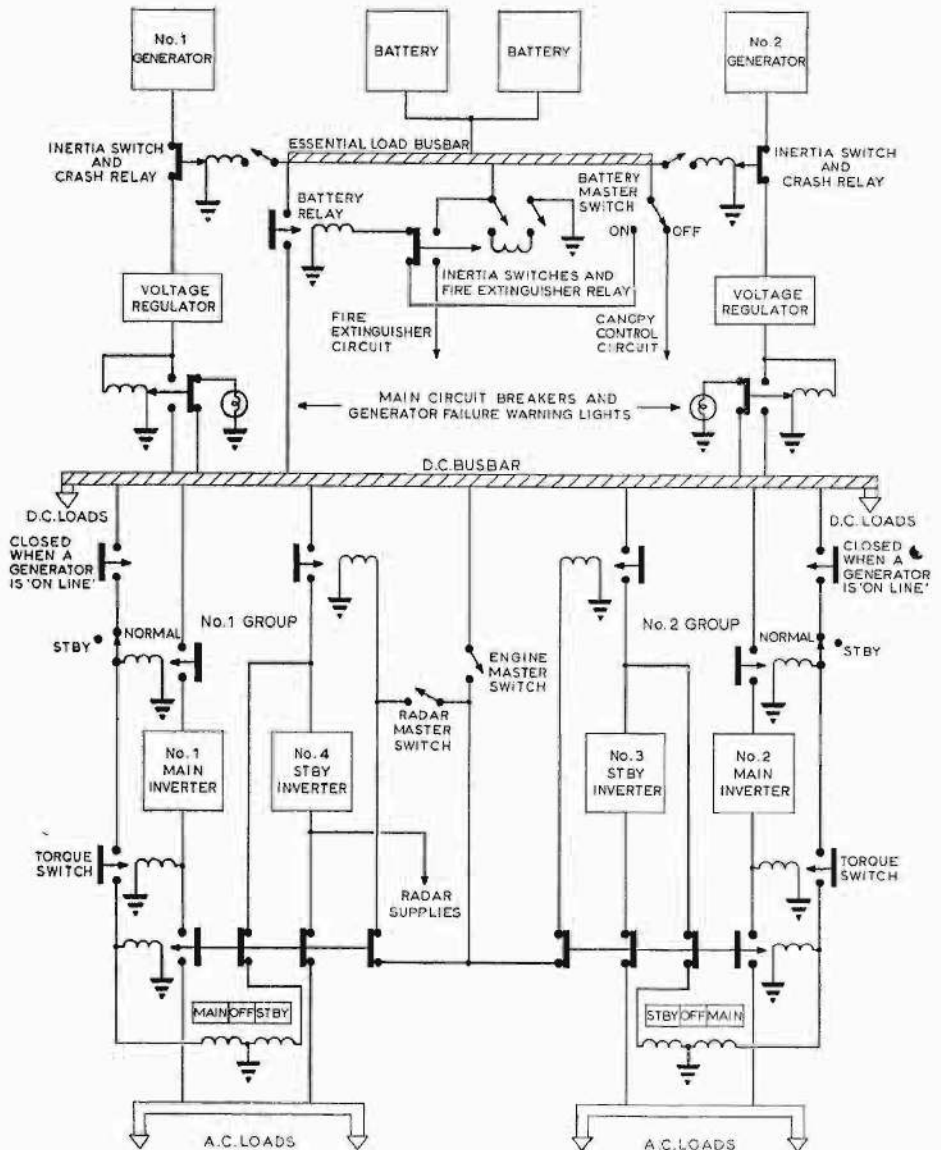

Hunter T7 — Electrical Supply System (simplified)

RESTRICTED



## PART 1

## Chapter 4 — HYDRAULIC SYSTEM

DESCRIPTION	Contents	Para.
Hydraulic system	... ..	1
<b>MALFUNCTIONING OF THE SYSTEM</b>		
Hydraulic failure	... ..	2

**DESCRIPTION****1 Hydraulic system**

(a) An engine-driven pump draws fluid from a reservoir in the engine bay on the port side of the aircraft. The pump maintains a live-line pressure of 2,850  $\begin{matrix} +150 \\ -50 \end{matrix}$  PSI for the normal operation of the:

- Landing gear and doors
- Landing gear recuperators
- Flaps
- Wheel brakes
- Aileron and elevator hydroboosters
- Airbrake
- Cockpit canopy
- Windscreen wipers

The main pressure is indicated by the central needle of the triple pressure gauge at the forward end of the port shelf.

(b) Five hydraulic accumulators are provided in the system to give a reserve of power in an emergency. The relevant details of these accumulators are given in the table below:

<i>Service</i>	<i>No. of Accumulators</i>	<i>Initial Air charge pressure</i> PSI	<i>Location of Pressure Gauge</i>	<i>Location of Charge Point</i>
Wheel-brakes	2	750	Port Shelf	Nosewheel Bay
Ailerons	1	900	Starboard wheelbay	
Elevators	1	1,575	Port side of fin	
Canopy	1	1,575	Behind radio access door.	

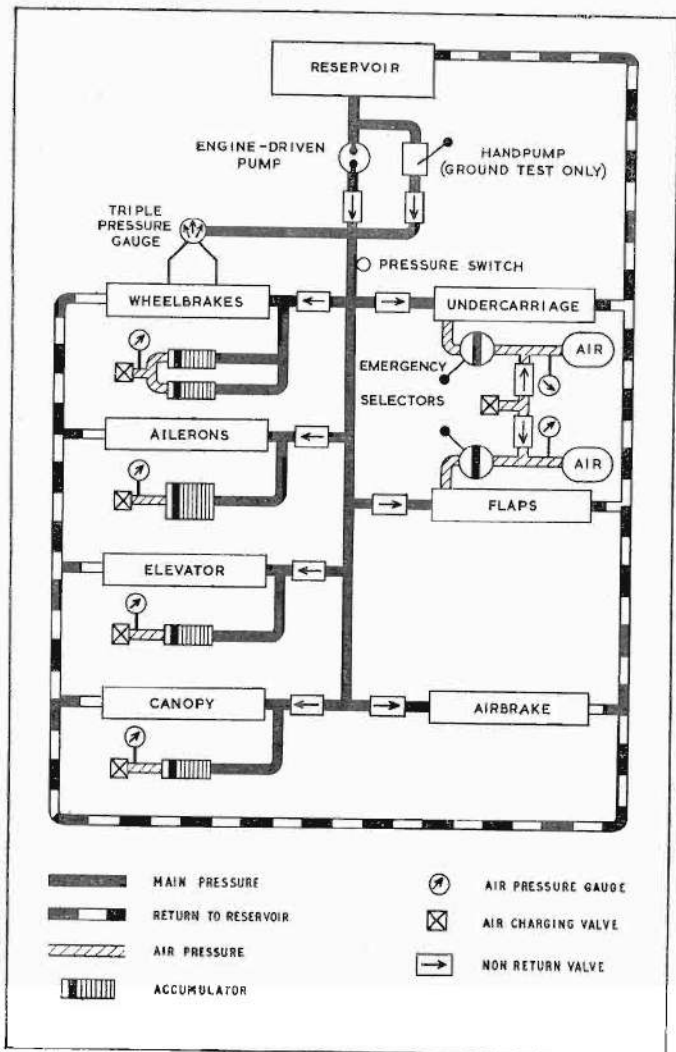

Hydraulic system diagram

(c) Indication of failure of the live-line system is controlled by a pressure switch, set to close when system pressure falls to 600 PSI. Whenever the switch closes, a red light on the port quarter panel illuminates and a high pitched noise over the pilots' headsets is heard. Confirmation can be obtained from the reading of the main needle of the triple pressure gauge on the port shelf. The audio-warning OUT/ON/OFF switch, when set to OUT, silences the warning once it has been given; the switch is spring-loaded to the ON position, but once OUT has been selected, the warning noise remains silenced through the operation of a hold-on circuit in the relay. If pressure builds up again to above 600 PSI, however, the system is reset and operates if failure again occurs. A guard must be raised before the switch can be set to the OFF position, at which the warning facility is rendered inoperative.

## MALFUNCTIONING OF THE SYSTEM

### 2 Hydraulic failure

(a) Check the triple pressure gauge periodically in flight. The central needle should normally read 2,850  $\begin{matrix} +150 \\ -50 \end{matrix}$  PSI. If the reading drops substantially below this figure when no service is being operated, then hydraulic failure should be suspected. The red warning light, and the audio warning should come on if the pressure falls below 600 PSI.

(b) If the hydraulic supply pressure fails, there may be sufficient reserve in the power controls accumulators for  $1\frac{1}{2}$  to  $2\frac{1}{2}$  full reversals of aileron and elevator, the actual reserve depending on the state of charge of the respective accumulators at the time of failure. However, even if no control movement is made, accumulator pressure is not maintained for a long period, due to normal hydraulic component seepage. When the accumulators are exhausted the controls revert automatically to Manual. It is important, therefore, that any asymmetric stores should be jettisoned, before Manual reversion occurs. (See Part 3, Chapter 4, para. 3 (d).)

(c) A failure in the power controls hydraulic circuit, as distinct from supply failure, may lead to immediate and automatic Manual reversion.

RESTRICTED

## PART 1

## Chapter 5 — POWERED FLYING CONTROLS AND TRIMMERS

### Contents

DESCRIPTION	Para.
Flying controls ... ..	1
Hydraulic power reserve ... ..	2
Tailplane and elevator ... ..	3
Tailplane and elevator interconnection ... ..	4
Aileron gear change ... ..	5
<b>CONTROLS AND INDICATORS</b>	
Aileron and elevator power — controls and indicators ...	6
Tailplane — controls and indicator ... ..	7
Tailplane and elevator interconnection — selector and indicator ... ..	8
Aileron feel and trim ... ..	9
<b>NORMAL USE OF THE POWERED CONTROLS</b>	
Pre-flight checks ... ..	10
Checks after landing ... ..	11
<b>MAI.FUNCTIONING OF THE POWERED CONTROLS</b>	
Bypass hydrobooster failures ... ..	12
Tailplane malfunctioning ... ..	13

### DESCRIPTION

#### 1 Flying controls

##### (a) *In power*

The ailerons and elevator are power-operated by hydraulic oil under pressure from the aircraft hydraulic system. A hydrobooster consisting of a servo valve and jack body and a piston is fitted close to each control surface. The control column is connected direct to the servo valve operating spindle so that depending on the direction of movement of the control column, the valve opens to admit pressure oil to one side of the jack piston and at the same time the other side is opened to return. The piston rod is anchored to the aircraft structure. The jack body is directly connected to one end of the control surface. When hydraulic

pressure is fed from the servo valve to one side of the jack piston, the jack body moves relative to the piston and deflects the control surface. When control column movement ceases, the servo valve closes causing a hydraulic lock which prohibits further movement of the jack body and control surface.

*(b) In Manual*

Manual operation of the controls may be selected deliberately by a switch in the cockpit provided that electrical power is available, or will happen automatically if hydraulic pressure falls below 200 PSI. As soon as pressure falls below that figure a bypass valve in the jack opens and allows the residual fluid in the jack to be pumped from one side of the jack piston to the other. When operating in Manual the jack bodies move freely with the control surfaces, but the bypass facility prevents the higher stick forces which would otherwise exist.

*(c) When Power is selected ON*, the bypass valve closes automatically as hydraulic pressure rises above 400 PSI. The controls are then in Power; the appropriate magnetic indicator shows black when pressure rises above 600 PSI. If hydraulic failure occurs or Power is selected OFF, the indicators show white as hydrobooster pressure falls below 600 PSI and the bypass valve opens automatically below 200 PSI. The controls are then in Manual.

## **2 Hydraulic power reserve**

Accumulators are fitted in the powered control circuits to provide a reserve of power if the main hydraulic supply fails. This reserve may be sufficient for  $1\frac{1}{2}$  to  $2\frac{1}{2}$  complete cycles of aileron and elevator operation before the controls revert automatically to Manual but, even if no control movement is made, accumulator pressure is not maintained for a long period due to seepage through the hydraulic components. With some types of hydraulic failure immediate reversion to Manual results.

## **3 Tailplane and elevator**

*(a)* An electrically-operated variable incidence tailplane is provided. It is hinged at the rear end, while a projection on the leading edge is connected to an electrically-operated actuator in the dorsal fin below the tailplane. After trimming to the required tailplane angle to give zero stick force for a given flight condition, the elevator is trailing with no air load imposed on it.

(b) The tailplane actuator is operated by one of two electric motors, the main and standby. The standby motor, which is fitted to meet the case of failure of the main motor or its electrical supply, operates at about one-third the rate of the main motor.

(c) The air loads on the elevator are resisted entirely by hydraulic jack effort, no load being felt on the control column. To provide control feel, a spring is fitted in the control circuit between the control column and the variable incidence tailplane. The spring gives an artificial feel to the elevator control circuit by imposing a force proportional to stick deflection but not airspeed (i.e., air loads).

#### 4 Tailplane and elevator interconnection

##### (a) General

An electrical interconnection enables the variable-incidence tailplane to follow up elevator movements automatically, giving greater manoeuvrability at high mach numbers.

##### (b) Function

(i) A lift-gated TAILPLANE -- ON/OFF switch on the centre panel controls the operation of the tailplane and elevator interconnection. The interconnection, in the form of a follow-up linkage attached to the elevator, provides a pre-determined tailplane and elevator movement for a given control column deflection. It functions irrespective of whether the elevator is in Power or Manual, when TAILPLANE is selected ON and a DC supply is connected. The linkage carries a switch arm which moves between two microswitches in circuit with the tailplane actuator. Movement of the elevator relative to the tailplane causes the switch arm to operate one of the microswitches. The tailplane actuator then moves the tailplane to follow the elevator. When the tailplane reaches the appropriate setting for the control column deflection, the switch arm is back to its neutral position between the microswitches; the tailplane stops moving, leaving the elevator deflected relative to the new position of the tailplane.

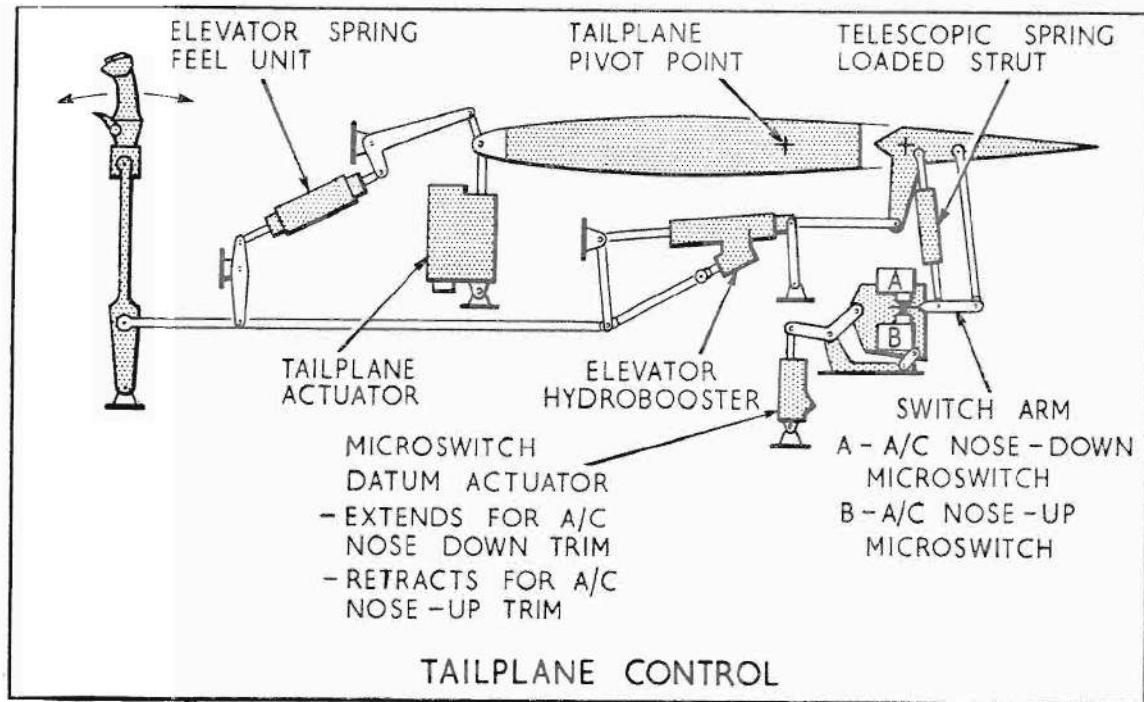

(ii) To prevent continual hunting of the tailplane actuator, the elevator has a small range of movement over which the microswitches are not selected. Thus if the elevator is deflected and then returned to its original position the trim indication does not return fully to its previous setting.

(iii) A spring-loaded telescopic strut is incorporated in the linkage so that full and unrestricted stick movement is always obtainable. The strut telescopes when either the elevator is moved faster than the rate at which the tailplane actuator can follow up or when the tailplane has reached the end of its travel.

(iv) Use of the main trimmer control overrides the operation of the follow-up tail.

### (c) *Trimming*

Trimming is carried out by means of the variable-incidence tailplane actuator main motor switch, or by a standby motor switch should the main motor or its switch fail to function. In addition to altering the tailplane incidence, operation of the main switch also resets the datum position of the two microswitches. During trimming the elevator is kept in line with the tailplane by the centring action of the spring feel strut, the switch arm thus following the resetting of the microswitches datum position. The datum setting is not altered when the standby switch is operated. ▶

## 5 Aileron gear change

(a) Provision is made for altering the aileron gear ratio so that, for the same stick movement, aileron travel in Manual is approximately two-thirds of that obtained in Power.

(b) A hydraulic jack is fitted in the aileron control linkage and, when extended by aileron hydraulic pressure, alters the effective arm of the aileron control linkage. When there is no hydraulic pressure the jack retracts under spring pressure.

## CONTROLS AND INDICATORS

### 6 Aileron and elevator power -- controls and indicators

- (a) (i) Two Power ON/OFF selector switches on the port instrument panel, control electrically the hydraulic cocks, one for the aileron circuit and the other for the elevator circuit. When the engine is running and a switch is selected ON, hydraulic pressure is fed to that circuit.
- (ii) Two additional switches are on the starboard shelf so that the instructor may select Power OFF at any time. Power engagement by the pupil's switches is only possible if the instructor's switches are ON.
- (b) (i) Two magnetic indicators, one for the aileron circuit and one for the elevator are beside the selector switches on the port instrument panel; they show black when the controls are in Power and white when the controls are in Manual or alternatively when electrical power to the indicator is not available. A similar pair of magnetic indicators, above the starboard artificial horizon, is provided for the instructor's use.
- (ii) An audio warning over the pilot's head-set warns the pilot if hydraulic system pressure falls to 600 PSI. Further warning is given by a red hydraulic failure warning light and the reading of the hydraulic pressure gauge.
- (c) A white datum spot is painted on the instrument panel at each station and is used for spin recovery. Alignment of the top of the stick with the spot corresponds to the aileron neutral position.

### 7 Tailplane — controls and indicator

- (a) The tailplane main motor is controlled by a thumb switch on the top of the control column. The instructor's switch overrides the pupil's switch. A circuit breaker under a flap on the starboard shelf may be used to cut out the main trim circuit.
- (b) The standby motor is controlled by a switch under a cover on the port shelf. The cover must be raised *fully* to ensure that the circuit breaker, protecting the main motor circuit, is tripped before the switch is operated.
- (c) The setting of the tailplane is shown on an indicator on the port instrument panel.

## **8 Tailplane and elevator interconnection — selector and indicator**

(a) A TAILPLANE — ON/OFF switch, on the centre panel, controls the selection of tailplane and elevator interconnection. The tailplane indicator shows when the tailplane is functioning as a flying control, i.e., the indicator moves when the control column is deflected as well as when the trim switch is actuated.

(b) The circuit is so arranged that when the cover of the standby trim switch is raised, both the main actuator and the interconnection are isolated.

## **9 Aileron feel and trim**

(a) The air loads are resisted entirely by the hydraulic jack effort and no load is fed back to the control column. To provide control feel, a spring is fitted in the control circuit and gives an artificial stick force which is proportional to aileron deflection but not to airspeed. A handwheel on the left-hand side of the control column provides spring feel adjustment and may be used to trim the aircraft when in Power. A white line is inscribed on the handwheel. When the trimmer is neutral the line points forward and the trimmer engages in a spring-loaded detent. Movement from this position is through 300° either to the left or to the right thereby adjusting the zero force position of the stick. This trimmer should not be used in Manual.

(b) A trim tab is fitted on the port aileron. It is only intended for use in Manual and a guard is placed round each combined rudder/aileron trim control to prevent the inadvertent use of aileron trim when in Power. A trim indicator is forward of each control. The pupil's trim control is inoperative when the guard on the instructor's control is swung clear of the control. The instructor's control provides aileron trim only. The guards on the controls may be left off for take-off and landing in case of Manual reversion.

## NORMAL USE OF THE POWERED CONTROLS

### 10 Pre-flight checks

#### (a) *Ailerons and elevator*

(i) After starting, select the power control switches to ON. Check that the magnetic indicators go black.

(ii) Immediately before take-off, check the controls over full range at not less than 4,500 RPM and ensure the magnetic indicators remain black.

#### (b) *Follow-up tailplane and tailplane trim*

(i) With the stick free and tailplane angle at zero, select TAILPLANE ON. Move the stick fore and aft over the full range. During this check, trim in the reverse direction to stick movement and check that the trim operation overrides the follow-up tail. Note that this action repositions the datum actuator and, when the stick is released, the tailplane takes up a new position.

(ii) Retrim to zero on the main trimmer to reset the datum actuator. Whilst moving the stick, raise the cover of the standby trim to check the cut-out. Check the operation of the standby trim, leaving the tailplane  $1^\circ$  away from zero. Lower the cover of the standby trim fully and check that the tailplane reverts to the zero position  $\pm \frac{3}{4}^\circ$  with the stick free. Switch TAILPLANE OFF.

(iii) Operate the main trimmers, checking that the instructor's control overrides that of the pupil, and leave at the take-off position.

### 11 Checks after landing

(a) To assist in servicing the bypass boosters after landing in Power, Manual should be selected prior to stopping the engine, so that the supply lines to the boosters are closed. This enables the handpump circuit to be used by the ground crew. If the controls are in Power when pressure is dissipated, the supply lines to the boosters are open and the handpump rendered ineffective because it cannot develop enough flow and pressure to shut the bypass valves which offer a path to return. For the same reason sufficient pressure cannot be built-up for the electro-

hydraulic selector valves to move if selected to Power OFF. Additionally it is not possible to operate the canopy since accumulator pressure is not maintained.

(b) When Mod. 895 is embodied, provision is made for Manual selection for servicing purposes and the foregoing is no longer essential.

## MALFUNCTIONING OF THE POWERED CONTROLS

### 12 By-pass hydrobooster failures

(a) *By-pass valve fails to open when Power is selected OFF*

(i) The aileron and elevator loads in Manual are slightly increased compared to normal Manual due to the elimination of the bypass facility. The increased loads are acceptable however.

(ii) Reselecting Power ON, if this is possible, eliminates the fault but it will probably recur if Power OFF is again selected.

(b) *Aileron bypass valve fails to shut when Power is selected ON*

(i) This gives a condition of one aileron in Power and one in Manual.

(ii) It is relatively easy to detect on the ground as the stick judders when moved laterally and operating loads are somewhere between normal Power and bypass Manual.

(iii) In flight there is a wing-low tendency, caused by the upfloat of the Manual aileron, which increases with increased airspeed. The stick force to maintain lateral level does not exceed 20 lb. in level flight.

(iv) Increase of G increases the out-of-trim condition.

(v) The wing-low tendency is reduced when the flaps are lowered.

(vi) Recommended action is to select Power OFF.

◀(c) *Servo valve operating spindle breaks when controls are in Power*

(i) Further movement of the jack body and control surface is prohibited by closure of the servo valve.

(ii) The control column will remain in a deflected position.

(iii) Selecting Power OFF enables the jack body to move freely and normal Manual control will be available. ▶

### **13 Tailplane malfunctioning**

(a) If the follow-up tailplane malfunctions, either in its capacity as a flying control or in its trimming action, the standby trim switch cover must be lifted immediately. The standby actuator can then be used to obtain satisfactory trim. It is possible that malfunctioning may not affect the main trim actuator with TAILPLANE selected OFF although it might have shown itself during either normal control movement or trimming with TAILPLANE ON. After raising the standby trim switch cover, select TAILPLANE OFF, then reselect the main actuator and check the normal trimming action. If the malfunction is still present, revert to the standby actuator and return to base.

(b) If the tailplane trim actuator runs away, lift the standby trim cover *fully* or operate the instructor's tailplane cut-out switch. Control can then be regained by use of the standby trim switch.

## PART 1

## Chapter 6 — OTHER AIRCRAFT CONTROLS AND FLIGHT INSTRUMENTS

### Contents

					Para.
Rudder pedals adjustment and rudder trim	...	...	...	...	1
Flying controls locking gear	...	...	...	...	2
Landing gear normal control	...	...	...	...	3
Landing gear emergency control	...	...	...	...	4
Flaps normal control	...	...	...	...	5
Flaps emergency control	...	...	...	...	6
Airbrake control	...	...	...	...	7
Wheelbrakes control	...	...	...	...	8
Braking parachute control	...	...	...	...	9
Electrically-operated flight instruments	...	...	...	...	10
Pressure-operated flight instruments	...	...	...	...	11
Accelerometer	...	...	...	...	12
Windscreen wipers	...	...	...	...	13

### 1 Rudder pedals adjustment and rudder trim

(a) Each pair of rudder pedals is adjustable for leg reach by means of a control at the bottom centre of each pilot's instrument panel. When the control is pulled out, a plunger is dis-engaged from a hole in the adjusting shaft, thus allowing the rudder pedals to be pushed forward against the pressure of a spring, or to swing aft by spring pressure. When adjustment is complete, releasing the control to allow the plunger to engage in the nearest hole fixes the rudder pedal in the desired position.

(b) The rudder trim tab is actuated electrically by the pupil's combined aileron/rudder trim control, regardless of the position of the trim lock. (The instructor's control does not provide rudder trim and is used for aileron trim only.) Tab position indicators are forward of the controls.

### 2 Flying controls locking gear

#### (a) *Internal locking*

The internal locking devices consist of two clips designed to attach to the control column. One has two tongues

on its forward face; this clip should be attached to the control column, pushed down until the tongues are positioned firmly between the aileron stops and secured by tightening its wing bolt. The other clip, which has four cables attached, should then be secured to the control column. The other ends of the cables incorporate hooks which should be attached to holes in the cross member at the top of the appropriate ejection seat pan and to the outboard edges of the rudder pedals.

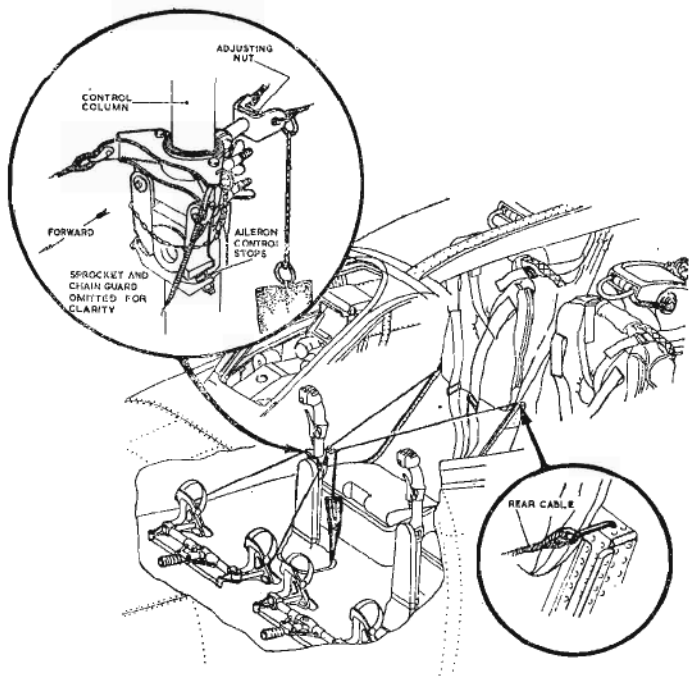

FLYING CONTROLS LOCKING GEAR

### (b) External locking

Locking clamps are provided for all flying control surfaces.

NOTE: There is no control lock stowage in the aircraft.

## 3 Landing gear normal control

(a) Two selector pushbuttons UP and DOWN, are on the port side of the pupil's instrument panel. Three selector

pushbuttons, two labelled UP and DOWN and one coloured red, are on the starboard side of the instructor's instrument panel. When the red pushbutton is pressed in, landing gear selection is controlled by the pupil's pushbuttons and the instructor's pushbuttons are both in the out position. A selection of UP or DOWN by the instructor causes the red pushbutton to release, thereby cutting off the electrical supply to the pupil's pushbuttons which remain in their selected positions. The instructor then has full control of the landing gear but may pass control back to the pupil at any time by pressing in the red override button. This action is only possible if both pairs of selector pushbuttons are similarly selected and the battery master switch is ON.

**WARNING:** To prevent inadvertent landing gear operation if malfunction of the selector interlock occurs, it is essential that the instructor first ensures that the pupil's pushbuttons are similarly selected to his own before handing back control to the pupil.

(b) A standard position indicator is fitted to the left of the pushbuttons on the port panel. A warning light below the pushbuttons comes on if the throttle is less than one-third open with the landing gear not locked down.

#### 4 Landing gear emergency control

(a) Should electrical or hydraulic failure occur, the landing gear may be lowered irrespective of the position of the normal selector buttons by pulling the landing gear emergency lowering control on the port shelf, after first pushing in the central knob. This admits air from an emergency bottle to the wheel unit jacks, by-passing the landing gear sequence valves, forcing the jacks to lower and lock. The available air pressure (2,000 PSI min.), is shown on a gauge at the aft end of the port shelf.

(b) If it is required to retract the landing gear *on the ground only* either UP selector pushbutton should be twisted clockwise and then pressed; the buttons may rotate through 60° or 90° according to the type fitted. This is inoperative if the landing gear emergency system has been used.

## 5 Flaps normal control

(a) The flaps are selected electrically, and operated hydraulically. Selection is by means of a lever, on the outboard side of each instrument panel, which provides UP, DOWN (80°) and six intermediate positions (15°, 23°, 30°, 38°, 45°, 60°).

(b) A safety catch is provided on the instructor's selector lever which must be released to move the lever upwards into a gate beyond the fully UP position and downwards from that position. Only when the lever is in the gate is the pupil's selector operative. Any selection by the instructor cancels a selection made previously by the pupil.

(c) The flaps may be selected to any of the above positions but the extent to which they lower depends upon the air loads. If speed is increased with the flaps extended, the angle is adjusted according to the air loads; however, the flaps will not be fully retracted (see Part 3, Chapter 2, para. 3 (f)).

(d) When the aircraft is being flown solo, or when the pupil is in control, the instructor's selector lever must be gated beyond the UP position. If the instructor wishes to take control or to override a pupil's selection, movement of his lever out of the gate cuts off electrical supply to the pupil's selector. When the instructor hands back control to the pupil, it is essential that he ensures that the pupil's selector is in the fully UP position otherwise the flaps will move to the position selected by that lever.

(e) A flap position indicator is fitted on the port instrument panel.

## 6 Flaps emergency control

Should electrical or hydraulic failure occur, the flaps may be lowered *fully down* by air from an emergency air bottle. When the FLAPS EMERGENCY LOWERING control on the port quarter panel is pulled, after first pressing in the central knob, the air is directed to the lowering jacks. The available pressure (2,000 PSI min.) is shown on a gauge at the aft end of the port shelf.

## 7 Airbrake control

(a) An under-fuselage airbrake is provided; it is electrically selected and hydraulically operated and extends fully at any speed.

(b) Control of the airbrake is by means of a three-position switch, spring-loaded to the central off position, on each throttle lever. No position other than fully in or fully out can be selected. A magnetic indicator on the port instrument panel shows black only when the airbrake is fully in.

(c) The airbrake is automatically inoperative when the landing gear is lowered. If the landing gear is lowered when the airbrake is out, the airbrake automatically retracts. *Airbrake IN must not normally be obtained by selecting landing gear DOWN.*

(d) A spring-loaded switch on the centre pedestal enables the airbrake to be tested on the ground. When the switch is held to TEST the airbrake extends through 10° only and then retracts with a slight bump. The indicator shows white momentarily when the airbrake is out.

## 8 Wheelbrakes control

(a) The wheelbrakes are operated hydraulically by means of a lever attached to the forward face of each control column and a differential relay controlled by the rudder pedals.

(b) The live-line pressure ( $2,850 \pm \frac{150}{50}$  PSI) is shown on a triple pressure gauge together with the pressure at each main wheel (1,500 — 1,650 PSI).

(c) Should the hydraulic system fail, the pressure in the wheelbrakes accumulator, which, if fully charged should provide sufficient pressure for about 40 operations of the units, is sufficient for landing but leaves little in hand for subsequent taxiing. The available accumulator pressure is shown on a gauge at the forward end of the port shelf. The brakes function with reducing effectiveness until accumulator pressure drops to 750 PSI, when no further braking is available. ▶

(d) Maxaret brake units are fitted. The units can come into operation only if the wheels are rotating and in no circumstances should the brakes be applied at touchdown.

## 9 Braking parachute control

(a) The braking parachute, stowed in a container above

the tail cone, is controlled either by the pupil's two-position OFF, JETTISON/STREAM switch or by the instructor's three-position JETTISON/off/STREAM switch. The two-position switch should normally be at OFF, JETTISON and the three-position switch in the mid (off) position. ◀Mod. 1111 introduces a guard for the pupil's switch. ▶

(b) Selection of the two-position switch to STREAM ejects the parachute. Returning the switch to OFF, JETTISON disconnects the parachute from the aircraft. The switch is only operative when the three-position switch is in the mid (off) position.

(c) Selection of the three-position switch to STREAM ejects the parachute. Returning the switch to off disconnects the parachute from the aircraft. The JETTISON position is for emergency jettisoning by the instructor if mal-operation of the parachute follows streaming action by the pupil.

(d) A STREAM caption is on a red warning panel on the coaming above the centre panel. The caption is illuminated by two lights which come on under any of the following conditions:

(i) When the parachute is streamed normally. The caption remains illuminated after jettison action is taken.

(ii) When the parachute bay doors open because of malfunction. In this event the parachute is ejected from its housing and jettisoned.

(iii) By operation of a TEST switch on the cockpit port wall. This indicates that the braking parachute electrical circuit is complete and the system is ready for use. It is important to ensure that the circuit breaker, adjacent to the TEST switch, is closed; otherwise the TEST switch and the control switches are inoperative. The TEST switch can be operated in flight.

(e) When it is ascertained that the parachute has jettisoned after landing, or if the parachute fails to jettison, return the control switch to STREAM immediately, otherwise the release unit may be damaged by the electrical overload.

## 10 Electrically-operated flight instruments

(a) The turn and slip indicator is operated by DC whenever electrical supply is available. If electrical supply is lacking, the word OFF appears in the face of the instrument. Below the instrument is a TURN & SLIP —

NORMAL/EMERGENCY switch. With the switch at NORMAL, supply is from the main batteries; with the switch at EMERGENCY, supply is from the emergency battery. An additional turn and slip indicator is fitted on the instructor's panel. It also has a NORMAL/EMERGENCY switch, below the instrument.

(b) (i) The pupil's Mk. 4 artificial horizon is operated by AC from the No. 2 group inverters. A power failure indicator is incorporated and shows the word OFF when electrical supply is lacking. The fast erection button must not be used until 15 seconds after switching on, and it must not be depressed longer than 1 minute or after the instrument has erected.

(ii) The instructor's Mk. 6C artificial horizon is also operated by AC from No. 2 group inverters. The fast erection button of this instrument must not be used until 30 seconds after switching on and must not be depressed longer than 1 minute or after the instrument has erected. The power failure indicator shows an orange and black disc when electrical power is lacking.

(iii) With both Mk. 4 and 6C artificial horizons, the fast erection button must only be operated in unaccelerated flight.

(c) The Mk. 4FT compass is operated by AC from the No. 1 group inverters. A compass correction panel is fitted at the rear end of the starboard shelf.

(d) A Mk. 22F altimeter, at the pupil's station, obtains its electrical supply from the No. 2 group inverters. (See para. 11 (d)).

## 11 Pressure-operated flight instruments

(a) Pitot and static pressures are provided by a pressure head, Mk. 9 series, on the leading edge of the port wing tip. The pressure head is electrically heated and the heater element is controlled by a switch below the centre of the port instrument panel.

(b) The following pressure-operated flight instruments are provided on both the port and starboard instrument panels:

(i) Airspeed indicator, Mk. 12A.

(ii) Machmeter, Mk. 3A.

(iii) Vertical speed indicator, Mk. 3Q.

(c) An altimeter, Mk. 19B or F, is fitted on the starboard panel for the instructor's use. This altimeter is fitted with an AC-operated vibrator to improve its performance; power is provided by No. 2 group inverters. The cockpit altimeter, on the centre panel, is not connected to the static pressure line but is left open to record the pressure in the cockpit.

(d) A servo-operated Mk. 22F altimeter on the port panel is supplied with AC from No. 2 group inverters. The instrument incorporates an override switch which prevents damage to the altimeter mechanism by cutting off the supply in the event of a servomotor runaway. This switch may also operate when a large transient rise in AC frequency occurs, such as when changing or restoring the power supply. When the override switch operates, the altimeter ceases to function and the OFF flag appears. If the altimeter OFF flag appears and remains, when the power supply is known to be connected to the instrument, an attempt should be made to re-set the override switch by selecting the maximum millibar setting and then, if necessary, the minimum setting. If the re-set attempt is successful, the OFF flag should disappear and the altimeter start to function. Accurate indications can be re-established by setting the sub-scale as required.

## 12 Accelerometer

The accelerometer on the centre panel indicates all accelerations imposed on the aircraft by means of three concentrically-mounted pointers. One pointer indicates instantaneous G the other two register the maximum positive and negative G readings respectively until re-set, ◀by operation of a knob on the instrument case. ▶

## 13 Windscreen wipers

A windscreen wiper is fitted to the windscreen in front of each pilot. The wipers are hydraulically operated and are controlled by a single, PARK/TURN TO RUN, knob located on the port instrument panel. Speed of operation of the wipers may be varied by adjustment of the control knob in the TURN TO RUN range. The wiper blades are of the parallel motion type. The wipers must not be used when the windscreens are dry nor should they be used at speeds in excess of 300 knots.

## PART 1

## Chapter 7 — GENERAL EQUIPMENT AND CONTROLS

### Contents

	Para.
Canopy operation ... ..	1
Canopy jettisoning ... ..	2
Cockpit pressurisation, heating and demisting ... ..	3
Management of cockpit pressurisation ... ..	4
Internal lighting ... ..	5
External lighting ... ..	6
Emergency equipment ... ..	7

### 1 Canopy operation

(a) The canopy which is hinged at its rear edge, is normally electro-hydraulically operated. Provision is also made for manual operation if electric or hydraulic failure occurs. An OPEN/off/CLOSED selector switch, spring-loaded to off, on the centre panel, is the normal operating control. When a selection is made there is a 3-5 second delay before the canopy moves and the selection must be held until the canopy completes its travel. A selection of OPEN will cause the canopy to open only when the battery master switch is OFF. If it is necessary to open the canopy when the battery master switch is ON, a spring-loaded HOOD OVERRIDE switch, on the cockpit port wall, must be held at OPEN and at the same time the normal control selected OPEN. A warning horn sounds when CLOSED is selected. When the canopy closes and the locks engage, a green indicator light adjacent to the control switch comes on. This light goes out when the landing gear is raised. Two transparent inspection panels, one on each side wall of the cockpit can be used to check the position of the canopy lock jack. When the canopy is closed and locked a bolt on each forward side lock should align with a white dot on the transparent panel.

(b) The canopy may be lifted off from inside by removing a pip-pin, attached by a chain to the first-aid kit stowage, from the operating rod to isolate the canopy jettison gun

and then operating a canopy release handle which is positioned centrally on the cockpit rear bulkhead (above the first-aid kit).

(c) The canopy may be opened or closed from outside by means of an OPEN/off/CLOSE switch in the nose-wheel bay, provided that the battery master switch is OFF. A hydraulic accumulator, if fully charged, provides for the canopy to be opened and closed three times before the accumulator becomes exhausted of fluid. The accumulator can be charged externally by use of the handpump (but see Part 1, Chapter 5, para. 11).

(d) A taxiing strut, on the front of the canopy, allows the canopy to be left partially open for taxiing. The strut is held in the extended position by a spring-loaded tube.

(i) To position the canopy in the partially open position, select canopy OPEN, pull backwards and down on the tube handle, then allow the spring to extend the strut, select canopy CLOSED.

(ii) To close the canopy fully, select canopy OPEN, pull the tube handle to retract the strut, then select canopy CLOSED.

NOTE: To open the canopy with the engine running the override switch must be used.

## 2 Canopy jettisoning

(a) The canopy is jettisoned by gas pressure from a jettison gun acting on two pistons which eject the canopy upwards and backwards. This action may be initiated by pulling the canopy jettison handle, at the rear of the centre pedestal.

(b) The canopy is also jettisoned automatically whenever either handle of either ejection seat is pulled.

### (c) *External emergency release*

An external emergency release ring is inside a break panel on the port side of the fuselage. When the release ring is pulled the canopy is ejected by the jettison gun.

**WARNING:** If this method is used all personnel must be clear of the vicinity of the aircraft. After pulling the ring the operator must immediately stand clear.

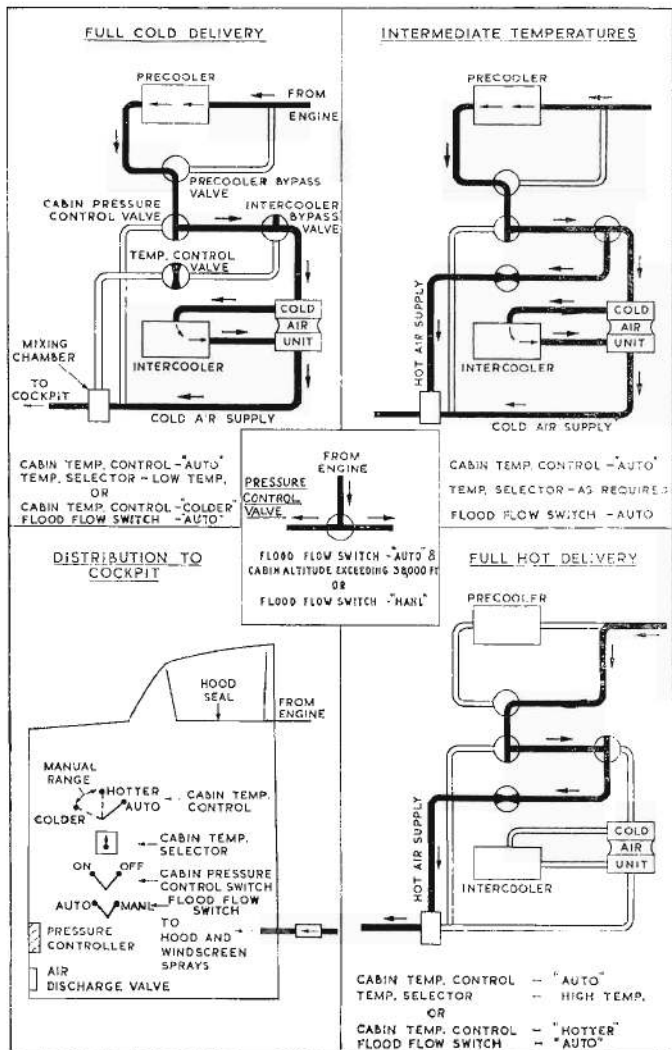

Cockpit pressurisation and air conditioning diagram

### 3 Cockpit pressurisation, heating and demisting

NOTE: The system is inoperative whenever the canopy is open.

(a) Hot air under pressure is bled from the engine compressor to supply the heating, pressurisation and demisting system. The air supply to the cockpit terminates in spray pipes which provide for windscreen, side panels and hood demisting.

(b) The controls are grouped at the aft end of the port shelf. Three ganged, COCKPIT PRESSURE — ON/OFF switches control air flow to the cockpit. When ON is selected air is supplied from the engine compressor; when they are selected OFF, ram air is supplied from an intake in the nose of the aircraft.

(c) A four-position temperature control lever is marked AUTO/COLDER/EMERGY/HOTTER. It is normally left selected at AUTO and a cockpit temperature selector control is used to select the desired temperature, a thermostat maintaining the selected temperature. If AUTO selection should fail, the controlling valve can be stopped by selecting EMERGY. Temperature can then be selected by inching the lever from EMERGY. to COLDER or HOTTER until the desired temperature is reached; the lever should then be left at EMERGY. A change from full cold to full hot cockpit temperature takes about 35 seconds.

(d) A FLOOD AIR FLOW — AUTO/MANUAL switch is normally set at AUTO; in this position if loss of cockpit pressure causes the cockpit altitude to exceed 38,000 feet, an altitude switch operates and supplies 'flood' air. If the switch is set to MANUAL, 'flood' air operates regardless of cockpit altitude; this is primarily intended for clearing transparency misting.

(e) A spring-loaded test switch, aft of the normal controls, simulates the automatic action of the altitude switch and allows the flood flow system and the cockpit pressure warning light to be tested.

(f) The cockpit pressure altimeter, on the centre panel, should indicate in accordance with the following table. If the cockpit pressure differential drops by more than  $\frac{1}{2}$  PSI a red lamp on the centre panel lights.

<i>Actual altitude</i>	<i>Cockpit altitude</i>	<i>Cockpit altitude at which warning lamp will light</i>
20,000 ft.	13,000 ft.	13,750 ft.
30,000 ft.	16,500 ft.	18,000 ft.
40,000 ft.	22,500 ft.	24,000 ft.

#### 4 Management of cockpit pressurisation

##### (a) *Pressurisation system*

(i) Before start up, check that the cockpit pressure warning light comes on by operating the cockpit pressure warning test switch to TEST.

(ii) The cockpit pressurisation switch should be set as required for take-off. In conditions of high humidity, leave it OFF until at 5,000 ft. on the climb.

##### (b) *Flood flow system*

For all normal conditions of flight the FLOOD AIR-FLOW switch should be at AUTO. To prevent windscreen misting MANUAL should be selected when necessary. During take-off the increase in airflow is considerable.

#### 5 Internal lighting

##### (a) *General*

Miniature pillar (single lamp) and bridge (double lamp) lighting is installed adjacent to the instrument panel components required to be illuminated. In addition hooded red lamps are provided for the port and starboard shelves and cockpit walls. All dimmer switches are separately fused.

##### (b) *Centre and port instrument panels*

Two dimmer switches on each panel control the lights for that panel; each switch controls one of the lamps in each bridge light. Exceptions are the single lamps which illuminate the artificial horizon failure indicator and oil pressure indicator on the port instrument panel and the braking parachute switch on the centre instrument panel; these are controlled by one dimmer switch from each pair.

(c) *Starboard instrument panel*

A single dimmer switch controls the lamps on the instrument panel. The lamps are mounted in pairs with the exception of the lamps for the instructor's oxygen contents indicator and power control switches.

(d) *Centre pedestal lamps*

Two white single pillar lamps on the centre pedestal are controlled by a single-pole ON/OFF switch.

(e) *Side red flood lamps*

Five lamps on the port side and two on the starboard side are controlled by two dimmer switches one on each side of the cockpit.

(f) *E2B compass lamp*

The compass lamp is controlled by a NORMAL/off/EMERGENCY switch, forward of the throttle box on the centre console. When set to NORMAL, power supply is from the bus-bar; when set to EMERGENCY, supply is from the emergency battery. With the switch at NORMAL or EMERGENCY the degree of illumination is controlled by a dimmer switch forward of the throttle box.

(g) *Emergency lamps*

Two emergency lamps on the centre panel are controlled by an on/off switch below them and are supplied by the emergency battery.

## **6 External lighting**

The navigation lights are controlled by a FLASH/off/STEADY switch on the centre panel.

## **7 Emergency equipment**

(a) *E2B compass*

This is on the windscreen arch above the centre panel.

NOTE: When swinging or otherwise checking the compass it is essential that the GGS recorder is stowed, the generators are on line, the canopy is fully closed, and the oos is switched OFF.

(b) *First-aid equipment*

A stowage for first-aid equipment is above the main fuse box on the bulkhead behind the pilots' seats.

(c) Two stowages, each containing two survival packs, are accessible via external panels on the port and starboard sides of the canopy fairing. A screwdriver, for the removal of the access panels, is stowed in the cockpit below the first-aid kit, behind the ejection seats.

RESTRICTED

## PART 1

## Chapter 8 — AIRCREW EQUIPMENT ASSEMBLY AND OXYGEN SYSTEM

<b>Contents</b>		<b>Para.</b>
General	... ..	1
<b>EJECTION SEAT</b>		
Ejection seat Type 4HA	... ..	2
Ejection gun and firing handles	... ..	3
Barostat/G-stop time delay	... ..	4
Manual separation handle and guillotine unit	... ..	5
Harness restraint apron	... ..	6
<b>ANTI-G SUIT SYSTEM</b>		
Anti-G suit system	... ..	7
<b>OXYGEN SYSTEM</b>		
Oxygen system — general	... ..	8
Regulators	... ..	9
Emergency bottles	... ..	10
<b>EMERGENCY USE OF THE OXYGEN SYSTEM</b>		
Toxic fumes	... ..	11
Regulator indicator failure	... ..	12
Regulator failure	... ..	13
Use of the emergency bottle	... ..	14
<b>USE OF THE AIRCREW EQUIPMENT ASSEMBLY</b>		
Strapping-in procedure	... ..	15
Normal exit procedure	... ..	16
Forced landing	... ..	17
Abandoning and ditching	... ..	18

**WARNING:** The aircraft is 'safe for parking' when safety pins are inserted in:

- Both ejection seat facescreen firing handles.
- Both ejection seat seatpan firing handles.
- The canopy jettison firing unit sear.
- Both guillotine firing units.

### 1 General

The aircrew equipment assembly (AEA) consists of the ejection seats, the flying and safety clothing and associated equipment including oxygen connections.

## EJECTION SEAT

### 2 Ejection seat Type 4HA

(a) Two ejection seats are fitted, they are identical and can be used at all speeds and heights down to 90 kts. straight and level at ground level.

(b) The Type 4HA seat has a combined safety and parachute harness secured by a single quick release box (QRB). A back-type harness (Mk. 41) and a parachute pack of the horse-shoe type are fitted. The pack is supported on a bracket immediately below the drogue container and is held in position by two restraining straps which are attached to the headrest cushion. A personal survival pack (PSP) containing a liferaft, survival equipment and a seat cushion is housed in the seat-well. An emergency oxygen bottle is fitted to the rear of the seat-pan, to starboard of the main beams.

(c) Two leg-restraint cords, attached by bobbins and shear pins to lugs on the cockpit floor, pass up through snubbing units under the front of the seat-pan. The cords then pass through D-rings on the leg garters worn by the pilot and plug into separate sockets on the front of the seat-pan. The snubbing units allow the cords to pass freely down through them but allow movement in the opposite direction only when their release rings, one on the front of each snubbing unit, are pulled forward. These rings allow the cords to be adjusted to permit the pilot to obtain full rudder movement. During ejection the cords are pulled down through the snubbing units so that they pull the pilot's legs back from the rudder pedals and draw them together to prevent injury. A negative-G strap may be fitted. A lever on the starboard side of the seat enables the occupant to release the plugs of the leg-restraint cords from their retaining sockets and thus free them from the leg garters.

(d) The seat height may be adjusted by a lever on the starboard side of the seat. A lean-forward facility is controlled by a lever on the port side of the seat-pan.

### 3 Ejection gun and firing handles

(a) An 80ft/second ejection gun is fitted. The ejection gun is fired by pulling the face-screen firing handle or by

the seat-pan firing handle attached to the forward edge of the seat-pan between the pilot's legs. When either firing handle on either seat is operated, the canopy is jettisoned immediately by gas pressure from the canopy jettison cartridge; at the same time the sear is withdrawn from the time delay firing unit of the activated seat. The mechanism runs for one second (Post Mod. ESA 26, 0.5 second) at the end of which time the seat cartridge is fired and ejection takes place. If conditions necessitate using the seat-pan firing handle, the pilot must first press his head firmly against the headrest to minimise the risk of spinal injury on ejection. Leave the feet on the rudder pedals; drawing the feet back could lead to injury.

(b) All leads incorporate quick releases which are automatically broken on ejection.

(c) During ejection, a drogue gun on the port side of the seat is fired to extract drogues stowed in the headrest; these deploy to stabilise and decelerate the seat.

#### **4 Barostat/G-stop time delay**

(a) After ejection, at heights of 10,000 feet (or 5,000 metres, depending upon modification state) and below, a barostat causes an automatic cycle to commence. After  $1\frac{1}{4}$  secs. if the G-stop has not operated (see (b) below) the safety harness is released, as are the face-screen, firing handle and headrest pad. The drogue, which is attached to the parachute withdrawal line, is freed from the seat by the action of the barostatic time delay unit and withdraws the parachute from its pack.

(b) A G-stop is incorporated to prevent the opening of the main parachute if the speed of the seat after ejection is too high for safe deployment. The stop prevents the operation of the barostatic time delay unit until the speed of the seat has fallen to a safe figure. The seat has a ground level ejection capability provided that the aircraft's flight path is parallel to the ground and the speed is a minimum of 90 knots. If the aircraft is descending or nose-down more than the minimum altitude will be required.

## 5 Manual separation handle and guillotine unit

(a) An EMERGENCY HARNESS RELEASE handle is fitted to the port side of the seat-pan and a guillotine unit is on the port side of the drogue container. The parachute withdrawal line is routed through the guillotine unit, the sear of which is connected to the parachute pack by a static line.

(b) If manual separation from the seat is necessary, an unlocking trigger at the forward end of the EMERGENCY HARNESS RELEASE handle should be depressed and the handle pulled upwards. This action releases the parachute pack, safety harness, PSP and leg-restraint cords from the seat. By leaning forward to push the seat away, the pilot causes the static line to withdraw the sear from the guillotine firing unit. The guillotine fires and severs the parachute withdrawal line, the pilot must then pull the parachute rip-cord D-ring to make a normal parachute descent.

**WARNING:** The combined harness QRB, when fastened, secures the pilot to the seat. The box must not be operated when carrying out manual separation after ejection since this will free the pilot from both seat and parachute.

## 6 Harness restraint apron

An apron, stowed in a box on the starboard side (port side when mod 1356 or mod 1357 embodied) of the nosewheel bay when the aircraft is being flown dual, secures the instructor's seat harness, PSP and parachute pack when the aircraft is being flown solo. It does not secure the leg-restraint cords.

## ANTI-G SUIT SYSTEM

### 7 Anti-G suit system

(a) The purpose of the system is to provide air at low pressure for the pilots' anti-G suits, the connections for which are on the port side of the ejection seats.

(b) Air under pressure is stored in four air bottles, the contents of which are indicated by a pressure gauge on the starboard shelf provided the ON/OFF cock between the seats is ON. When the cock is ON and G in excess of approximately  $1\frac{1}{2}$  is applied, a spring-loaded valve operates

and allows air to pass to and inflate the anti-G suits. The amount of inflation depends on the amount of G applied.

(c) The system may be tested, with the cock ON, by pressing the ANTI-G TEST button adjacent to the ON/OFF cock or on the port shelf as gently as possible to avoid severe discomfort due to too rapid inflation. A second test button on the starboard shelf is provided for the instructor's use.

## OXYGEN SYSTEM

### 8 Oxygen system — general

Oxygen is carried in four Mk. 5D cylinders. A Mk. 17E demand regulator on the centre panel and another on the starboard shelf control the supply to each pilot. A contents gauge is above the port regulator.

### 9 Regulators

(a) Each regulator consists of an ON/OFF valve which controls the flow of oxygen, an air inlet NORMAL/100% OXYGEN switch, an emergency three-position switch and a magnetic indicator which shows black when oxygen is not being used or when electrical power is not available and a vertical white line when oxygen is being demanded. A duplicate indicator for the instructor is on the starboard instrument panel.

(b) When the ON/OFF valve is ON and the inlet switch is at NORMAL, an air/oxygen mixture is fed to the pilot's mask, up to 30,000 feet cockpit altitude at which height 100% oxygen is automatically delivered. When the inlet switch is at 100% OXYGEN, no air is added, irrespective of the height. Except in emergency, NORMAL should always be used. The emergency switch when moved right or left, admits oxygen under greater pressure.

(c) The mask may be tested before flight by firmly pressing in the emergency switch, when in the central position. Oxygen is then supplied under pressure, the more firmly the switch is pressed the greater the pressure (up to 5 times that obtained with the switch in either side position). The mask can then be adjusted until there are no leaks.

(d) To check for leaks in the system from the regulator to the mask, deflect the emergency switch; the flow magnetic indicator should show black when the breath is held.

NOTE: The maximum safe cockpit altitude with Mk. 17 regulators is 50,000 ft. If the canopy is lost, aerodynamic suck will cause the cockpit altitude to exceed the aircraft altitude by up to 8,000 ft. For this reason the maximum safe operating altitude is 42,000 ft

## **10 Emergency bottles**

(a) The emergency oxygen bottle attached to the rear of each seat functions automatically during ejection but a control knob on the starboard side of each seat-pan, when pulled up, provides a limited supply should this be necessary during a cockpit emergency.

(b) The bottle remains with the seat after separation has occurred after ejection.

## **EMERGENCY USE OF THE OXYGEN SYSTEM**

### **11 Toxic fumes**

If the cockpit becomes contaminated with toxic fumes, set the inlet switch on the regulator to 100% OXYGEN and deflect the EMERGENCY switch to either side, to prevent inward leaks on the mask. Descend to below 35,000 ft. and depressurise.

### **12 Regulator indicator failure**

(a) If the magnetic indicator ceases to operate, check that the main tube is connected correctly and switch the air inlet switch to 100% OXYGEN. If it is impossible to breathe in freely, the regulator is faulty (see para. 13).

(b) If breathing is normal, check that the pressure on the regulator gauge fluctuates with breathing and that the main oxygen contents gauge indicates that oxygen is available; if so, depress the regulator EMERGENCY switch with the switch in the central position. A supply of oxygen under increased pressure indicates that the regulator is serviceable but the indicator is defective.

### **13 Regulator failure**

If the regulator is unserviceable, as indicated by no flow,

operate the emergency bottle and descend immediately to an altitude where oxygen is not required and return to base.

#### **14 Use of the emergency bottle**

(a) If it is necessary to use the emergency oxygen bottle, pull up the emergency control on the starboard side of the seat and disconnect the mask tube from the main supply tube.

(b) The emergency supply lasts from eight to ten minutes only; the descent to 10,000 feet cockpit altitude must be completed in that time. When the bottle is empty breathing becomes difficult and the oxygen mask should be slackened or removed.

(c) On ejection, the main supply tube is automatically released and the emergency set brought into use. The duration of the set lasts until 10,000 feet is reached, separation from the seat occurs, and the emergency oxygen connection is automatically broken. After separation the pilot will be breathing air against the back pressure of the oxygen connector; to overcome this, and always when descending into water, the oxygen mask should be removed.

### **USE OF THE AIRCREW EQUIPMENT ASSEMBLY**

#### **15 Strapping-in procedure**

(a) Ensure that the safety pins are fitted through the face-screen and seat-pan firing handles. Ensure that the guillotine sear safety pin has been removed and that the parachute withdrawal line is held under the guillotine flap. If the aircraft is being flown solo ensure that the harness restraint apron is fitted to the unoccupied seat.

(b) Check that the drogue withdrawal line is routed over all other lines and is connected to the top of the drogue gun piston by shackle pin. Check that the scissor shackle is closed and flat.

(c) Check that the face-screen firing handle cable is

connected to the canopy gun sear and to the time-delay firing unit sear. Check that the ring of the seat-pan firing cable is threaded over the cable to the time delay firing unit sear.

(d) Check that the drogue gun and time delay mechanism trip rods are connected to their brackets. Check that the drogue gun safety lock pin is removed.

(e) If Mod. ES.2016 is embodied, check that the centre pin of the top latch plunger is flush with the latch housing.

(f) Grasp each lap strap and the shoulder straps in turn and tug smartly to check for security.

(g) Occupy the seat and adjust its height to position the head for optimum forward vision. Check the emergency oxygen control has not been pulled up.

(h) Pass the left-hand leg restraint cord through the right leg garter D-ring from rear to front and plug into the left-hand socket on the front of the seat-pan. Repeat for the other cord, passing the right-hand cord through the left leg garter D-ring and plugging into the right-hand socket. This will result in crossing the cords; it does not matter which cord is in front, but they must not be interlaced.

(j) Adjust the leg restraint cords to give sufficient leg movement to operate the rudder fully in both directions.

(k) Connect the PSP lowering line to the LSW ensuring that the line passes *outside* the left leg.

(l) Connect the anti-G air supply hose to the suit.

(m) Pull up the parachute back pad and adjust the height of the lumbar cushion.

◀(n) (i) If a single-lug negative-G strap is fitted, bring the strap up, ensuring that it does not pass through the seat-pan firing handle. Pass the left safety-harness lap-strap lug through the eye of the negative-G strap lug, and insert the lap-strap lug into the QRB. Fasten the right safety-harness lap-strap lug into the QRB and tighten first the lap straps, then the negative-G strap, stowing the loose end in the elastic loop provided ▶

◀ (ii) If a Y-section negative-G strap is fitted bring the strap up, ensuring that it does not pass through the ▶ seat-pan firing handle and pass the looped ends of the 'Y' section over their respective lap strap lugs. Insert the lap strap lugs into the QRB and tighten, first the lap straps, then the negative-G strap, stowing the loose end in the elastic loop provided.

◀ NOTE: The lap straps must be as tight as possible. ▶

(o) Pass the left leg loop upwards over the inside of the thigh and through the D-ring on the left lap strap (from the inside of the ring towards the outside of the leg). Bring the end of the leg loop over towards the quick release box and pass the lug of the left shoulder strap through the leg loop (from the top downwards) and insert the lug into its appropriate slot in the quick-release box. Snug the loop over the lug. Repeat these operations with the right leg loop and shoulder strap.

(p) Ensure that the shoulder straps pass under the folds of the LSW. Tighten the inner (blue) straps and then the outer (khaki) straps.

NOTE: It is undesirable to tighten these straps excessively since this action may arch the back and lead to spinal injury if ejection becomes necessary. The inner straps should not press down unduly on the shoulders but equally there should be no slack. The outer straps should be adjusted similarly to provide a comfortable fit.

(q) Operate the lean forward release. Failure of the harness to re-engage and lock back indicates that the harness is not secure.

(r) Connect the oxygen mask tube to the main oxygen supply hose and adjust the hose in its retaining strap (if provided) on the right lap strap of the harness to achieve unrestricted head movement.

(s) Connect the emergency oxygen tube to the oxygen mask tube, ensuring that it passes between the body and the main oxygen supply hose.

(t) Connect the oxygen mask tube locating chain or clip to the D-ring on the LSW.

(u) Connect the mic/tel lead.

(v) Check that the face-screen firing handle can be reached.

(w) Have the safety pins removed from the face-screen and seat-pan firing handles and placed in their respective stowages.

## **16 Normal exit procedure**

(a) Have the aircraft made 'safe for parking'.

(b) Disconnect the main and emergency oxygen supply from the oxygen mask tube.

(c) Operate the harness QRB, free the straps and return the QRB to the locked position.

(d) Disconnect the leg-restraint cords from the garters.

(e) Disconnect the PSP lowering line from the LSW.

(f) Disconnect the anti-g suit air supply hose from the suit and fit the blanking plug in the end of the hose.

(g) Disconnect the mic/tel lead.

(h) Leave the aircraft.

## **17 Forced landing**

If it has been decided not to eject or if the seat has failed to operate and manual bale-out is considered inadvisable, the following actions should be taken prior to landing.

(a) Disconnect the PSP from the LSW.

(b) Below 10,000 feet disconnect the emergency oxygen tube.

(c) Disconnect the anti-g hose.

(d) Disconnect the garter D-rings from the garters.

(e) Lean back and ensure that the safety harness is locked in the rear position. Retighten the straps as necessary.

(f) After landing release the combined harness and leave the aircraft as soon as possible. If practicable, make the aircraft 'safe for parking'.

## **18 Abandoning and ditching**

These are fully covered in Flight Reference Cards, Emergency procedures.

## PART 1

## Chapter 9 — RADIO AND RADAR

## Contents

	Para.
UHF ... ..	1
Telebriefing ... ..	2
Intercomm. A.1961 ... ..	3
DME — Rebecca Mk. 8 ... ..	4
Radar Ranging (Pre-Mod. 1321) ... ..	5
Radio Compass ... ..	6
TACAN ... ..	7
IFF/SSR ... ..	8

## 1 UHF

(a) The UHF installation comprises two sets, ARC 52 for normal use and a standby set. When ARC 52 is in use any one of 1,750 channels can be selected. The standby set provides two channels only, normally pre-tuned to 243 MHz and 243.8 MHz.

(b) The ARC 52 control unit is on the centre panel. On it are the following controls:

(i) Four tuning knobs with which any one of 1,750 frequencies may be manually selected. The knobs from left to right select hundreds, tens, units and tenths of MHz; the appropriate digits appearing in windows above the knobs.

(ii) A 20-position selector switch with which any one of 18 pre-tuned frequencies may be selected plus the guard frequency. The twentieth position selects manual tuning.

(iii) An OFF / TR / TR+G / ADF function switch. When TR is selected, only the frequency selected is in operation. With TR+G selected, the guard frequency is monitored in addition to normal communication on the channel selected. The ADF selection is not operative. At the OFF position the normal set is

switched off. In complete generator failure conditions, if the standby set only is to be used, the function switch should be set to OFF to reduce the load on the aircraft battery.

(iv) A VOLUME control is between the pre-tuned channel selector and the function selector.

(c) When SRIM 3130 is embodied, PTR 175 is fitted in lieu of ARC 52. This is a VHF/UHF set giving a choice of 3,870 communication channels, comprising 370 channels in the VHF band, 117.5 to 135.95 MHz and 3,500 channels in the UHF band, 225.0 to 399.95 MHz. Three tuning knobs on the control panel allow any one of the 3,870 channels to be manually selected. From left to right they select tens, units and increments of 0.05 MHz, the selected frequency appearing on a digital indicator above the controls. The remaining controls on the control panel are similar to those described for ARC 52.

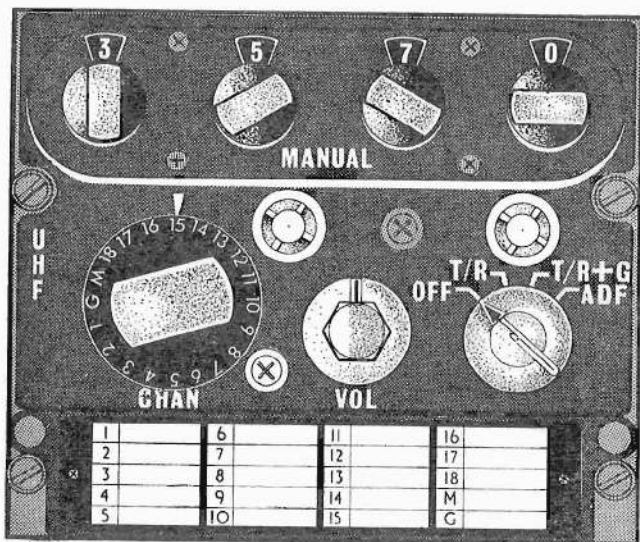

### UHF (ARC 52) Control Unit

(d) The remaining UHF controls, on a panel on the cockpit port wall are as follows:

(i) A MAIN/ST-BY/ST-BY EMERGENCY BATT switch. When MAIN is selected, the main set is in use. At

ST-BY, the standby set is brought into use. In generator failure conditions, the switch should be set to ST-BY EMERGENCY BATT allowing for the standby set to be powered by the UHF standby battery.

(ii) A GUARD/ALTVE switch is for use in selecting either the guard frequency or the alternative channel of the standby set. It should be left at GUARD; the ALTVE position is normally used for testing purposes only.

(iii) A TONE — ON/OFF switch, when set to ON, automatically modulates the main transmitter between 920 and 1120 HZ for direction finding or emergency purposes. The switch is spring-loaded to the OFF position.

(e) Two press-to-transmit switches are provided, one in each throttle lever.

## 2 Telebriefing

The landline socket is at the underside of the rear fuselage, forward of the tail bumper. When the plug is connected the UHF circuit is de-energised and an amber warning light on the port shelf indicates that telebriefing is in use. The pilot's press-to-speak pushbutton is adjacent to the warning light.

## 3 Intercomm. A.1961

(a) The intercomm. amplifier is controlled by two switches above the starboard shelf labelled ON/OFF and EMERGENCY/NORMAL.

(b) When the ON/OFF switch is set to ON the amplifier warms up and is available within 30 seconds. With the EMERGENCY/NORMAL switch at NORMAL all intercommunication is via the A.1961 amplifier. Pressing either pilot's press-to-transmit switch isolates that pilot's microphone from the circuit.

(c) If the power supply to the amplifier fails, or if switched off, setting the EMERGENCY/NORMAL switch to EMERGENCY connects the pilot's microphones to the microphone line of the UHF transmitter-receiver and the pilot's earphones to the audio-frequency output line of the transmitter-receiver, thus providing emergency intercomm. It should be noted that all conversation will be

broadcast should either press-to-transmit switch be pressed.

(d) If the amplifier fails, both intercomm. and UHF reception is lost until the amplifier is switched OFF or to EMERGENCY.

(e) A muting switch for the UHF circuit is on the central pedestal.

#### **4 DME — Rebecca Mk. 8**

(a) DME is capable of measuring ranges from selected beacons up to a maximum of 200 NM at a height of 25,000 feet or above. Range and homing information is presented on a meter on the centre instrument panel; a DME control unit is above the port shelf.

(b) The control unit has the following controls and switches:

(i) A six-position OFF/SB/200/20/BAT/BAH rotary control; this is the main function and range control. SB is the standby position, selected to allow the set to warm-up prior to use. When 200 is selected the range pointer of the range and heading meter sweeps the scale from 0 to 200 NM every 17 seconds until the equipment locks on to a beacon. Selection of 20 reduces the maximum range indication to 20 NM and the rate of sweep from 0 to 20 NM every 3 seconds. BAT and BAH are not in use.

(ii) A transmitter frequency selector, TX, which selects any one of eight interrogator channels, lettered from A to H.

(iii) A receiver selector switch, RX, which selects any one of eight receiver channels, numbered from 1 to 8.

(iv) A CODE ON/OFF switch which provides audio muting of the beacon call sign when OFF is selected.

(v) A two-position aerial switch labelled O/R and H which selects an omni-directional aerial for the reception of beacon signals when in the O/R position and port and starboard directional aerials when in the H position. The omni-directional aerial is positioned to give maximum range to the equipment.

(vi) A STROBE release button which disconnects the lock circuit and permits the equipment to recommence searching.

(c) The range and heading meter has a range pointer moving over a scale calibrated from 0 to 20, indicating range up to a maximum of 200 NM when 200 is selected on the function switch and 20 NM when 20 is selected. Heading information is provided by a vertical pointer moving relative to a fixed datum and indicating the

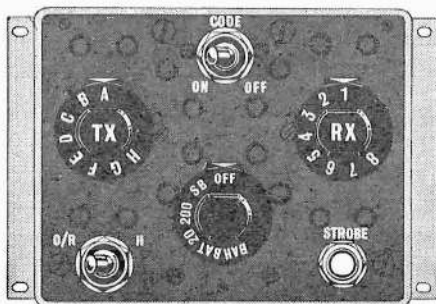

**DME Control Panel**

direction in which the aircraft must be turned to head towards the beacon. An OFF flag appears on the face of the meter when the function switch is at OFF or SB.

NOTE: When the function switch is set to SB and the aerial switch set to H, a  $\frac{1}{2}$  or 5 NM deflection is shown on the meter. The flag shows OFF and serves as a reminder that the equipment is in the SB condition.

(d) Four aerials are fitted, a transmitter aerial in the engine starter door, an omni-directional receiver aerial in the engine access door and a directional receiver aerial in each air intake.

(This equipment is replaced by TACAN when Mod. 1321 is embodied).

## **5 Radar ranging (Pre Mod.1321)**

(a) The radar ranging ON/OFF switch is on the forward end of the port shelf. An adjacent magnetic indicator shows white when radar ranging is in use and black when

not in use. The radar presentation switch is outboard of the landing gear selector buttons. Electrical power for the system is obtained from a Type 206 inverter controlled by No. 4 Type 100A inverter. (Chap. 3, para. 3 (a)).

(b) A spring-loaded TARGET REJECT—IN/OUT switch for the port GGS is on the port wall and one for the starboard GGS is on the centre panel.

(c) A range proximity indicator light and a lock-on light are on the right hand camera recorder bracket on each GGS.

## **6 Radio compass**

(a) When Mod. 995 is embodied a sub-miniature radio-compass is fitted. The radio compass provides automatic direction finding and normal MF radio reception. The bearing indicator is on the central instrument panel and the system is controlled by a control unit and a UHF/MIX switch, also on the central instrument panel.

(b) The control unit has the following facilities:

(i) An ON/Off switch which controls the DC supply to the instrument.

(ii) An ADF/REC switch which controls the RF and IF amplifiers. When switched to ADF, automatic direction finding is in operation. When set to REC, the automatic direction finding is inoperative and the unit functions as a conventional MF receiver.

(iii) A frequency band three-position lever-operated rotary selector switch.

(iv) A TUNING control handle and TUNE indicator. Indication of signal frequency is given by the scale on the tuning dial drum and signal strength is indicated by a clockwise deflection of the tuning indicator needle.

(v) A GAIN control to regulate the output of the received signals at the pilot's headset.

(vi) A beat frequency oscillator valve CW/RT switch. When set to CW, keyed continuous wave stations are received; when set to RT, normal RT signals are received.

(vii) A panel illumination DIM PUSH switch to control the brightness of panel and tuning scale illumination.

(c) The UHF/MIX switch is used to control the audio-output of the compass to the pilot's headset. With the switch at MIX, both radio compass and UHF signals are received. When set to UHF, only UHF is received

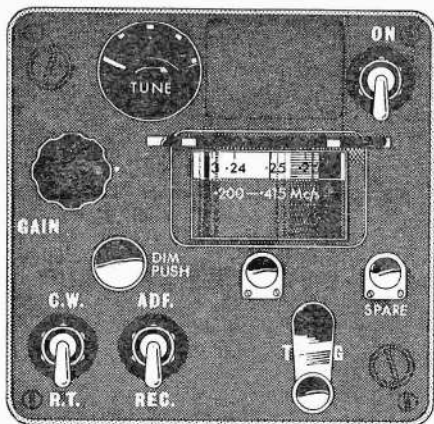

**ADF Control Panel**

## 7 TACAN

(a) When Mod. 1321 is embodied a TACAN navigation aid is installed in place of DME and radio compass. TACAN is an airborne navigational aid used with ground or shipborne beacons to provide the pilot with a continuous indication of bearing and distance from a selected beacon. This information is displayed on an indicator on the centre instrument panel by means of a pointer against a compass scale for bearing and a three-digit counter unit for range. The installation is controlled by a control unit on the port side of the centre panel.

(b) The control unit has the following switches and indicator:

<i>Control/Marking</i>	<i>Function</i>
Two-position switch — ON/OFF	Controls the power supplies to the system
Two-position switch — BRG/DIST BRG	BRG — Selects bearing information only for display (inoperative on the T Mk. 7A). DIST BRG — Selects both bearing and range information for display.
Four pushbuttons and channel indicator	Each time a button is pressed the beacon channel is changed and the indicator number changes by one digit. The two buttons above the indicator increase units and tens by one and the lower pair decrease the numbers in a similar manner
Rotary control — VOL	Regulates the level of the audio signals to the crew's headsets

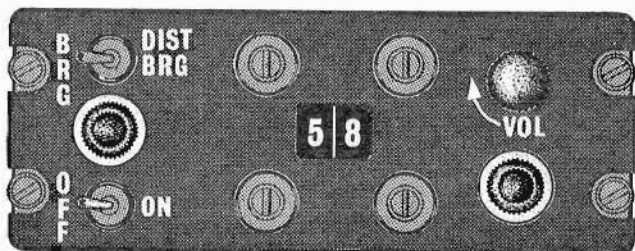

**TACAN Control Unit**

(c) Power supplies for the system are provided by the DC busbar and the output of a Type 108 inverter. A magnetic FAILURE indicator above the TACAN indicator shows black when power supplies are available (when the aircraft is airborne) and white when there is a power supply failure. If a failure occurs the RESET button adjacent to the FAILURE indicator should be operated in an attempt to restart the inverter. After landing, operation of the RESET button cuts out the TACAN inverter before the generators come 'off line' thus preventing an unnecessary drain on the aircraft batteries.

(d) Signals from Tacan are passed to the crew's headsets via a beacon junction box on the cockpit port wall. A rotary control on this junction box has three positions, RT/MIX/BEAC. When RT is selected, only signals from the UHF set in use are heard. The MIX position allows both UHF and Tacan signals to pass to the headsets and with selection of BEAC, only TACAN signals can be heard.

## 8 IFF/SSR

(a) When Mod. 1357 or Mod. 1356 (Post Mod. 1321) is embodied, IFF/SSR is fitted. IFF/SSR equipment provides automatic identification of the aircraft by transmitting coded pulse replies in answer to interrogation signals transmitted in various modes by military radar (IFF) stations or by civil secondary surveillance radar (SSR) stations.

(b) A control unit below the starboard instrument panel or in place of the port GGS (Mod. 1356) is used to control the system and has the following controls and indicator:

<i>Control/Marking</i>	<i>Function</i>
<p>Five-position rotary master switch:  <b>OFF/SBY/LOW/NORM/EMGY</b>  <b>PUSH</b></p>	<p><b>OFF:</b> Equipment inoperative.</p> <p><b>SBY:</b> Power to equipment. After 50 seconds warm-up, equipment is ready for full use.</p> <p><b>LOW:</b> Equipment functioning with reduced sensitivity. Use only when requested by ground station, to reduce clutter.</p> <p><b>NORM:</b> Equipment functioning fully.</p> <p><b>EMGY PUSH:</b> Press and turn switch to set this position. Emergency replies will be made to interrogation (Modes 1, 2, 3A or B only) irrespective of mode selection.</p>
<p>Four on/off Mode selector switches (up for on)  <b>MODE/1, 2, C and D</b></p>	<p>1: Transponder will accept Mode 1 interrogation and will reply using selected Mode 1 code.</p> <p>2: Transponder will accept Mode 2 interrogation and will reply using fixed Mode 2 code.</p> <p>C: Transponder will accept Mode C interrogation and in reply will transmit aircraft altitude information using code determined by separate coding unit (not yet fitted).</p> <p>D: Not yet in use.</p>

<i>Control/Marking</i>	<i>Function</i>
<p>Three-position rotary Mode selector: 3A/OFF/B</p>	<p>OFF: Transponder will not accept or reply to Mode 3A or Mode B interrogation.</p> <p>3A: Transponder will accept Mode 3A interrogation and will reply using selected Mode 3 code.</p> <p>B: Transponder will accept Mode B interrogation and will reply using selected Mode 3 code.</p>
<p>Code number selector for Mode 1 and Mode 3A or B transponder reply: MODE 1 (four digit selectors and digit indicators) MODE 3 (four digit selectors and digit indicators)</p>	<p>Each set of four selectors used to set appropriate code number. Indicators show 0000 to 7777 allowing 4,096 possible codes to be set.</p> <p>Use MODE 1 selectors for coding Mode 1 replies.</p> <p>Use MODE 3 selectors for coding Mode 3A or B replies.</p> <p>NOTE: Mode 2 reply codes are preset at the transponder before flight and are not accessible from the cockpit.</p>
<p>Two-position emergency coding switch: CIVIL/MIL</p>	<p>Used only in conjunction with EMGY PUSH selection to establish emergency reply code.</p> <p>MIL: Normal position. Codes selected on control unit or transponder (Military codes 1, 2, or 3).</p> <p>CIVIL: Code 7700 automatically selected for emergency reply transmission to civil Mode (A or B) interrogation.</p>

<i>Control/Marking</i>	<i>Function</i>
Two-position switch (spring-loaded off): I/P	When operated momentarily (as requested by the ground station) then released, an Identification Pulse is automatically transmitted for twenty seconds.
Self test push switch incorporating a double filament green light: TEST	When pressed, with equipment switched on, carries out check of receiver sensitivity, transmitter power output and Mode serviceability. Set NORM, press TEST button (after 50 secs. warm-up). If check satisfactory TEST light will illuminate. Unsatisfactory check is indicated by the failure of the TEST light to illuminate. (The TEST light filaments can be checked by pressing the TEST switch while the equipment is switched OFF, but with the battery master switch on).

(c) The operating Modes and the codes to be used are normally established before flight, but the ground radar station controlling the flight can, using voice communication, request particular Modes and codes to be selected as required. Codes 7600 and 7700 are selected only in emergency situations to give the ground station a special read-out alarm signal.

- (i) Code 7600 — to indicate that the aircraft has suffered total voice communication failure.
- (ii) Code 7700 — to indicate that a special emergency exists in the aircraft.

(These Codes are used in conjunction with EMGY PUSH selection).

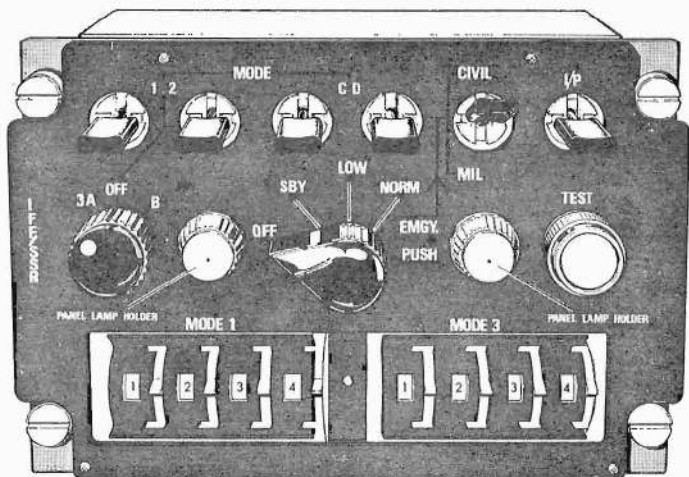

### IFF/SSR Control Panel

(d) An amber IFF FAIL warning light on a panel adjacent to the control unit incorporates a press-to-test facility for checking the filaments of both the IFF FAIL warning light and the TEST light on the control unit. The IFF FAIL warning light illuminates to give warning of any of the following:

- (i) Master switch set to SBY and transponder being interrogated but unable to reply (flashing light).
- (ii) Transponder unserviceable.
- (iii) Self test is not satisfactory.

(e) A switch on the same panel marked BRIGHT/OFF/DIM controls the lighting of the control unit.

**RESTRICTED**

## PART 1

## Chapter 10 — ARMAMENT AND CAMERA INSTALLATION

### Contents

	Para.
Gyro gunsights Mk. 8 ... ..	1
G.90 and recorder cameras ... ..	2
Gun firing ... ..	3
RP/bomb release ... ..	4
Pylon stores jettisoning ... ..	5
'Clear aircraft' switch bar ... ..	6
Armament safety plug ... ..	7

### 1 Gyro gunsights Mk. 8

NOTE: When Mod. 1356 is embodied the port gunsight is removed.

(a) Each GGS is housed in a fixed mounting one above each instrument panel. The GGS ON/OFF switch is on the right of the port sight.

(b) Each sight automatically provides for both manual and radar ranging. Altitude and ballistics units automatically compensate for the time of flight and gravity drop of the particular ammunition in use. The altitude unit is fully automatic but the ballistics unit must be pre-set for the particular ammunition before flight.

(c) A control unit on the port shelf has three controls which are used to adjust the sights, these are:

<i>Control/Marking</i>	<i>Function</i>
<p>Five-position rotary selector — G1/G2/B/RP1/RP2</p>	<p>G1 — Air-to-air attacks with guns against high speed targets. Also suitable for ground attack with guns.</p> <p>G2 — Air-to-air attacks with guns against low speed targets. Also suitable for use against banner targets.</p> <p>B — Ground attacks with bombs.</p> <p>RP1 — Ground attacks with high velocity RPs, e.g. SNEB 68 mm RPs fired from MATRA launchers.</p> <p>RP2 — Ground attacks with low velocity RPs, e.g. 3" RPs.</p>
<p>Rotary control — DIM/BRIGHT</p>	<p>Controls the brilliance of the pupil's GGS presentation</p>
<p>Bombs servo potentiometer, rotary control beneath VOLTS ADJUST PUPIL. No marking</p>	<p>With B selected on the main selector, the manual ranging circuit is isolated. The pilot can set the diameter of the gyro graticule by operating the bombs servo potentiometer and observing the external range scale until a range reading appropriate to the required depression angle is obtained. Inadvertent operation of the throttle twist grip during normal throttle handling will not affect the sight presentation</p>

NOTE: Pre Mod. 1286, no bombs servo potentiometer is fitted and the selector gives a selection of G (gyro), F & G (fixed and gyro), F (fixed), MRP (medium RP) and SRP (steep RP).

(d) A second control unit on the starboard shelf has the following controls for the instructor's use:

<i>Control/Marking</i>	<i>Function</i>
Two-position rotary selector — INSTR/PUPIL	Gives manual ranging authority to the specified pilot's twist grip.
Rotary control — DIM/BRIGHT	Controls the brilliance of the instructor's sight presentation.
Pushbutton — TEST	With the GGS — ON/OFF switch selected ON, the push-button is depressed to test the serviceability of the radar ranging indicator lights.
Push-pull control — IN DAY/OUT NIGHT	Used to adjust the brilliance of the radar ranging indicator lights for day or night use.

(e) The sighting index for all gun and RP modes is the centre spot of the gyro graticule. The sighting index for the bomb mode is the lower point of the bottom diamond.

## 2 G90 and recorder cameras

(a) The cine and recorder cameras are operated automatically whenever the gun or camera operating push-button on either control column is energised, with the camera master switch ON.

(b) In the RP mode, when the camera operating push-button is depressed, the cameras operate and the GGS gyro is uncaged. When the bombs/RP release pushbutton is depressed the gyro is re-caged and the cameras will stop after a brief overrun period.

(c) When Mod. 1338 is embodied, a delay is introduced which re-cages the gyro and stops the cameras one second after the bombs/RP release has been depressed. This assists the pilot to continue tracking throughout a ripple firing sequence and effectively increases the overrun period for both cameras.

(d) The camera master switch is on the switch panel below the port instrument panel. The aperture switch is on the starboard side of the centre instrument panel.

### **3 Gun firing**

(a) A gun-firing trigger is on the forward face of each control column handgrip. The circuit is automatically isolated when the landing gear is locked down. A BUTT TEST switch is on the starboard shelf. It is operated by a special key and provides an over-ride of the automatic isolation of the gun-firing circuit.

(b) The gun-firing current is provided by a capacitor discharge unit, which is operative only when either gun trigger safety flap is raised and the gun-firing circuit is "live".

NOTE: When Mod. 1321 is embodied the gun and the G90 camera are removed.

### **4 RP/bomb release**

#### *(a) RP firing*

When the BOMBS/RP switch on the armament control panel is set to RP and the RIPPLE/NORMAL and SELECTOR switches are set as required, RP's are fired by pressing the bomb/RP release pushbutton beneath a safety flap on the control column. No jettison facilities are available.

(b) *Bomb controls*

Bomb controls are on the armament control panel; a FUZING switch and a BOMBS/RP switch are provided.

**5 Pylon stores jettisoning**

(a) *Inboard store jettison*

When the bomb fuzing switch is set to OFF, all inboard stores are jettisoned by pressing the INBD STORES JETTISON pushbutton.

(b) *Outboard store jettison*

When the OUTB STORES JETTISON pushbutton is pressed, outboard stores are jettisoned.

**6 'Clear aircraft' switch bar**

When the bomb fuzing switch is OFF, all stores carried on the four pylons may be simultaneously jettisoned by pulling down the CLEAR A/C switch bar on the armament panel.

**7 Armament safety plug**

A safety plug is fitted behind a panel in the port stub wing. When disconnected, the plug renders inoperative the following services:

Gun and RP firing

Bomb release

Inboard stores jettison

Camera operation

Normal landing gear retraction. (The emergency up-on-the-ground circuit is not affected.)

**RESTRICTED**

This file was downloaded  
from the RTFM Library.

Link: [www.scottbouch.com/rtfm](http://www.scottbouch.com/rtfm)

Please see site for usage terms,  
and more aircraft documents.

