

SERVICES—FUEL FILTER DE-ICING SYSTEM

Ref. No.	Part No.	Description	No. Off	Material Specification	M.R. Class of Store	Plate No.
	B.219909	FUEL FILTER DE-ICING SYSTEM, CENTRE FUSELAGE, ASSEMBLY	—	—		
27BA/8826	Auto Prod. A.V.A.638	Cap , blanking, medium and high pressure for union half Coupling	1	—	C.	
	F.215030	Cleat , on blanking plate, aft frame 37, starboard ...	2	LFS.21		
	Std.2046/17/26	Clip , sleeved (AS.770/41)	3	—		
	Std.851/44	Clip , $\frac{7}{16}$ " wide x 22 s.w.g. x 4-4" long	1	DTD.610		4
27BA/8759	Auto Prods. A.V.A.57B	Coupling , half, high pressure union half	—	—	B.	
27BA/8766	Auto. Prod. A.V.A.62B	Nut , union, medium and high pressure (light alloy)	1	—	C.	
8795	B.211463/4	Pipe , coupling to non-return valve	1	T.55	C.	NA.1
9016	B.211463/5	Pipe , non-return valve to fuel delivery pipe connection	1	T.55	C.	NA.1
9019	B.211463/9	Pipe , coupling, to solenoid valve	1	T.55	C.	NA.1
9021	B.211463/11	Pipe , solenoid, to coupling	1	T.55	C.	NA.1
6253	A.205848	Shield , heat	2	S.84	C.	NA.1
27V/4814	Teddington Controls FAW/A/325	Solenoid	1	—	A.	
6260	F.204903	Union , jet	1	—	B.	NA.1
27F/2661	Saunders N.1002	Valve , non-return	1	—	A.	
	C.220703	FUEL FILTER DE-ICING SYSTEM, REAR FUSELAGE, ASSEMBLY	—	—		
27BA/8832	Auto Prods. A.V.A.64-7B	Cap , blanking, medium and high pressure for flange or stud half	2	—	C.	
27BA/8775	Auto Prods. A.V.A.64-7C	Cap , blanking, medium and high pressure for flange or stud half	1	—	C.	
	Std.2045/15/26	Clip , sleeved	3	—		4
	Std.2045/17/26	Clip , sleeved	4	—		4
	Std.2045/21/24	Clip , sleeved	4	—		4
27BA/11760	Auto Prod. A.V.A.1150B	Coupling , half, medium pressure, flange half (Mod. 1078)	2	—	B.	
27BA/11415	Auto Prod. A.V.A.1150C	Coupling , half, medium pressure, flange half (Mod. 1078)	1	—	B.	
	Std.1231/12	Lug , locking	3	S.3		4
9024	A.211091	Pipe , branch	1	T.55	C.	NA.1
8792	B.211463/1	Pipe , overflow, tank to coupling	1	T.55	C.	NA.1
8793	B.211463/2	Pipe , pump drain to atmosphere	1	T.55	C.	NA.1
8794	B.211463/3	Pipe , pump to coupling	1	T.55	C.	NA.1
9017	B.211463/6	Pipe , charging coupling to adaptor	1	T.55	C.	NA.1
9018	B.211463/7	Pipe , vent, connection to atmosphere	1	T.55	C.	NA.1
9020	B.211463/10	Pipe , pump to filter	1	T.55	C.	NA.1
10763	F.250992	Pipe , link (Mod. 1044)	1	T.55	C.	
5UE/6294	Plessey FP.3	Pump , Mk. 9	1	—	A.	
6254	B.205142	Strap , tank, mounting, group	2	—	C.	NA.1
	B.205142/1	Strap , short	1	DTD.166		
	B.205142/2	Strap , long	1	DTD.166		
	AS.1892	Trunnion	1	—		
	AS.1894	Trunnion	1	—		
9025	C.210761	Tank , alcohol, group	1	—	A.	NA.1
6256	A.205045	Adaptor	1	—	C.	NA.1

SERVICES—FUEL FILTER DE-ICING SYSTEM

Ref. No.	Part No.	Description	No. Off	Material Specification	M.R. Class of Store	Plate No.
SUMMARY OF STOCK ITEMS						
28D/13868	A25.1.B	Bolt, 4 B.A.
28D/1010658	A25.1.B	Bolt, 4 B.A.
28D/1008149	A25.2.B	Bolt, 4 B.A.
28D/9436920	A25.1.C	Bolt, 2 B.A.
28D/1011238	A25.3.E	Bolt, 1/4" B.S.F.
28D/1010031	A25.8.E	Bolt, 1/4" B.S.F.
28D/8300	AS.1242.1.B	Bolt, 4 B.A.
28M/10290	AGS.2001.E.1	Nut, 1/4" B.S.F.
28M/10327	AGS.2002.B.1	Nut, 4 B.A.
28M/10330	AGS.2002.E.1	Nut, 1/4" B.S.F.
28R/7973	AGS.165.B	Ring, lock
28S/1011481	A31.C.48	Screw
28W/9419474	SP.15.B	Washer, 4 B.A....
28W/9419475	SP.15.C	Washer, 2 B.A....
28W/9419405	SP.15.E	Washer, 1/4" dia.
28F/8215	AGS.1138.B	Washer
28F/9649	AGS.1138.C	Washer
28F/9654	AGS.1138.G	Washer

RESTRICTED

Ref. No.	Part No.	Description					No. Off	Material Specification	M.R. Class of Store	Plate No.
		1	2	3	4	5				

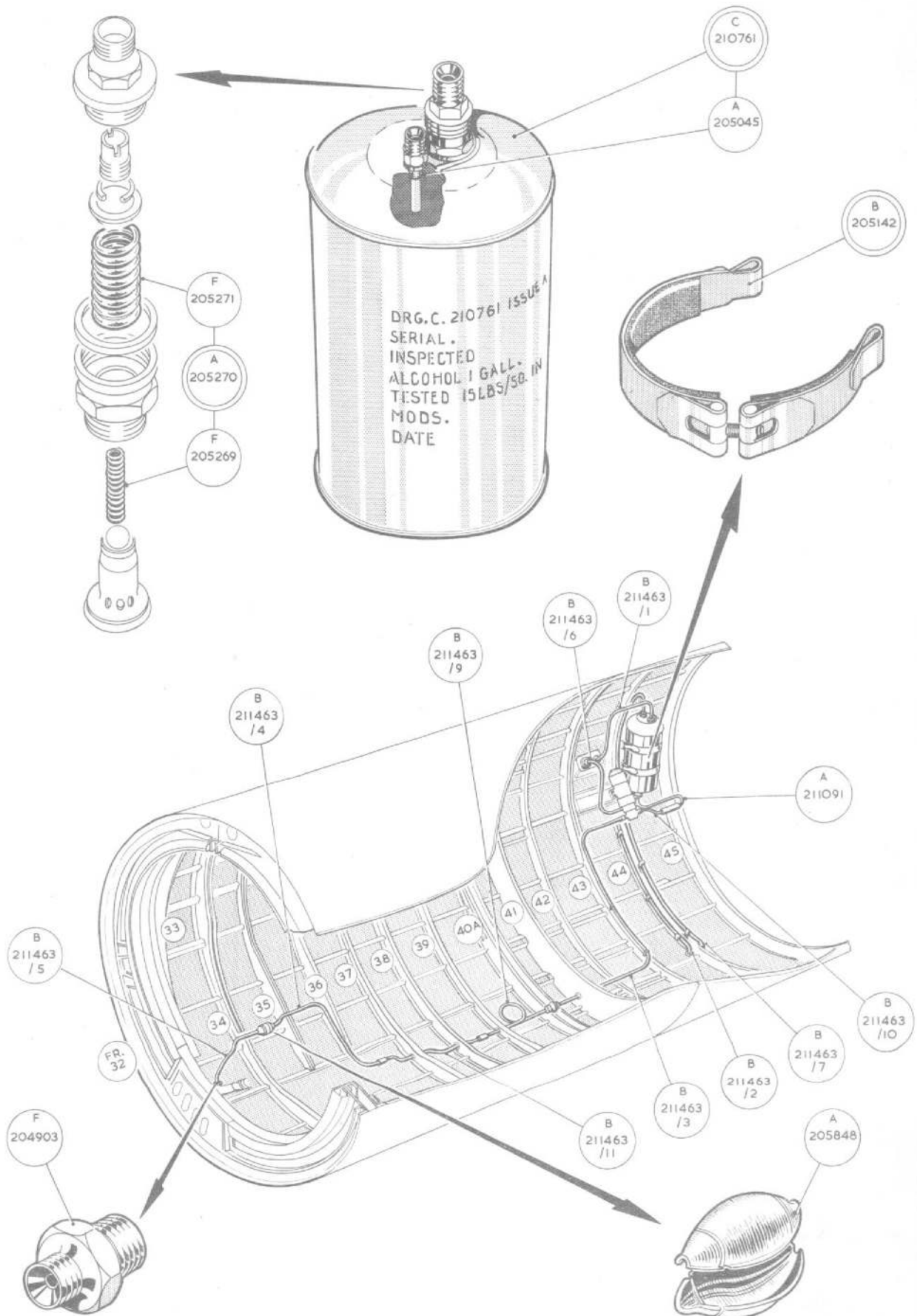

FUEL FILTER DE-ICING SYSTEM

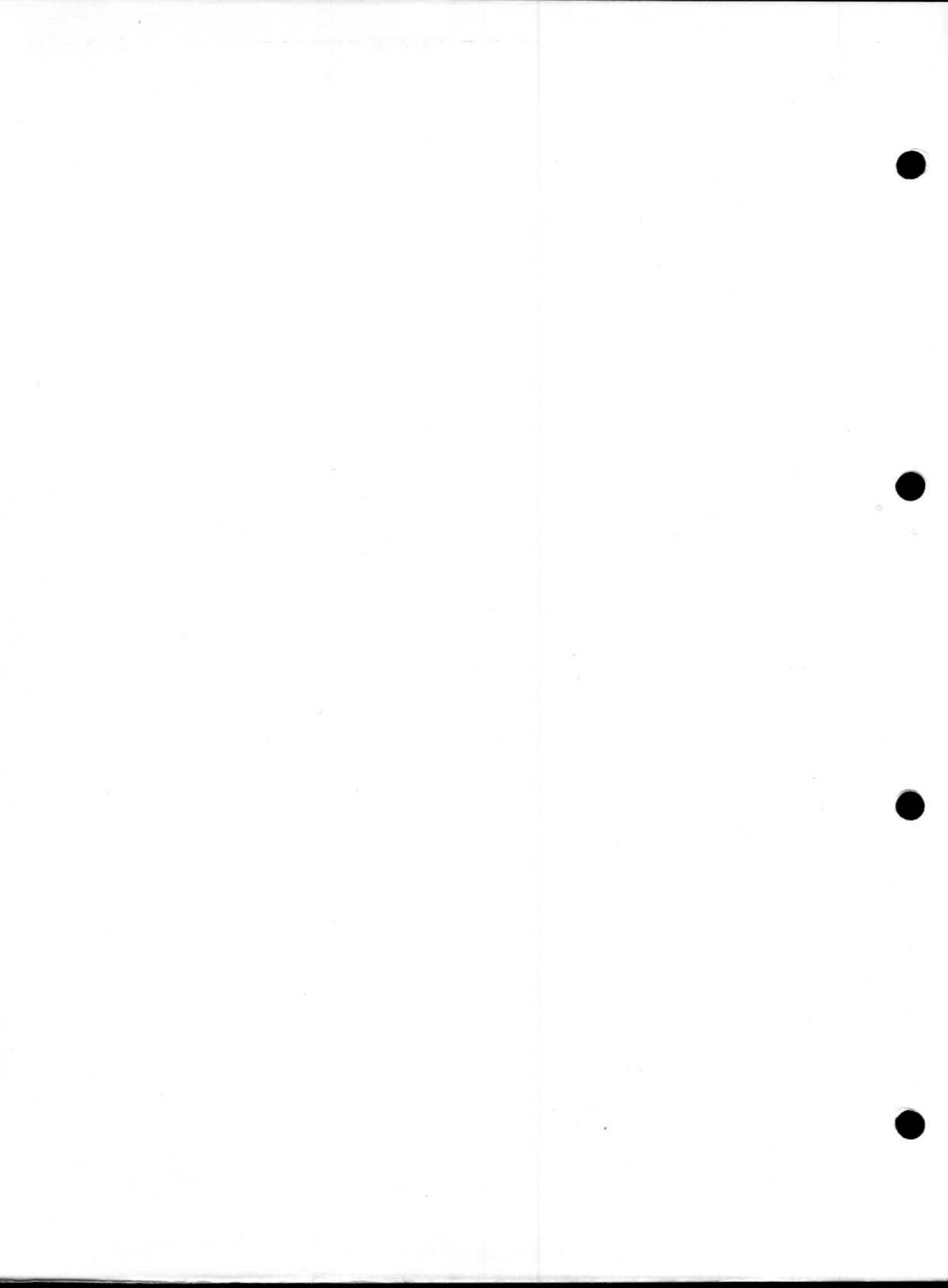

This file was downloaded
from the RTFM Library.
Link: www.scottbouch.com/rtfm

Please see site for usage terms,
and more aircraft documents.

