

RESTRICTED

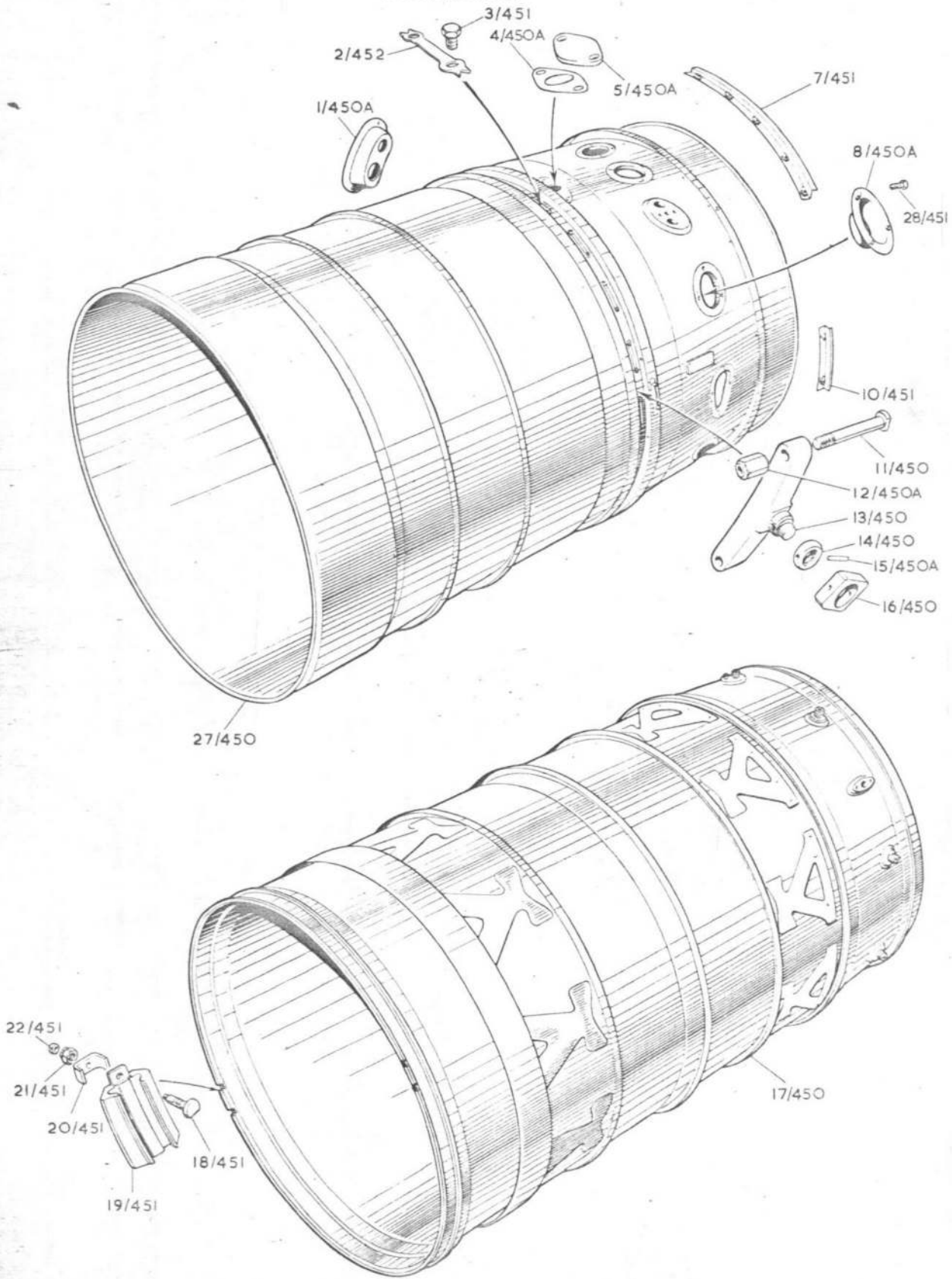

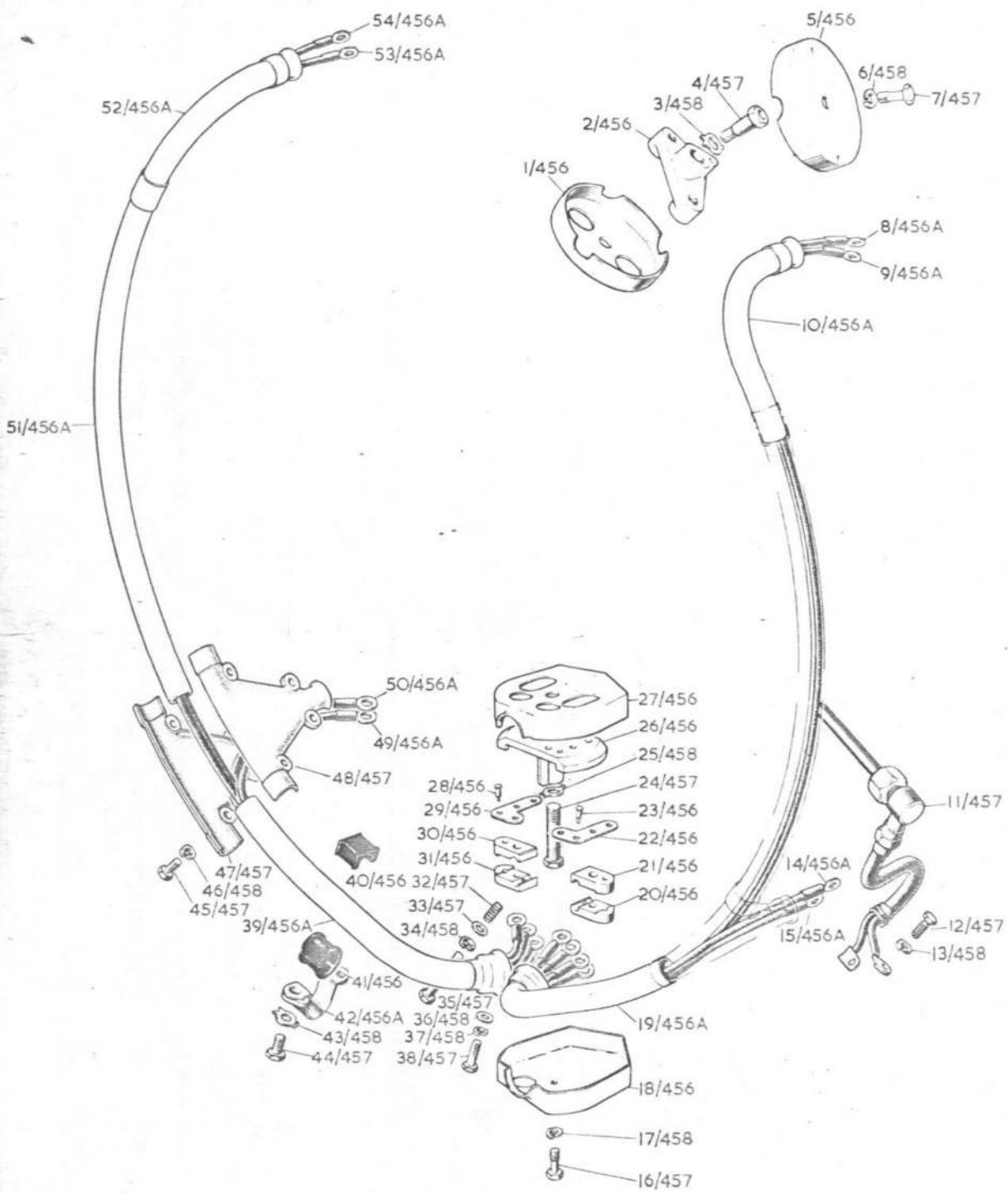

RESTRICTED

Avon 208

INSTALLATION FITTINGS

Page 450

A.L.7

REF. No.	PART No.						DESCRIPTION	No. OFF	MATL. SPEC.	M.R. C.L. of ST.	PL. & ILL. No.
		1	2	3	4	5					
-	BA85378						JET PIPE				
36VV/11820	JP122						JET PIPE - ASSEMBLY	1	-	P	-
36VV/4732	BK7182						Bearing, spherical, mounting bracket	2	Al B	P	80/1
36VV/4730	BA40334						Block, mounting bracket	2	St St1	C	80/1
36VV/14167	BA68785						Bolt, .250" x 1.750" long, mounting bracket	4	St St1	C	80/1
36VV/14525	BA68784						Bracket, mounting jet pipe	2	St St1	C	80/1
36VV/16665	BR7803*						CASING, INNER, JET PIPE - ASSEMBLY (MOD 87) (PRE-MOD 226)	1	-	P	-
36VV/19341	BR35683*						CASING, INNER, JET PIPE - ASSEMBLY (MOD 226) (PRE-MOD 246)	1	-	P	-
-	BR42743*						CASING, INNER, JET PIPE - ASSEMBLY (MOD 246) (PRE-MOD 453)	1	-	P	-
-	BR65792A						CASING, INNER, JET PIPE - ASSEMBLY	1	-	P	80/1
36VV/14283	BA95409*						CASING, OUTER, JET PIPE - ASSEMBLY (PRE-MOD 1960)	1	-	P	-
36VV/19322	BR17214*						CASING, OUTER, JET PIPE - ASSEMBLY (MOD 196) (PRE-MOD 200)	1	-	P	-
36VV/19338	BR29584*						CASING, OUTER, JET PIPE - ASSEMBLY (MOD 200) (PRE-MOD 230)	1	-	P	-
36VV/22654	BR38444*						CASING, OUTER, JET PIPE - ASSEMBLY (MOD 230) (PRE-MOD 246)	1	-	P	-
-	BR42744						CASING, OUTER, JET PIPE - ASSEMBLY (MOD 246)	1	-	P	80/2
36VV/14185	BA83788*						CUP, SEALING, THERMOCOUPLE AND PITOT CONNECTIONS - ASSEMBLY (PRE-MOD 196)	1	-	P	-
36VV/19316	BR15643*						CUP, SEALING, THERMOCOUPLE AND PITOT CONNECTIONS - ASSEMBLY (MOD 196) (PRE-MOD 246)	1	-	P	-
36VV/14186	BA83790*						CUP, SEALING, THERMOCOUPLE AND PITOT CONNECTIONS - ASSEMBLY (PRE-MOD 196)	1	-	P	-
36VV/19137	BR15644*						CUP, SEALING, THERMOCOUPLE AND PITOT CONNECTIONS - ASSEMBLY (MOD 196) (PRE-MOD 246)	1	-	P	-
36VV/14187	BA83792*						CUP, SEALING, PITOT CONNECTION - ASSEMBLY (PRE-MOD 196)	1	-	P	-
36VV/19318	BR15645*						CUP, SEALING, PITOT CONNECTION - ASSEMBLY (MOD 196) (PRE-MOD 246)	1	-	P	-

RESTRICTED

S.O.S.P. 104A

RESTRICTED

Avon 208

INSTALLATION FITTINGS - CONTINUED

Page 450A

A.L. 15

REF. No.	PART No.						DESCRIPTION	No. OFF	MATL. SPEC.	M.R. C.L. of ST.	PL. & ILL. No.
		1	2	3	4	5					
36VV/14188	BR83794A*						CUP, SEALING, THERMOCOUPLE CONNECTION - ASSEMBLY (PRE MOD 196)	5	-	P	-
36VV/19319	BR15646A						CUP, SEALING, THERMOCOUPLE, CONNECTION - ASSEMBLY (MOD 196)	5	-	P	80/8
36VV/19319	BR15646A						CUP, SEALING, THERMOCOUPLE, CONNECTION - ASSEMBLY (MOD 246)	8	-	P	80/8
36VV/14189	BA83796A*						CUP, SEALING, THERMOCOUPLE AND STATIC CONNECTIONS - ASSEMBLY (PRE-MOD 196)	1	-	P	-
36VV/19320	BR15647A*						CUP, SEALING, THERMOCOUPLE AND STATIC CONNECTIONS - ASSEMBLY (MOD 196) (PRE-MOD 246)	1	-	P	-
36VV/14189	BA83796A						CUP, SEALING, THERMOCOUPLE AND STATIC CONNECTIONS - ASSEMBLY	1	-	P	80/1
36VV/4914	BA45634						Jointing, drain connection blanking plate	1	-	C	80/4
36VV/14168	BA68786						Nut, .252" mounting bracket bolt	4	NS	C	80/12
36VV/4734	BK6522						Pin, mounting, bracket spherical bearing locating	2	St Stl	C	80/15
-	-						Pin, split, .062" x .750" long, jet pipe to exhaust unit keep plate bolt nut (Pre-Mod 3536) (Mod 3536)	2	St Stl	C	1/16
28P/12431	KB6853*						Plate, blanking, drain connection	1	St Stl	C	80/5
28P/9486478	SP90/C5						Plate, blanking, pitot connection (Pre-Mod 246)	3	St Stl	C	-
36VV/14169	BA68787										
36VV/18000	BK3346*										

RESTRICTED

RESTRICTED

Avon 208

INSTALLATION FITTINGS - CONTINUED

Page 451

A, L, 24

REF. No.	PART No.						DESCRIPTION	No. OFF	MATL. SPEC.	M.R. C.L. of ST.	PL. & ILL. No.
		1	2	3	4	5					
36VV/12003	BA66372*						JET PIPE - CONTINUED	2	-	C	-
							PLATE, KEEP, JET PIPE TO EXHAUST UNIT - ASSEMBLY (PRE-MOD 453)				
-	BR42127A						PLATE, KEEP, JET PIPE TO EXHAUST UNIT - ASSEMBLY (MOD 453)	2	-	C	- 80/19
-	BA39907						Bolt, .3125" x 1.300" long, keep plate and stirrup securing	2	NS	-	80/18
-	BA39908						Collar	2	St Stl	-	80/22
-	BA37831						Nut, castellated, keep plate and stirrup bolt (Pre-Mod 221)	2	St Stl	-	-
36VV/19463	KB18258						(Mod 221)	2	St Stl	-	80/21
36HH/6197	KB3852						Pin, taper collar retaining	2	St Stl	C	1/13
-	BR42128						Plate, keep	2	C263	-	80/19
-	BA51738						Stirrup	2	St Stl	-	80/20
36VV/6118121	KB5826*						PLUG, SEALING, STATIC PRESSURE CONNECTIONS - ASSEMBLY (PRE-MOD 246)	2	-	C	1/31
37L/1725	KB5226						Nut	2	St Stl	C	-
-	-						Pin, split, .062" x .500" long (Pre-Mod 3536)	2	St Stl	C	-
28P/12587	KB6851*						(Pre-Mod 3536)				
28P/1021104	SP90/C3						(Mod 3536)				
37L/1724	KB5801						Plug	2	St Stl	C	-
36VV/18079	BK3864						Screw, .250" x .425" long Thermocouple cable retaining strips- *Sealing cups (Pre-Mod 196)	-	NS	C	80/3
							Outer to inner casings	14			
							Drain connection blanking plate	31			
							plate	34			
							250" sealing cups (Mod 196)(Pre-Mod 246) (Mod 246)	4			
36VV/19315	BR3781						Screw, 250" x .300" long, pitot connection blanking plate (Pre-Mod 146)	-	NS	C	80/28
								31			
								24			
36VV/14441	BA69628*						Screw, 250" x .300" long, pitot connection blanking plate (Pre-Mod 146)	6	St Stl	C	-
36VV/14183	BA83784						STRIP, SHORT, THERMOCOUPLE CABLE RETAINING - ASSEMBLY	2	-	C	80/10
36VV/14184	BA83786						STRIP, LONG, THERMOCOUPLE CABLE RETAINING - ASSEMBLY	2	-	C	80/7
36VV/6118128	BK3345*						Washer, joint, pitot connections (Pre-Mod 246)	3	Copper	C	-

RESTRICTED

JET PIPE - CONTINUED

17672	KB.7106	Washer, tab, .255" i/dia. x .032" thick,	-	St.Stl	C	1/10
		*Pitot connection blanking plate securing screws (Pre-Mod.246)	6			
		Jet pipe mounting bracket securing screws	4			
		Thermocouple cable retaining strips securing screws	14			
		Drain connection blanking plate securing screws	4			
		Sealing cups screws *(Pre-Mod.246)	31			
		(Mod.246)	24			
14375	D.45942	Washer, tab, double, outer to inner casings securing screws	17	St.Stl	C	80/2

RESTRICTED

Avon 208

PL-8  
LL N.

Pages 453,454 and 455  
not issued

RESTRICTED

S.O.S.P.104

RESTRICTED

Avon 208

INSTALLATION FITTINGS

Page 456

A, L, 7

REF. No.	PART No.						DESCRIPTION	No. OFF	MATL. SPEC.	M.R. C.L. of ST.	PL. ILL. N.
		1	2	3	4	5					
						THERMOCOUPLE HARNESS					
36VV/12138	BA76679					BLOCK, CLAMPING - ASSEMBLY	1	-	P	-	
36VV/12139	BA76680					Block, clamping	1	Alumel	P	81/	
36VV/12141	BA76682					Pin, block locating	1	St Stl	C	81/	
36VV/12140	BA76681					Strip, contact	1	Alumel	C	81/	
36VV/12139	BA76680					BLOCK, clamping	1	Alumel	P	81/	
36VV/12142	BA76683					BLOCK, CLAMPING - ASSEMBLY	1	-	P	-	
36VV/12143	BA76684					Block, clamping	1	CHROML	P	81/	
36VV/12141	BA76682					Pin, block locating	1	St Stl	C	81/	
36VV/12144	BA76685					Strip, contact	1	CGROML	C	81/	
36VV/12143	BA76684					BLOCK, clamping	1	CHROML	P	81/	
36VV/17889	BR22358					BLOCK, terminal, main junction box (Mod 184)	1	-	P	81/	
36VV/12169	BA80089					BLOCK, terminal, thermocouple junction box	1	-	P	81/	
36VV/12162	BA76675					BOX, junction, main, bottom half	1	St Stl	P	81/	
36VV/12163	BA80113					BOX, junction, main, top half	1	St Stl	P	81/	
36VV/12177	BA80108					BOX, junction, thermocouple, bottom half	4	St Stl	P	81/	
36VV/12178	BA80109					BOX, junction, thermocouple, top half	4	St Stl	P	81/	
36VV/19323	BR17218					BUSH, split, pipe clip T/C harness (Mod 196)	8	-	-	81/	
36VV/19314	BA81523*					BUSH, split, pipe clip T/C harness (Mod 196)	8	Fluon	C	-	
36VV/23508	BR51817					BUSH, thermocouple harness pipe clip (Mod 291)	4	Fluon	C	81/	
36VV/14201	BA86822*					CABLE, THERMOCOUPLE JUNCTION BOX TO MAIN JUNCTION BOX - ASSEMBLY (PRE-MOD 196)	1	-	P	-	

RESTRICTED

S.O.S.P. 104A

A.L. 5

M.R. PL  
CE of ILL  
STTHERMOCOUPLE HARNESS -  
CONTINUED

19328	BR.17228	CABLE, POSITIVE, PORT UPPER T/C TO MAIN J/C - ASSEMBLY (MOD.196)	1	-	P	81/
19331	BR.17234	CABLE, POSITIVE, STARBOARD UPPER T/C J/C TO MAIN J/C BOX - ASSEMBLY (MOD.196)	1	-	P	81/
19332	BR.17236	CABLE, POSITIVE, PORT LOWER T/C J/C TO MAIN J/C - ASSEMBLY (MOD.196)	1	-	P	81/
19335	BR.17242	CABLE, POSITIVE, STARBOARD LOWER T/C J/C BOX TO MAIN J/C - ASSEMBLY (MOD.196)	1	-	P	81/
19329	BR.17230	CABLE, NEGATIVE, PORT UPPER T/C TO MAIN J/C - ASSEMBLY (MOD.196)	1	-	P	81/
19330	BR.17232	CABLE, NEGATIVE, STARBOARD UPPER T/C BOX TO MAIN J/C BOX - ASSEMBLY (MOD.196)	1	-	P	81/8
19333	BR.17238	CABLE, NEGATIVE, PORT LOWER T/C J/C TO MAIN J/C - ASSEMBLY (MOD.196)	1	-	P	81/4
19334	BR.17240	CABLE, NEGATIVE, STARBOARD LOWER T/C J/C TO MAIN J/C - ASSEMBLY (MOD.196)	1	-	P	81/1
19321	BR.17148	CLIP AND BOSS, T/C HARNESS - ASSEMBLY (MOD.196)	8	-		81/42
	BR.26736	CONDUIT, PORT SIDE, LOWER T/C HARNESS - ASSEMBLY (MOD.196)	1	-		81/3
	BR.26738	CONDUIT, STARBOARD, LOWER T/C HARNESS - ASSEMBLY (MOD.196)	1	-		81/19
	BR.26740	CONDUIT, PORT AND STARBOARD, INTERMEDIATE T/C HARNESS - ASSEMBLY (MOD.196)	2	-		81/51
	BR.26742	CONDUIT, PORT SIDE, UPPER T/C HARNESS - ASSEMBLY (MOD.196)	1	-		81/52
	BR.26744	CONDUIT, STARBOARD SIDE, UPPER T/C HARNESS - ASSEMBLY (MOD.196)	1	-		81/10

RESTRICTED

Avon 208

INSTALLATION FITTINGS - CONTINUED

Page 457

A, L, 24

REF. No.	PART No.						DESCRIPTION	No. OFF	MATL. SPEC.	M.R. C.L. of ST.	PL. & ILL. No.
		1	2	3	4	5					
36VV/12615	BA76677*	FERRULE					thermocouple harness - CONTINUED cables to main junction box (Pre-Mod 196)	1	Rubber	C	-
36VV/12173	BA80094*	FERRULE					cable, short (Pre-Mod 196)	2	Rubber	C	-
36VV/12174	BA80095*	FERRULE					cable, long (Pre-Mod 196)	2	Rubber	C	-
36VV/17890	BR23632	SCREW	2				B.A. x 1.300" long, clamping blocks (Mod 184)	2	NS	C	81/35
36VV/12175	BA80106	SCREW					hollow, .3115" x 1.425" long, main junction box	1	NS	C	81/24
36VV/12172	BA80093	SCREW	2				B.A. x .575" long, Main junction box top half Thermocouple junction boxes top halves	-	NS	C	-
								1			81/16
								4			81/7
36VV/12171	BA80092	SCREW	2				B.A. x .550" long, thermocouples junction box terminal block	8	NS	C	81/12
36VV/12170	BA80091	SCREW					.250" x .925" long, thermocouple junction box	4	NS	C	81/4
36VV/17219	BR22779	SCREW	2				B.A. x .650" long, main junction box terminal block (Mod 184)	4	NS	C	81/38
36VV/18079	BK3864	SCREW					.250" x .425" long, clip T/C harness (Mod 196)	16	NCS	-	81/44
36VV/1289812	KM171	SCREW	2				B.A. x .450" long, 'T' pieces T/C harness (Mod 196)	8	NS	-	81/45
36VV/12146	BA76687	SPRING					clamping block	2	Sp Stl	C	81/32
36VV/12176	BA80107	THERMOCOUPLE					- ASSEMBLY (KLG TYPE F 1065)	8	-	P	81/11
36VV/19324	BR17219	'T' PIECE					UPPER HALF, THERMOCOUPLE HARNESS - ASSEMBLY (MOD 196)	2	-	-	81/47
36VV/19325	BR17223	'T' PIECE					BOTTOM HALF, THERMOCOUPLE HARNESS - ASSEMBLY (MOD 196)	2	-	-	81/48
36VV/2977	K4529*	WASHER					plain, .450" o/dia. x .187" i/dia. x .025" thick	2	MS	C	-
36VV/2977	K4530						clamping block spring (Pre-Mod 2812)				
2840-99-1016835	K11703	WASHER					plain, chamfered, .450" o/dia. x .195" i/dia. x .050" thick, clamping block spring (Mod 2812)	2	St Stl	C	81/33

RESTRICTED

THERMOCOUPLE HARNESS -  
CONTINUED

36JJ/2968	K.8831	WASHER, plain, .400" o/dia x .195" i/dia x .018" thick, main junction box terminal block securing screw	4	St.Stl	C	81/36
56DD/1386	KJ.4506	WASHER, spring, Grover, .343" o/dia x .197" i/dia x .070" thick, Clamping block securing screw	-	Spg.Stl	C	
		Main junction box top half securing screw	2			81/36
		Thermocouple junction box top half securing screw	1			81/17
		"T" pieces T/C harness (Mod.196)	1			81/6
			8	Spg.Stl		
28W/3089	K.3803	) WASHER, spring, Thackeray, 2 B.A., Main junction box terminal block securing screws	-	Spg.Stl	C	
28W/6307	AGS.586/ ) C.)		4			81/37
		Thermocouple junction box terminal block securing screws	8			81/13
36HH/926	KB.7130	WASHER, tab, .317" i/dia., Main junction box securing screw	-	St.Stl	C	
		Thermocouple junction boxes securing screws	1			81/25
			4			81/3
17672	KB.7106	WASHER, tab, .250" i/dia., clip T/C harness (Mod.196)	16	St.Stl	C	81/43

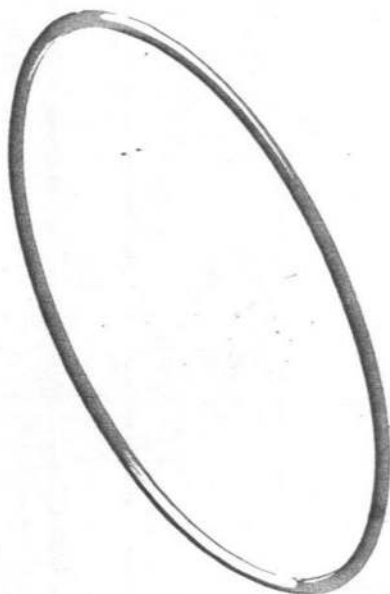

1/459

RESTRICTED

INSTALLATION FITTINGS - CONTINUED

No.	PART No.						DESCRIPTION	No. OFF	MATL. SPEC.	M.R. C.L. of ST.	PL. & ILL. No.
		1	2	3	4	5					
						L. P. AIR STARTER					
641	BR46182*					RING, sealing, LP air starter spigot (Mod 2466) (Pre-Mod 3459)	1	Rubber	C	-	
638	BR73247					RING, sealing, LP air starter spigot (Mod 3459)	1	Rubber	C	81A/1	

RESTRICTED

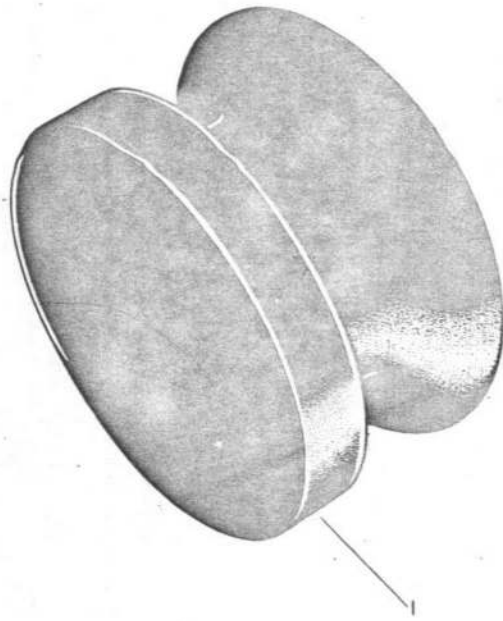

Avon 208  
A.L.5

INSTALLATION FITTINGS - CONTINUED

PL. &  
ILL. N

TRANSPORTATION PARTS

Thermocouple Harness

	BA.91108*	PLUG, blanking, main junction box outlet (Pre-Mod.221)	1	-	
19460	BR.37539	PLUG, blanking, main junction box outlet (Mod.221)	1	-	81B/1

Avon 208

A.L. 5

RESTRICTED

Page 461 not issued.

RESTRICTED

This file was downloaded  
from the RTFM Library.

Link: [www.scottbouch.com/rtfm](http://www.scottbouch.com/rtfm)

Please see site for usage terms,  
and more aircraft documents.

