

CONTROLS

RUDDER PEDAL ARRANGEMENT

Ref. No.	Part No.	Description	No. off						Material Specification	Class of Store or L.M	Place No.
			1	2	3	4	5	6			
	—	INSTALLATION OF RUDDER PEDALS						1	—	—	
		(Drg. No. 10-20 CF 1331/1)									
	10-20 CF 10035A/ND	PEDAL , rudder, assembly (Mod. 567)... ..						1	—	—	CF1
	10-20 CF 10033A	ADJUSTER , assembly (Mod. 567)						1	—	—	CF1
	—	CORD , 18"0 long						1	BS.4F32	—	
15925	10-20 CF 10021	HOUSING , spring and plunger pin (Mod. 567)						1	—	C	CF1
9748	10-20 CF 8707A	KNOB , assembly						1	—	C	
		Attachments for 10-20 CF 8707A, Knob :—									
	DHS.94/3/45	Pin, $\frac{3}{8}$ " dia., ground steel						1	S.96	—	CF1
2780	10-20 CF 1369	Shim, Attewell						1	—	C	CF1
	2776	PIN , hinge						1	—	C	CF1
	27FP/823	PIN , "Pip." quick release						1	—	C	CF1
	28P/1040	PIN , plunger pin guide						1	—	C	
		Attachments for SP.4Y'D18, Pin :—									
	28P/9527619	Pin, split (SP.9 C8)						1	—	C	
	28W/9418921	Washer						1	—	C	
	13912	PIN , retaining plunger (Mod. 530)						1	—	C	CF1
	2778	ROD , connecting						1	—	C	CF1
	2775	SPRING						1	—	C	CF1
		Attachments for 10-20 CF 10033A, Adjuster :—									
	2769	Screw, retaining						2	—	C	CF1
	2A/9500423	BEARING , ball, L.H. pivot bracket (3110-99-950-0423) (Pack with anti-freeze grease, DTD.825A, Ref. No. 34D/100512)						2	—	C	
	2A/9500419	BEARING , ball, R.H. pivot bracket (3110-99-950-0419) (Pack with anti-freeze grease, DTD.824A, Ref. No. 34D/100512)						2	—	C	
	—	BRACKET , pivot, L.H., rudder pedal mechanism, group						1	—	—	
	2A/9501453	BEARING , ball (3110-99-950-1453) (Pack with anti-freeze grease, DTD.825A, Ref. No. 34D-100512)						1	—	C	
	2767	BRACKET , pivot						1	—	C	CF1 CF2
	—	BRACKET , pivot, R.H., rudder pedal mechanism, group						1	—	—	
	2A/9501453	BEARING , ball (3110-99-950-1453) (Pack with anti-freeze grease, DTD.825A, Ref. No. 34D 100512)						1	—	C	
	2768	BRACKET , pivot						1	—	C	CF1
	13911	BRACKET , retaining, at R.H. end of sleeve ... (Mod. 530)						1	—	C	CF1
		Attachments for 10-20 CF 9625, Bracket :—									
	13910	Clip, locking, assembly						1	—	C	CF1
	13909	Pin, locking						2	—	C	CF1
	28S/9435712	Screw, 4 BA						2	—	C	
	28W/9415465	Washer						2	—	C	

CONTROLS
RUDDER PEDAL ARRANGEMENT

Ref. No.	Part No.	Description	No. off						Material Specification	Class of Store or L.M.	Place No.	
			1	2	3	4	5	6				
	10-20 CF 7509A	CRANK, L.H., assembly							1	—	—	CF2
	10-20 CF 7510A	CRANK, R.H., assembly							1	—	—	CF2
		Spares for :—										
9482	10-20 CF 655	BUSH, crank, elbow (See Repair section PA)							1	—	C	CF2
	10-20 CF 1733	CRANK, bare						DTD.423	1	—	—	CF2
7066	10-20 CF 1599A/ND	EYE-END, L.H., assembly							1	—	P	CF2
12400	10-20 CF 1600A/ND	EYE-END, R.H., assembly							1	—	P	CF2
2763	10-20 CF 673ND	CIRCLIP							2	—	C	CF2
2762	10-20 CF 661	EYE-END							1	—	C	CF2
26DV/3486	10-20 FC 323	EYE-END							1	—	C	CF2
28N/13511	HOFFMANN C.J.1	JOINT, self aligning							2	—	C	CF2
28M/1007403	A27/ET	NUT, 1/2" BSF							1	—	C	
		Attachments for 10-20 CF 1599A/ND or 10-20 CF 1600A/ND, Eye-end :—										
	2764	Pin							1	—	C	CF2
	28P/9527619	Pin, split (SP.9/C8)							1	—	C	
	2765	Spacer							1	—	C	CF2
	28W/9419405	Washer							1	—	C	
	2761	PIN, bearing							2	—	C	CF2
		Attachments for 10-20 CF 659, Pin :—										
	28M/1006473	Nut, 2 BA							1	—	C	
	28W/9419475	Washer							1	—	C	
	2760	TRUNNION							1	—	C	CF2
		Attachments for 10-20 CF 7509A, or 10-20 CF 7510A, Crank :—										
	2766	Bolt							2	—	C	CF1
	28M/13935	Nut, 1/2" BSF							2	—	C	
	28P/9527619	Pin, split (SP.9/C8)							2	—	C	
	28W/9418920	Washer							2	—	C	
	28W/9419456	Washer							2	—	C	
	10-20 CF 689	FORK-END, R.H. end of adjusting tube ...							1	DTD.423	—	CF1
		Attachments for 10-20 CF 689, Fork-end :—										
	28P/831	Pin, shackle							1	—	C	
	28P/9527619	Pin, split (SP.9/C8)							1	—	C	
	28W/9419475	Washer							1	—	C	
	10-20 CF 1591A	PEDAL, rudder, L.H., assembly							1	—	—	CF1
	10-20 CF 1592A	PEDAL, rudder, R.H., assembly							1	—	—	CF1
	10-20 CF 7277ND	COVER, rudder pedal (Shore hardness 50-55) 3".95 x 4".80 x 1/8" thick Attach with Boscoprene, parts 1 + 2 with Boscolite Primer 9247						Hallprene	1	—	LM	CF1
		Attachments for 10-20 CF 7277ND, Cover :—										
	28D/1215515	Bolt, 2 BA							1	—	C	
	28D/1215514	Bolt, 2 BA							4	—	C	
	28M/10281	Nut, 2 BA							2	—	C	
	10-20 CF 7573	Strip, retaining						L.72	1	—	LM	CF1
	10-20 CF 7575	Strip, retaining						L.72	1	—	LM	CF1
	27VA/5419	CYLINDER, master, rudder pedal actuating (For Spares see A.P.4515C, Vol. 3, Pt. 1, Sect. 2, Chap. 61)							1	—	P	CF1

CONTROLS

RUDDER PEDAL ARRANGEMENT

Ref. No.	Part No.	Description	No. off	Material Specification	Class of Store or L.M	Place No.
2746	10-20 CF 1445A	PEDAL , brake, L.H., assembly	1	—	P	CF1
2747	10-20 CF 1446A	PEDAL , brake, R.H., assembly	1	—	P	CF1
2956	DHS.418/1/G/70	Spares for :—				
2748	10-20 CF 1449	BUSH (See Repair section PA)	2	—	C	CF1
		PAD , rubber (Attach with Boscoprene, parts 1 + 2 with Boscolite Primer 9247)	1	—	C	CF1
	10-20 CF 7253	PLATE , guard, 20 SWG	1	L.72	LM	CF1
	10-20 CF 1453	PLATE , torque	1	S.3	—	CF1
		Attachments for 10-20 CF 1445A or 10-20 CF 1446A, Pedal :—				
2749	10-20 CF 1457	Bolt, pivot	1	—	C	CF1
28M/1011467	A27/E5	Nut, 1/4" BSF	1	—	C	
28P/9527619	SP.90/C7	Pin, split (SP.9/C8)	1	—	C	
28VV/9419405	SP.15/E	Washer	1	—	C	
7068	10-20 CF 1589A	PEDAL , rudder, L.H., assembly	1	—	P	CF1
7069	10-20 CF 1590A	PEDAL , rudder, R.H., assembly	1	—	P	CF1
		Spares for :—				
	10-20 CF 7255	BLOCK , guard, L.H.	1	LFS.21	LM	CF1
	10-20 CF 7257	BLOCK , guard, L.H.	1	LFS.21	LM	CF1
	10-20 CF 7256	BLOCK , guard, R.H.... ..	1	LFS.21	LM	CF1
	10-20 CF 7258	BLOCK , guard, R.H.... ..	1	LFS.21	LM	CF1
2750	10-20 CF 1459	PAD , rubber (Attach with Boscoprene, parts 1 + 2 plus Boscolite Primer 9247)	1	—	C	CF1
		Attachments for 10-20 CF 1589A or 10-20 CF 1590A, Pedal :—				
2751	10-20 CF 1451	Bolt	1	—	C	CF1
28M/1011467	A27/ES	Nut, 1/4" BSF	1	—	C	
28P/9527619	SP.90/C7	Pin, split (SP.9/C8)	1	—	C	
26FN/3263	DHS.69/EE	Shim	QR	—	C	
28VV/9419405	SP.15/E	Washer	1	—	C	
7067	10-20 CF 1593	SPIGOT , eccentric, toe motor... ..	1	—	C	CF1
		Attachments for 10-20 CF 1593, Spigot :—				
28M/5808571	A27/GS	Nut, 3/8" BSF	1	—	C	
28M/13935	A58/ES	Nut, 1/2" BSF	1	—	C	
28P/9527619	SP.90/C7	Pin, split (SP.9/C8)	2	—	C	
28VV/9419405	SP.15/E	Washer	1	—	C	
28VV/9419476	SP.15/G	Washer	1	—	C	
7071	10-20 CF 7409	PIN , stop, adjusting tube	1	—	C	CF2
		Attachments for 10-20 CF 7409, Pin :—				
28P/1021104	SP.90/C3	Pin, split (SP.9/C4)	2	—	C	
2771	10-20 CF 1013	RING , locking, bearing, R.H. pivot bracket ...	2	—	C	CF2
2754	10-20 CF 1015	RING , locking, L.H. bearing, L.H. pivot bracket	1	—	C	CF2
2755	10-20 CF 1017	RING , locking, R.H. bearing, L.H. pivot bracket ...	1	—	C	CF2
	10-20 CF 1349	ROD , adjusting, inside adjusting tube	1	S.92	—	CF2
	10-20 CF 9623	SLEEVE , adjusting tube (Mod. 530)	1	—	—	CF2
		(For spares use 10-20 CF 10017ND)				
19205	10-20 CF 10017ND	SLEEVE , adjusting tube (Spares condition) ...	1	—	C	CF2
	10-20 CF 687	SPOOL , adjusting tube (For spares use 10-20 CF 8733ND)	1	S.80	—	CF2
2759	10-20 CF 8733ND	SPOOL , adjusting tube (Spares condition) ...	1	—	C	
		Attachments for 10-20 CF 687, Spool :—				
2957	DHS.94/6/110	Pin, 3/8" dia, ground steel	4	—	C	CF2

CONTROLS
RUDDER PEDAL ARRANGEMENT

Ref. No.	Part No.	Description	No. off	Material Specification	Class of Store or L.M.	Plate No.
		SPRING , adjuster, group (Drg. No. 10-20 CF 1515)	1	—	—	
2756	10-20 CF 1513	ADJUSTER , spring	1	—	C	CF2
2758	10-20 CF 1475	HOUSING , spring	1	—	C	CF2
		Attachments for 10-20 CF 1475, Housing :—				
28D/9436920	A25/4E	Bolt, 1/4" BSF	2	—	C	
28D/1013175	AS.1242/8E	Bolt, 1/4" BSF	1	—	C	
28M/1011475	A27/EP	Nut, 1/4" BSF	3	—	C	
28DV/8092	DHS.204/E	Washer	3	—	C	CF1
13913	10-20 CF 9585	SPRING (Mod. 530)	1	—	C	CF2
2752	10-20 CF 1011	STOP , bearing, R.H., pivot bracket	1	—	C	CF2
12559	10-20 CF 9261	TUBE , adjusting	1	—	C	CF1
						CF2
8348	10-20 CF 7501A	TUBE , pedal crank, assembly (Mod. 49)	2	—	P	CF1
9483	10-20 CF 721	BUSH , plug, end, at pivot bracket (See Repair section PA)	1	—	C	CF1
9484	10-20 CF 1209	BUSH , plug, end, at rudder pedal (See Repair section PA)	1	—	C	CF1
	10-20 CF 719	PLUG , end, at pivot bracket	1	L.53	—	CF1
	10-20 CF 1739	PLUG , end, at rudder pedal (Mod. 49)	1	DTD.432	—	CF1
		Attachments for 10-20 CF 719 or 10-20 CF 1739, Plug :—				
26FC/10543	DHS.94/8/120	Pin, 1/4" dia., ground steel	2	—	C	CF1
	10-20 CF 893ND	TUBE , bare, 1" o/d x 20 SWG x 9" 30 long	1	L.63	—	CF1
		Attachments for 10-20 CF 7501A, Tube :—				
2784	10-20 CF 695	Bolt, threaded 1/4" BSF	1	—	C	CF1
2766	10-20 CF 697	Bolt, threaded 1/4" BSF	1	—	C	CF1
28M/1011467	A27/ES	Nut, 1/4" BSF	2	—	C	
28P/9527619	SP.90/C7	Pin, split (SP.9/C8)	2	—	C	
28W/9419456	SP.10/J	Washer	1	—	C	
28W/9419405	SP.15/E	Washer	2	—	C	
8347	10-20 CF 7535A	TUBE , pedal crank, L.H., assembly (Mod. 49) ...	1	—	P	CF1
8350	10-20 CF 7503A	TUBE , pedal crank, R.H., assembly (Mod. 49) ...	1	—	P	CF1
9484	10-20 CF 1209	BUSH , plug end (See Repair section PA) ...	1	—	C	CF1
9483	10-20 CF 721	BUSH , socket end (See Repair section PA) ...	1	—	C	CF1
	10-20 CF 1739	PLUG , end, at pedal (Mod. 49)	1	DTD.423	—	CF1
		Attachments for 10-20 CF 1739, Plug :—				
26FC/10543	DHS.94/8/120	Pin, 1/4" dia., ground steel	2	—	C	CF1
	10-20 CF 1735	SOCKET , end, L.H. tube (Mod. 49)	1	DTD.423	—	CF1
	10-20 CF 1737	SOCKET , end, R.H. tube (Mod. 49)	1	DTD.423	—	CF1
		Attachments for 10-20 CF 1735 or 10-20 CF 1737, Socket :—				
	DHS.94/8/150	Pin, 1/4" dia., ground steel	2	5.96	—	CF1
	10-20 CF 725	TUBE , bare, 1" o/d x 18 SWG x 6" 65 long	1	T.45	—	CF1
		Attachments for 10-20 CF 7535A or 10-20 CF 7503A, Tube :—				
28D/1212208	A57/8E	Bolt, 1/4" BSF	1	—	C	
2784	10-20 CF 695	Bolt, threaded 1/4" BSF	1	—	C	CF1
2766	10-20 CF 697	Bolt, threaded 1/4" BSF	1	—	C	CF1
28M/13935	A58/ES	Nut, 1/4" BSF	1	—	C	
28M/1011467	A27/ES	Nut, 1/4" BSF	2	—	C	
28P/9527619	SP.90/C7	Pin, split (SP.9/C8)	3	—	C	
2785	10-20 CF 1367	Plate, locking	1	—	C	CF1
2765	10-20 CF 665	Spacer, 3/8" o/d	1	—	C	CF1
28W/9419405	SP.15/E	Washer	3	—	C	
28W/9419456	SP.10/J	Washer	1	—	C	

CONTROLS
RUDDER PEDAL ARRANGEMENT

Ref. No.	Part No.	Description	No. off	Material Specification	Class of Store or LM	Plate No.
7070	10-20 CF 7259	WASHER , bearing, R.H. pivot bracket ...	1	—	C	CF2
		Attachments for 10-20 CF 10035A/ND, Pedal :—				
28D/1011238	A25/3E	Bolt, 1/2" BSF	5	—	C	
28M/13935	A58/ES	Nut, 1/2" BSF	5	—	C	
28P/9527619	SP.90/C7	Pin, split (SP.9/C8)	5	—	C	
28W/9419405	SP.15/E	Washer	5	—	C	

CONTROLS
RUDDER PEDAL ARRANGEMENT

Ref. No.	Part No.	Description						No. of	Material Specification	Class of Store or L.M.	Plate No.
		1	2	3	4	5	6				

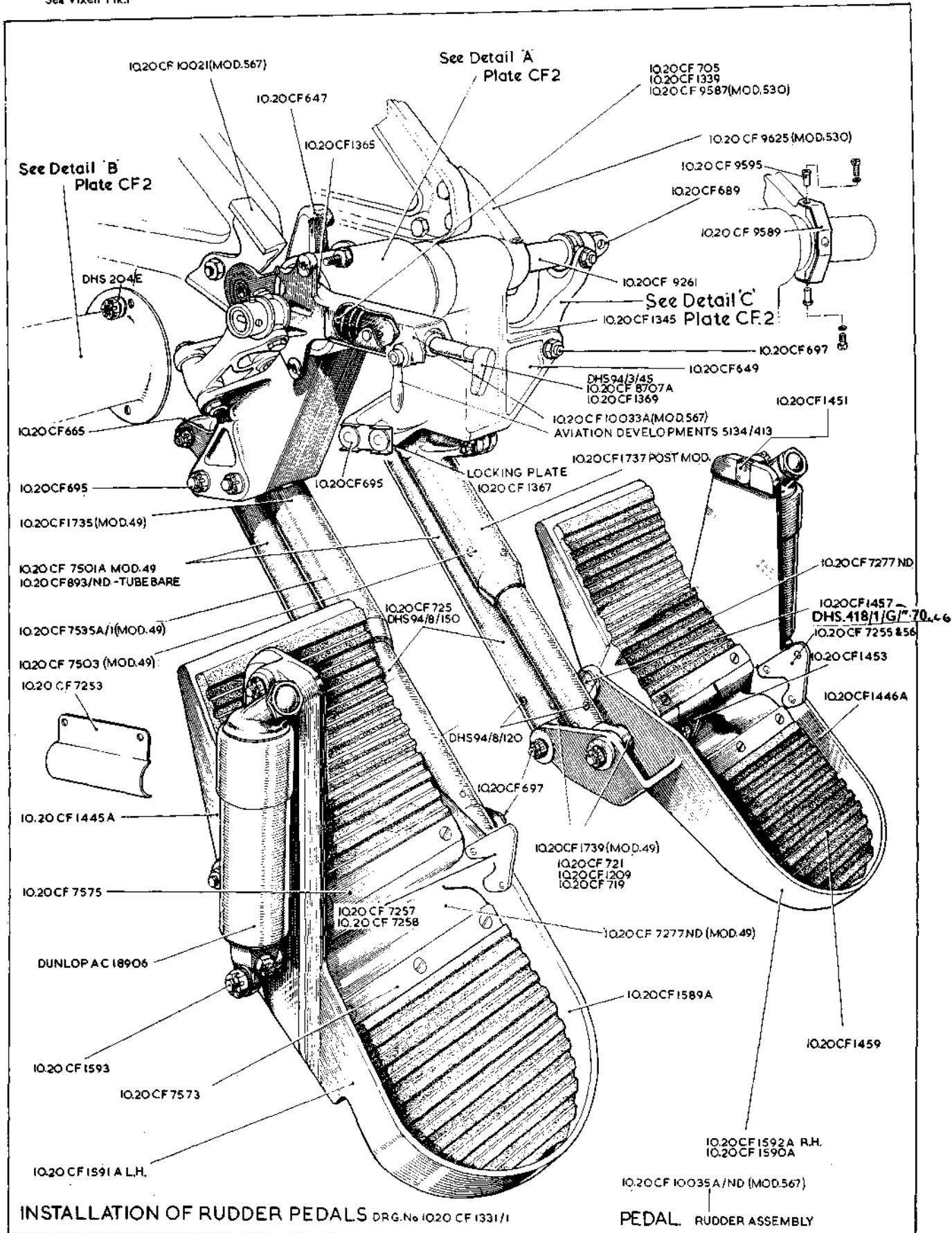

CF. I

CONTROLS RUDDER PEDAL ARRANGEMENT

CF. I

[A.L.32]

SEE TEXT FOR SPARES
CONDITION OF ITEMS MARKED THUS *

DETAILS ALONG THE LINE OF THE
ADJUSTING TUBE

PAGE CF1 X

Part No. 10-30-CF-655 Add at end of description (See Repair section PA)
Ref. No. 28M13124 Alter to 28M44006473
AC44

CF. 2

RUDDER PEDAL ARRANGEMENT
CONTROLS

CF. 2
[A.132]

RESTRICTED

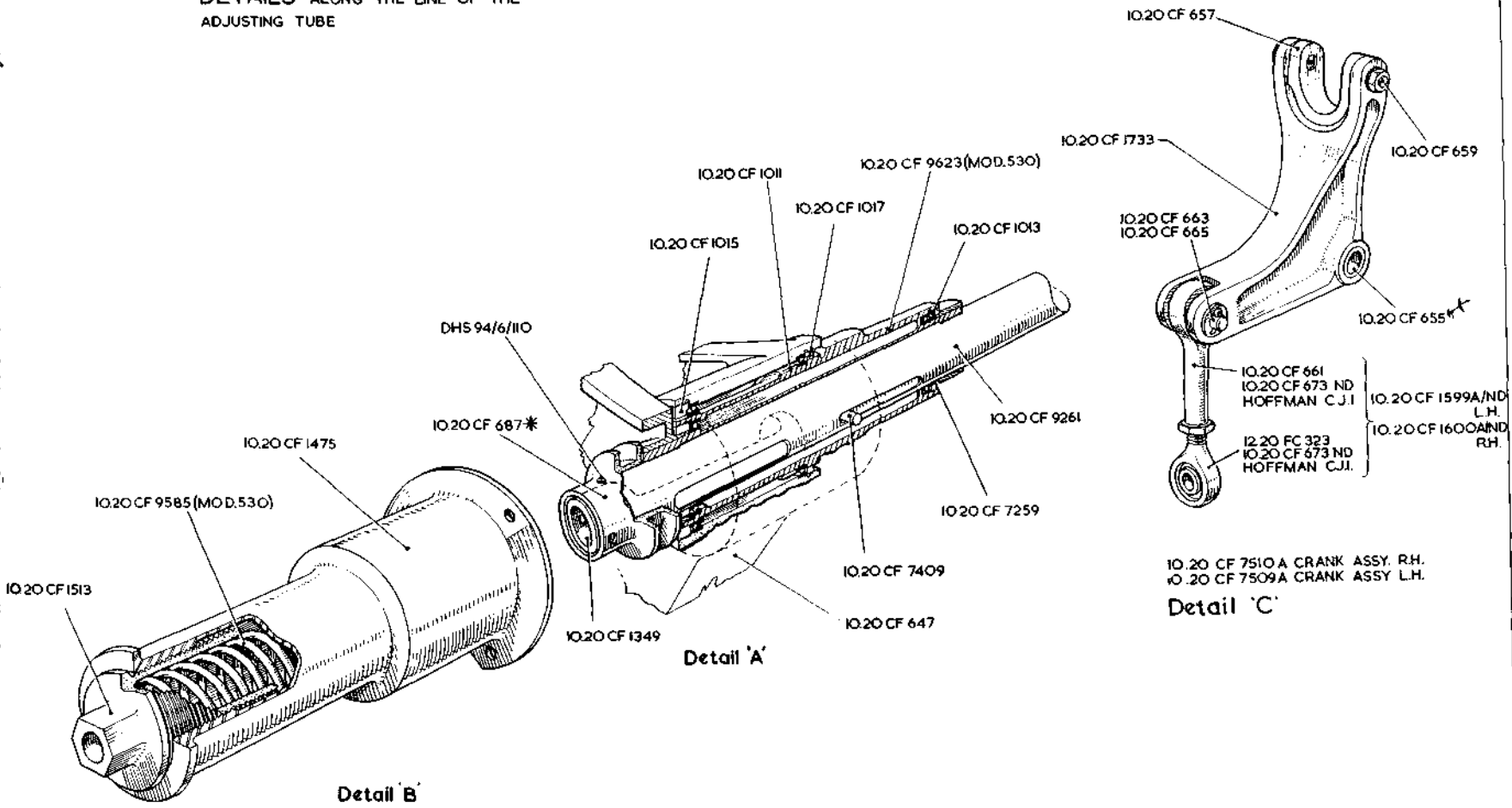

10.20 CF 7510A CRANK ASSY. RH.
10.20 CF 7509A CRANK ASSY. L.H.
Detail 'C'

This file was downloaded
from the RTFM Library.

Link: www.scottbouch.com/rtfm

Please see site for usage terms,
and more aircraft documents.

