

ELECTRICAL INSTALLATIONS

INSTALLATION OF AIR BRAKE CONTROL, CODED "CD"

Ref. No.	Part No.	Description	No. off	Material Specification	Class of Store or L.M	Plate No.
	--	INSTALLATION OF AIR BRAKE CONTROL, CODED "CD"	1	—	—	
	—	INSTALLATION AT FRONT PRESSURE BULK-HEAD, CODED "A" (Drg. No. 10-20 N 11421)	1	—	—	
	10-20 N 14911A	CABLE, bung A1, coded "Q," assembly (For cables circuit coded "CD")	1	—	ECC	EAC1
	—	INSTALLATION AT THROTTLE BOX AND GROUP CODED "F," FUSELAGE SIDE, PORT (Drg. Nos. 10-20 CE 4429A, 10-20 N 11421 and 10-20 N 13463)	1	—	—	
	—	BLOCK, terminal, coded "A," group	1	—	—	
	DHS.456/20	BLOCK, terminal, 20-way, assembly (For breakdown see DHS. Data Sheet)	1	—	—	EAC1
5X/9149643	PLESSEY CZ.25111	COVER, terminal block (5940-99-914-9643)	1	—	C	
12732	10-20 N 8085	PILLAR, fixing, 4 BA	2	—	C	EAC1
	10-20 N 9/545 Mk. 15	CABLE, coded "11.A.F.CD-CD.Q.Y.6," assembly	1	—	ECC	EAC1
	10-20 N 9/145 Mk. 2	CABLE, coded "12.A.F.CD - CD.H.CU.24," assembly	1	—	ECC	EAC1
	10-20 N 9/545 Mk. 3	CABLE, coded "12.A.F.CD-CD.Q.Y.5," assembly	1	—	ECC	EAC1
	10-20 N 22525A	CABLE, coded "JB1," assembly (Mod. 1030) (For cables circuit coded "CD")	1	—	ECC	EAC1
	10-20 N 10545A	SWITCH, coded "G," assembly (Pre Mod. 416)	1	—	—	
	10-20 N 12487A	SWITCH, coded "G," assembly (Mod. 416) ...	1	—	—	
	10-20 N 10545A/ CABLES	CABLE, assembly (Pre Mod. 416) (For cables circuit coded "CD")	1	—	ECC	EAC1
	10-20 N 12487A/ CABLES	CABLE, assembly (Mod. 416) (For cables circuit coded "CD")	1	—	ECC	EAC1
	FERRANTI	SWITCH	1	—	P	EAC1
SCW/6384	BXF.25853/35	Attachments for 10-20 N 10545A or 10-20 N 12487A, Switch :—				
28S/1200056	A33/A10	Screw, 6 BA	3	—	C	

ELECTRICAL INSTALLATIONS

INSTALLATION OF AIR BRAKE CONTROL, CODED "CD"

Ref. No.	Part No.	Description	No. off						Material Specification	Class of Store or L.M	Plate No.
			1	2	3	4	5	6			
		INSTALLATION AT L.H. CONSOLE ...									
		(Drg. No. 10-20 CE 4537A)									
	10-20 CE 8103A/ND	SWITCH , micro, coded "LZ," complete with mounting block, assembly (Mod. 1030)								EAC1	
	10-20 CE 4339	BLOCK , mounting					LFS.21		LM	EAC1	
28D/7002428	A25/6C	BOLT , 2 BA							C		
28M/10326	AGS.2002/A/1	NUT , 6 BA							C		
12249	10-20 CE 4291A	PLATE , mounting, assembly							C	EAC1	
	10-20 N 22527A	SWITCH , micro, complete with cable, assembly									
	10-20 N 22527A/ CABLES	CABLE , assembly							ECC	EAC1	
28S/9419436	A31/A6	SCREW , 6 BA (Fit in lieu of screws supplied with micro-switch)							C		
	5CW/4615	SWITCH , micro, Type V3							C	EAC1	
28W/1009659	SP.11/A	WASHER							C		
		INSTALLATION AT LOWER PANEL, CODED "H" (Drg. Nos. 10-20 N 15833A (Pre Mod. 803) and 10-20 N 15709A (Mod. 803)									
		BLOCK , fuse, coded "CU," group								EAC1	
		BLOCK , fuse, 12-way (See sub-section EBV)									
10H/23862		FUSE , 10 amp.							C	EAC1	
		INSTALLATION AT REAR PRESSURE BULK-HEAD, CODED "Q" (Drg. Nos. 10-20 N 10635 and 10-20 N 11421)									
		BLOCK , terminal, coded "AC," group									
	DHS.456/20	BLOCK , terminal, 20-way, assembly (For breakdown see DHS. Data Sheet)								EAC1	
5X/9149643	PLESSEY CZ.25111	COVER , terminal block (5940-99-914-9643)							C		
7657	DHS.870/5	PILLAR , fixing, 4 BA							C	EAC1	
5195	DHS.849	SCREW , slotted head (Pre Mod. 96)					QR		C		
26DV/12296	DHS.489/5	SPACER (Pre Mod. 96)							C	EAC1	
26DV/12296	DHS.489/5	SPACER , (Mod. 749)							C	EAC1	
	10-20 N 13469ND	SPACER (Make from Ref. No. 26DV/12296) (Mod. 749)						P.V.C.	LM		
		BLOCK , terminal, coded "AD," group									
	DHS.456/20	BLOCK , terminal, 20-way, assembly (For breakdown see DHS. Data Sheet)								EAC1	
5X/9149643	PLESSEY CZ.25111	COVER , terminal block (5940-99-914-9643)							C		
7657	DHS.870/5	PILLAR , fixing, 4 BA							C		
26DV/12296	DHS.489/5	SPACER							C		
	10-20 N 22525A	CABLE , coded "JB1," assembly (Mod. 1030) (For cables circuit coded "CD")							ECC	EAC1	
	10-20 N 9/545 Mk. 6	CABLE , coded "2.Y.Q.CD--CD*2.A.3," assembly							ECC	EAC1	
5CW/6453		SWITCH , magnetic, Type 9B No. 2A, coded "Y" Attachments for Ref. No. 5CW/6453, Switch:—							P	EAC1	
		Screw, 4 BA							C		
28S/9995376	A32/B20	Washer							C		
28W/9419401	SP.10/B										

ELECTRICAL INSTALLATIONS

INSTALLATION OF AIR BRAKE CONTROL, CODED "CD"

Ref. No.	Part No.	Description	No. off	Material Specification	Class of Store or L.M	Plate No.
28M/10288	AGS.2001/C/1	TERMINAL , earth, station 2, coded "A," group	1	—	—	
26DV/7529	DHS.438/C	NUT , 2 BA	2	—	C	
26DV/4969	DHS.437/C	TAG , corrosion	1	—	C	
		TERMINAL , earth, assembly	1	—	C	EAC1
		(For breakdown see DHS. Data Sheet)				
28W/9419475	SP.15/C	WASHER	2	—	C	
		INSTALLATION AT FLOOR STEP, STATION	1	—	—	
		148" (Drg. Nos. 10-20 N 9837 and 10-20 N 9199)				
	10-20 N 8771A/2	CABLE , coded "JB1," assembly (For cables circuit coded "CD")	1	—	ECC	EAC1
5X/6133	PLESSEY CZ.28057	PLUG , bulkhead, coded "JB1"	1	—	C	EAC1
		INSTALLATION AT ACCUMULATOR BAY	1	—	—	
		(Drg. Nos. 10-20 FS 8767, 10-20 FS 12751 and 10-20 N 9199)				
	10-20 N 9/145 Mk. 20	CABLE , coded "5.KU.CD—CD.JA.G.4," assembly	1	—	ECC	EAC1
	10-20 N 9/145 Mk. 18	CABLE , coded "A.KW.CD—CD.KU.1," assembly	1	—	ECC	EAC1
	10-20 N 9/145 Mk. 21	CABLE , coded "C.KW.CD—CD.JA.G.3," assembly	1	—	ECC	EAC1
		SWITCH , and stop plate, coded "KU," group	1	—	—	
	10-20 FS 16259	PLATE , stop, 20 SWG	1	L.72	LM	EAC1
28S/1008327	A32/B14	SCREW , 4 BA	4	—	C	
5CW/5831	—	SWITCH , tumbler	1	—	C	
28W/1200328	AGS.2037/B	WASHER	4	—	C	
5CW/9438275	—	SWITCH , micro, coded "KV" and "KW"	2	—	P	EAC1
		Attachments for Ref. No. 5CW/9438275, Switch :—				
28D/1214872	AS.1246/10B	Bolt, 4 BA	2	—	C	
28W/9419474	SP.15/B	Washer	2	—	C	
		INSTALLATION AT ACCUMULATOR BULK-HEAD, CODED "JA" (Drg. Nos. 10-20 N 8337, 10-20 N 12401 and 10-20 S 7015)	1	—	—	
		BLOCK , terminal, coded "JAG," group	1	—	—	
	DHS.456/20	BLOCK , terminal, 20-way, assembly	1	—	—	EAC1
		(For breakdown see DHS. Data Sheet)				
16180	10-20 N 10687A	COVER , terminal block, assembly	1	—	C	EAC1
16898	10-20 N 10685	COVER , bare	1	—	C	EAC1
	10-20 N 10683	SCREW , fixing, shouldered, 2 BA	2	BS.249	—	EAC1
	10-20 N 10681	SPACER , tapped, 2 BA	2	LFB.82 or 89	—	EAC1
12732	10-20 N 8085	PILLAR , fixing, 4 BA	2	—	C	EAC1
	10-20 N 9/145 Mk. 14	CABLE , coded "1.A.5*CD—CD.JD.C," assembly	1	—	ECC	EAC1
	10-20 N 9/145 Mk. 12	CABLE , coded "3.G.JA—CD.JD.A," assembly	1	—	ECC	EAC1
	10-20 N 9/145 Mk. 13	CABLE , coded "4.G.JA.CD—CD.JD.B," assembly	1	—	ECC	EAC1
		TERMINAL , earth, station 5, coded "A," group	1	—	—	
	10-20 N 2301	TAG , corrosion, 20 SWG	1	L.16	LM	EBG1
6608	10-20 N 2295A	TERMINAL , earth, 45°, assembly	1	—	C	EAC1
	10-20 N 2297A	BRACKET , assembly	1	—	LM	EBG1
	DHS.436ND	PLATE , doubling, 14 SWG	1	BS.265	LM	EBG1
	10-20 N 2299ND	PLATE , terminal, 16 SWG	1	BS.265	LM	EBG1
26DV/11786	AS.2751	CIRCLIP	4	—	C	
12687	DHS.379/1	LABEL , half	1	—	C	
12688	DHS.379/2	LABEL , half	1	—	C	
26DV/11785	AS.2749	SOCKET , half	8	—	C	
5H/76	AS.2747	SOCKET , assembly	4	—	C	
26DV/11787	AS.2752	SPACER	4	—	C	
		Attachments for 10-20 N 2295A, Terminal :—				
28D/1011030	A25/2E	Bolt, ½" BSF	2	—	C	
28M/10290	AGS.2001/E/1	Nut, ½" BSF	2	—	C	
28W/9418921	SP.13/E	Washer	4	—	C	

ELECTRICAL INSTALLATIONS

INSTALLATION OF AIR BRAKE CONTROL, CODED "CD"

Ref. No.	Part No.	Description	No. off	Material Specification	Class of Score or L.M.	Plate No.
32B/—	—	INSTALLATION AT LOWER ACCESSORY BAY	1	—	—	
	—	UNIT , selector, coded "JD" (See sub-section QT)	-	—	—	
	—	TAPE , Identification, numbers and letters, use from Ref. Nos. 32B/1087 to 32B/1120 inclusive, as required				

EAC.1

ELECTRICAL INSTALLATION

AIR BRAKE CONTROL

EAC.1
[A.43]

RESTRICTED

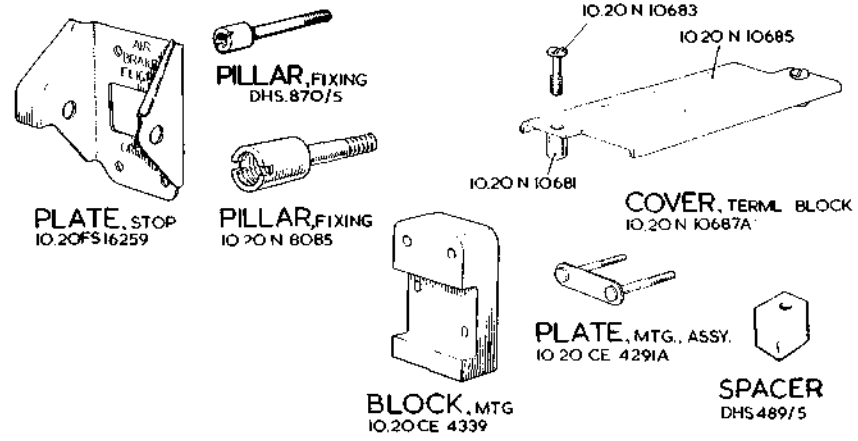
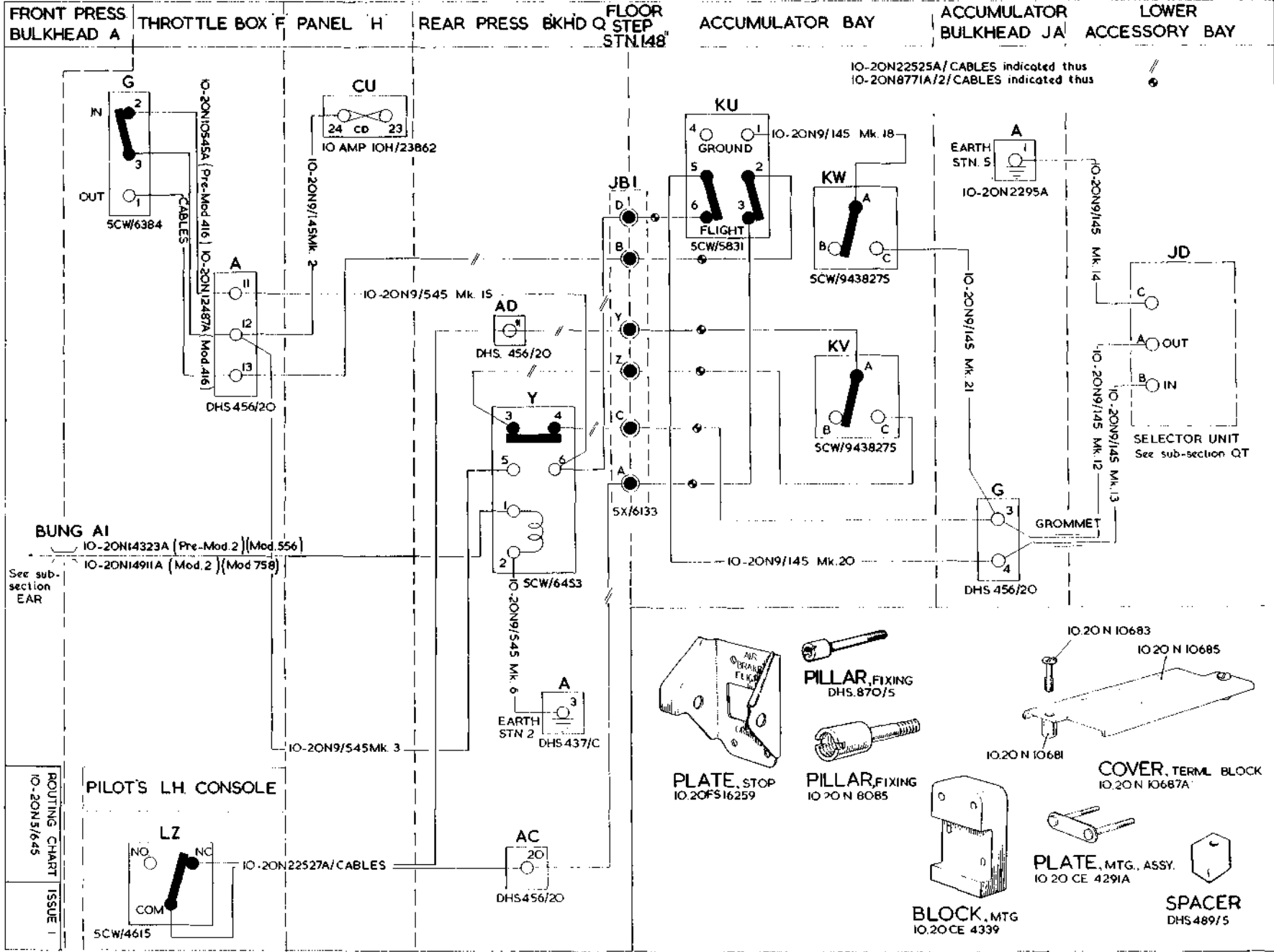

See Vixen Mk. 1

RESTRICTED

Plate EAC 1



This file was downloaded
from the RTFM Library.

Link: www.scottbouch.com/rtfm

Please see site for usage terms,
and more aircraft documents.