

**ELECTRICAL INSTALLATIONS  
WING-FOLD, RADOME AND NAVIGATOR'S HATCH  
LOCKING AND INDICATION, CODED "GW"**

Ref. No.	Part No.	Description	No. off	Material Specification	Class of Store or L.M.	Plate No.
	—	<b>INSTALLATION OF WING-FOLD, RADOME AND NAVIGATOR'S HATCH LOCKING AND INDICATION, CODED "GW"</b>	1	—	—	
	—	<b>INSTALLATION AT FUSELAGE NOSE</b> ... (Drg. Nos. 10-20 N 11421, 10-20 N 9465, 10-20 FS 20879 and 10-20 FS 11827)	1	—	—	
	—	<b>BLOCK</b> , terminal, coded "BA," group ...	1	—	—	
	DHS.456/20L	<b>BLOCK</b> , terminal, 20-way, assembly ... (For breakdown see DHS. Data Sheet)	1	—	—	EBE1
5X/9149643	PLESSEY CZ.25111	<b>COVER</b> , terminal block (5940-99-914-9643) ...	1	—	C	EBE3
16671	DHS.870/1	<b>PILLAR</b> , fixing, 4 BA ...	2	—	C	EBE3
5195	DHS.849	<b>SCREW</b> , special (Fit at terminals Nos. 13 and 14)	2	—	C	EBE1
	10-20 N 14911A	<b>CABLE</b> , bung "A1," assembly (For cables circuit coded "GW")	1	—	ECC	EBE1
	10-20 N 11173A	<b>SWITCH</b> , micro, complete with cables, coded "BK," assembly	1	—	ECC	EBE1
	10-20 N 11175A	<b>SWITCH</b> , micro, complete with cables, coded "BL," assembly	1	—	ECC	EBE1
		Attachments for 10-20 N 11173A and 10-20 N 11175A, Switches:—				
28D/1212279	A25/20B	Bolt, 4 BA (Locks to DHS.514/D) ...	1	—	C	
	10-20 FS 16117	Plate, nut ...	1	\$5.10	LM	KN5
11865	10-20 FS 14709ND	Spacer, bearing ...	1	—	C	KN5
28W/9419465	SP.13/B	Washer ...	1	—	C	
	DHS.783/18/16	Washer, 0".75 o/d x 0".156 i/d x 16 SWG ...	2	L.72	LM	KN5
11864	10-20 FS 14755ND	Washer, shim ...	1	—	C	KN5
	10-20 N 7021A	<b>SWITCH</b> , micro, complete with cables, coded "BR," assembly	1	—	ECC	EBE1
	10-20 N 7023A	<b>SWITCH</b> , micro, complete with cables, coded "BS," assembly	1	—	ECC	EBE1
		Attachments for 10-20 N 7021A or 10-20 N 7023A, Switch:—				
28D/1011014	A25/19B	Bolt, 4 BA ...	2	—	C	
28M/10287	AGS.2001/B/1	Nut, 4 BA ...	2	—	C	
28W/9419401	SP.10/B	Washer ...	2	—	C	
17324	10-20 WC 40715ND	Washer, Zinc, "005"-008 chick (Mod. 1134) ...	2	—	C	
	—	<b>INSTALLATION AT FRAME 96</b> (Drg. Nos. 10-20 N 11421 and 10-20 N 13463)	1	—	—	
	10-20 N 9/162 Mk. 13	<b>CABLE</b> , coded "19.DA.H.GWB-GWB.★1.B.5," assembly (Pre Mod. 803)	1	—	ECC	EBE1
	10-20 N 9/662 Mk. 28	<b>CABLE</b> , coded "5.B.1.★GWB-GWB.H.A.DA.19," assembly (Mod. 803)	1	—	ECC	EBE1
	—	<b>TERMINAL</b> , earth station 1, coded "B," group	1	—	—	
26DV/7529	DHS.438/C	<b>TAG</b> , corrosion ...	1	—	C	
26DV/4969	DHS.437/C	<b>TERMINAL</b> , earth, assembly ... (For breakdown see DHS. Data Sheet)	1	—	C	EBE1
		Attachments for DHS.437/C, Terminal:—				
28D/9137409	AS.1246/2C	Bolt, 2 BA ...	2	—	C	
28M/10288	AGS.2001/C/1	Nut, 2 BA ...	2	—	C	
28W/941904	SP.16/C	Washer ...	2	—	C	

**ELECTRICAL INSTALLATIONS  
WING-FOLD, RADOME AND NAVIGATOR'S HATCH  
LOCKING AND INDICATION, CODED "GW"**

Ref. No.	Part No.	Description	No. off	Material Specification	Class of Store or L.M	Plate No.
		<b>INSTALLATION AT PANEL, CODED "J"</b> (Drg. Nos. 10-20 N 14129A Pre Mod. 923, 10-20 N 15575A Mod. 923, Pre Mod. 803 and 10-20 N 14469A and 10-20 N 14273 Mod. 803)	1	—	—	
	10-20 N 14129A/ CABLES	<b>CABLES</b> , circuit coded "GW" (Pre Mod. 923)	QR	—	ECC	EBE1
	10-20 N 15575A/ CABLES	<b>CABLES</b> , circuit coded "GW" (Mod. 923, Pre Mod. 803)	QR	—	ECC	EBE1
	10-20 N 14469A/ CABLES	<b>CABLES</b> , circuit coded "GW" (Mod. 803)	QR	—	ECC	EBE1
5CZ/6257	DOWTY C.5165Y/P44	<b>INDICATOR</b> , electro magnetic, coded "H" (Pre Mod. 1050)	1	—	C	EBE1
5CZ/6697	DOWTY DN.1245Z Mk. 62	<b>INDICATOR</b> , electro magnetic, coded "H" (Mod. 1050)	1	—	C	EBE1
		<b>INSTALLATION AT PANEL, CODED "H" AND "H-A"</b> (Drg. Nos. 10-20 N 11421, 10-20 N 15781 Pre Mod. 803, 10-20 N 22229 Mod. 803 and 10-20 N 13987)	1	—	—	
	DHS.456/20L	<b>BLOCK</b> , terminal, coded "CL," group ...	1	—	—	
		<b>BLOCK</b> , terminal, 20-way, assembly ... (For breakdown see DHS. Data Sheet)	1	—	—	EBE1
5X/9149643 7657	PLESSEY CZ.25111 DHS.870/5	<b>COVER</b> , terminal block (5940-99-914-9643) ...	1	—	C	
26DV/12296	DHS.489/5	<b>PILLAR</b> , fixing, 4 BA ...	2	—	C	EBE3
		<b>SPACER</b> ...	2	—	C	EBE3
		<b>BLOCK</b> , terminal, coded "DA," group ... (Pre Mod. 803)	1	—	—	
28D/1010658	A25/1B	<b>BOLT</b> , 4 BA ...	1	—	C	
28D/9436920	A25/1C	<b>BOLT</b> , 2 BA, securing plate ...	1	—	C	
	10-20 N 7159	<b>PIECE</b> , distance ...	1	L.65	LM	EBE3
5X/9450403	PLESSEY Z.28426 10-20 N 7121A	<b>PILLAR</b> , fixing, 4 BA (5340-99-945-0403) ...	1	—	C	
	DHS.456/20L	<b>PLATE</b> , mounting, complete with terminal block, assembly	1	—	—	EBE3
		<b>BLOCK</b> , terminal, 20-way, assembly ... (For breakdown see DHS. Data Sheet)	1	—	—	EBE1
5X/9149643 28M/10327	PLESSEY CZ.25111 AGS.2002/B/1	<b>COVER</b> , terminal block (5940-99-914-9643)	1	—	C	
5X/9450403	PLESSEY Z.28426 10-20 N 7123ND	<b>NUT</b> , 4 BA ...	1	—	C	
		<b>PILLAR</b> , fixing, 4 BA (5340-99-945-0403) ...	1	—	C	EBE3
		<b>PLATE</b> , mounting, terminal block, 18 SWG	1	L.72	LM	EBE3
28W/9419401	SP.10/B	<b>WASHER</b> ...	1	—	C	
28W/9419465	SP.13/B	<b>WASHER</b> ...	1	—	C	
	DHS.456/20	<b>BLOCK</b> , terminal, coded "DA," group (Mod. 803)	1	—	—	
		<b>BLOCK</b> , terminal, 20-way, assembly ... (For breakdown see DHS. Data Sheet)	1	—	—	EBE1
5X/9149643	PLESSEY CZ.25111	<b>COVER</b> , terminal block (5940-99-914-9643) ...	1	—	C	
5X/9450403	PLESSEY Z.28426	<b>PILLAR</b> , fixing, 4 BA (5340-99-945-0403) ...	2	—	C	

**ELECTRICAL INSTALLATIONS  
WING-FOLD, RADOME AND NAVIGATOR'S HATCH  
LOCKING AND INDICATION, CODED "GW"**

Ref. No.	Part No.	Description	No. off	Material Specification	Class of Store or L.M	Place No.
	DHS.456/20L	<b>BLOCK</b> , terminal, coded "DB," group ...	1	—	—	—
		<b>BLOCK</b> , terminal, 20-way, assembly ... (For breakdown see DHS. Data Sheet)	1	—	—	EBE1
5X/9145643 5X/16165	PLESSEY CZ.25111	<b>COVER</b> , terminal block ...	1	—	C	—
7657	DHS.870/5	<b>PILLAR</b> , fixing, 4 BA ...	2	S.96	C	EBE3
26DV/12296	DHS.489/5	<b>SPACER</b> ...	2	P.V.C.	C	EBE3
	10-20 N 13713A	<b>CABLE</b> , bung "Q1," coded "FB," assembly (Mod. 482, Pre Mod. 2)	1	—	ECC	EBE1
	10-20 N 15683A	<b>CABLE</b> , bung "Q1," coded "FB," assembly (For cables circuit coded "GW")	1	—	ECC	EBE1
	10-20 N 22421A	<b>CABLE</b> , bung "Q1," coded "FB," assembly (Mod. 702, Pre Mod. 803)	1	—	ECC	EBE1
	10-20 N 22421A	<b>CABLE</b> , bung "Q1," coded "FB," assembly (For cables circuit coded "GW")	1	—	ECC	EBE1
	10-20 N 9/562 Mk. 20	<b>CABLE</b> , bung "Q1," coded "FB," assembly (Mods. 1091 and 803)	1	—	ECC	EBE1
	10-20 N 9/562 Mk. 20	<b>CABLE</b> , coded "10.DB.H.GWA-GWA.DW.2," assembly	1	—	ECC	EBE1
	10-20 N 12859A	<b>CABLE</b> , coded "ZS-H," assembly (Mod. 537, Pre Mod. 803)	1	—	ECC	EBE1
	10-20 N 15593A	<b>CABLE</b> , coded "ZS-HA," assembly (Mod. 803)	1	—	ECC	EBE1
		<b>INSTALLATION AT NAVIGATOR'S HATCH</b> (Drg. Nos. 10-20 N 7365, 10-20 FS 5099, 10-20 N 8553 Pre Mods. 7 and 2 and 10-20 N 11421 Mods. 2 and 7)	1	—	—	—
	10-20 N 10019A	<b>CABLE</b> , coded "AL-Q," assembly ...	1	—	ECC	EBE1
		<b>SWITCH</b> , micro, coded "AK," group ...	1	—	—	—
10294	10-20 FS 13845	<b>COVER</b> ...	1	L.72	C	EBE3
10296	10-20 FS 13841	<b>LEVER</b> ...	1	DHE.223	C	EBE3
10295	10-20 FS 13839	<b>PIN</b> , lever swivel ...	1	S.92	C	EBE3
10297	10-20 FS 13843	<b>SPRING</b> , micro switch lever ...	1	Comm'l. S.S.	C	EBE3
	10-20 N 12857A	<b>SWITCH</b> , micro, complete with cables, coded "ZS.AL-AK," assembly (Mod. 537)	1	—	ECC	EBE1
		Attachments for 10-20 N 12857A. Switch :-				
28E/14052	AS.3180/5C	Clip, "P" ...	4	—	C	—
28M/10287	AGS.2001/B/1	Nut, 4 BA ...	2	—	C	—
28M/10288	AGS.2001/C/1	Nut, 2 BA ...	4	—	C	—
28S/—	AS.2992/9B	Screw, 4 BA ...	2	—	—	—
28S/1011490	A32/C16	Screw, 2 BA ...	4	—	C	—
5F/2279	—	Strap, flexible, cable fastening, 1/2" wide	QR	P.V.C.	C	—
5F/2280	—	Stud, cable fastening strap	QR	Nylon	C	—
28W/9419465	SP.13/B	Washer ...	2	—	C	—
28W/9419402	SP.13/C	Washer ...	4	—	C	—
		<b>INSTALLATION AT WING-FOLD SELECTOR LEVER AND PILOT'S R.H. REAR CONSOLE</b> (Drg. Nos. 10-20 CE 2751A and 10-20 N 14335)	1	—	—	—
	DHS.456/2	<b>BLOCK</b> , terminal, coded "DW," group ...	1	—	—	—
		<b>BLOCK</b> , terminal, 2-way, assembly ... (For breakdown see DHS. Data Sheet)	1	—	—	EBE1
		<b>COVER</b> , terminal block ...	1	—	C	—
5X/3272	PLESSEY CZ.26799	<b>PILLAR</b> , fixing, 4 BA ...	2	—	C	EBE3
5X/9450403 5X/3272	PLESSEY Z.28426	<b>CABLE</b> , coded "1.DW.GWA-GWA.★2.A.4," assembly	1	—	ECC	EBE1
	10-20 N 9/562 Mk. 4					

**ELECTRICAL INSTALLATIONS  
WING-FOLD, RADOME AND NAVIGATOR'S HATCH  
LOCKING AND INDICATION, CODED "GW"**

Ref. No.	Part No.	Description	No. off	Material Specification	Class of Store or L.M	Plate No.
5CW/6164	10-20 CE 2751A/ CABLES ROTAX LTD. D.5317	<b>CABLES</b> , circuit coded "GW" ... ..	QR	—	ECC	EBE1
		<b>SOLENOID</b> , coded "AA," assembly ... ..	1	—	P	EBE1
		Attachments for D.5317, Solenoid :—				
28M/10288	AGS.2001/C/1	Nut, 2 BA ... ..	3	—	C	
28S/9435713	A31/C20	Screw, 2 BA ... ..	3	—	C	
4106	10-20 CE 2815	Shim, "Attewell" ... ..	QR	LA.3	C	EBE2
28W/9419402	SP.13/C	Washer ... ..	3	—	C	
5CW/4638	—	<b>SWITCH</b> , micro, coded "AG," assembly ... ..	1	—	P	EBE1
		Attachments for Ref. No. 5CW/4638, Switch :—				
28D/1011011	A25/8B	Bolt, 4 BA (Lock to DHS.514/D) ... ..	2	—	C	
28W/9419465	SP.13/B	Washer ... ..	2	—	C	
	—	<b>INSTALLATION AT REAR PRESSURE BULK- HEAD, CODED "Q"</b> (Drg. Nos. for use on Pre Mod. 2 A/C :— 10-20 N 8553 and 10-20 N 7907) (Drg. Nos. for use on Mod. 2 A/C :— 10-20 N 11421 and 10-20 N 10635)	1	—	—	
	DHS.456/20	<b>BLOCK</b> , terminal, coded "AD," group ... ..	1	—	—	
		<b>BLOCK</b> , terminal, 20-way, assembly ... ..	1	—	—	EBE1
		(For breakdown see DHS. Data Sheet)				
61. 5x/9149 643 5x/6465	PLESSEY CZ.25111	<b>COVER</b> , terminal block ... ..	1	—	C	
7657	DHS.870/5	<b>PILLAR</b> , fixing, 4 BA ... ..	2	S.96	C	EBE3
26DV/12296	DHS.489/5	<b>SPACER</b> ... ..	2	P.V.C.	C	EBE3
	10-20 N 14089A	<b>CABLE</b> , bung "Q3," coded "FB," assembly (Mod. 249) (For cables circuit coded "GW")	1	—	ECC	EBE1
	10-20 N 8729A/4	<b>CABLE</b> , bung "Q6," coded "FA," assembly (Pre Mods. 728 and 2) (For cables circuit coded "GW")	1	—	ECC	EBE1
	10-20 N 14337A	<b>CABLE</b> , bung "Q6," coded "FA," assembly (Mod. 728) (For cables circuit coded "GW")	1	—	ECC	EBE1
	—	<b>TERMINAL</b> , earth station 2, coded "A," group	1	—	—	
26DV/7529	DHS.438/C	<b>TAG</b> , corrosion ... ..	1	L.16	C	
26DV/4969	DHS.437/C	<b>TERMINAL</b> , earth, assembly (For breakdown see DHS. Data Sheet)	1	—	C	EBE1
		Attachments for DHS.437/C, Terminal :—				
28M/10288	AGS.2001/C/1	Nut, 2 BA ... ..	2	—	C	
28W/9419475	SP.15/C	Washer ... ..	2	—	C	
	—	<b>INSTALLATION AT PORT WING DECK PANEL, CODED "FA"</b> (Drg. Nos. for use on Pre Mod. 2 A/C :— 10-20 N 8861, 10-20 N 13625A, 10-20 N 10113, 10-20 N 2747, 10-20 N 2655 and 10-20 N 13431A) (Drg. Nos. for use on Mod. 2 A/C :— 10-20 N 11211, 10-20 N 13301A, 10-20 N 13521A, 10-20 N 11143, 10-20 N 11609 and 10-20 N 10109)	1	—	—	
	—	<b>BLOCK</b> , fuse, coded "W," group ... ..	1	—	—	
	—	<b>BLOCK</b> , fuse, 12-way (See sub-section EBV)	—	—	—	
10H/23862	—	<b>FUSE</b> , 10 amp. ... ..	3	—	C	EBE1

**ELECTRICAL INSTALLATIONS  
WING-FOLD, RADOME AND NAVIGATOR'S HATCH  
LOCKING AND INDICATION, CODED "GW"**

Ref. No.	Part No.	Description	No. off	Material Specification	Class of Store or L.M	Place No.
	— DHS.456/20	<b>BLOCK</b> , terminal, coded "D," group ... ..	1	—	—	
		<b>BLOCK</b> , terminal, 20-way, assembly ... .. (For breakdown see DHS. Data Sheet)	1	—	—	EBE1
28D/12182	AS.1246/6B	<b>BOLT</b> , 4 BA (Mod. 963) ... ..	2	—	C	
5X/9149643	PLESSEY CZ.25111	<b>COVER</b> , terminal block (Pre Mod. 963) ... ..	1	—	C	
5X/9450403	PLESSEY Z.28426	<b>PILLAR</b> , fixing, 4 BA (Pre Mod. 963) ... ..	2	—	C	EBE3
28W/9419474	SP.15/B	<b>WASHER</b> ... ..	2	—	C	
	— DHS.456/20	<b>BLOCK</b> , terminal, coded "E," group ... ..	1	—	—	
		<b>BLOCK</b> , terminal, 20-way, assembly ... .. (For breakdown see DHS. Data Sheet)	1	—	—	EBE1
14987	10-20 N 8231	<b>PILLAR</b> , fixing, 4 BA ... ..	2	—	C	EBE3
28W/9419474	SP.15/B	<b>WASHER</b> ... ..	2	—	C	
	10-20 N 9/162 Mk. 1	<b>CABLE</b> , coded "6.E.FA.GWA-GWA.FB.F.13," assembly	1	—	ECC	EBE1
	10-20 N 9/162 Mk. 5	<b>CABLE</b> , coded "4.W.FA.GWB-GWB.RZ.A," assembly	1	—	ECC	EBE1
	10-20 N 9/162 Mk. 8	<b>CABLE</b> , coded "C.B.RP.GWB-GWB.FA.D.8," assembly	1	—	ECC	EBE1
	10-20 N 9/162 Mk. 14	<b>CABLE</b> , coded "7.E.FA.GWC-GWC.RP.A.A," assembly	1	—	ECC	EBE1
	10-20 N 9/162 Mk. 15	<b>CABLE</b> , coded "B.A.RP.GWC-GWC.FA.D.9," assembly	1	—	ECC	EBE1
	10-20 N 9/162 Mk. 16	<b>CABLE</b> , coded "7.E.FA.GWC-GWC.FB.B.8," assembly	1	—	ECC	EBE1
	10-20 N 9/162 Mk. 17	<b>CABLE</b> , coded "13.G.FB.GWC-GWC.FA.D.9," assembly	1	—	ECC	EBE1
	10-20 N 9/162 Mk. 21	<b>CABLE</b> , coded "2.W.FA.GWA-GWA.PT.A," assembly	1	—	ECC	EBE1
	10-20 N 13521A/ CABLES	<b>CABLE</b> , link, coded "W6-B7" ... ..	1	—	ECC	EBE1
	—	<b>INSTALLATION AT PORT INNER WING</b> ... .. (Drg. Nos. 10-20 N 2399, 10-20 N 11211, 10-20 N 11609 and 10-20 WF 17)	1	—	—	
	— DHS.456/20L	<b>BLOCK</b> , terminal, coded "PZ," group ... ..	1	—	—	
		<b>BLOCK</b> , terminal, 20-way, assembly ... .. (For breakdown see DHS. Data Sheet)	1	—	—	EBE1
5X/9149643	PLESSEY CZ.25111	<b>COVER</b> , terminal block ... ..	1	—	C	
5X/9450403	PLESSEY Z.28426	<b>PILLAR</b> , fixing, 4 BA ... ..	2	—	C	EBE3
	10-20 N 9851A	<b>PLATE</b> , adapter, assembly ... ..	1	—	—	EBE2
	10-20 N 10023ND	<b>CHANNEL</b> , 18 SWG ... ..	1	L.72	LM	EBE2
	10-20 N 7187ND	<b>PLATE</b> , 18 SWG ... ..	1	L.72	LM	EBE2
		Attachments for 10-20 N 9851, Plate :—				
28M/10287	AGS.2001/B/t	Nut, 4 BA ... ..	2	—	C	
28S/14005	A32/B14	Screw, 4 BA ... ..	2	—	C	
	10-20 N 9/162 Mk. 32	<b>CABLE</b> , coded "C.RN.GWB-GWB.RR.A.2," assembly (Mod. 1454)	1	—	ECC	EBE1
	10-20 N 9/162 Mk. 29	<b>CABLE</b> , coded "3.A.RR.GWB-GWB.RQ.A," assembly (Mod. 1454)	1	—	ECC	EBE1

**ELECTRICAL INSTALLATIONS  
WING-FOLD, RADOME AND NAVIGATOR'S HATCH  
LOCKING AND INDICATION, CODED "GW"**

Ref. No.	Part No.	Description						No. off	Material Specification	Class of Store or L.M.	Plate No.
		1	2	3	4	5	6				
	10-20 N 9/162 Mk. 22	<b>CABLE,</b> coded "C.PT.GWA-GWA.PZ.12," assembly						1	—	ECC	EBE1
	10-20 N 9/162 Mk. 24	<b>CABLE,</b> coded "C.RZ.GWB-GWB.RN.A," assembly						1	—	ECC	EBE1
	10-20 N 9/162 Mk. 25	<b>CABLE,</b> coded "A.B.RP.GWB-GWB.RQ.C," assembly						1	—	ECC	EBE1
	10-20 N 13895A	<b>CABLE,</b> coded "SH1," assembly ... (For cables circuit coded "GW")						1	—	ECC	EBE1
5CW/9438275	—	<b>SWITCH,</b> micro, coded "PT," assembly						1	—	P	EBE1
	10-20 WF 967	Attachments for Ref. No. 5CW/9438275, Switch :- Block, packing ...						1	LFS.21, 23 or 26	LM	EBE3
28D/9015170	A25/16B	Bolt, 4 BA ...						2	—	C	
28W/9419465	SP.13/B	Washer ...						2	—	C	
5CW/9438275	—	<b>SWITCH,</b> micro, forward latch pin, coded "RN," assembly						1	—	P	EBE1
		Attachments for Ref. No. 5CW/9438275, Switch :-									
28D/9132448	A25/12B	Bolt, 4 BA ...						1	—	C	
28D/1011013	A25/13B	Bolt, 4 BA ...						1	—	C	
28E/9000882	AS.3180/7B	Clip, "P" ...						1	—	C	
28M/10287	AGS.2001/B/1	Nut, 4 BA ...						2	—	C	
17324	10-20 WC 40715ND	Washer, zinc ".005—.008 thick (Mod. 1134) ...						2	—	C	
5CW/9438275	—	<b>SWITCH,</b> micro, coded "RQ," assembly						1	—	P	EBE1
		Attachments for Ref. No. 5CW/9438275 Switch :-									
28D/1010142	A25/9B	Bolt, 4 BA ...						1	—	C	
28D/9435711	A25/10B	Bolt, 4 BA ...						1	—	C	
28E/9000882	AS.3180/7B	Clip, "P" ...						1	—	C	
28M/10287	AGS.2001/B/1	Nut, 4 BA ...						2	—	C	
28W/1206041	AGS.2035/B	Washer, shakeproof ...						2	—	C	
5CW/9438275	—	<b>SWITCH,</b> micro, coded "RZ," assembly						1	—	P	EBE1
		Attachments for Ref. No. 5CW/9438275, Switch :-									
28D/1011011	A25/8B	Bolt, 4 BA ...						1	—	C	
28D/1010142	A25/9B	Bolt, 4 BA ...						1	—	C	
28E/9436947	AS.3180/4B	Clip, "P" ...						1	—	C	
28M/10287	AGS.2001/B/1	Nut, 4 BA ...						2	—	C	
28W/1206041	AGS.2035/B	Washer, shakeproof ...						1	—	C	
	—	<b>SWITCH,</b> micro, coded "RPA" and "RPB," group						1	—	—	
28E/1200546	AS.3180/5C	CLIP, "P" ...						1	—	C	
		Attachments for AS.3180/5C, Clip :-									
28D/7002428	A25/6C	Bolt, 2 BA ...						1	—	C	
28M/10328	AGS.2002/C/1	Nut, 2 BA ...						1	—	C	
17321	10-20 WC 40713ND	Washer, zinc ".005—.008 thick (Mod. 1134) ...						1	—	C	
	10-20 WC 5677	<b>PLATE,</b> mounting ...						1	L.72	LM	EBE2
		Attachments for 10-20 WC 5677, Plate :-									
28D/9133013	A25/5C	Bolt, 2 BA ...						2	—	C	
28M/10328	AGS.2002/C/1	Nut, 2 BA ...						2	—	C	
28W/9419475	SP.15/C	Washer ...						2	—	C	
17321	10-20 WC 40713ND	Washer, zinc ".005—.008 thick (Mod. 1134) ...						2	—	C	

**ELECTRICAL INSTALLATIONS**  
**WING-FOLD, RADOME AND NAVIGATOR'S HATCH**  
**LOCKING AND INDICATION, CODED "GW"**

Ref. No.	Part No.	Description						No. off	Material Specification	Class of Store or L.M	Place No.
		1	2	3	4	5	6				
5CW/9438275	—	<b>SWITCH</b> , micro ... ..						2	—	P	EBE1
28D/13185	A25/17B	Attachments for Ref. No. 5CW/9438275, Switch :—						2	—	C	
28M/10287	AGS.2001/B/1	Bolt, 4 BA ... ..						2	—	C	
28W/9419401	SP.10/B	Nut, 4 BA ... ..						2	—	C	
		Washer ... ..						2	—	C	
5CW/9108	—	<b>SWITCH</b> , micro, wing latch pin at rib No. 4, coded " RRA," assembly (Mod. 1454)						1	—	P	EBE1
28D/12934	A25/28C	Attachments for Ref. No. 5CW/9108, Switch :—						3	—	C	
28M/10288	AGS.2001/C/1	Bolt, 2 BA ... ..						3	—	C	
28W/9419475	SP.15/C	Nut, 2 BA ... ..						3	—	C	
17321	10-20 WC 40713ND	Washer ... ..						3	—	C	
	—	<b>SWITCH</b> , micro, wing latch pin at rib No. 4, coded " RRB " (See sub-section EBY)						—	—	—	
	—	<b>INSTALLATION AT STARBOARD WING DECK PANEL, CODED "FB "</b> (Drg. Nos. 10-20 N 14863A, 10-20 N 11213, 10-20 N 11609 and 10-20 N 2679)						1	—	—	
	DHS.456/20	<b>BLOCK</b> , terminal, 20-way, coded " B," assembly (For breakdown see DHS. Data Sheet)						1	—	—	EBE2
28D/12690	AS.1246/5B	Attachments for DHS.456/20, Block :—						2	—	C	
28W/9419474	SP.15/B	Bolt, 4 BA ... ..						2	—	C	
	—	<b>BLOCK</b> , terminal, coded " F," group ... ..						1	—	—	
	DHS.456/20	<b>BLOCK</b> , terminal, 20-way, assembly ... .. (For breakdown see DHS. Data Sheet)						1	—	—	EBE2
14987	10-20 N 8231	<b>PILLAR</b> , fixing, 4 BA ... ..						2	—	C	
28W/9419474	SP.15/B	<b>WASHER</b> ... ..						2	—	C	
	—	<b>BLOCK</b> , terminal, coded " G," group ... ..						1	—	—	
	DHS.456/20	<b>BLOCK</b> , terminal, 20-way, assembly ... .. (For breakdown see DHS. Data Sheet)						1	—	—	EBE2
28D/12182	AS.1246/6B	<b>BOLT</b> , 4 BA (Mod. 963) ... ..						2	—	C	
5X/9149643	PLESSEY CZ.25111	<b>COVER</b> , terminal, block (Pre Mod. 963) ... ..						1	—	C	
7657	DHS.870/5	<b>PILLAR</b> , fixing, 4 BA (Pre Mod. 963) ... ..						2	—	C	
26DV/12296	DHS.489/5	<b>SPACER</b> (Pre Mod. 963) ... ..						2	—	C	
28W/9419474	SP.15/B	<b>WASHER</b> ... ..						2	—	C	
	10-20 N 9/162 Mk. 2	<b>CABLE</b> , coded "13.F.FB.GWA—GWA.VT.A," assembly						1	—	ECC	EBE2
	10-20 N 9/162 Mk. 9	<b>CABLE</b> , coded " 7.B.FB.GWB—GWB.WZ.A," assembly						1	—	ECC	EBE2
	10-20 N 9/162 Mk. 12	<b>CABLE</b> , coded " C.B.WP.GWB—GWB.FB.G.12," assembly						1	—	ECC	EBE2
	10-20 N 9/162 Mk. 18	<b>CABLE</b> , coded " 8.B.FB.GWC—GWC.WP.A.A," assembly						1	—	ECC	EBE2

**ELECTRICAL INSTALLATIONS  
WING-FOLD, RADOME AND NAVIGATOR'S HATCH  
LOCKING AND INDICATION, CODED "GW"**

Ref. No.	Part No.	Description	No. off	Material Specification	Class of Score or L.M	Plate No.
	10-20 N 9/162 Mk. 19	<b>CABLE</b> , coded "13.G.FB.GWC—GWC.WP.A.B," assembly	1	—	ECC	EBE2
	10-20 N 8993A	<b>CABLE</b> , coded "VM1," assembly ... (For cable circuit coded "GW")	1	—	ECC	EBE2
	—	<b>INSTALLATION AT STARBOARD INNER WING</b> (Drg. Nos. 10-20 N 11609, 10-20 N 11213, 10-20 N 2679 and 10-20 WF 17)	1	—	—	—
	DHS.456/20	<b>BLOCK</b> , terminal, 20-way, coded "VH," assembly (For breakdown see DHS. Data Sheet)	1	—	—	EBE2
28D/12690	AS.1246/5B	Attachments for DHS.456/20, Block :— Bolt, 4 BA ... ..	2	—	C	—
	10-20 N 9/162 Mk. 30	<b>CABLE</b> , coded "C.WN.GWB—GWB.WR.A.2," assembly (Mod. 1454)	1	—	ECC	EBE2
	10-20 N 9/162 Mk. 31	<b>CABLE</b> , coded "3.A.WR.GWB—GWB.WQ.A," assembly (Mod. 1454)	1	—	ECC	EBE2
	10-20 N 9/162 Mk. 23	<b>CABLE</b> , coded "C.VT.GWA—GWA.VH.1," assembly	1	—	ECC	EBE2
	10-20 N 9/162 Mk. 26	<b>CABLE</b> , coded "C.WZ.GWB—GWB.WN.A," assembly	1	—	ECC	EBE2
	10-20 N 9/162 Mk. 27	<b>CABLE</b> , coded "A.B.WP.GWB—GWB.WQ.C," assembly	1	—	ECC	EBE2
	10-20 N 8993A	<b>CABLE</b> , coded "VM1," assembly ... (For cables circuit coded "GW")	1	—	ECC	EBE2
5CW/9438275	—	<b>SWITCH</b> , micro, coded "VT," assembly Attachments for Ref. No. 5CW/9438275, Switch :—	1	—	P	EBE2
28D/9015170	A25/16B	Bolt, 4 BA ... ..	2	—	C	—
	10-20 WF 967	Block, packing ... ..	1	LFS.21, 23 or 26	LM	EBE3
28W/9419465	SP.13/B	Washer ... ..	2	—	C	—
5CW/9438275	—	<b>SWITCH</b> , micro, forward latch pin, coded "WN," assembly Attachments for Ref. No. 5CW/9438275, Switch :—	1	—	P	EBE2
28D/9132448	A25/12B	Bolt, 4 BA ... ..	1	—	C	—
28D/1011013	A25/13B	Bolt, 4 BA ... ..	1	—	C	—
28E/9000882	AS.3180/7B	Clip, "P" ... ..	1	—	C	—
28M/10287	AGS.2001/B/1	Nut, 4 BA ... ..	2	—	C	—
	17324	Washer, zinc, "005—"008 thick (Mod. 1134) ...	2	—	C	—
5CW/9438275	—	<b>SWITCH</b> , micro, coded "WQ," assembly Attachments for Ref. No. 5CW/9438275, Switch :—	1	—	P	EBE2
28D/1010142	A25/9B	Bolt, 4 BA ... ..	1	—	C	—
28D/9435711	A25/10B	Bolt, 4 BA ... ..	1	—	C	—
28E/9000882	AS.3180/7B	Clip, "P" ... ..	1	—	C	—
28M/10287	AGS.2001/B/1	Nut, 4 BA ... ..	2	—	C	—
28W/1206041	AGS.2035/B	Washer, shakeproof ... ..	2	—	C	—

**ELECTRICAL INSTALLATIONS  
WING-FOLD, RADOME AND NAVIGATOR'S HATCH  
LOCKING AND INDICATION, CODED "GW"**

Ref. No.	Part No.	Description	No. off	Material Specification	Class of Store or L.M	Plate No.
5CW/9438275	—	<b>SWITCH</b> , micro, coded "WZ," assembly ...	1	—	P	EBE2
		Attachments for Ref. No. 5CW/9438275, Switch :—				
28D/1011011	A25/8B	Bolt, 4 BA ...	1	—	C	
28D/1010142	A25/9B	Bolt, 4 BA ...	1	—	C	
28E/9436947	AS.3180/4B	Clip, "P" ...	1	—	C	
28M/10287	AGS.2001/B/1	Nut, 4 BA ...	2	—	C	
28W/1206041	AGS.2035/B	Washer, shakeproof ...	1	—	C	
	—	<b>SWITCHES</b> , micro, coded "WPA" and "WPB," group	1	—	—	
28E/8018279	AS.3180/4C	<b>CLIP</b> , "P" ...	1	—	C	
		Attachments for AS.3180/4C, Clip :—				
28D/7002428	A25/6C	Bolt, 2 BA ...	1	—	C	
28M/10328	AGS.2002/C/1	Nut, 2 BA ...	1	—	C	
17321	10-20 WC 40713ND	Washer, zinc, ".005—.008 thick (Mod. 1134)	1	—	C	
	10-20 WC 5677	<b>PLATE</b> , mounting ...	1	L.72	LM	EBE2
		Attachments for 10-20 WC 5677, Plate :—				
28D/9133013	A25/5C	Bolt, 2 BA ...	2	—	C	
28M/10328	AGS.2002/C/1	Nut, 2 BA ...	2	—	C	
28W/9419475	SP.15/C	Washer ...	2	—	C	
17321	10-20 WC 40713ND	Washer, zinc, ".005—.008 thick (Mod. 1134)	2	—	C	
5CW/9438275	—	<b>SWITCH</b> , micro ...	2	—	P	EBE2
		Attachments for Ref. No. 5CW/9438275, Switch :—				
28D/9015170	A25/16B	Bolt, 4 BA (Pre Mod. 2) ...	2	—	C	
28D/13185	A25/17B	Bolt, 4 BA (Mod. 2) ...	2	—	C	
28M/10287	AGS.2001/B/1	Nut, 4 BA ...	2	—	C	
28W/9419401	SP.10/B	Washer ...	2	—	C	
5CW/9108	—	<b>SWITCH</b> , micro, coded "WRA," assembly (Mod. 1454)	1	—	P	EBE2
		Attachments for Ref. No. 5CW/9108, Switch :—				
28D/1011025	A25/24C	Bolt, 2 BA (Pre Mod. 2) ...	3	—	C	
28D/1011019	A25/8C	Bolt, 2 BA (Mod. 2) ...	3	—	C	
28M/10328	AGS.2002/C/1	Nut, 2 BA (Pre Mod. 2) ...	3	—	C	
28M/10288	AGS.2001/C/1	Nut, 2 BA (Mod. 2) ...	3	—	C	
28W/9419475	SP.15/C	Washer ...	3	—	C	
17321	10-20 WC 40713ND	Washer, zinc, ".005—.008 thick (Mod. 1134) ...	3	—	C	
	—	<b>INSTALLATION AT WING-FOLD, STARBOARD</b> (Drg. No. 10-20 N 11513)	1	—	—	
	10-20 N 8995A	<b>CABLE</b> , coded "VM1-XH1," assembly ...	1	—	ECC	EBE2

**ELECTRICAL INSTALLATIONS  
WING-FOLD, RADOME AND NAVIGATOR'S HATCH  
LOCKING AND INDICATION, CODED "GW"**

Ref. No.	Part No.	Description	No. off	Material Specification	Class of Score or L.M.	Plate No.
		<b>INSTALLATION AT OUTER WING, PORT AND STARBOARD</b> (Drg. Nos. 10-20 N 11509 and 10-20 N 11511)	1	—	—	
	10-20 N 8979A	<b>CABLE</b> , Port, coded "SH1," assembly ... (For cables circuit coded "GW")	1	—	ECC	EBE2
	10-20 N 8997A	<b>CABLE</b> , Starboard, coded "XH1," assembly (Mod. 2) (For cables circuit coded "GW")	1	—	ECC	EBE2
28E/9436947	AS.3180/4B	<b>CLIP</b> , "P" ...	8	—	C	
		Attachments for AS.3180/4B, Clip:—				
28M/10287	AGS.2001/B/1	Nut, 4 BA ...	1	—	C	
28S/14005	A32/B14	Screw, 4 BA ...	1	—	C	
5K/2906	SP.40/E10	<b>GROMMET</b> ...	2	—	C	
	10-20 N 2735A	<b>SWITCH</b> , micro, Port, coded "SV," assembly	1	—	—	EBE2
	10-20 N 2736A	<b>SWITCH</b> , micro, Starboard, coded "XV," assembly	1	—	—	EBE2
28M/9434251	AGS.2008/B/1	<b>NUT</b> , 4 BA, double anchor ...	1	—	C	
28M/13774	AGS.2019/B/1	<b>NUT</b> , 4 BA, single anchor ...	1	—	C	
	9280	<b>PLATE</b> , mounting, Port, only, 14 SWG ...	1	—	C	EBE2
	10-20 WC 11171ND	<b>PLATE</b> , mounting, Starboard only, 14 SWG	1	L.72	LM	EBE2
	10-20 WC 11172ND	<b>SWITCH</b> , micro ...	1	—	P	EBE2
5CW/4639	—	Attachments for Ref. No. 5CW/4639, Switch:—				
28D/9130080	AS.1242/9B	Bolt, 4 BA ...	2	—	C	
28M/10327	AGS.2002/B/1	Nut, 4 BA ...	2	—	C	
	10-20 N 2737ND	Packing, 16 SWG	1	L.72	LM	EBE2
		Attachments for 10-20 N 2735A or 10-20 N 2736A, Switch:—				
28D/1007979	AS.1246/1B	Bolt, 4 BA ...	1	—	C	
28D/9130082	AS.1246/3B	Bolt, 4 BA ...	1	—	C	
	3564	Washer, serrated ...	1	—	C	EBE3
5F/9434858	—	<b>STRAP</b> , flexible, cable fastening, $\frac{5}{16}$ " wide ...	QR	P.V.C.	C	
5F/2280	—	<b>STUD</b> , cable fastening strap ...	QR	Nylon	C	
32B/—	—	<b>TAPE</b> , identification numbers and letters, use from Ref. Nos. 32B/1087 to 32B/1120 inclusive, as required	QR	—	C	
14370	DHS.181/12	<b>TUBING</b> , cable sheathing, 12 m/m i/d ...	QR	P.V.C.	C	
14371	DHS.181/13	<b>TUBING</b> , cable sheathing, 13 m/m i/d ...	QR	P.V.C.	C	

**EBE.1**  
**ELECTRICAL INSTALLATION**  
**WING-FOLD, RADOME AND NAVIGATORS HATCH**  
**LOCKING AND INDICATION**  
**CODED GW**  
**RESTRICTED**

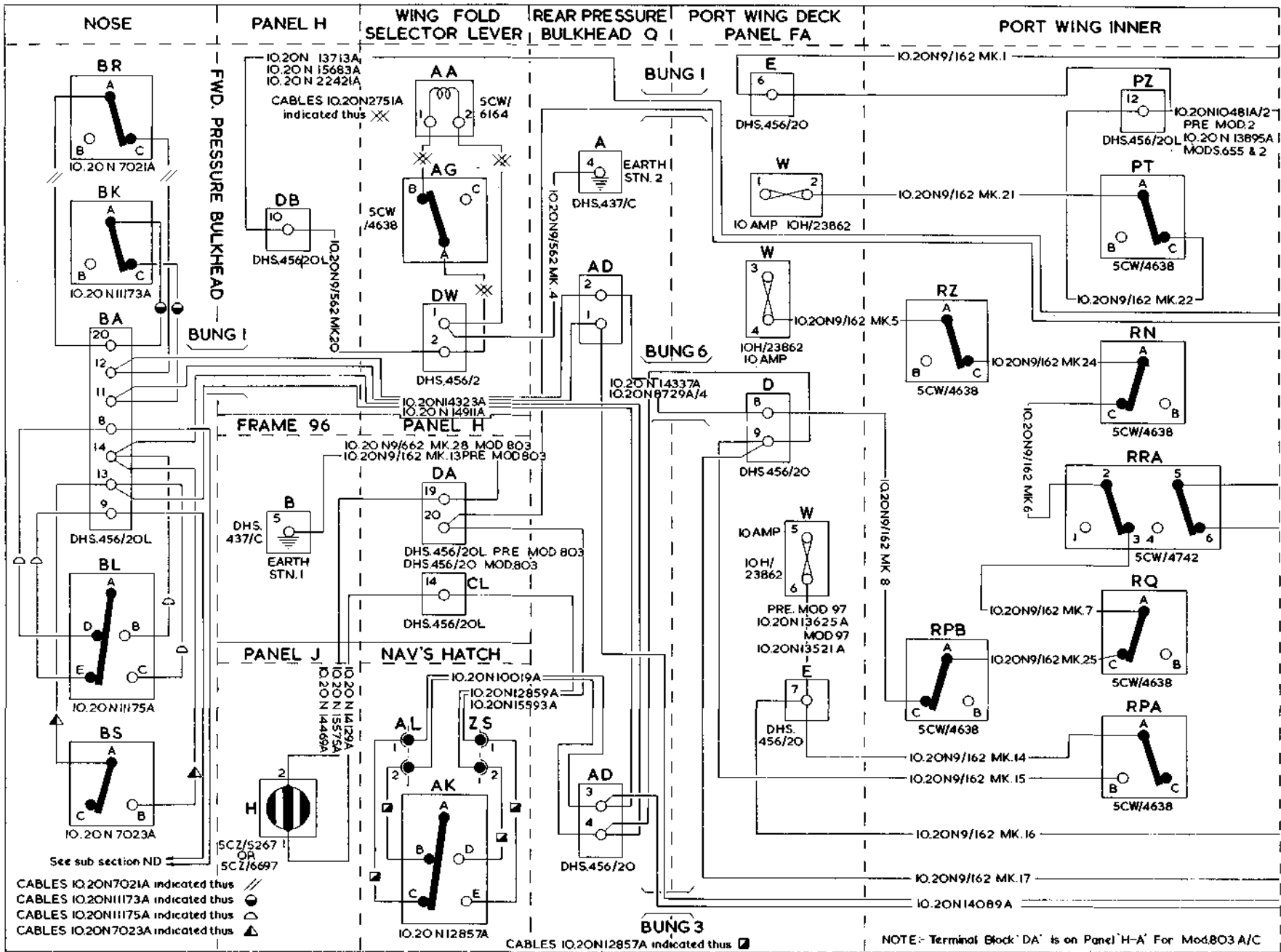

CABLES IO.20N7021A indicated thus   
 CABLES IO.20N1173A indicated thus   
 CABLES IO.20N1175A indicated thus   
 CABLES IO.20N7023A indicated thus

CABLES IO.20N12857A indicated thus

NOTE:- Terminal Block 'DA' is on Panel 'H-A' For Mod.803 A/C

Sea Vixen Mk. 1

RESTRICTED

Plate EBE.1

**EBE.2**  
**ELECTRICAL INSTALLATION**  
**WING FOLD, RADOME AND NAVIGATORS HATCH**  
**LOCKING AND INDICATION**  
**CODED GW**  
**RESTRICTED**

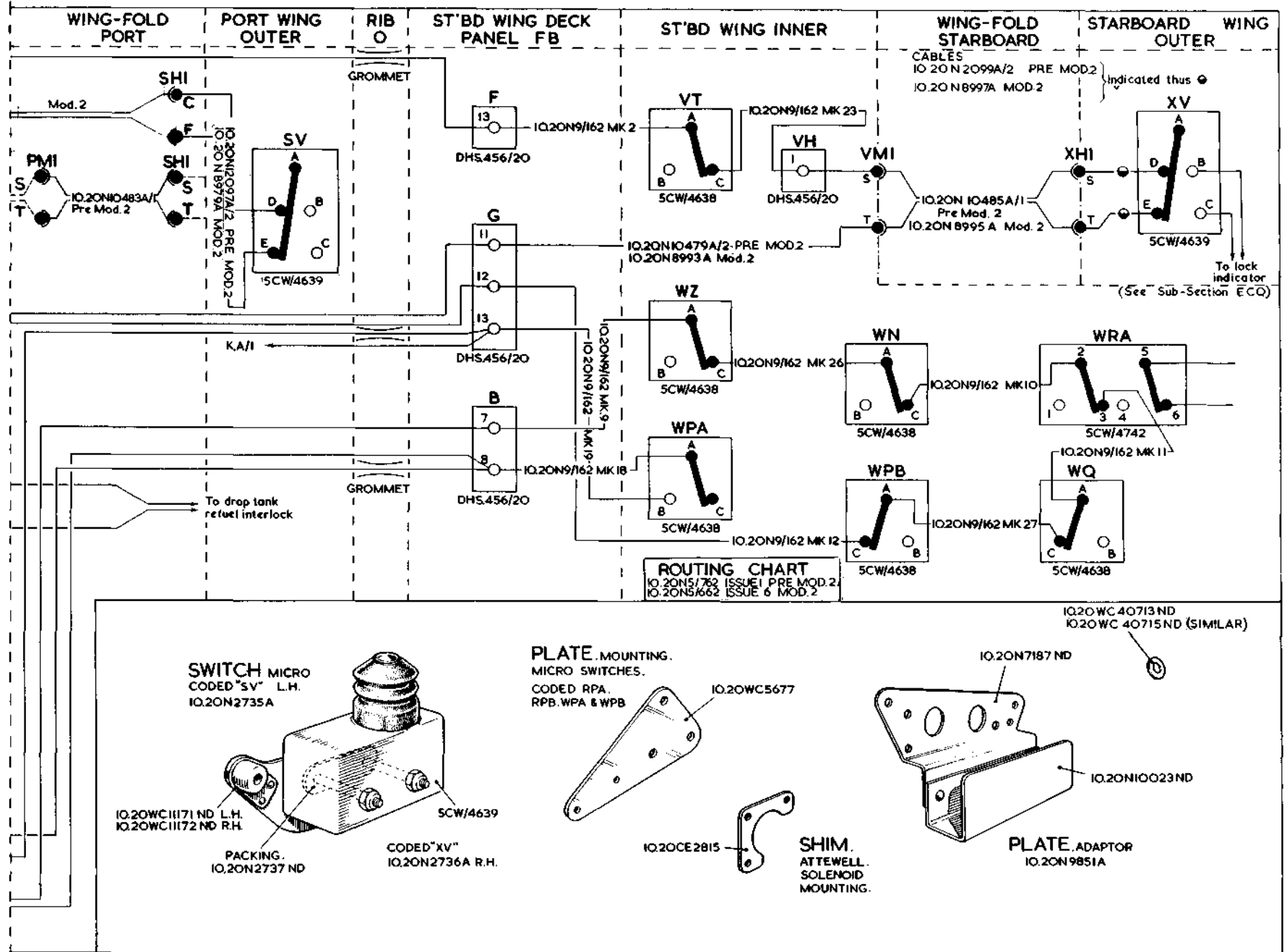

See Vixen Mk. 1

Plate EBE 2

PIECE, DISTANCE  
IO.20 N 7159

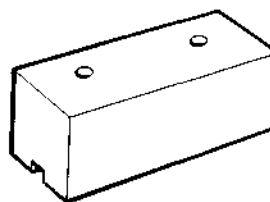
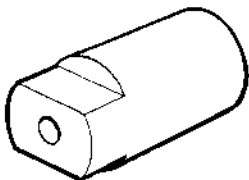

BLOCK, PACKING  
IO.20 WF 967

DHS.870/1  
SIMILAR  
DHS.870/5



WASHER, SERRATED  
IO.WC 11163



SPACER  
DHS.489/5

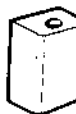

PILLAR, FIXING  
IO.20 N 8231

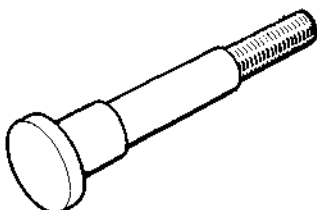
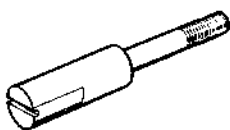

PIN  
IO.20 FS 13839

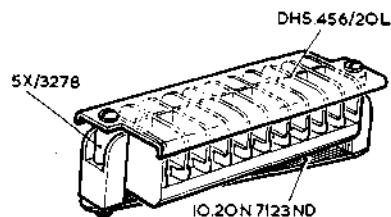

PLATE, MOUNTING, C/W T/B ASSEMBLY  
IO.20 N 7121A

COVER, MICRO SWITCH  
IO.20 FS 13845

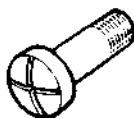
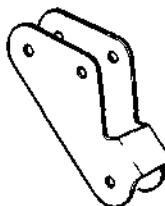

SCREW  
DHS.849

SPRING  
IO.20 FS 13843

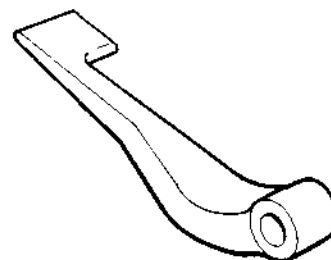

LEVER  
IO.20 FS 13841

EBE.3

# ELECTRICAL INSTALLATION

WING-FOLD, RADOME AND NAVIGATOR'S HATCH  
LOCKING AND INDICATION CODED GW

EBE.3  
[A.L.43]



This file was downloaded  
from the RTFM Library.

Link: [www.scottbouch.com/rtfm](http://www.scottbouch.com/rtfm)

Please see site for usage terms,  
and more aircraft documents.