

ELECTRICAL INSTALLATIONS
INSTALLATION OF T.A.C.A.N. SUPPLY, CODED "RH"

Ref. No.	Part No.	Description	No. off	Material Specification	Class of Score or L.M.	Plate No.
	—	INSTALLATION OF T.A.C.A.N. SUPPLY, CODED "RH"	1	—	—	
	—	INSTALLATION AT PANEL, CODED "H" (Drg. Nos. 10-20 N 15781, 10-20 N 22229, 10-20 N 15883A, 10-20 N 15709A and 10-20 N 11421)	1	—	—	
10H/23862	—	BLOCKS , fuse, coded "CU" and "CV," group	1	—	—	
	—	BLOCK , fuse, 12-way (See sub-section EBV) ...	—	—	—	
	—	FUSE , 10 amp. ...	2	—	C	ECA1
	—	BLOCK , terminal, coded "CN," group ...	1	—	—	
	DHS.456/5L	BLOCK , terminal, 5-way, assembly ... (For breakdown see DHS. Data Sheet)	1	—	—	ECA1
5X/9149641	PLESSEY CZ.26805	COVER , terminal block ...	1	—	C	
12732	10-20 N 8085	PILLAR , fixing, 4 BA ...	2	—	C	ECA1
	—	BLOCK , terminal, coded "CR," group ...	1	—	—	
	DHS.456/20L	BLOCK , terminal, 20-way, assembly ... (For breakdown see DHS. Data Sheet)	1	—	LM	ECA1
5X/9149643	PLESSEY CZ.25111	COVER , terminal block ...	1	—	C	
12732	10-20 N 8085	PILLAR , fixing, 4 BA ...	2	—	C	
	10-20 N 9/571 Mk. 10	CABLE , coded "16.CV.H.RHB-RHB.T.B.1," assembly	1	—	ECC	ECA1
	10-20 N 9/571 Mk. 11	CABLE , coded "14.CU.H.RHA-RHA.T.B.3," assembly	1	—	ECC	ECA1
	10-20 N 13415/CABLES	CABLES , circuit coded "RH" (Mod. 332, (Pre Mod. 416)	3	—	ECC	ECA1
	10-20 N 15771/CABLES	CABLES , circuit coded "RH" (Mod. 702, (Pre Mod. 803)	3	—	ECC	ECA1
	10-20 N 22251/CABLES	CABLES , circuit coded "RH" (Mods. 1016 and 803)	3	—	ECC	ECA1
	—	INSTALLATION AT RELAY GROUP, CODED "T" (Drg. Nos. 10-20 N 11421 and 10-20 N 5733)	1	—	—	
	10-20 N 9/571 Mk. 5	CABLE , coded "1.H.T.RH-RH.Q.AE.11," assembly	1	—	ECC	ECA1
	10-20 N 9/571 Mk. 6	CABLE , coded "2.H.T.RH-RH.*2.A.8," assembly	1	—	ECC	ECA1
	10-20 N 9/571 Mk. 12	CABLE , coded "2.B.T.RH-RH.T.H.2," assembly	1	—	ECC	ECA1
	10-20 N 9/571 Mk. 13	CABLE , coded "1.B.T.RHB-RHB.T.H.3," assembly	1	—	ECC	ECA1
	10-20 N 9/571 Mk. 14	CABLE , coded "4.B.T.RHA-RHA.Q.AE.8," assembly	1	—	ECC	ECA1
	10-20 N 9/571 Mk. 16	CABLE , coded "4.H.T.RHB-RHB.Q.AA.10," assembly	1	—	ECC	ECA1
	10-20 N 15383A	CABLE , coded "T," assembly (Mod. 898) ... (For cables circuit coded "RH")	QR	—	ECC	ECA1
5CW/6452	—	SWITCH , magnetic, Type 9B, No. 1A, coded "B" and "H"	2	—	P	ECA1
		Attachments for Ref. No. 5CW/6452, Switch:—				
28M/10327	AGS.2002/B/1	Nut, 4 BA ...	2	—	C	
28S/1008085	A32/B32	Screw, 4 BA ...	2	—	C	
28W/9419465	SP.13/B	Washer ...	4	—	C	

ELECTRICAL INSTALLATIONS

INSTALLATION OF T.A.C.A.N. SUPPLY, CODED "RH"

Ref. No.	Part No.	Description	No. off	Material Specification	Class of Store or L.M.	Plate No.
	—	INSTALLATION AT REAR PRESSURE BULK-HEAD, CODED "Q" (Drg. Nos. 10-20 N 10635 and 10-20 N 11421)	1	—	—	
	—	BLOCK, terminal, coded "AA," group ...	1	—	—	ECA1
	DHS.456/20	BLOCK, terminal, 20-way, assembly ... (For breakdown see DHS. Data Sheet)	1	—	—	
5X/9149643	PLESSEY CZ.25111	COVER, terminal block ...	1	—	C	
12732	10-20 N 805	PILLAR, fixing, 4 BA ...	2	—	C	
5195	DHS.849	SCREW (Fit to terminal 7) ...	1	—	C	
	—	BLOCK, terminal, coded "AE," group ...	1	—	—	ECA1
	DHS.456/20	BLOCK, terminal, 20-way, assembly ... (For breakdown see DHS. Data Sheet)	1	—	—	
5X/9149643	PLESSEY CZ.25111	COVER, terminal block ...	1	—	C	
5X/1004082	PLESSEY Z.50210	LINK, commoning, terminals 9-10 ...	1	—	C	
16671	DHS.870/1	PILLAR, fixing, 4 BA ...	2	—	C	
5195	DHS.849	SCREW (Fit to terminal 12) ...	1	—	C	
28W/9419401	SP.10/B	WASHER (Fit under outboard foot of terminal block)	2	—	C	
	10-20 N 9/571 Mk. 3	CABLE, coded "12.AE.Q.RH-RH.★2.A.7," assembly	1	—	ECC	ECA1
	10-20 N 9/571 Mk. 9	CABLE, coded "11.AA.Q.RH-RH.★3.D.3," assembly	1	—	ECC	ECA1
	—	TERMINAL, earth, station 2, coded "A," group	1	—	—	
28M/10288	AGS.2001/C/1	NUT, 2 BA ...	2	—	C	
26DV/7529	DHS.438/C	TAG, corrosion ...	1	—	C	
26DV/4969	DHS.437/C	TERMINAL, earth, assembly ... (For breakdown see DHS. Data Sheet)	1	—	C	ECA1
28W/9419475	SP.15/C	WASHER ...	2	—	C	
	—	TERMINAL, earth, station 3, coded "D," group	1	—	—	
28M/10288	AGS.2001/C/1	NUT, 2 BA ...	2	—	C	
26DV/4969	DHS.437/C	TERMINAL, earth, assembly ... (For breakdown see DHS. Data Sheet)	1	—	C	ECA1
28W/9419475	SP.15/C	WASHER ...	2	—	C	
32B/—	—	TAPE, identification, numbers and letters, use from Ref. Nos. 32B/107 to 32B/1120 inclusive, as required	QR	—	C	

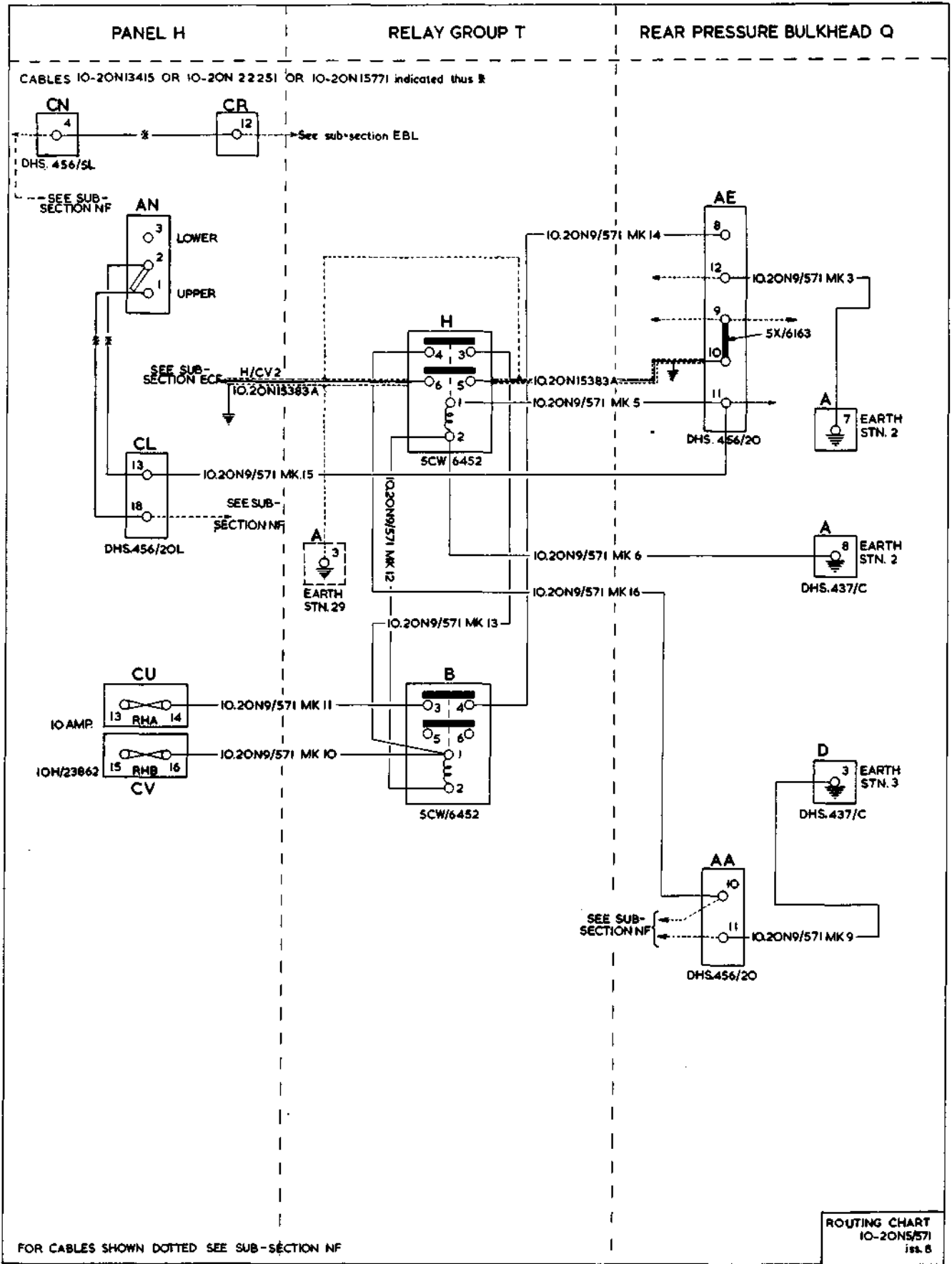

ECA. I

ELECTRICAL INSTALLATION

TACAN SUPPLY

CODED RH

ECA. I

[A.L.43]



This file was downloaded
from the RTFM Library.

Link: www.scottbouch.com/rtfm

Please see site for usage terms,
and more aircraft documents.