

**ELECTRICAL INSTALLATIONS**

**INSTALLATION OF AUTO-THROTTLE, CODED "KT"**

Ref. No.	Part No.	Description	No. off	Material Specification	Class of Store or L.M.	Place No.
	—	<b>INSTALLATION OF AUTO-THROTTLE, CODED "KT" (Mod. 1101)</b>	1	—	—	
	—	<b>INSTALLATION IN COCKPIT (Drg. Nos. 10-20 CE 4429A, 10-20 CE 4643A, 10-20 CE 8117A, 10-20 N 11421, 10-20 N 11713, 10-20 N 13463, 10-20 N 23407A and 10-20 N 23973)</b>	1	—	—	
6TE/4449	ELLIOT BROS. 3D1056	<b>AMPLIFIER</b> , throttle servo, coded "AFT," group	1	—	—	ECX1
6TE/—	ELLIOT BROS. 3D1056-A1 OR 3D1056-A2	<b>AMPLIFIER</b> , throttle servo (Pre Mod. 1467)	1	—	—	ECX1
	—	<b>AMPLIFIER</b> , throttle servo (Mod. 1467) ...	1	—	—	ECX1
	ELLIOT BROS. 3C462	<b>AMPLIFIER</b> , throttle servo (Special order only) (Mod. 1586)	1	—	—	ECX1
28DU/1212034	A102/10C	<b>TRAY</b> , amplifier mounting ...	1	—	—	ECX1
28DU/1212035	A102/11C	Attachments for 3C462, Tray:—	1	—	—	
28M/9438421	A125/C	Bolt, No. 8 UNC ...	3	—	C	
	10-20 F 8243	Bolt, No. 8 UNC ...	1	—	C	
	10-20 F 8245	Nut, No. 8 UNC ...	4	—	C	
28W/9156626	SP.122°C	Spacer, aft, 0"-35 long ...	2	L.64	LM	ECX1
	—	Spacer, forward, 0"-40 long ...	2	L.64	LM	ECX1
	—	Washer, packing ...	4	—	C	
	DHS.456/20	<b>BLOCK</b> , terminal, coded "B," group ...	1	—	—	
	—	<b>BLOCK</b> , terminal, 20-way, assembly ... (For breakdown see DHS. Data Sheet)	1	—	—	
5X/9149643	PLESSEY CZ.25111	<b>BRACKET</b> , mounting (See sub-section KQ)	—	—	—	
12732	10-20 N 8085	<b>COVER</b> , terminal block (5940-99-914-9643)	1	—	C	BA13
	—	<b>PILLAR</b> , fixing, 4 BA ...	2	—	C	EBG1
	10-20 N 7215A	<b>BLOCK</b> , terminal, coded "C," group ...	1	—	—	
	DHS.456/10L	<b>BLOCK</b> , terminal, assembly ...	1	—	—	
	—	<b>BLOCK</b> , terminal, 10-way, L.H., assembly (For breakdown see DHS. Data Sheet)	1	—	—	
28S/9137407	A43/A8	<b>SCREW</b> , 6 BA } Use in lieu of	1	—	C	
28W/9137412	AGS.2037/A	<b>WASHER</b> , shakeproof } terminal No. 10	1	—	C	
5X/3276	PLESSEY CZ.50205	<b>BLOCK</b> , terminal, 2-way, assembly (Terminals Nos. 11 and 12)	1	—	C	
5X/3272	PLESSEY CZ.26799	<b>COVER</b> , terminal block, 2-way ...	1	—	C	BA13
	10-20 N 7327A	<b>COVER</b> , terminal block, 10-way (Make from Ref. No. 5X/3275)	1	—	LM	BA13
5X/9450403	PLESSEY Z.28426	<b>PILLAR</b> , fixing, 4 BA (5340-99-945-0403) ...	4	—	C	EBG1
	—	<b>BLOCK</b> , terminal, coded "E," group ...	1	—	—	
	DHS.456/20L	<b>BLOCK</b> , terminal, 20-way, L.H., assembly (For breakdown see DHS. Data Sheet)	1	—	—	
	—	<b>BRACKET</b> , mounting (See sub-section KQ)	—	—	—	
5X/9149643	PLESSEY CZ.25111	<b>COVER</b> , terminal block (5940-99-914-9643)...	1	—	C	BA13
12732	10-20 N 8085	<b>PILLAR</b> , fixing, 4 BA ...	2	—	C	EBG1
	—	<b>BLOCK</b> , terminal, coded "J," group ...	1	—	—	
	DHS.456/3	<b>BLOCK</b> , terminal, 3-way, assembly ... (For breakdown see DHS. Data Sheet)	1	—	—	
5X/3273	PLESSEY CZ.26805	<b>COVER</b> , terminal block ...	1	—	C	BA13
5X/1004082	PLESSEY Z.50210	<b>LINK</b> , terminal connecting, 2-way (Fit between terminals Nos. 1 and 2) (5940-99-100-4082)	1	—	C	
5X/9450403	PLESSEY Z.28426	<b>PILLAR</b> , fixing, 4 BA (5340-99-945-0403) ...	2	—	C	EBG1
	—	<b>BLOCK</b> , terminal and relay, group ...	1	—	—	
	—	<b>BLOCK</b> , terminal, 2-way, coded "ACJ" (See sub-section ECP)	—	—	—	
	—	<b>BRACKET</b> , mounting, relay and terminal block (See sub-section ECP)	—	—	—	
	10-22 N 1951A	<b>RELAY</b> , magnetic, c/w cables, coded "ACJ-A," assembly	1	—	—	

ELECTRICAL INSTALLATIONS

INSTALLATION OF AUTO-THROTTLE, CODED "KT"

Ref. No.	Part No.	Description	No. off	Material Specification	Class of Store or L.M.	Plate No.
5945-99-011-9145	10-22 N 1951A/ CABLES ERICSSON 5M5D-N73	<b>CABLES</b> ... .. <b>RELAY</b> , magnetic, Type 2 ... .. Attachments for 10-22 N 1951A, Relay :—	QR 1	—	ECC P	
28D/9137408	AS.1246/1/2 B	Bolt, 4 BA ... ..	2	—	C	
28M/10287	AGS.2001/B/1	Nut, 4 BA ... ..	2	—	C	
28VV/9419401	SP.10/B	Washer ... ..	2	—	C	
	—	<b>BLOCK</b> , terminal, coded "ALG-A," group (Mod. 1428)	1	—	—	
5CZ/7142	WARD BROOKE WB.1110/S/3/B	<b>BLOCK</b> , terminal, 3-way, assembly ... ..	1	—	C	
5CZ/6109	WARD BROOKE WB.1110/3/B	<b>COVER</b> , terminal block ... ..	1	—	C	
20305	10-20 N 24589ND	<b>PILLAR</b> ... ..	2	—	C	
28S/1212705	A40/B10	<b>SCREW</b> , 4 BA ... ..	2	—	C	
28VV/9419474	SP.15/B	<b>WASHER</b> ... ..	2	—	C	
28VV/9416642	SP.47/B	<b>WASHER</b> , spring ... ..	2	—	C	
18964	10-20 N 23337A	<b>BOX</b> , datum, airspeed, c/w equipment, coded "AFS," assembly Spares for :—	1	—	P	ECX1
5CZ/6099	WARD BROOKE WB.1110/S/5	<b>BLOCK</b> , connector, 5-way, coded "A," "B" and "C" Attachments for WB.1110/S/5, Block :—	3	—	C	ECX1
28M/10327	AGS.2002/B/1	Nut, 4 BA ... ..	2	—	C	
28S/1200040	A31/B20	Screw, 4 BA ... ..	2	—	C	
28VV/9419465	SP.13/B	Washer ... ..	2	—	C	
	DHS.456/2	<b>BLOCK</b> , terminal, 2-way, coded "D," assembly (For breakdown see DHS. Data Sheet) Attachments for DHS.456/2, Block :—	1	—	—	ECX1
28M/10327	AGS.2002/B/1	Nut, 4 BA ... ..	2	—	C	
28S/1200033	A31/B24	Screw, 4 BA ... ..	2	—	C	
28VV/9419465	SP.13/B	Washer ... ..	2	—	C	
	10-20 N 23309A	<b>BOX</b> , datum, airspeed, less equipment, assembly Spares for :—	1	—	—	ECX1
	10-20 N 23303	<b>BRACKET</b> , attachment ... ..	4	S.92	—	ECX1
	10-20 N 23315A	<b>FAIRLEAD</b> , complete, assembly ... ..	1	—	—	ECX1
	10-20 N 23327A/ND	<b>FAIRLEAD</b> , bottom, assembly ... ..	1	—	—	ECX1
	10-20 N 23323ND	<b>FAIRLEAD</b> , rubber, shore hardness 60°	1	—	LM	ECX1
	10-20 N 23311ND	<b>PLATE</b> , back, 20 SWG ... ..	1	L.72	LM	ECX1
	10-20 N 23319ND	<b>PLATE</b> , face, 20 SWG ... ..	1	L.72	LM	ECX1
	10-20 N 23329A/ND	<b>FAIRLEAD</b> , top, assembly ... ..	1	—	—	ECX1
	10-20 N 23325ND	<b>FAIRLEAD</b> , rubber, shore hardness 60°	1	—	LM	ECX1
	10-20 N 23313ND	<b>PLATE</b> , back, 20 SWG ... ..	1	—	LM	ECX1
	10-20 N 23321ND	<b>PLATE</b> , face, 20 SWG ... ..	1	—	LM	ECX1
		Attachments for 10-20 N 23315A, Fairlead :—				
28M/10327	AGS.2002/B/1	Nut, 4 BA ... ..	4	—	C	
28S/1008327	A32/B14	Screw, 4 BA ... ..	4	—	C	
28VV/9419465	SP.13/B	Washer ... ..	4	—	C	
	10-20 N 23291A	<b>CHASSIS</b> , datum box, c/w wiring, assembly Spares for :—	1	—	—	ECX1
18967	10-20 N 23289A	<b>BOARD</b> , tag, coded "J," assembly Attachments for 10-20 N 23289A, Board :—	1	—	C	ECX1
28M/10326	AGS.2002/A/1	Nut, 6 BA ... ..	3	—	C	
	10-20 N 24099ND	Packing, 1/16" ... ..	1	LFS.21-23 or 26	LM	ECX1
28S/1200045	A31/A10	Screw, 6 BA ... ..	3	—	C	
28VV/9419464	SP.13/A	Washer ... ..	3	—	C	

**ELECTRICAL INSTALLATIONS**

**INSTALLATION OF AUTO THROTTLE, CODED "KT"**

Ref. No.	Part No.	Description	No. off	Material Specification	Class of Store or L.M	Plate No.
	10-20 N 23303	<b>BRACKET</b> , attachment (Ref. Drg. No. 10-20 N 23281A)	2	S.92	—	ECX1
	10-20 N 23283/ CABLES PLESSEY	<b>CABLES</b> , link ... ..	QR	—	ECC	
5935-99-944-6074	UK-AN(ET)8000-18-1S	<b>CONNECTOR</b> , for cables coded "AFS.1"	1	—	—	
5K/—	SP.95/A8	<b>GROMMET</b> (Alternative DHS.1790/A8) ...	1	—	C	
10F/0119145	ERICSSON 5M5D-N73	<b>RELAY</b> , magnetic, Type 2, coded "E," "F" and "G" (5945-99-011-9145)	3	—	P	
		Attachments for 5M5D-N73, Relay:—				
28M/10327	AGS.9002/B/1	Nut, 4 BA ... ..	2	—	C	
28S/1201448	A31/B10	Screw, 4 BA ... ..	2	—	C	
28W/9419465	SP.13/B	Washer ... ..	2	—	C	
6TE/4452	ELLIOTT BROS. 3C532	<b>TRANSFORMER</b> , coded "H" ... ..	1	—	—	ECX1
		Attachments for 3C532, Transformer:—				
28S/1200043	A31/A18	Screw, 6 BA ... ..	2	—	C	
	10-20 N 21063ND	Spacer, $\frac{3}{16}$ " o/d x 0".37 long ... ..	2	LFB.82 or 89	LM	ECX1
28W/9419464	SP.13/A	Washer ... ..	2	—	C	
	10-20 N 23293A	<b>UNIT</b> , airspeed, sensing c/w mounting plate, assembly	1	—	—	ECX1
	—	<b>PLATE</b> , mounting, group ... ..	1	—	—	
10AJ/—	A.V.A. LTD.A.V.M.106	<b>MOUNTING</b> , "Arctrop" ... ..	4	—	—	ECX1
28M/12619	A24/BT	<b>NUT</b> , 4 BA, locking, arctrop mountings	4	—	C	
18966	10-20 N 23285	<b>PLATE</b> , mounting ... ..	1	—	C	ECX1
28W/1200328	AGS.2037/B	<b>WASHER</b> , under "Arctrop" mountings	4	—	C	
	R. W. MUNRO	<b>UNIT</b> , sensing, airspeed ... ..	1	—	—	ECX1
6TE/—	APO/10A/400/11	Attachments for APO/10A/400/11, Unit:—				
28M/10326	AGS.2002/A/1	Nut, 5 BA ... ..	4	—	C	
28S/9419437	A31/A16	Screw, 6 BA ... ..	4	—	C	
		Attachments for 10-20 N 23293A, Unit:—				
28M/10327	AGS.2002/B/1	Nut, 4 BA ... ..	4	—	C	
28W/9419486	SP.16/B	Washer ... ..	4	—	C	
20987	10-20 X 9363	<b>WASHER</b> ... ..	QR	—	C	
		Attachments for 10-20 N 23291A, Chassis:—				
28S/1011488	A32/B28	Screw, 4 BA ... ..	6	—	C	
5K/—	SP.95/A24	<b>GROMMET</b> (Alternative DHS.1790/A24) ...	1	—	C	
	—	<b>HOSE</b> , flexible, airspeed sensing unit (See sub-section QD)	—	—	—	
	10-20 N 23333A	<b>PLATE</b> , bottom, datum box, assembly ...	1	—	—	ECX1
		Attachments for 10-20 N 23333A, Plate:—				
28S/1200045	A31/A10	Screw, 6 BA ... ..	4	—	C	
18965	10-20 N 23339A	<b>PLATE</b> , top, datum box, assembly ... ..	1	—	C	ECX1
		Spares for:—				
28M/9132600	10-20 N 23341ND	<b>BRACKET</b> , attachment, 18 SWG ... ..	1	L.72	LM	ECX1
15611	AGS.2019/A/1	<b>NUT</b> , anchor, 6 BA ... ..	6	—	C	
	10-20 N 12235	<b>SPIGOT</b> ... ..	2	—	C	ECX1
		Attachments for 10-20 N 12235, Spigot:—				
28M/10287	AGS.2001/B/1	Nut, 4 BA ... ..	1	—	C	
28W/9419465	SP.13/B	Washer ... ..	1	—	C	
		Attachments for 10-20 N 23339A, Plate:—				
28S/1200045	A31/A10	Screw, 6 BA ... ..	6	—	C	

ELECTRICAL INSTALLATIONS

INSTALLATION OF AUTO THROTTLE, CODED "KT"

Ref. No.	Part No.	Description	No of						Material Specification	Class of Store or L.M.	Plate No.
			1	2	3	4	5	6			
5310-99-915-0815	PLESSEY 2Z.139598	<b>WASHER</b> , packing, panel, at connector "AFS-1"						1	—	C	
28D/9436920	A25/1C	Attachments for 10-20 N 23337A, Box :—									
28W/9419402	SP.13/C	Bolt, 2 BA ... ..						2	—	C	
		Washer ... ..						2	—	C	
	10-20 N 22855A	<b>BRACKET</b> , mounting, c/w indicator and lamp, auto-throttle, assembly						1	—	—	ECX2
18968	10-20 N 22851A	<b>BRACKET</b> , mounting, assembly ... ..						1	—	C	ECX2
5CZ/7829	DOWTY C.5175 Y. Mk. 188	<b>INDICATOR</b> , electro magnetic, coded "AHS"						1	—	C	ECX2
	—	<b>LAMP</b> , coded "AHT" (See sub-section EBL)						—	—	—	
19749	10-20 N 24401	<b>WASHER</b> , packing, under indicator ... ..						1	—	C	ECX2
28W/9419402	SP.13/C	<b>WASHER</b> ... ..						1	—	C	
		Attachments for 10-20 N 22855A, Bracket :—									
28D/1218386	AS.1248/3B	Bolt, 4 BA ... ..						2	—	C	
28W/9419465	SP.13/B	Washer ... ..						2	—	C	
	—	<b>BRACKET</b> , test point, M.R.G., U.H.F. and Auto-throttle (See sub-section NH)						—	—	—	
	10-20 N 22737A	<b>CABLE</b> , bung "Q7," coded "FA," assembly ... (Mod. 1042, Pre Mod. 803) (For cables circuit coded "KT")						1	—	ECC	
	10-20 N 22735A	<b>CABLE</b> , bung "Q7," coded "FA," assembly ... (Mods. 1042 and 803) (For cables circuit coded "KT")						1	—	ECC	
	10-20 N 9/791 Mk. 3	<b>CABLE</b> , coded "3.F.J.KT-KT.AFS.A.3," assembly						1	—	ECC	
	10-20 N 9/791 Mk. 9	<b>CABLE</b> , coded "3.B.AFS.KT-KT.★3.A.4," assembly						1	—	ECC	
	10-20 N 9/791 Mk. 20	<b>CABLE</b> , coded "4.A.AFS.KT-KT.AHS.1," assembly						1	—	ECC	
	10-20 N 9/791 Mk. 21	<b>CABLE</b> , coded "3.B.AFS.KT-KT.AHS.3," assembly						1	—	ECC	
	10-20 N 9/791 Mk. 22	<b>CABLE</b> , coded "5.B.AFS.KT-KT.AHS.2," assembly						1	—	ECC	
	10-20 N 9/791 Mk. 23	<b>CABLE</b> , coded "1.D.AFS.KT-KT.Q.CN.2," assy						1	—	ECC	
	10-20 N 9/791 Mk. 24	<b>CABLE</b> , coded "2.D.AFS.KT-KT.Q.CN.8," assy						1	—	ECC	
	10-20 N 9/791 Mk. 31	<b>CABLE</b> , coded "1.F.C.KT-KT.Q.M.8," assembly (Pre Mod. 1254)						1	—	ECC	
	10-20 N 9/791 Mk. 32	<b>CABLE</b> , coded "20.F.B.KT-KT.AFS.A.1," assembly						1	—	ECC	
	10-20 N 9/791 Mk. 33	<b>CABLE</b> , coded "1.F.J.KT-KT.AFS.A.5," assembly						1	—	ECC	
	10-20 N 9/791 Mk. 34	<b>CABLE</b> , coded "19.F.B.KT-KT.AFS.C.1," assembly						1	—	ECC	
	10-20 N 9/791 Mk. 35	<b>CABLE</b> , coded "1.F.C.KT-KT.QL.10," assembly (Mod. 1254)						1	—	ECC	
	10-20 N 9/891 Mk. 38	<b>CABLE</b> , coded "A.3.ALG.KT-KT.AFS.A.2," ... (Mod. 1428)						1	—	ECC	
	10-20 N 23359A	<b>CABLE</b> , coded "AFS.1-AFT.1-AAU.5," assembly						1	—	ECC	
	10-20 N 24921A	<b>CABLE</b> , coded "AFT.2-AFT.3-AFZ-AAU.5-AFS," assembly						1	—	ECC	
		Attachments for 10-20 N 24921A, Cable :— (At sealing plate)									
28S/9997545	A31/C16	Screw, 2 BA ... ..						8	—	C	
	10-20 N 22945A	<b>CABLE</b> , coded "B.6-AFS," assembly ...						1	—	ECC	
5K/—	SP.95/B6	<b>GROMMET</b> , auto-throttle indicator cables (Alternative DHS.1790/B6)						1	—	C	
	—	<b>INDICATOR</b> , artificial horizon, coded "M" (See sub-section FB)						—	—	—	
	10-20 CE 8137	<b>LABEL</b> , engraved "ON/OFF AUTO-THROTTLE MASTER SWITCH," at frame 96" (Port, 18 SWG)						1	L.72	LM	ECX2
		Attachments for 10-20 CE 8137, Label :—									
28D/1214368	AS.4598/1B	Bolt, 4 BA ... ..						1	—	C	

**INSTALLATION OF AUTO-THROTTLE, CODED "KT"**

Ref. No.	Part No.	Description	No. off	Material Specification	Class of Store or L.M	Plate No.
20306	10-20 N 24361A	<b>POTENTIOMETER</b> , trim, auto-throttle, c/w cables, coded "A-AAU," assembly (Mod. 1428)	1	—	C	
20307	10-20 N 24363A	<b>POTENTIOMETER</b> , trim, auto-throttle, c/w cables, coded "B-AAU," assembly (Mod. 1428)	1	—	C	
	10-20 N 24953A	<b>SWITCH</b> , auto-throttle disengage, c/w cables, assembly (Mod. 1588)	1	—	—	
	10-20 N 24953A/ CABLES	<b>CABLES</b> ... ..	QR	—	ECC	
21032	10-20 CE 8153A	<b>SWITCH</b> , auto-throttle disengage, assembly Spares for :—	1	—	C	ECX2
	BURGESS V4L1/631	<b>ACTUATOR</b> , auxiliary ... ..	2	—	—	ECX2
18982	10-20 CE 8065ND	<b>PIN</b> , pivot ... .. Attachments for 10-20 CE 8065ND, Pin :—	1	—	C	ECX2
28P/19565	SP.90/A2	Pin, split (SP.9/A3) ... ..	2	—	C	
28VV/9419401	SP.10/B	Washer ... ..	2	—	C	
5CW/—	BURGESS V4-T1	<b>SWITCH</b> , micro, coded "X" and "Y" Attachments for V4-T1, Switch (per pair) :—	2	—	—	ECX2
28M/9131100	A48/Z	Nut, 8 BA ... ..	2	—	C	
28S/9132406	A31/Z28	Screw, 8 BA ... ..	2	—	C	
		Attachments for 10-20 N 24953A, Switch :—				
28D/1200120	A25/14B	Bolt, 4 BA ... ..	2	—	C	
28M/10287	AGS.2001/B/1	Nut, 4 BA ... ..	2	—	C	
28VV/9419474	SP.15/B	Washer ... ..	2	—	C	
	10-20 N 24533A	<b>SWITCH</b> , trim, auto-throttle, c/w cables, coded "ALG-B," assembly (Mod. 1428)	1	—	—	
20300	10-20 N 24569	<b>BOX</b> , resistor, assembly ... ..	1	—	C	ECX2
	10-20 N 24533A/ CABLES	<b>CABLES</b> , link ... ..	QR	—	ECC	
20299	10-20 N 24567	<b>COVER</b> , switch ... .. Attachments for 10-20 N 24567, Cover :—	1	—	C	ECX2
28S/1200061	A33/A18	Screw, 6 BA ... ..	2	—	C	
	DHS.1681/B/2½	Tube, distance ... ..	2	—	—	ECX2
5K/—	SP.95/B8	<b>GROMMET</b> (Alternative DHS.1790/B8) ...	1	—	C	
5K/—	SP.95/B12	<b>GROMMET</b> (Alternative DHS.1790/B12) ...	1	—	C	
5355-99-097-0179	—	<b>KNOB</b> , finger ... ..	1	—	C	
20298	10-20 N 24481A	<b>PLATE</b> , mounting, switch, assembly ...	1	—	C	ECX2
		Attachments for 10-20 N 24481A, Plate :—				
28S/1214115	AS.2993/4B	Screw, 4 BA ... ..	2	—	C	
20301	10-20 N 24513A	<b>PLATE</b> , top, assembly ... ..	1	—	C	ECX2
20302	10-20 N 24515	<b>GASKET</b> ... ..	1	—	C	ECX2
20296	10-20 N 24405A	<b>RESISTOR</b> , wired, assembly ... ..	1	—	C	ECX2
		Attachments for 10-20 N 24405A, Resistor :—				
28M/9131100	A48/Z	Nut, 8 BA ... ..	2	—	C	
28S/9132086	A31/Z12	Screw, 8 BA ... ..	2	—	C	
20303	10-20 N 24583ND	Spacer ... ..	2	—	C	ECX2
28VV/9141863	SP.27/Z	Washer ... ..	2	—	C	

ELECTRICAL INSTALLATIONS

INSTALLATION OF AUTO-THROTTLE, CODED "KT"

Ref. No.	Part No.	Description	No. off	Material Specification	Class of Store or L.M	Plate No.
20304	WARD BROOKE WB.2365/1/5/B	<b>SLEEVE</b> ... ..	QR	—	C	ECX2
	10-20 N 24535A	<b>SWITCH</b> , assembly ... .. Attachments for 10-20 N 24533A, Switch :—	1	—	C	ECX2
28D/1218385	AS.1248/2B	Bolt, 4 BA (Fit at resistor assembly) ... ..	2	—	C	
28S/1214154	AS.2992/5B	Screw, 4 BA (Fit at switch assembly) ... ..	2	—	C	
5930-99-051-0578	10-20 N 22959A	<b>SWITCH</b> , master, auto-throttle, c/w cables, coded "E-J," assembly	1	—	—	
	10-20 N 22959A/ CABLES	<b>CABLE</b> , assembly ... ..	1	—	ECC	
	—	<b>SWITCH</b> , single pole ... ..	1	—	P	
	10-20 N 23703A	<b>SWITCH</b> , micro, undercarriage selector, outboard, c/w cables, coded "S," assembly	1	—	—	
	10-20 N 23703A/ CABLES	<b>CABLE</b> , assembly ... .. (For cables circuit coded "KT")	1	—	ECC	
28D/1011025	A25/24C	<b>SWITCH</b> , micro, coded "S" (See sub-section EAE)	—	—	—	
	—	Attachments for 10-20 N 23703A, Switch :— Bolt, 2 BA ... ..	3	—	C	
10H/23864	—	<b>INSTALLATION AT REAR PRESSURE BULK-HEAD, CODED "Q"</b> (Drg. Nos. 10-20 N 10635 and 10-20 N 14755A)	1	—	—	
	—	<b>BLOCK</b> , fuse, coded "CN," group ... ..	1	—	—	
	—	<b>BLOCK</b> , fuse, 6-way (See sub-section EBV) ... ..	—	—	—	
	—	<b>FUSE</b> , 5 amp. ... ..	2	—	C	
10H/23862	—	<b>BLOCK</b> , fuse, coded "M," group (Pre Mod. 1254)	1	—	—	
	—	<b>BLOCK</b> , fuse, 12-way (See sub-section EBV)	—	—	—	
10H/23862	—	<b>FUSE</b> , 10 amp. ... ..	1	—	C	
	—	<b>BLOCK</b> , fuse, coded "L," group (Mod. 1254)	1	—	—	
26DV/7529	DHS.438/C	<b>BLOCK</b> , fuse ... ..	—	—	—	
	26DV/4969	<b>FUSE</b> , 10 amp. ... ..	1	—	C	
28M/10288	AGS.2001/C/1	<b>TERMINAL</b> , earth, stn. 3, coded "A," group ... ..	1	—	—	
	28W/9419475	<b>TAG</b> , corrosion ... ..	1	—	C	BA13
28M/10288	AGS.2001/C/1	<b>TERMINAL</b> , earth, assembly ... .. (For breakdown see DHS. Data Sheet)	1	—	C	
	28W/9419475	Attachments for DHS.437/C, Terminal :— Nut, 2 BA ... ..	2	—	C	
28M/10288	AGS.2001/C/1	Washer ... ..	2	—	C	
	28W/9419475	<b>INSTALLATION AT PORT WING DECK PANEL, CODED "FA"</b> (Drg. Nos. 10-20 N 11143 and 10-20 N 11593)	1	—	—	
5X/9149641	10-20 N 9/791 Mk. 14 AIRCRAFT MARINE PRODUCTS 320559	<b>CABLE</b> , coded "AGA.KT-KT.AFW.1," assembly	1	—	ECC	
	—	<b>CONNECTOR</b> , in-line, coded "AGA" ... ..	1	—	—	
5X/9149641	—	<b>INSTALLATION IN PORT ENGINE BAY</b> (Drg. Nos. 10-20 N 5123 and 10-20 N 11593)	1	—	—	
	—	<b>ACTUATOR</b> , throttle, coded "AFV" (See sub-section CG)	—	—	—	
5X/9149641	DHS.456/5	<b>BLOCK</b> , terminal, "AFW," group ... ..	1	—	—	
	—	<b>BLOCK</b> , terminal, 5-way, assembly ... .. (For breakdown see DHS. Data Sheet)	1	—	—	
5X/9149641	PLESSEY CZ.26805	<b>COVER</b> , terminal block (5940-99-914-9641)	1	—	C	BA13
	10-20 N 23119	<b>GUARD</b> , terminal block, 20 SWG ... ..	2	L.72	LM	ECX2
28M/10327	AGS.2002/B/1	<b>NUT</b> , 4 BA ... ..	2	—	C	
5X/9450403	PLESSEY Z.28426	<b>PILLAR</b> , fixing, 4 BA (5340-99-945-0403) ... ..	1	—	C	EBG1

**ELECTRICAL INSTALLATIONS**  
**INSTALLATION OF AUTO-THROTTLE, CODED "KT"**

Ref. No.	Part No.	Description						No. off	Material Specification	Class of Score or L.M	Plate No.
		1	2	3	4	5	6				
28E/9000883	10-20 N 9/791 Mk. 15	<b>CABLE</b> , coded "5.B.★9.KT-KT.AFW.2," assembly						1	—	ECC	
	10-20 N 22295A	<b>CABLE</b> , coded "AFU-AFZ." assembly ... ..						1	—	ECC	
	AS.3180/9B	<b>CLIP</b> , "P." attaching actuator cables to gear box beam, Port						1	—	C	
		Attachments for AS.3180/9B, Clip :—									
28D/1008149	A25/2B	Bolt, 4 BA ... ..						1	—	C	
28M/10287	AGS.2001/B/1	Nut, 4 BA ... ..						1	—	C	
28W/9419465	SP.13/B	Washer ... ..						1	—	C	
28E/1201809	AS.3180/6B	<b>CLIP</b> , "P." attaching cables coded "AFU-AFZ.1" to gear box beam, Port						2	—	C	
		Attachments for AS.3180/6B, Clip :—									
28D/1010658	A25/1B	Bolt, 4 BA ... ..						1	—	C	
28E/9436947	AS.3180/4B	<b>CLIP</b> , "P." attaching magnetic clutch cables to gear box beam, Port						2	—	C	
		Attachments for AS.3180/4B, Clip :—									
28D/1010658	A25/1B	Bolt, 4 BA ... ..						1	—	C	
28M/10287	AGS.2001/B/1	Nut, 4 BA ... ..						1	—	C	
28W/9419465	SP.13/B	Washer ... ..						1	—	C	
		<b>CLUTCH</b> , magnetic, coded "AFX" (See sub-section CG)						—	—	—	
5935-99-944-4086	PLESSEY UK-AN(ET)9204-20-27P	<b>PLUG</b> , free, attach to "AFZ" end of cable coded "AFU-AFZ1"						1	—	C	
5935-99-971-7833	PLESSEY 508/2/04367	<b>PLUG</b> , filler ... ..						2	—	C	
26DV/4969	DHS.437/C	<b>TERMINAL</b> , earth, strn. 9, coded "A." assembly (For breakdown see DHS. Data Sheet)						1	—	C	
		Attachments for DHS.437/C, Terminal :—									
28M/10288	AGS.2001/C/1	Nut, 2 BA ... ..						2	—	C	
28S/15552	A32/C18	Screw, 2 BA ... ..						2	—	C	
28W/9419402	SP.13/C	Washer ... ..						2	—	C	
5310-99-914-5767	PLESSEY 2Z.139599	<b>WASHER</b> , packing, panel, at socket "AFU" ...						1	—	C	
32B/—	—	<b>TAPE</b> , identification, numbers and letters, use from Ref. Nos. 32B/1087 to 32B/1120 inclusive, as required						QR	—	C	

ELECTRICAL INSTALLATIONS

INSTALLATION OF AUTO-THROTTLE, CODED "KT"

Ref. No.	Part No.	Description						No. off	Material Specification	Class of Store or L.M.	Plate No.
		1	2	3	4	5	6				

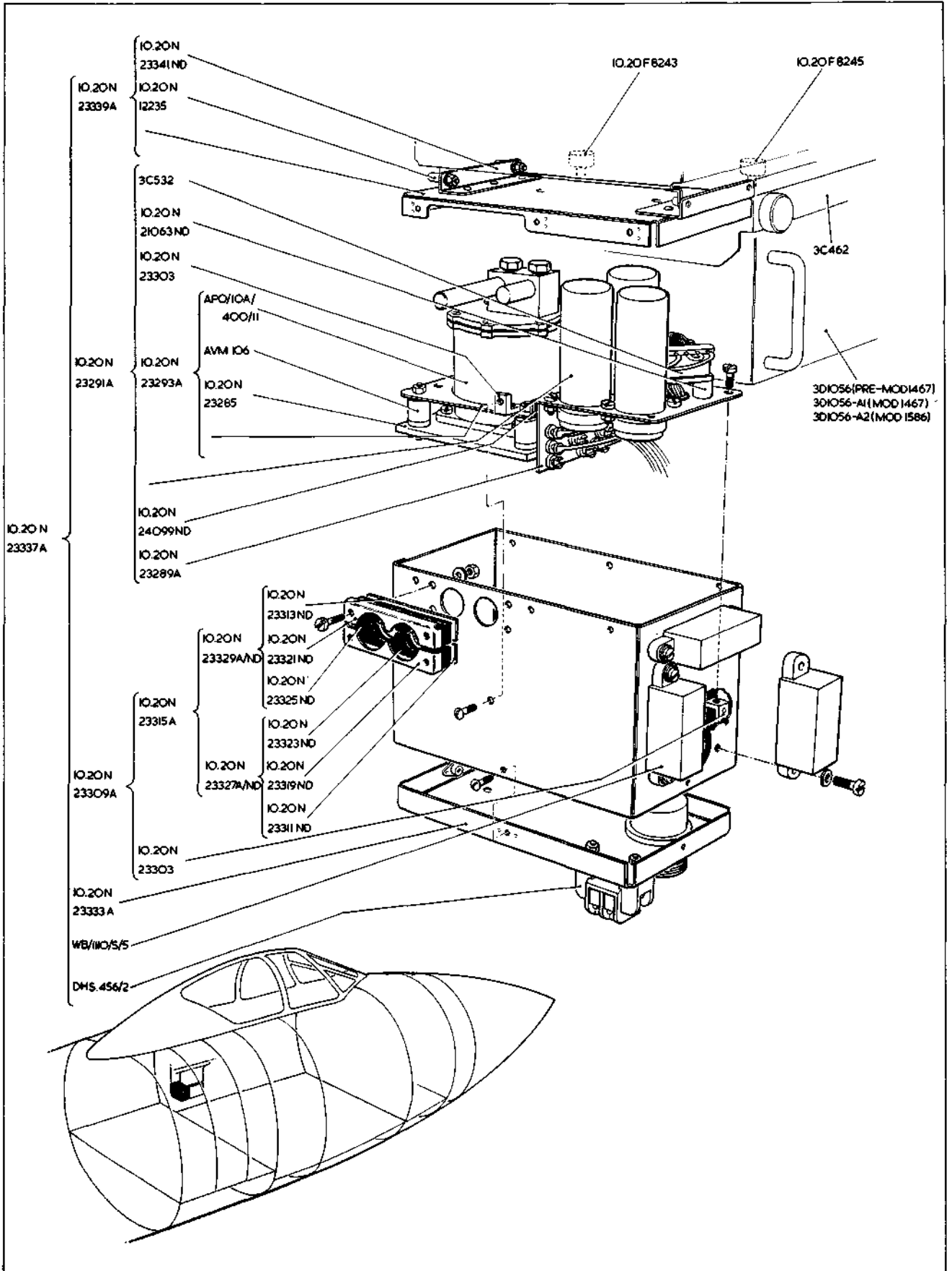

ECX. I

ELECTRICAL INSTALLATION

ECX. I

AUTO - THROTTLE CODED KT.

[A.L. 73]

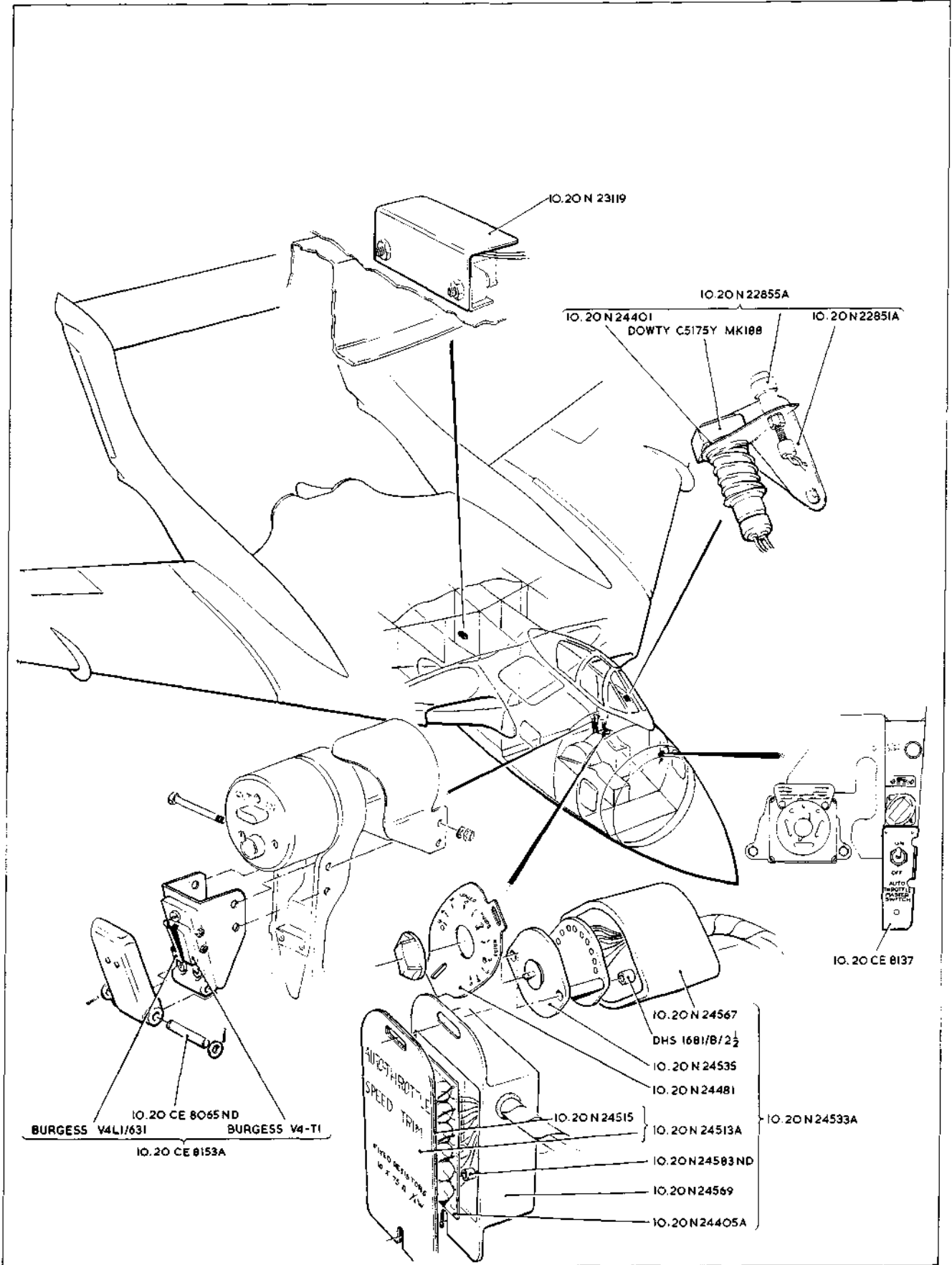

ECX.2

ELECTRICAL INSTALLATION

ECX.2

AUTO-THROTTLE CODED KT

[A.L.73]

This file was downloaded  
from the RTFM Library.

Link: [www.scottbouch.com/rtfm](http://www.scottbouch.com/rtfm)

Please see site for usage terms,  
and more aircraft documents.

