

**EQUIPMENT SPECIAL OPERATIONAL
BULL PUP WEAPON SYSTEM
(SPECIAL ORDER ONLY)**

Ref. No.	Part No.	Description	No. off	Material Specification	Class of Store or L.M.	Plate No.
	—	G.A. BULL PUP WEAPON SYSTEM (Drg. No. 10-20 A 5999) (Mod. 5095) (SPECIAL ORDER ONLY)	1	—	—	
	—	CONVERTER, SIGNAL DATA IN CONTROL POD INSTALLATION (Drg. No. 10-20 N 22869) (Mod. 5113) (SPECIAL ORDER ONLY) (Required only when Selector control is fitted—See Page JL7) Spares for :—	1	—	—	
	CV.890.ARW73	CONVERTER , signal data (Service supply and fit) Attachments for CV.890.ARW73, Converter :—	1	—	—	JL1
28D/1011238	A25/3E 10-20 A 5571	Bolt, 1/2" BSF Bush	4 4	— —	C —	JL1
	—	DISTRIBUTOR , bomb (See sub-section JK) ...	—	—	—	
	—	GRIP, CONTROL, BULL PUP, ON PILOT'S L.H. CONSOLE, INSTALLATION (Drg. No. 10-20 N 22873) (Mod. 5112) (SPECIAL ORDER ONLY) (Alternative to Selector control—See Page JL7) Spares for :—	1	—	—	
	10-20 N 22871A	GRIP , control, assembly	1	—	—	JL1
19044	10-20 N 22831A	BRACKET , mounting	1	—	C	JL1
27J/744	DUNLOP AC.61538	GRIP , control Attachments for AC.61538, Grip :—	1	—	P	JL1
28D/1200119	A25/4C	Bolt, 2 BA	4	—	C	
28M/10288	AGS.2001/C/1	Nuc, 2 BA	4	—	C	
28W/9419402	SP.13/C	Washer	4	—	C	
	10-20 A 3219A	LAUNCHER, BULL PUP, ASSEMBLY (Mod. 5109) (SPECIAL ORDER ONLY)	1	—	—	JL1
	10-20 A 3215A	CHANNEL , fastener, L.H., aft, assembly ...	1	—	—	JL1
	10-20 A 3216A	CHANNEL , fastener, R.H., aft, assembly ...	1	—	—	JL1
	—	Spares for :—				
28FP/—	DZUS RFC/5	RECEPTACLE , fastener	1	—	—	
28FP/—	DZUS RF5/5	SPACER , fastener	2	—	—	
	10-20 A 3207A	CHANNEL , fastener, L.H. forward, assembly ...	1	—	—	JL1
	10-20 A 3208A	CHANNEL , fastener, R.H. forward, assembly ...	1	—	—	JL1
	—	Spares for :—				
19039	10-20 A 3213	BLOCK , door stay hinge	2	—	C	JL1
28FP/—	DZUS RFC/5	RECEPTACLE , fastener	5	—	—	
28FP/—	DZUS RF5/5	SPACER , fastener	10	—	—	
	—	LAUNCHER (Service supply and fit)	1	—	—	
	10-20 A 5593A	POD, CONTROL, BULL PUP, C/W ELECTRICAL COMPONENTS, ASSEMBLY (Mod. 5096) (SPECIAL ORDER ONLY)	1	—	—	JL2
	—	ELECTRICAL COMPONENTS (See sub-section EDC)	—	—	—	

**EQUIPMENT SPECIAL OPERATIONAL
BULL PUP WEAPON SYSTEM
(SPECIAL ORDER ONLY)**

Ref. No.	Part No.	Description	No. off						Material Specification	Class of Store or L.M	Place No.
			1	2	3	4	5	6			
	10-20 A 5809A/ND	POD, control, assembly (Pre Mod. 5164) ...						1	—	—	JL2
	10-20 A 6233A/ND	POD, control, assembly (Mod. 5164) ...						1	—	—	JL2
	10-20 A 5643A	CENTRE-SECTION STRUCTURE, assembly						1	—	—	JL2
		Spares for :—									
19138	10-20 A 5429	BOLT , eye, pivot for struts ...						2	—	C	JL2
		Attachments for 10-20 A 5429, Bolt :—									
28M/13935	A58/ES	Nut, 3/4" BSF ...						1	—	C	
28P/1011031	SP.9/C10	Pin, split ...						1	—	C	
26FN/3275	DHS.69/DD	Shim ...						1	—	C	JL2
	10-20 A 5671ND	Washer, saddle, 10 SWG ...						1	L.72	LM	JL2
28W/9128188	SP.55/E	Washer, spring, double ...						1	—	C	
19125	10-20 A 5293	BRACKET , hinge, front ...						1	—	C	JL2
		Attachments for 10-20 A 5293, Bracket :—									
28D/1013178	AS.1242/5E	Bolt, 2 BA ...						2	—	C	
28M/1011475	A27/EP	Nut, 2 BA ...						2	—	C	
28W/9419405	SP15/E	Washer ...						2	—	C	
19126	10-20 A 5375	BRACKET , hinge, rear ...						1	—	C	JL2
		Attachments for 10-20 A 5375, Bracket :—									
28D/1007976	AS.1242/4C	Bolt, 2 BA ...						2	—	C	
28M/9403520	A27/CP	Nut, 2 BA ...						2	—	C	
	10-20 A 5665ND	Washer, saddle, 10 SWG ...						1	L.72	LM	JL2
28W/9419475	SP.15/C	Washer ...						2	—	C	
	10-20 A 3327	BRACKET , lower, rear cone strut (For spares use 10-20 A 6117ND)						1	—	—	JL2
19253	10-20 A 6117ND	BRACKET , lower, rear cone strut (Spares condition)						1	—	C	
	10-20 A 3329	BRACKET , rear cone strut, 18 SWG ...						1	L.72	LM	JL2
	10-20 A 5513A	BRACKET , time delay unit, assembly ...						1	—	—	JL2
	10-20 A 5515ND	BRACKET , bare, 22 SWG ...						1	L.72	LM	JL2
28M/9434253	AGS.2007/B/1	NUT , anchor, 4 BA ...						3	—	C	
	10-20 A 5517A	BRACKET , terminal blocks, assembly ...						1	—	—	JL2
	10-20 A 5519ND	BRACKET , bare, 22 SWG ...						1	L.72	LM	JL2
28M/9434253	AGS.2007/B/1	NUT , anchor, 4 BA ...						4	—	C	
	10-20 A 5577	CHANNEL , nose strut stowage, 18 SWG ...						1	L.72	LM	JL2
	10-20 A 5583	CHANNEL , tail cone strut stowage, 18 SWG						1	L.72	LM	JL2
	10-20 A 3321	CLEAT , aft, 18 SWG ...						2	L.72	LM	JL2
	10-20 A 5400	CLEAT , forward, transmitter beam, 20 SWG ...						1	L.72	LM	JL2
	10-20 A 5399	CLEAT , forward, transmitter beam, 20 SWG ...						1	L.72	LM	JL2
	10-20 A 3325	CLEAT , frame, 20 SWG ...						4	L.72	LM	JL2
	10-20 A 5669ND	CLEAT , frame, 20 SWG ...						4	L.72	LM	JL2
	10-20 A 5401	CLEAT , rear, transmitter beam, 20 SWG ...						1	L.72	LM	JL2
	10-20 A 5402	CLEAT , rear, transmitter beam, 20 SWG ...						1	L.72	LM	JL2
19146	10-20 A 5573	CLIP , nose strut stowage, assembly ...						1	—	C	JL2
19147	10-20 A 5579	CLIP , tail cone strut stowage, assembly ...						1	—	C	JL2
	10-20 A 3293A	COVER , fastener, rear (For spares use 10-20 A 6113ND)						2	—	—	JL2
19250	10-20 A 6113ND	COVER , fastener, rear (Spares condition)						2	—	C	
19129	10-20 A 5469	COVER , fastener, forward ...						2	—	C	JL2
	KING AIRCRAFT C.14393	FASTENER ...						4	—	C	JL2
		Attachments for C.14393, Fastener (at latch :—									
28D/9140645	A25/10C	Bolt, 2 BA ...						2	—	C	
28M/10288	AGS.2001/C/1	Nut, 2 BA ...						2	—	C	
28W/9419404	SP.16/C	Washer ...						2	—	C	

**EQUIPMENT SPECIAL OPERATIONAL
BULL PUP WEAPON SYSTEM
(SPECIAL ORDER ONLY)**

Ref. No.	Part No.	Description						No. off	Material Specification	Class of Store or L.M.	Plate No.
		1	2	3	4	5	6				
	10-20 A 3324							1	—	—	JL2
19252	10-20 A 6116ND							1	—	C	
	10-20 A 3323							1	—	—	JL2
19251	10-20 A 6115ND							1	—	C	
	10-20 A 5539							1	—	—	JL2
19249	10-20 A 6111ND							1	—	C	
19124	10-20 A 3285							1	—	C	JL2
	10-20 A 5637							2	—	—	JL2
	10-20 A 5638							2	—	—	JL2
5K/9140980	SP.40/A16							2	—	C	
19137	10-20 A 5427							4	—	C	JL2
28M/10290	AGS.2001/E/1							1	—	C	
26FN/3263	DHS.69/EE							1	—	C	
19122	10-20 A 5305							2	—	C	JL2
28M/10332	AGS.2002/J/1							1	—	C	
28W/9419477	SP.15/J							1	—	C	
28D/14217	A30/6G							1	—	—	
28M/14537	A58/GS							4	—	C	
28P/9527619	SP.90/C7							4	—	C	
28W/9419403	SP.13/G							4	—	C	
95400	10-20 Y 8863A							1	—	C	JL2
19043	10-20 N 22329							1	—	C	JL2
	10-20 A 5653ND							1	L.72	LM	JL2
	—							1	—	—	
	10-20 A 5509ND							1	—	LM	JL2
	10-20 A 5511ND							1	—	LM	JL2
19141	10-20 A 5501ND							1	—	C	JL2
19142	10-20 A 5503ND							1	—	C	JL2
28D/1007979	AS.1246/1B							10	—	C	
28M/10327	AGS.2002/B/1							10	—	C	
28W/9419474	SP.15/B							10	—	C	
19143	10-20 A 5505ND							1	—	C	JL2
19145	10-20 A 5506ND							1	—	C	JL2
28D/1007979	AS.1246/1B							9	—	C	
28M/10327	AGS.2002/B/1							9	—	C	
28W/9419474	SP.15/B							9	—	C	

**EQUIPMENT SPECIAL OPERATIONAL
BULL PUP WEAPON SYSTEM
(SPECIAL ORDER ONLY)**

Ref. No.	Part No.	Description	1 2 3 4 5 6						No. off	Material Specification	Class of Store or LM	Plate No.
			19144	10-20 A 5507ND	STRIP , seal retaining, rear, R.H. ...							
		Attachments for 10-20 A 5507ND, Strip :—										
28D/1007979	AS.1246/1B	Bolt, 4 BA ...						4	—	C		
28M/10327	AGS.2002/B/1	Nut, 4 BA ...						4	—	C		
28W/9419474	SP.15/B	Washer ...						4	—	C		
	10-20 A 3331ND	SHIM , 1/8" thick, Attewell ...						4	LA.3	LM	JL2	
19148	10-20 A 5641	SLEEVE , suspension ...						1	—	C	JL2	
		Attachments for 10-20 A 5641, Sleeve :—										
28D/9133013	A25/5C	Bolt, 2 BA ...						2	—	C		
28W/9419402	SP.13/C	Washer ...						2	—	C		
19128	10-20 A 5488	STIFFENER , front ...						2	—	C	JL2	
19127	10-20 A 5487	STIFFENER , front ...						2	—	C	JL2	
	10-20 A 5539	STIFFENER , rear hinge (For spares use 10-20 A 6121ND)						1	—	—	JL2	
19255	10-20 A 6121ND	STIFFENER , rear hinge (Spares condition)						1	—	C		
	10-20 A 5540	STIFFENER , rear hinge (For spares use 10-20 A 6122ND)						1	—	—	JL2	
19256	10-20 A 6122ND	STIFFENER , rear hinge (Spares condition)						1	—	C		
19139	10-20 A 5443A	STRUT , nose, assembly ...						1	—	C	JL2	
19140	10-20 A 5457A	STRUT , tailcone, assembly ...						1	—	C	JL2	
		Attachments for 10-20 A 5443A or 10-20 A 5457A, Strut :—										
28P/831	SP.4Y/B5	Pin, shackle ...						1	—	C		
28P/9527619	SP.90/C7	Pin, split (SP.9/C8) ...						1	—	C		
28W/9419475	SP.15/C	Washer ...						1	—	C		
19149	10-20 A 5311A	CONE , rear fairing, assembly (Pre Mod. 5160)						1	—	C	JL3	
19780	10-20 A 6227A	CONE , rear fairing, assembly (Mod. 5160) ...						1	—	C	JL3	
		Spares for :—										
	10-20 A 5545	CLEAT , 20 SWG ...						2	L.72	LM	JL3	
19153	10-20 A 5329	CONE , end (Pre Mod. 5160) ...						1	—	C	JL3	
19781	10-20 A 6171	CONE , end (Mod. 5160) ...						1	—	C	JL3	
19155	10-20 A 5333	COVER , latch ...						2	—	C	JL3	
19152	10-20 A 5327	FRAME , rear ...						1	—	C	JL3	
	10-20 A 5331A	HINGE , assembly (For spares use 10-20 A 6119A/ND)						1	—	—	JL3	
19254	10-20 A 6119A/ND	HINGE , assembly (Spares condition) ...						1	—	C		
	10-20 A 5319ND	PACKING , hinge, 18 SWG ...						1	L.72	LM	JL3	
	10-20 A 5395ND	PLATE , shim, 1/8" thick, Attewell ...						2	LA.3	LM	JL3	
	10-20 A 5335ND	PLATE , spigot, 10 SWG ...						2	L.72	LM	JL3	
19150	10-20 A 5313ND	SKIN , L.H. ...						1	—	C	JL3	
19159	10-20 A 5315ND	SKIN , R.H. ...						1	—	C	JL3	
	10-20 A 5413	STRIP , packing, 12 SWG ...						1	L.72	LM	JL3	
19120	10-20 A 5269A	NOSE , assembly (Pre Mod. 5160) ...						1	—	P	JL3	
19782	10-20 A 6229A	NOSE , assembly (Mod. 5160) ...						1	—	P	JL3	
		Spares for :—										
	10-20 A 5275A	BRACKET , hinge, assembly (For spares use 10-20 A 6109ND)						1	—	—	JL3	
19248	10-20 A 6109ND	BRACKET , hinge, assembly (Spares condition)						1	—	C		
	10-20 A 5383ND	PLATE , bearing, 10 SWG ...						2	S.514	LM	JL3	
	10-20 A 5349ND	SHIM , 1/8" thick, Attewell ...						2	LA.3	LM	JL3	

**EQUIPMENT, SPECIAL OPERATIONAL
BULL PUP WEAPON SYSTEM
(SPECIAL ORDER ONLY)**

Ref. No.	Part No.	Description	No. off	Material Specification	Class of Store or L.M	Plate No.
	—	PYLONS, BULL PUP, INSTALLATION ...	1	—	—	
		(Drg. No. 10-20 A 5235)				
19037	10-20 A 5243	BLOCK , fairing, aft, L.H. ...	1	—	C	JL4
19038	10-20 A 5244	BLOCK , fairing, aft, R.H. ...	1	—	C	JL4
		Attachments for 10-20 A 5243 or 10-20 A 5244, Block :—				
28D/9133011	A25/2C	Bolt, 2 BA ...	13	—	C	
4927	DHS.772/C/2	Washer, under bolt head ...	7	—	C	JL4
15583	DHS.775/C/2	Washer, under bolt head ...	6	—	C	JL4
19035	10-20 A 5241	BLOCK , fairing, forward, L.H. ...	1	—	C	JL4
19036	10-20 A 5242	BLOCK , fairing, forward, R.H. ...	1	—	C	JL4
		Attachments for 10-20 A 5241 or 10-20 A 5242, Block :—				
28D/1200119	A25/4C	Bolt, 2 BA ...	3	—	C	
15583	DHS.775/C/2	Washer, under bolt head ...	3	—	C	
	10-20 A 5249A	PAD , bearing, aft, assembly ...	1	—	—	JL4
		Attachments for 10-20 A 5249A, Pad :—				
28D/1007976	AS.1242/4C	Bolt, 2 BA ...	2	—	C	
	10-20 A 5131A	PYLON , complete with electrical components, Port, assembly	1	—	—	JL4
	10-20 A 5132A	PYLON , complete with electrical components, Starboard, assembly	1	—	—	JL4
		Spares for :—				
19031	10-20 A 5245	BOLT , securing launcher, group ...	1	—	—	
19032	10-20 A 5247	BOLT ...	2	—	C	JL4
		NUT ...	2	—	C	JL4
28P/9429652	SP.9/E10	PIN , split ...	2	—	C	
19025	10-20 A 3221A	DOOR , fairing, L.H., assembly ...	1	—	C	JL4
		Spares for :—				
19026	10-20 A 3277	BRACKET , stay ...	2	—	C	JL4
	DZUS					
28FP/—	EFR5/49B/DS	FASTENER ...	2	—	—	
	DZUS					
28FP/—	EFR5/44B/DS	FASTENER ...	6	—	—	
	10-20 A 5905ND	PACKING , landing strip, 10 SWG ...	1	L.72	LM	JL4
28FP/—	DZUS RFC/5	RECEPTACLE , fastener ...	2	—	—	
28FP/—	DZUS RF5/5	SPACER , fastener ...	4	—	—	
	10-20 A 3231ND	STRIP , landing, 14 SWG ...	1	L.72	LM	JL4
19027	10-20 A 3223A	DOOR , fairing, R.H., assembly ...	1	—	C	JL4
		Spares for :—				
19026	10-20 A 3277	BRACKET , stay ...	2	—	C	JL4
19028	10-20 A 3229ND	CAP , nose ...	1	—	C	JL4
	DZUS					
28FP/—	EFR5/44B/DS	FASTENER ...	6	—	—	
	DZUS					
28FP/—	EFR5/60B/DS	FASTENER ...	2	—	—	

**EQUIPMENT, SPECIAL OPERATIONAL
BULL PUP WEAPON SYSTEM
(SPECIAL ORDER ONLY)**

Ref. No.	Part No.	Description	No. off	Material Specification	Class of Store or L.M	Plate No.
12715	10-20 PT 553	GROMMET	1	—	C	JL4
19020	10-20 A 5171A	HINGE , at leading edge fairing, assembly Attachments for 10-20 A 5171A, Hinge :—	2	—	C	JL4
28D/1007974	AS.1242/1C	Bolt, 2 BA	2	—	C	
28D/8303	AS.1242/3C	Bolt, 2 BA	2	—	C	
28M/10288	AGS.2001/C/1	Nut, 2 BA	4	—	C	
28W/9419454	SP.10/C	Washer	4	—	C	
19020	10-20 A 5171A	HINGE , rear and intermediate, assembly Attachments for 10-20 A 5171A, Hinge :—	4	—	C	JL4
28D/1007974	AS.1242/1C	Bolt, 2 BA	4	—	C	
	10-20 A 5139	Plate, 14 SWG	1	L.72	LM	
15907	10-20 A 3075	NUT , pylon retaining	1	—	C	JL4
12349	10-20 A 1723	NUT , sleeve	1	—	C	JL4
19022	10-20 A 1531	PAD , bearing, front spigot	1	—	C	JL4
12364	10-20 A 1689	PIN , locking, nut and sleeve	2	—	C	JL4
	10-20 A 5085A	PYLON (casting)	1	—	—	JL4
		Spares for :—				
	10-20 A 5095	BUSH	4	—	—	JL4
	ARMSTRONG					
	2631/2CN/277	INSERT , Heli-coil, screw lock thread, at hinge positions	16	—	—	JL4
	10-20 A 5561ND	TUBE , distance, 3/4" o/d x 18 SWG x 4" 30 long	2	T.26	LM	JL4
12344	10-20 A 1725	SLEEVE , inner, top	1	—	C	JL4
19023	10-20 A 5169	SPIGOT , rear	1	—	C	JL4
	—	STAY , doors, group	2	—	—	
19034	10-20 A 3267	LINK , lower	1	—	C	JL4
19033	10-20 A 3265	LINK , upper	1	—	C	JL4
28P/834	SP.4Y/B8	PIN , shackle, centre	1	—	C	
28P/832	SP.4Y/B6	PIN , shackle, lower	1	—	C	
28P/830	SP.4Y/B4	PIN , shackle, upper	1	—	C	
28P/1007741	SP.9/C8	PIN , split	3	—	C	
28W/9419402	SP.13/C	WASHER	3	—	C	
13587	DHS.772/C/1	WASHER	3	—	C	JL4
	—	SELECTOR, CONTROL, BULL PUP ON PILOT'S L.H. CONSOLE, INSTALLATION (Drg. No. 10-20 N 22827, Mod. 5113) (SPECIAL ORDER ONLY) (Alternative to Grip, control see Page JL1) Spares for :—	1	—	—	
	10-22 N 751A	CABLE , coded " MT3-AFG1," assembly	1	—	ECC	
	10-20 N 22817A	COLUMN , mounting, assembly	1	—	—	JL1
	C-3105-ARW-73	SELECTOR (Service supply and fit)	1	—	—	JL1
		Attachments for C-3105-ARW-73, Selector :—				
28D/18753	AS.4597/7C	Bolt, 2 BA	4	—	C	
28M/10288	AGS.2001/C/1	Nut, 2 BA	4	—	C	
28W/9419454	SP.10/C	Washer	4	—	C	

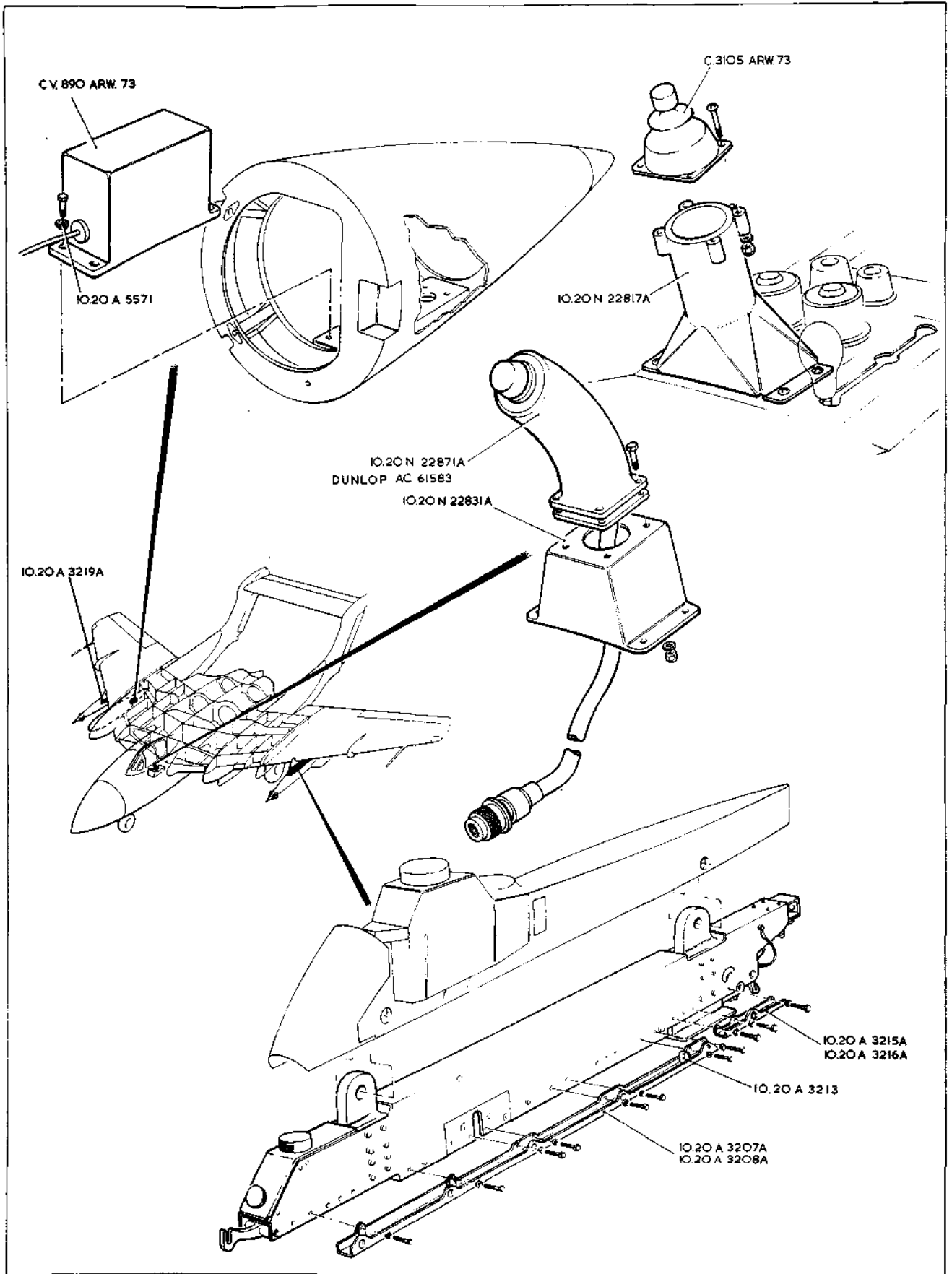

JL.1 EQUIPMENT, SPECIAL OPERATIONAL
BULL PUP WEAPON SYSTEM

JL.1
 [AL 60]

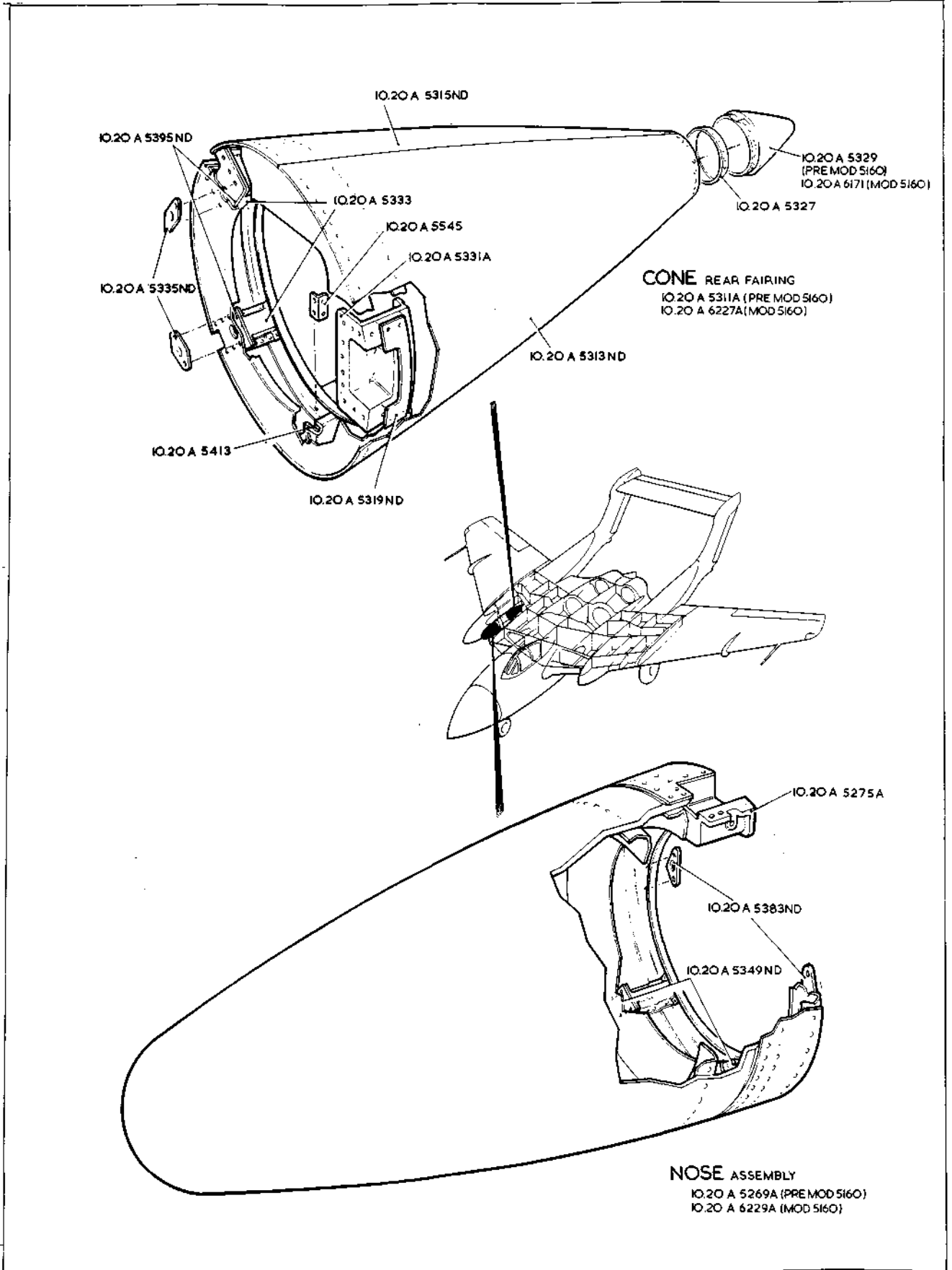

JL.3

**EQUIPMENT, SPECIAL OPERATIONAL
BULL PUP WEAPON SYSTEM**

JL.3
[A.L. 66]

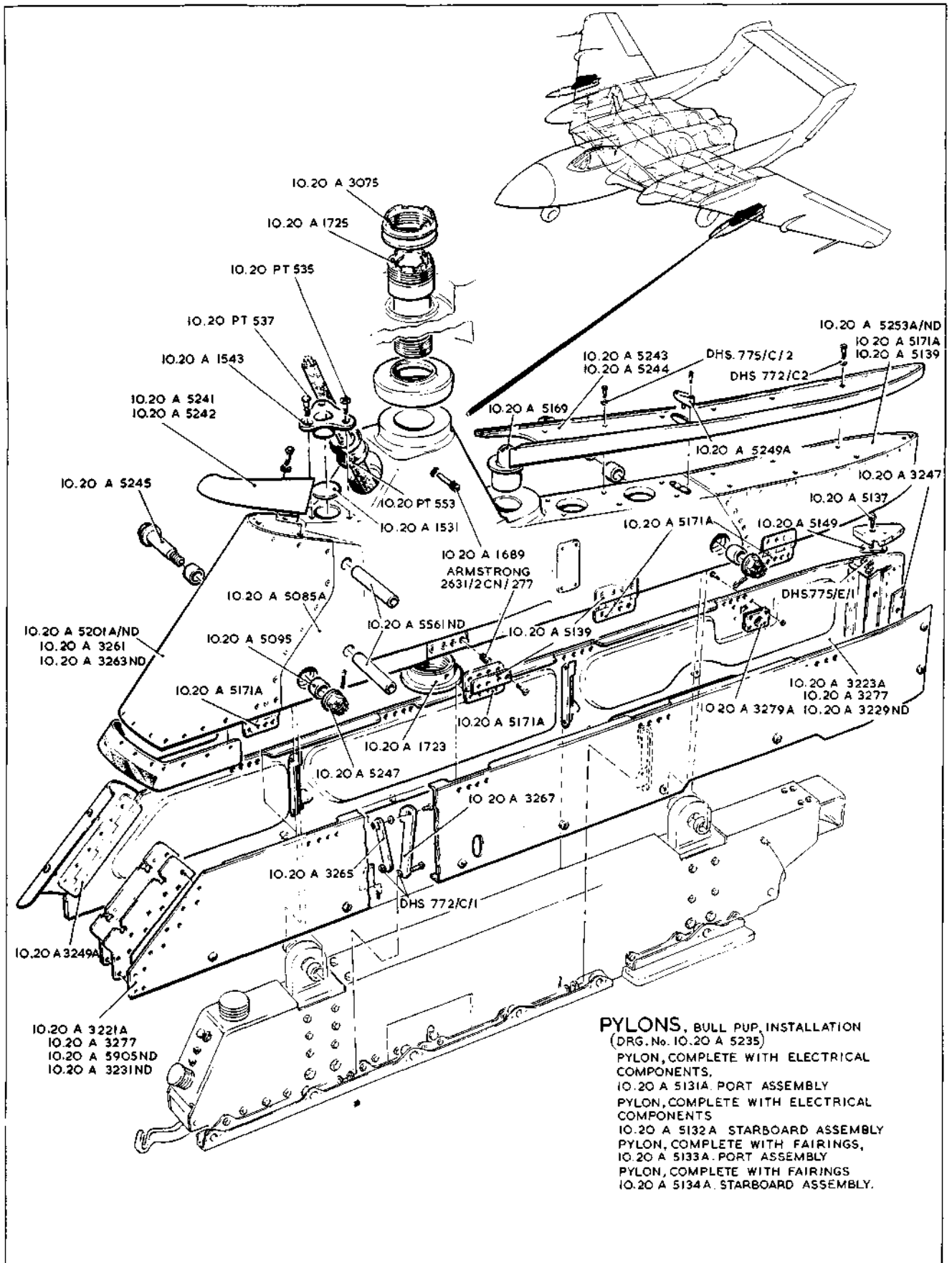

JL.4

EQUIPMENT, SPECIAL OPERATIONAL

JL.4

BULL PUP WEAPON SYSTEM

AL 60

This file was downloaded
from the RTFM Library.

Link: www.scottbouch.com/rtfm

Please see site for usage terms,
and more aircraft documents.

