

**EQUIPMENT, SPECIAL OPERATIONAL
PHOTOGRAPHIC RECONNAISSANCE
(SPECIAL ORDER ONLY)**

Ref. No.	Part No.	Description	No. off	Material Specification	Class of Store or L.M	Place No.
		G.A. OF PHOTOGRAPHIC RECONNAISSANCE (Drg. No. 10-20 M 1159) (Mod. 5126) (SPECIAL ORDER ONLY)	1	—	—	
	10-20 M 1293A	POD , outboard light stores pylon, assembly, Starboard	1	—	—	JM2
19051	10-20 M 1107A	Spares for :— ADAPTER , elbow, assembly	1	—	C	JM2
28S/9435715	A33/B16	Attachments for 10-20 M 1107A, Adapter :— Screw, 4 BA	3	—	C	
	—	CAMERA INSTALLATION (Drg. No. 10-20 M 1297A)	1	—	—	
	10-20 M 1175A/ND	CAMERA , oblique, assembly	1	—	—	JM2
	10-20 M 1017A	Spares for :— BRACKET , mounting, assembly	1	—	—	JM 2
20407	10-20 M 1521A	Spares for :— FASTENER , self ejecting, assembly ...	2	—	C	JM3
7122	10-20 R 905	(Mod. 5170) HUB , roller	2	—	C	JM2
28D/9133011	A25/2C	Attachments for 10-20 R 905, Hub :—				
28W/9419402	SP.13/C	Bolt, 2 BA	1	—	C	
		Washer	1	—	C	
	10-20 R 903	ROLLER	2	L.64	LM	JM2
19067	10-20 M 965ND	SPIGOT	2	—	C	JM2
		Attachments for 10-20M965ND, Spigot :—				
28M/1011470	A27/GT	Nut, $\frac{5}{16}$ " BSF	1	—	C	
28W/9419403	SP.13/G	Washer	1	—	C	
		Attachments for 10-20 M 1017A, Bracket :—				
28D/1011029	A25/1E	Bolt, $\frac{1}{4}$ " BSF	4	—	C	
28W/9416316	SP.41/E	Washer, tab	4	—	C	
14A/5886	—	CAMERA , F95 Mk. 4"-4 assembly ...	1	—	P	JM2
		(Service supply and fit)				
	10-20 M 1177A/ND	CAMERA , vertical, assembly	1	—	—	JM2
	10-20 M 961A	Spares for :— BRACKET , mounting, assembly	1	—	—	JM2
19067	10-20 M 965ND	Spares for :— SPIGOT	1	—	C	JM2
		Attachments for 10-20 M 965ND, Spigot :—				
28M/1011470	A27/GT	Nut, $\frac{5}{16}$ " BSF	1	—	C	
28W/9419403	SP.13/G	Washer	1	—	C	
		Attachments for 10-20 M 961A, Bracket :—				
28D/1011029	A25/1E	Bolt, $\frac{1}{4}$ " BSF	2	—	C	
28W/9416316	SP.41/E	Washer, tab	2	—	C	
14A/5886	—	CAMERA , F95 Mk. 4"-4, assembly ...	1	—	P	JM2
		(Service supply and fit)				
	10-20 M 977A	HANDLE , and mounting bracket, assembly	1	—	—	JM2
		Spares for :—				
20407	10-20 M 1521A	FASTENER , self ejecting, assembly	2	—	C	JM2
		(Mod. 5170)				

**EQUIPMENT, SPECIAL OPERATIONAL
PHOTOGRAPHIC RECONNAISSANCE
(SPECIAL ORDER ONLY)**

Ref. No.	Part No.	Description	No. off						Material Specification	Class of Store or LM	Plate No.
			1	2	3	4	5	6			
	10-20 M 1357A	CENTRE SECTION, assembly						1	—	—	JM1
		Spares for :—									
19138	10-20 A 5429	BOLT , eye, pivot for strut						1	—	C	JM1
		Attachments for 10-20 A 5429A, Bolt :—									
28M/13935	A58/ES	Nut, 1/2" BSF						1	—	C	
28P/1011031	SP.9/C10	Pin, split						1	—	C	
26FN/3275	DHS.69/DD	Shim						1	—	C	
	10-20 A 5671ND	Washer, saddle, 10 SWG						1	L.72	LM	JM1
19125	10-20 A 5293	BRACKET , hinge, front						1	—	C	JM1
		Attachments for 10-20 A 5293, Bracket :—									
28D/1013178	AS.1242/5E	Bolt, 2 BA						2	—	C	
38M/1011475	A27/EP	Nut, 2 BA						2	—	C	
28W/9419405	SP.15/E	Washer						2	—	C	
19126	10-20 A 5375	BRACKET , hinge, rear						1	—	C	JM1
		Attachments for 10-20 A 5375, Bracket :—									
28D/1007976	AS.1242/4C	Bolt, 2 BA						2	—	C	
28M/9403520	A27/CP	Nut, 2 BA						2	—	C	
	10-20 A 5665ND	Washer, saddle, 10 SWG						1	L.72	LM	JM1
28W/9419475	SP.15/C	Washer						2	—	C	
	10-20 A 5513A	BRACKET , time delay unit, assembly						1	—	—	JM1
	10-20 A 5515ND	BRACKET , bare 22 SWG						1	L.72	LM	JM1
28M/9434253	AGS.2007/B/1	NUT , 4 BA, anchor						3	—	C	
	10-20 A 5517A	BRACKET , terminal blocks, assembly						1	—	—	JM1
	10-20 A 5519ND	BRACKET , bare, 22 SWG						1	L.72	LM	JM1
28M/9434253	AGS.2007/B/1	NUT , 4 BA, anchor						—	—	C	
	10-20 A 5577	CHANNEL , nose strut stowage, 18 SWG						1	L.72	LM	JM1
	10-20 A 3321	CLEAT , aft, 18 SWG						2	L.72	LM	JM1
	10-20 A 5400	CLEAT , forward, 20 SWG						1	L.72	LM	JM1
	10-20 A 5399	CLEAT , forward, 20 SWG						1	L.72	LM	JM1
	10-20 A 3325	CLEAT , frame, 20 SWG						4	L.72	LM	JM1
	10-20 A 5669ND	CLEAT , frame, 20 SWG						4	L.72	LM	JM1
	10-20 A 5401	CLEAT , rear floor beam, 20 SWG						1	L.72	LM	JM1
	10-20 A 5402	CLEAT , rear floor beam, 20 SWG						1	L.72	LM	JM1
	10-20 A 3293A	COVER , fastener, rear, assembly						2	—	—	JM1
		(For spares use 10-20 A 6113ND)									
19250	10-20 A 6113ND	COVER , fastener, rear (Spares condition)						2	—	C	
19129	10-20 A 5469	COVER , fastener, forward						2	—	C	JM1
19136	KING AIRCRAFT C.14393	FASTENER						4	—	C	JM1
		Attachments for C.14393, Fastener, at latch (Drg. No. 10-20 M 1495) :—									
28D/9140645	A25/10C	Bolt, 2 BA						2	—	C	
28M/10288	AGS.2001/C/1	Nut, 2 BA						2	—	C	
28W/9419404	SP.16/C	Washer						3	—	C	
	10-20 A 3324	FRAME , R.H. (For spares use 10-20 A 6116ND)						1	—	—	JM1
19252	10-20 A 6116ND	FRAME , R.H. (Spares condition)						1	—	C	
	10-20 A 3323	FRAME , L.H. (For spares use 10-20 A 6115ND)						1	—	—	JM1
19251	10-20 A 6115ND	FRAME , L.H. (Spares condition)						1	—	C	
	10-20 A 5359	FRAME , front (For spares use 10-20 A 6111ND)						1	—	—	JM1
19249	10-20 A 6111ND	FRAME , front (Spares condition)						1	—	C	

**EQUIPMENT, SPECIAL OPERATIONAL
PHOTOGRAPHIC RECONNAISSANCE
(SPECIAL ORDER ONLY)**

Ref. No.	Part No.	Description	No. off	Material Specification	Class of Store or L.M.	Plate No.
19124	10-20 A 3285A	FRAME , rear, assembly	1	—	C	JM1
	10-20 A 5637	FRAME , suspension	2	—	—	JM1
	10-20 A 5638	FRAME , suspension	2	—	—	JM1
5K/2939	SP.40/C24	GROMMET	1	—	C	
19137	10-20 A 5427	PIN , locating	4	—	C	JM1
19122	10-20 A 5305	PIN , shear, top casting (Ref. Drg. No. 10-20 A 5609A)	2	—	C	JM2
		Attachments for 10-20 A 5305, Pin :—				
28M/10332	AGS.2002/J/1	Nut, 3/8" BSF	1	—	C	
28W/9419477	SP.15/J	Washer	1	—	C	
	—	PIVOT , hinge, group	1	—	—	
28D/7002427	A25/6G	BOLT , 3/8" BSF	4	—	C	
28M/14537	A58/GS	NUT , 3/8" BSF	4	—	C	
28P/9527619	SP.90/C7	PIN , split (SP.9/C8)	4	—	C	
28W/9419403	SP.13/G	WASHER	4	—	C	
	10-20 A 5653ND	PLATE , reinforcing, forward hinge bracket, 14 SWG	1	L.72	LM	JM1
	—	SEALS , centre-section, group	1	—	—	
		(Drg. No. 10-20 A 5499)				
	10-20 A 5509ND	SEAL (Make from standard section J1021, Ref. No. 26FC/11980)	1	—	LM	JM1
	10-20 A 6511ND	SEAL (Make from standard section J1021, Ref. No. 26FC/11980)	1	—	LM	JM1
19141	10-20 A 5501ND	STRIP , seal retaining, front, lower ...	1	—	C	JM1
19142	10-20 A 5503ND	STRIP , seal retaining, front, upper ...	1	—	C	JM1
		Attachments for 10-20 A 5501ND or 10-20 A 5503ND, Strip :—				
28D/1007979	AS.1246/1B	Bolt, 4 BA	10	—	C	
28M/10327	AGS.2002/B/1	Nut, 4 BA	10	—	C	
28W/9419474	SP.15/B	Washer	10	—	C	
19143	10-20 A 5505ND	STRIP , seal retaining, rear, upper ...	1	—	C	JM1
19145	10-20 A 5506ND	STRIP , seal retaining, rear, lower ...	1	—	C	JM1
		Attachments for 10-20 A 5505ND or 10-20 A 5506ND, Strip :—				
28D/1007979	AS.1246/1B	Bolt, 4 BA	9	—	C	
28M/10327	AGS.2002/B/1	Nuc, 4 BA	9	—	C	
28W/9419474	SP.15/B	Washer	9	—	C	
19144	10-20 A 5507ND	STRIP , seal, retaining, rear, R.H. ...	1	—	C	JM1
		Attachments for 10-20 A 5507ND, Strip :—				
28D/1007979	AS.1246/1B	Bolt, 4 BA	4	—	C	
28M/10327	AGS.2002/B/1	Nuc, 4 BA	4	—	C	
28W/9419474	SP.15/B	Washer	4	—	C	
26FN/3263	DHS.69/EE	SHIM	4	—	C	JM1
	10-20 A 3331ND	SHIM , 1/8" thick, Attewell	4	LA.3	LM	JM1
	—	SHUTTER , and aft window, installation (Drg. No. 10-20 M 1167)	1	—	—	
5K/2869	SP.40/A24	GROMMET	1	—	C	

**EQUIPMENT, SPECIAL OPERATIONAL
PHOTOGRAPHIC RECONNAISSANCE
(SPECIAL ORDER ONLY)**

Ref. No.	Part No.	Description	No. off	Material Specification	Class of Store or LM	Place No.
	10-20 M 1245A	GUIDE , assembly	1	—	—	JM2
		Spares for :—				
19061	10-20 M 1223	CATCH , ball	2	—	C	JM2
19059	10-20 M 1013	RING , retaining window	1	—	C	JM2
		Attachments for 10-20 M 1013, Ring :—				
28S/9435716	A33/B12	Screw, 4 BA	6	—	C	
19057	10-20 M 1009	SEAL , inner, window	1	—	C	JM2
19058	10-20 M 1011	SEAL , outer, window	1	—	C	JM2
19060	10-20 M 1275A	SPRAY , demisting, assembly	1	—	C	JM2
		Attachments for 10-20 M 1275A, Spray :—				
28D/ 28W/9416642	AS.4598/8B SP.47/B	Bolt, 4 BA	2	—	C	
		Washer, spring	2	—	C	
19056	10-20 M 1007	WINDOW , glass	1	—	C	JM2
		Attachments for 10-20 M 1245A, Guide :—				
28M/10325	AGS.2002/B/1	Nut, 4 BA	1	—	C	
28M/10287	AGS.2001/B/1	Nut, 4 BA	8	—	C	
28S/9992521	A33/B24	Screw, 4 BA	1	—	C	
28S/1200065	A33/B28	Screw, 4 BA	8	—	C	
28W/9419401	SP.10/B	Washer	1	—	C	
28W/9419465	SP.13/B	Washer	8	—	C	
19063	10-20 M 1101A	SHUTTER , assembly	1	—	C	JM2
	—	SHUTTER and forward window installation (Drg. No. 10-20 M 1295)	1	—	—	
	10-20 M 1299A	GUIDE , assembly	1	—	—	JM2
		Spares for :—				
19061	10-20 M 1223	CATCH , ball	2	—	C	JM2
19059	10-20 M 1013	RING , retaining, window	1	—	C	JM2
		Attachments for 10-20 M 1013, Ring :—				
28S/9435716	A33/B12	Screw, 4 BA	6	—	C	
19057	10-20 M 1009	SEAL , inner, window	1	—	C	JM2
19058	10-20 M 1011	SEAL , outer, window	1	—	C	JM2
19060	10-20 M 1275A	SPRAY , demisting, window, assembly	1	—	C	JM2
		Attachments for 10-20 M 1275A, Spray :—				
28D/ 28W/9416642	AS.4598/8B SP.47/B	Bolt, 4 BA	2	—	C	
		Washer, spring	2	—	C	
19056	10-20 M 1007	WINDOW , glass	1	—	C	JM2
		Attachments for 10-20 M 1299A, Guide :—				
28D/9131782	AS.1242/2B	Bolt, 4 BA	10	—	C	
19062	10-20 M 1021A	SHUTTER , assembly	1	—	C	JM2
19148	10-20 A 5641	SLEEVE , suspension	1	—	C	JM1
		Attachments for 10-20 A 5641, Sleeve :—				
28D/9133013	A25/5C	Bolt, 2 BA	2	—	C	
28W/9419402	SP.13/C	Washer	2	—	C	
19128	10-20 A 5488	STIFFENER , front	2	—	C	JM1
19127	10-20 A 5487	STIFFENER , front	2	—	C	JM1
	10-20 A 5539	STIFFENER , rear hinge... ..	1	—	—	JM1
		(For spares use 10-20 A 6121ND)				

**EQUIPMENT, SPECIAL OPERATIONAL
PHOTOGRAPHIC RECONNAISSANCE
(SPECIAL ORDER ONLY)**

Ref. No.	Part No.	Description	No. off	Material Specification	Class of Store or L.M	Place No.
19255	10-20 A 6121ND 10-20 A 5540	STIFFENER , rear hinge (Spares condition) ... STIFFENER , rear hinge... ..	1 1	— —	C —	JM1
19256	10-20 A 6122ND 10-20 M 1261A	(For spares use 10-20 A 6122ND) STIFFENER , rear hinge (Spares condition) ... STRUT , nose, assembly	1 1	— —	C —	JM1
28P/1013114 28P/9527619 28W/9419402	SP.4Y/B8 SP.90/C7 SP.13/C	Attachments for 10-20 M 1261A, Strut :— Pin, shackle Pin, split (SP9/C8) Washer	1 1 1	— — —	C C C	
28E/1009753	AS.3180/3C	CLIP , " P," shutter control cable, forward Attachments for AS.3180/3C, Clip :—	1	—	C	
28D/9436920 28M/10328 28W/9419454	A25/1C AGS.2002/C/1 SP.10/C	Bolt, 2 BA Nut, 2 BA Washer	1 1 1	— — —	C C C	
19655	10-20 M 1435A	CONE , rear fairing, assembly Spares for :—	1	—	—	JM1
	10-20 A 5545 10-20 M 1433	CLEAT , 20 SWG CONE , end	2 1	L.72 —	LM —	JM1 JM1
19155	10-20 A 5333	COVER , latch	2	—	C	JM1
19152	10-20 A 5327 10-20 A 5331A	FRAME , rear HINGE , assembly	1 1	— —	C —	JM1 JM1
19254	10-20 A 6119A/ND —	(For spares sue 10-20 A 6119A/ND) HINGE , assembly (Spares condition) MECHANISM , window operating, group (Drg. No. 10-20 M 1093A) Spares for :—	1 1	— —	C —	
28E/9428425	10-20 M 1197ND AS.2294/2 10-20 M 1095A	BRACKET , strut stowage clip, 18 SWG CLIP , strut stowage MECHANISM , assembly	2 2 1	L.72 — —	LM C —	JM1 JM1 JM3
19052 19053 19055	10-20 M 1041A 10-20 M 1049 10-20 M 1059A	Spares for :— CAP , end, assembly CAP , end CABLE , operating, assembly	1 1 1	— — —	C C C	JM3 JM3 JM3
19054	—	ELECTRICAL COMPONENTS (See sub-section EDD)	—	—	—	
28D/9137409 28W/9419475	10-20 M 1053 AS.1246/2C SP.15/C	SPRING Attachments for 10-20 M 1095A, Mechanism :— Bolt, 2 BA Washer	1 4 4	— — —	C C C	JM3
	10-20 M 1181A	STRUT , assembly Spares for :—	1	—	—	JM1
32A/ 28FP/2	S.R.D.E. PS.8784 AVDEL LTD. 3201-0405	CORD , Nylon PIN , " Pip," quick release	QR 2	— —	LM C	
	10-20 A 5319ND 10-20 A 5395ND 10-20 M 5335ND	PACKING , hinge, 18 SWG PLATE , shim, $\frac{1}{16}$ " thick, Attewell PLATE , spigot, 10 SWG	1 2 2	L.72 LA.3 L.72	LM LM LM	JM1 JM1 JM1
19150 19151	10-20 A 5313ND 10-20 A 5315ND 10-20 A 5413	SKIN , L.H. SKIN , R.H. STRIP , packing, 12 SWG	1 1 1	— — L.72	C C C	JM1 JM1 JM1
	DUNLOP DAS.412-12/7 $\frac{1}{2}$ " DUNLOP	HOSE , anti-kink	1	—	—	JM1
19090	DUNLOP DAS.412-10/17"-0 DUNLOP	HOSE , anti-kink	1	—	C	JM1
19091 19654 19783	DAS.412-10/20"-0 10-20 M 1409 10-20 M 1495A	HOSE , anti-kink NOSE , assembly (Pre Mod. 5160) NOSE , assembly (Mod. 5160)	1 1 1	— — —	C P P	JM1 JM1 JM1
	10-20 A 5275A	Spares for :— BRACKET , hinge, assembly (For spares use 10-20 A 6109ND)	1	—	—	JM1

**EQUIPMENT, SPECIAL OPERATIONAL
PHOTOGRAPHIC RECONNAISSANCE
(SPECIAL ORDER ONLY)**

Ref. No.	Part No.	Description 1 2 3 4 5 6	No. off	Material Specification	Class of Store or LM	Plate No.
19248	10-20 A 6109ND	BRACKET , hinge (Spares condition) ...	1	—	C	
	10-20 A 5383ND	PLATE , bearing, 10 SWG	2	S.514	LM	JM1
	10-20 A 5349ND	SHIM , $\frac{1}{16}$ " thick, Attewell	2	LA.3	LM	JM1
	10-20 M 1075A	MECHANISM , shutter operating, forward camera	1	—	—	JM3
		Spares for :—				
19055	10-20 M 1059A	CABLE , operating, assembly	1	—	C	JM3
19052	10-20 M 1041A	CAP , end, assembly	1	—	C I	JM3
19053	10-20 M 1049	CAP , end	1	—	C I	JM3
	—	ELECTRICAL COMPONENTS	—	—	—	
		(See sub-section EDD)				
19054	10-20 M 1053	SPRING	1	—	C	JM3
		Attachments for 10-20 M 1075A, Mechanism :—				
28D/9436920	A25/1C	Bolt, 2 BA	4	—	C	
28W/9419402	SP.13/C	Washer	4	—	C	
	10-20 M 1123	PIPE , air, demisting	1	—	—	JM2
		Attachments for 10-20 M 1123, Pipe :—				
28D/1011022	A25/18C	Bolt, 2 BA	1	—	C	
19050	10-20 Y 9595A	PLATE , capping at connector, top (For storage and transportation purposes only)	1	—	C	JM2

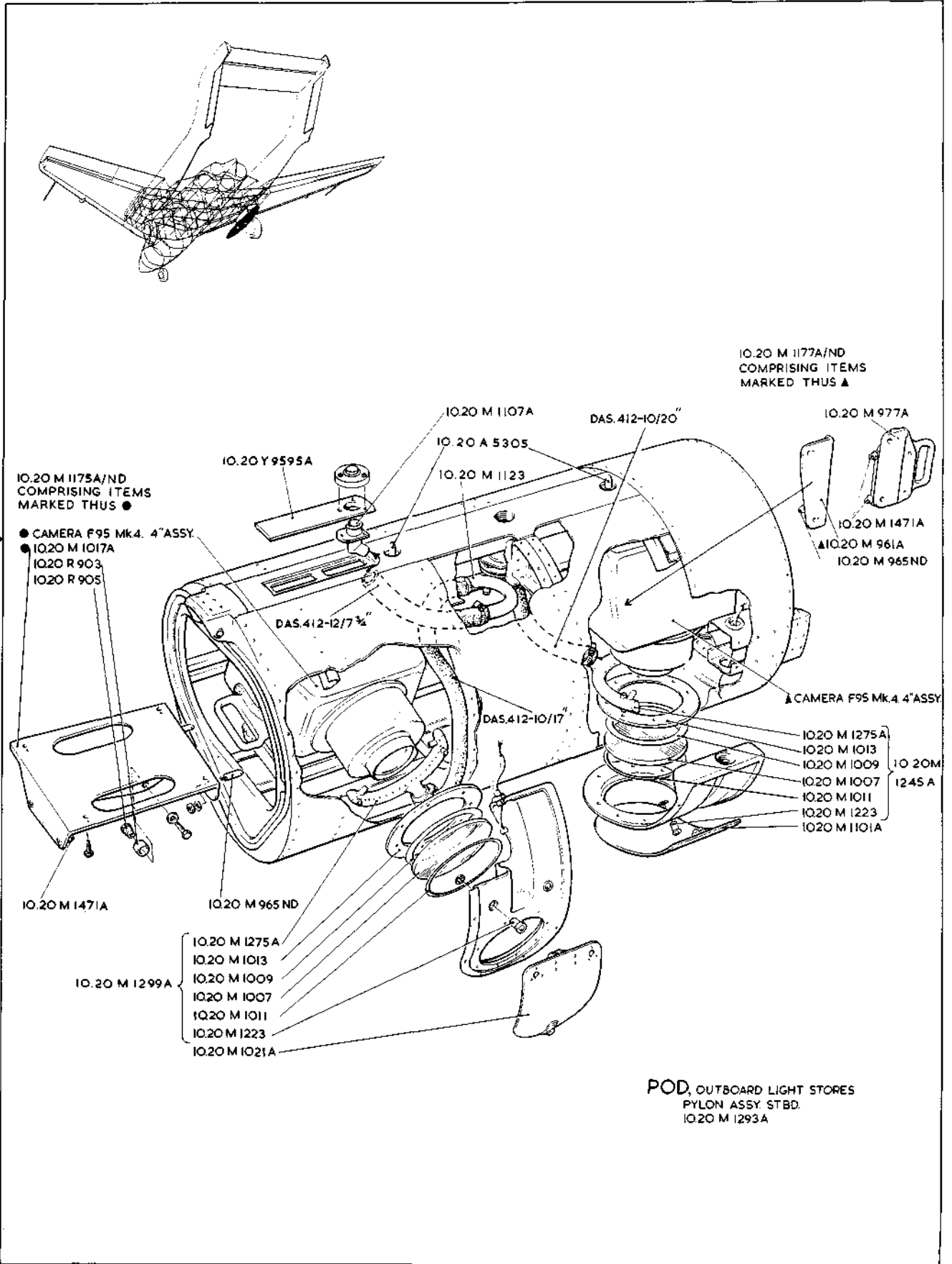

JM. 2

EQUIPMENT, SPECIAL OPERATIONAL

JM. 2

PHOTOGRAPHIC RECONNAISSANCE

[A.L.66]

(SPECIAL ORDER ONLY)

RESTRICTED

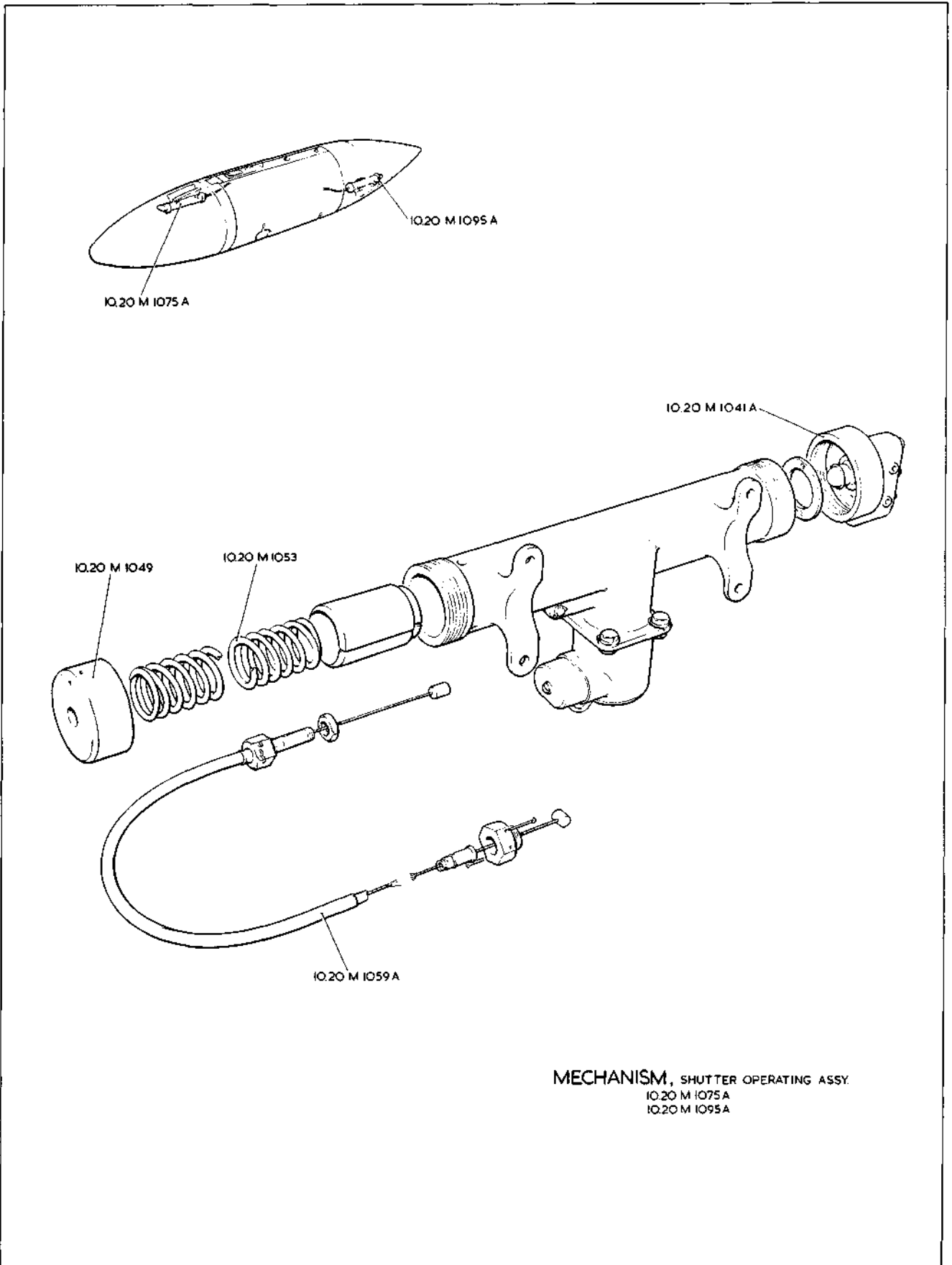

JM.3

EQUIPMENT, SPECIAL OPERATIONAL

JM.3

PHOTOGRAPHIC RECONNAISSANCE

(SPECIAL ORDER ONLY)

[AL60]

This file was downloaded
from the RTFM Library.

Link: www.scottbouch.com/rtfm

Please see site for usage terms,
and more aircraft documents.

