

FUSELAGE

SLIDING HOOD, CANOPY

Ref. No.	Part No.	Description	No. of	Material Specification	Class of Store or L.M	Place No.
198	S10-20 FC 7	HOOD , sliding canopy (Special spares assembly) ...	1	—	P	KE1
	10-20 FC 2223A	HOOD , sliding, canopy, assembly (Mod. 1228) ...	1	—	—	KE1
		Spares for :—				
1870	10-20 FC 627A	ADJUSTER , canopy optimum angle release anchor	1	—	P	KE2
	10 FC 321	BARREL	1	DTD.364	—	KE2
	10-20 FC 723	SCREW , adjuster	1	S.1	—	KE2
	10 FC 319	WASHER	1	S.1	—	KE2
		Attachments for 10-20 FC 627A, Adjuster :—				
28M/1202769	A58/NT	Nut, 1/2" BSF	1	—	C	
1871	10 FC 323	Screw, 3/8" BSF	2	—	C	KE2
1868	10 FC 313	ANCHOR , canopy optimum angle	1	—	C	KE2
		Attachments for 10 FC 313, Anchor :—				
1869	10 FC 331	Bush, pivot	1	—	C	KE2
28P/1076	SP.4Y/F24	Pin, shackle	1	—	C	
28P/9527619	SP.90/C7	Pin, split (SP.9/C8)	1	—	C	
28W/9419403	SP.13/G	Washer	1	—	C	
	10-20 FC 1113ND	ANGLE , stiffening, across rear fairing diaphragm	1	L.72	—	KE2
	10-20 FC 589	ARCH , centre	1	RZ.5	—	KE1
		Attachments for 10-20 FC 589, Arch :—				
28D/1213843	AS.3294/4C	Bolt, 2 BA	4	—	C	
28D/1213847	AS.3294/8C	Bolt, 2 BA	4	—	C	
28M/1006473	A27/CT	Nut, 2 BA	4	—	C	
28M/10328	AGS.2002/C/1	Nut, 2 BA	4	—	C	
28W/9419454	SP.10/C	Washer	8	—	C	
	10-20 FC 575	ARCH , forward	1	RZ.5	—	KE1
		Attachments for 10-20 FC 575, Arch :—				
28D/1213844	AS.3294/5C	Bolt, 2 BA	4	—	C	
28D/1213847	AS.3294/8C	Bolt, 2 BA	2	—	C	
28D/1213850	AS.3294/11C	Bolt, 2 BA	4	—	C	
28M/1006473	A27/CT	Nut, 2 BA	6	—	C	
28M/10288	AGS.2001/C/1	Nut, 2 BA	4	—	C	
28W/9419454	SP.10/C	Washer	10	—	C	
	10-20 FC 1687A	ARCH , rear, assembly	1	—	—	KE1
	10-20 FC 1247	ARCH	1	RZ.5	—	KE1
	10-20 FC 1685	BRACKET	1	L.72	—	KE1
		Attachments for 10-20 FC 1685, Bracket :—				
28D/9706373	A25/2A	Bolt, 6 BA	2	—	C	
28M/10286	AGS.2001/A/1	Nut, 6 BA	2	—	C	
	PARKER KALON					
28S/8544	Type Z	Screw, No. 4 x 3/16"	1	—	C	
28W/9419446	SP.10/A	Washer	2	—	C	
		Attachments for 10-20 FC 1687A, Arch :—				
	10-20 FC 1349ND	Block, packing, Port	1	LFS.26	LM	KE1
	10-20 FC 1345ND	Block, packing, Starboard	1	LFS.26	LM	KE1
28D/1213844	AS.3294/5C	Bolt, 2 BA	9	—	—	
28D/1213845	AS.3294/6C	Bolt, 2 BA	1	—	C	
28D/1213849	AS.3294/10C	Bolt, 2 BA	4	—	C	
28D/1214351	AS.3297/11C	Bolt, 2 BA	2	—	C	
28D/1215512	AS.4563/5C	Bolt, 2 BA	3	—	C	
28M/1006473	A27/CT	Nut, 2 BA	12	—	C	
28W/9419454	SP.10/C	Washer	12	—	C	

FUSELAGE

SLIDING HOOD, CANOPY

Ref. No.	Part No.	Description	No. off	Material Specification	Class of Store or L.M	Plate No.
3403	10-20 FC 1445	BRACKET , hinge, rear end fairing and optimum angle release hook	1	—	C	KE2
		Attachments for 10-20 FC 1445, Bracket :—				
4171	A25/3C/DHS.514/D	Bolt, 2 BA (Alternative S21/A25/3C)	1	—	C	KE2
28D/1213841	AS.3294/2C	Bolt, 2 BA	6	—	C	
28D/1213843	AS.3294/4C	Bolt, 2 BA	2	—	C	
28M/1006473	A27/CT	Nut, 2 BA	4	—	C	
28M/10328	AGS.2002/C/1	Nut, 2 BA	4	—	C	
	10-20 FC 1117ND	Plate, packing, 12 SWG	1	L.72	LM	KE2
13937	10-20 FC 1799ND	Shim, packing, Attewell	1	—	C	KE2
13938	10-20 FC 1803ND	Shim, packing, Attewell	1	—	C	KE2
28W/9419475	SP.15/C	Washer	4	—	C	
1872	10-20 FC 623	BUSH , threaded, optimum angle release anchor adjuster	1	—	C	KE2
		Attachments for 10-20 FC 623, Bush :—				
28D/1214641	AS.3296/3B	Bolt, 4 BA	3	—	C	
28M/10327	AGS.2002/B/1	Nut, 4 BA	3	—	C	
	10-20 FC 625	Plate, bearing (For spares use 10-20 FC 1593ND)	1	L.72	—	KE.2
1873	10-20 FC 1593ND	Plate, bearing (Spares condition)	1	—	C	
	10-20 FC 1401ND	Plate, packing, 10 SWG	1	L.72	LM	KE2
	10-20 FC 1399ND	Plate, packing, 20 SWG	1	L.72	LM	KE2
28W/9419474	SP.15/B	Washer	3	—	C	
33C/9436930	—	CEMENT , "Perspex." Tensol No. 6, for application to all exposed edges of glass fibre attachment pieces on "Perspex" panels	QR	—	C	
	10-20 FC 1467A/ND	CHANNEL , outer, for aft air duct, assembly ...	1	—	—	KE1 KE2 KE2
	10-20 FC 1265ND	CHANNEL ,	1	L.72	—	KE2
28M/13774	AGS.2019/B/1	NUT , anchor, 4 BA	1	—	C	
	10-20 FC 1115ND	CHANNEL , rear fairing diaphragm	1	L.72	—	KE2
	10-20 FC 675ND	CORNER-PIECE , at junction of rear fairing diaphragm to skin stiffener, Port, 20 SWG	1	L.72	LM	KE1
	10-20 FC 677ND	CORNER-PIECE , at junction of rear fairing diaphragm to skin stiffener, Starboard, 20 SWG	1	—	LM	KE1
	10-20 FC 1221A/ND	COVER , forward air duct	1	L.72	—	KE1 KE2
		Attachments for 10-20 FC 1221A/ND, Cover :—				
28S/1213942	PARKER KALON Type A	Screw, No. 4 x 1/4"	10	—	C	
	10-20 FC 1319ND	DIAPHRAGM , rear fairing... ..	1	L.72	—	KE2
	10-20 FC 817ND	DUCT , air, around front arch, L.H.	1	L.72	LM	KE1
	10-20 FC 819ND	DUCT , air, around front arch, R.H.	1	L.72	LM	KE1
		Attachments for 10-20 FC 817ND or 10-20 FC 819ND, Duct :—				
28S/1214087	PARKER KALON Type Z	Screw, No. 4 x 3/8"	QR	—	C	

FUSELAGE
SLIDING HOOD, CANOPY

Ref. No.	Part No.	Description	No. off	Material Specification	Class of Score or L.M	Plate No.
	10-20 FC 1223A/ND	DUCT , forward, between forward and centre arches	1	L.72	—	KE1
28M/12099	AGS.2007/B/3	Spares for :—				KE2
	10-20 FC 1461ND	NUT , anchor, 4 BA	1	—	C	
		WASHER , profile (Make from Standard Section J.2039)	1	DTD.746	LM	KE1
	10-20 FC 1371A/ND	FAIRING , forward portion, assembly	1	—	—	KE1
		Spares for :—				
	10-20 FC 1495ND	ANGLE , edge member attachment, Port ...	1	L.72	—	KE1
	10-20 FC 1497ND	ANGLE , edge member attachment, Starboard	1	L.72	—	KE1
		Attachments for 10-20 FC 1371A/ND, Fairing :—				
28D/1213842	AS.3294/3C	Bolt, 2 BA	3	—	C	
28D/1214472	AS.3297/3C	Bolt, 2 BA	3	—	C	
28D/1214478	AS.3297/10C	Bolt, 2 BA	4	—	C	
28M/10328	AGS.2002/C/1	Nut, 2 BA	10	—	C	
28W/9419454	SP10/C	Washer	10	—	C	
1877	10-20 FC 1351A	FAIRING , rear portion, assembly	1	—	P	KE1
		Spares for :—				
28FP/661	DZUS EFR5/50A	FASTENER	4	—	C	KE2
	10-20 FC 1469A	PLATE , hinge, assembly	1	—	—	KE2
1878	10-20 FC 1389A	PLATE , hinge, L.H., assembly	1	—	P	KE2
1879	10-20 FC 1390A	PLATE , hinge, R.H., assembly	1	—	P	KE2
		Spares for :—				
2036	DHS.418/1/C/15	BUSH (See Repair section PA)	2	—	C	KE2
	10-20 FC 1471ND	STIFFENER , 16 SWG	1	L.73	LM	KE2
		Attachments for 10-20 FC 1469A, Plate :—				
28D/1214470	AS.3297/1C	Bolt, 2 BA	2	—	C	
28D/1214471	AS.3297/2C	Bolt, 2 BA	6	—	C	
28M/1010997	A24/CT	Nut, 2 BA	8	—	C	
28W/9128924	SP.14/C	Washer	8	—	C	
	10-20 FC 1415ND	SEAL , rubber (Make from standard section J.337, Ref. No. 26FN/1431)	1	—	LM	KE1
		Attachments for 10-20 FC 1351A, Fairing :—				
28P/833	SP.4Y/B7	Pin, shackle	2	—	C	
28P/9527619	SP.90/C7	Pin, split (SP.9/C8)	2	—	C	
2034	DHS.776/C/1	Washer	2	—	C	KE1
1858	10-20 FC 831	FAIRING , top, forward air duct exhaust ...	1	—	C	KE1
		Attachments for 10-20 FC 831, Fairing :—				
28D/7002428	A25/6C	Bolt, 2 BA	3	—	C	
28D/1010030	A25/7C	Bolt, 2 BA	1	—	C	
28D/9140644	A25/9C	Bolt, 2 BA	1	—	C	
28D/9133014	A25/13C	Bolt, 2 BA	1	—	C	
28D/18716	AS.3295/21C	Bolt, 2 BA	1	—	C	
28M/10328	AGS.2002/C/1	Nut, 2 BA	1	—	C	
28W/9419454	SP.10/C	Washer	7	—	C	
28FP/611	DZUS R.5	FASTENER , receptacle, fairing rear portion attachment	4	—	C	KE2

FUSELAGE
SLIDING HOOD, CANOPY

Ref. No.	Part No.	Description	No. off						Material Specification	Class of Score or L.M	Place No.
			1	2	3	4	5	6			
	10-20 FC 2429A	PAD , pressure, assembly (Mod. 1562) ...	1						—	—	KE2
	10-20 FC 2425ND	Pad, pressure ...	1					Neoprene	—	LM	
	10-20 FC 2427ND	Plate, backing, 20 SWG ...	1					L.72	—	LM	
		Attachments for 10-20 FC 2429A, Pad :—									
28S/9139154	A25/B20	Screw, 4 BA ...	2					—	—	C	
28M/12619	A24/BT	Nut, 4 BA ...	2					—	—	C	
28W/1206041	AGS.2035/B	Washer, shakeproof ...	2					—	—	C	
1862	10-20 FC 1119ND	PAD , rubber, centre arch ...	1					—	—	C	KE1
17924	10-20 FC 2229A	PANEL , "Perspex," aft (Mod. 1228) ...	1					—	—	C	KE1
		Attachments for 10-20 FC 2229A, Panel :—									
28D/1213847	AS.3294/8C	Bolt, 2 BA ...	2					—	—	C	
28D/1213849	AS.3294/10C	Bolt, 2 BA ...	2					—	—	C	
28D/1215512	AS.4563/5C	Bolt, 2 BA ...	52					—	—	C	
28D/1215510	AS.4563/6C	Bolt, 2 BA ...	1					—	—	C	
28D/1215509	AS.4563/7C	Bolt, 2 BA ...	1					—	—	C	
28D/1215508	AS.4563/8C	Bolt, 2 BA ...	17					—	—	C	
28D/1215506	AS.4563/10C	Bolt, 2 BA ...	1					—	—	C	
28M/1006473	A27/CT	Nut, 2 BA ...	6					—	—	C	
28M/10328	AGS.2002/C/1	Nut, 2 BA ...	69					—	—	C	
28W/9419454	SP.10/C	Washer ...	75					—	—	C	
17925	10-20 FC 2231A	PANEL , "Perspex," forward (Mod. 1228) ...	1					—	—	C	KE1
		Attachments for 10-20 FC 2231A, Panel :—									
28D/1215512	AS.4563/5C	Bolt, 2 BA ...	48					—	—	C	
28D/1215509	AS.4563/7C	Bolt, 2 BA ...	2					—	—	C	
28D/1215508	AS.4563/8C	Bolt, 2 BA ...	30					—	—	C	
28M/10319	AGS.2002/C/3	Nut, 2 BA ...	15					—	—	C	
28M/10328	AGS.2002/C/1	Nut, 2 BA ...	65					—	—	C	
28W/9419454	SP.10/C	Washer ...	65					—	—	C	
1874	10-20 FC 1393A	PIN , hinge, rear end fairing, assembly ...	2					—	—	C	KE2
2035	DHS.4181/C/19	BUSH (See Repair section PA) ...	2					—	—	C	KE2
	10-20 FC 1391ND	PIN , hinge ...	1					S.1	—	—	KE2
	10-20 FC 1443ND	PLUG ...	1					S.1	—	—	KE2
1866	10-20 FC 1093A/ND	PLATE , cover, access to optimum angle release and auto-stabilizer test points	1					—	—	C	KE1
		Attachments for 10-20 FC 1093A/ND, Plate :—									
28D/1213840	AS.3294/1C	Bolt, 2 BA ...	8					—	—	C	
	10-20 FC 1263ND	PLATE , cover, for aft air duct ...	1					—	—	LM	KE2
		Attachments for 10-20 FC 1263ND, Plate :—									
28S/9508320	PARKER KALON Type Z	Screw, No. 4 x 1/4" ...	35					—	—	C	
	10-20 V 2249	PLATE , cover, diffuser plate, aft air duct, 20 SWG	1					L.72	—	LM	KE2
		Attachments for 10-20 V 2249, Plate :—									
28D/1218385	AS.1248/2B	Bolt, 4 BA ...	1					—	—	C	
19716	10-20 V 2217ND	Washer, red fibre, 3/8" o/d x 0"-15 i/d x 1/16" ...	1					BSS.216	—	C	KE2
	10-20 V 2247	PLATE , cover, diffuser plate, forward air duct, 20 SWG	1					L.72	—	LM	KE2
		Attachments for 10-20 V 2247, Plate :—									
28D/1218386	AS.1248/3B	Bolt, 4 BA ...	1					—	—	C	
19716	10-20 V 2217ND	Washer, red fibre, 3/8" o/d x 0"-15 i/d x 1/16" ...	1					BSS.216	—	C	KE2

FUSELAGE

SLIDING HOOD, CANOPY

Ref. No.	Part No.	Description	No. off						Material Specification	Class of Store or L.M.	Plate No.
			1	2	3	4	5	6			
5568	10-20 V 2233A	PLATE , diffuser, aft air duct, assembly Attachments for 10-20 V 2233A, Plate :—	...	1	—	—	—	—	C	KE2	
28S/6233	PARKER KALON Type Z	Screw, No. 4 × 1/4"	1	—	—	—	—	C		
28S/9508320	PARKER KALON Type Z	Screw, No. 4 × 1/4"	2	—	—	—	—	C		
5567	10-20 V 2231A	PLATE , diffuser, forward air duct, assembly Attachments for 10-20 V 2231A, Plate :—	...	1	—	—	—	—	C	KE2	
28S/1213930	PARKER KALON Type A	Screw, No. 4 × 1/4"	1	—	—	—	—	C		
28S/1213942	PARKER KALON Type A	Screw, No. 4 × 1/4"	2	—	—	—	—	C		
	10-20 FC 1779	PLATE , fairing, at forward air duct (Mod. 260) Attachments for 10-20 FC 1779, Plate	...	1	—	—	—	—	—	KE2	
28S/1213930	PARKER KALON Type A	Screw, No. 4 × 1/4"	2	—	—	—	—	C		
28S/6810	PARKER KALON Type Z	Screw, No. 4 × 3/8" (Pre Mod. 1352)	2	—	—	—	—	C		
	10-20 FC 613ND	PLATE , fillet, forward end of aft air duct	1	L.72	—	—	—	LM	KE2	
	10-20 FC 1367A/ND	PLATE , nut, access cover plate attachment, assembly Spares for :—	...	1	—	—	—	—	LM	KE1	
28M/11957	AGS.2007/C/1	NUT , anchor	8	—	—	—	—	C		
	10-20 FC 609ND	PLATE , packing, forward end of aft air duct	1	L.72	—	—	—	LM	KE2	
	10-20 FC 601ND	PLATE , reinforcing, aft air duct cover plate Attachments for 10-20 FC 601ND, Plate	...	1	L.72	—	—	—	LM	KE2	
28S/6775	PARKER KALON Type Z	Screw, No. 4 × 1/4"	3	—	—	—	—	C		
1876	10-20 FC 1397	PLATE , saddle, hinge bracket Attachments for 10-20 FC 1397, Plate :—	...	2	—	—	—	—	C	KE2	
5612	A25/1B/DHS.514/D	Bolt, 4 BA (Alternative S21/A25/1B)	2	—	—	—	—	C	KE2	
	10-20 FC 1269ND	PLUG-END , at aft end of aft air duct Attachments for 10-20 FC 1269ND, Plug-end :—	...	1	LFS.21	—	—	—	LM	KE2	
28S/6775	PARKER KALON Type Z	Screw, No. 4 × 1/2"	3	—	—	—	—	C		
28S/1214834	PARKER KALON Type Z	Screw, No. 4 × 1/2"	2	—	—	—	—	C		
	10-20 FC 990ND 989ND	PLUG-END , at forward end of aft air duct, L.H.	...	1	LFS.21	—	—	—	LM	KE2	
	10-20 FC 990ND	PLUG-END , at forward end of aft air duct, R.H.	...	1	LFS.21	—	—	—	LM	KE2	
	10-20 FC 833ND	PLUG , in end of air duct around forward arch, L.H.	...	1	LFS.21	—	—	—	LM	KE1	
	10-20 FC 835ND	PLUG , in end of air duct around forward arch, R.H.	...	1	LFS.21	—	—	—	LM	LE1	
19094	10-20 FC 805	RUNNER , Port, assembly Spares for :—	...	1	—	—	—	—	C	KE1	
26FC/2870	A.001687	PIN , securing, double roller	5	—	—	—	—	C	KE1	
1860	10 FC 115	PIN , securing, single roller	4	—	—	—	—	C	KE1	
26FC/2867	A.001684	ROLLER , horizontal	5	—	—	—	—	C	KE1	
26FC/2866	A.001683	ROLLER , horizontal	9	—	—	—	—	C	KE1	
9802	10-20 FC 1587	ROLLER , vertical...	5	—	—	—	—	C		
1859	10-20 FC 1111	ROLLER , vertical...	5	—	—	—	—	C	KE1	
		Attachments for 10-20 FC 1587 or 10-20 FC 1111, Roller :—	...								
20280	10-20 FC 5399	Bolt, roller	1	—	—	—	—	C	KE1	
28M/1006473	A27/CT	Nut, 2 BA	1	—	—	—	—	C		
28VV/9419454	SP.10/C	Washer	1	—	—	—	—	C		

**FUSELAGE
SLIDING HOOD, CANOPY**

Ref. No.	Part No.	Description	No. off						Material Specification	Class of Store or LM	Place No.
			1	2	3	4	5	6			
19093	10-20 FC 803A	RUNNER , Starboard, assembly						1	—	P	KE1
		Spares for :—									
26FC/2870	A.001687	PIN , securing						4	—	C	KE1
1861	10-20 FC 1049	PIN , securing						5	—	C	KE1
26FC/2867	A.001684	ROLLER , horizontal, lower						9	—	C	KE1
26FC/2856	A.001683	ROLLER , horizontal, upper						9	—	C	KE1
1859	10-20 FC 1111	ROLLER , vertical						10	—	C	KE1
		Attachments for 10-20 FC 1111, Rioller :—									
26FC/2872	3 FC 481	Bolt						1	—	C	KE1
28M/1006473	A27/CT	Nut, 2 BA						1	—	C	
28W/9419454	SP.10/C	Washer						1	—	C	
	10-20 FC 1807ND	SEAL , fairing, L.H. (Make from Ref. No. 32C/665)						1	—	LM	KE1
		Attachments for 10-20 FC 1807ND, Seal :—									
	10-20 FC 1333ND	Strip, 20 SWG						1	L.72	LM	KE1
	10-20 FC 1805ND	SEAL , fairing, R.H. (Make from Ref. No. 32C/665)						1	—	LM	KE1
		Attachments for 10-20 FC 1805ND, Seal :—									
	10-20 FC 1339ND	Strip, 20 SWG						1	L.72	LM	KE1
13936	10-20 FC 1801ND	SHIM , packing, between rear of fairing hinge bracket and diaphragm, Attewell						1	—	C	KE2
7118	10-20 FC 1563	SPRING , rear end fairing hinge						2	—	C	KE2
	10-20 FC 1267ND	STIFFENER , aft air duct						1	L.72	—	KE2
	10-20 FC 669ND	STIFFENER , fairing, forward portion						1	L.72	—	KE1
	10-20 FC 1331ND	STIFFENER , fairing, forward portion, L.H.						1	L.72	—	KE1
	10-20 FC 1325ND	STIFFENER , fairing, forward portion, top centre						1	L.72	LM	KE2
16663	10-20 FC 2193A	STOP , opening, assembly (Mod. 1018)						1	—	C	KE1
		Spares for :—									
	10-20 FC 2197ND	PAD , buffer, natural rubber, ".7 x ".62 x $\frac{1}{8}$ " thick, Shore hardness 60°						1	—	LM	KE1
		Attachments for 10-20 FC 2193A, Stop :—									
28D/1214299	AS.1242/5B	Bolt, 4 BA						2	—	C	
28D/1213846	AS.3294/7C	Bolt, 2 BA						1	—	C	
28M/10328	AGS.2002/C/1	Nut, 2 BA						1	—	C	
28W/9419475	SP.15/C	Washer						1	—	C	
	10-20 FC 1327ND	STRAP , fairing, forward portion, top centre						1	L.72	LM	KE2
1863	10-20 FC 1121ND	STRIP , leather, centre arch pad, covering						1	—	C	KE1
	10-20 FC 2227A/ND	STRIP , masking, centre arch, assembly (Mod. 1228) (For spares use 10-20 FC 2233A/ND)						1	L.72	—	KE1
17926	10-20 FC 2233A/ND	STRIP , masking, centre arch, assembly (Spares condition)						1	—	C	
		Attachments for 10-20 FC 2227A/ND, Strip :—									
28D/1213851	AS.3294/12C	Bolt, 2 BA						2	—	C	
28D/1215510	AS.4563/6C	Bolt, 2 BA						1	—	C	
28D/1215504	AS.4563/15C	Bolt, 2 BA						23	—	C	
28M/1006473	A27/CT	Nut, 2 BA						2	—	C	
26FC/11368	15 FC 3253	Nipple, 2 BA						2	—	C	KE1
28M/10328	AGS.2002/C/1	Nut, 2 BA						22	—	C	
28W/9419454	SP.10/C	Washer						24	—	C	
	—	WINDOW , rear fairing, group (Drg. No. 10-20 FC 2205A) (Mod. 1091)						1	—	—	KE1
	10-20 FC 5205A/ND	RING , reinforcing, assembly						1	—	—	KE1
		Spares for :—									
28M/9434251	AGS.2007/B/1	NUT , 4 BA, anchor						9	—	C	
17512	10-20 FC 5203ND	WINDOW , perspex, $\frac{1}{8}$ " thick						1	—	C	KE1
		Attachments for 10-20 FC 5203ND, Window :—									
28D/8337	AS.1248/1B	Bolt, 4 BA						9	—	C	

SEE TEXT FOR SPARES CONDITION OF ITEMS MARKED WITH * *

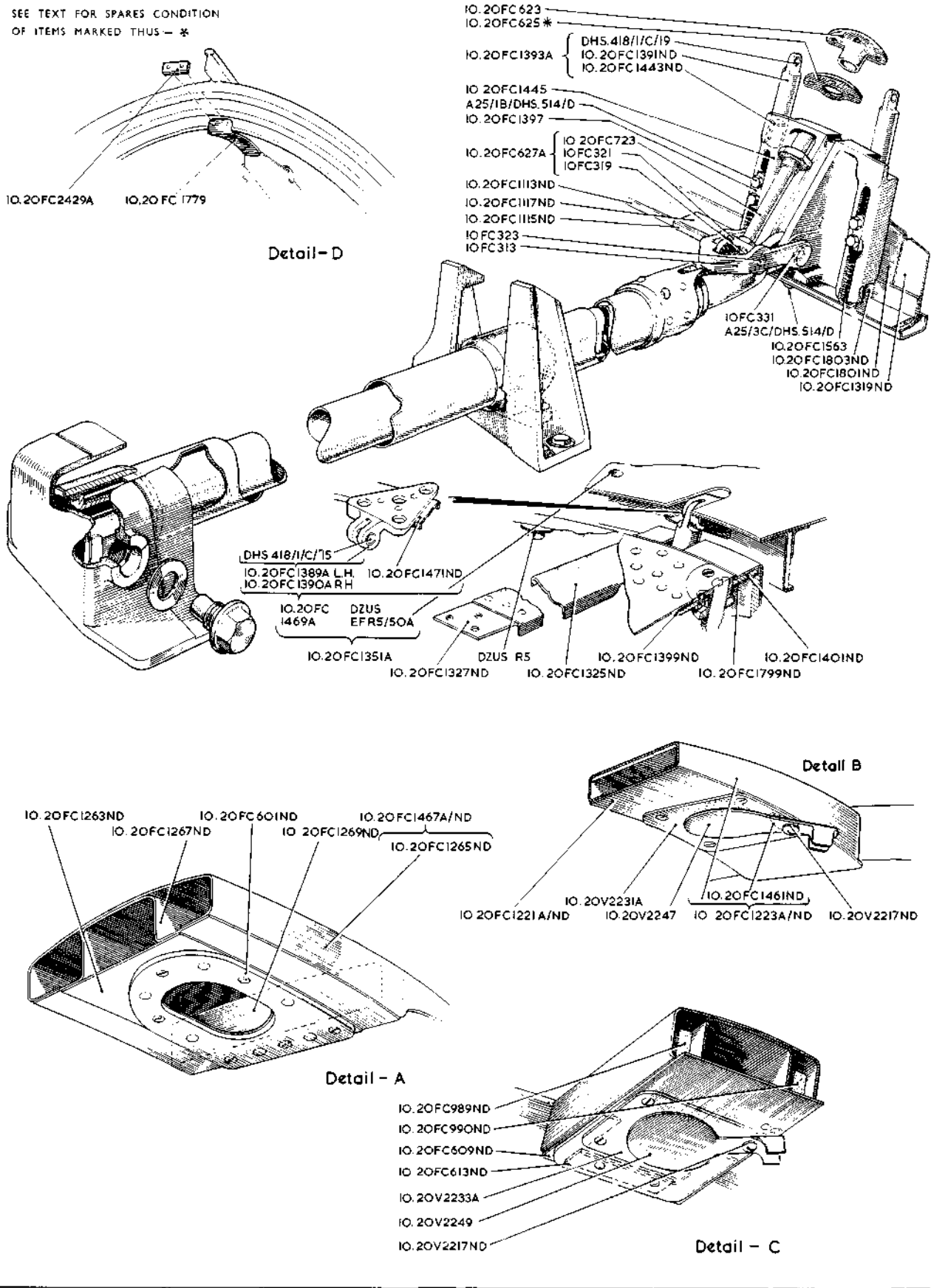

Detail - D

Detail B

Detail - A

Detail - C



This file was downloaded
from the RTFM Library.

Link: www.scottbouch.com/rtfm

Please see site for usage terms,
and more aircraft documents.