

FUSELAGE

FUSELAGE AIR BRAKE

Ref. No.	Part No.	Description	No. off	Material Specification	Class of Store or LM	Place No.
		INSTALLATION OF FUSELAGE AIR BRAKE (Drg. No. 10-20 WB 1069)	1	—	—	
129	S10-20 WB 4	AIR-BRAKE , fuselage (Special spares assembly) ... (Mod. 457)	1	—	P	KH1
	10-20 WB 1899A	AIR-BRAKE , fuselage, assembly (Mod. 457) ...	1	—	—	KH1
	10-20 WB 2067	BRACKET , air brake, stn. 192"-5 to 197"-05 (For spares use 10-20 WB 2239ND)	1	DTD.304	—	KH1
15656	10-20 WB 2239ND	BRACKET , air brake, stn. 192"-5 to 197"-05 (Spares condition)	1	—	C	
	10-20 WB 1521	CAM , fairing, hinge (For spares use 10-20 WB 5001ND)	1	L.64	—	KH2
17115	10-20 WB 5001ND	CAM , fairing, hinge (Spares condition) ... Attachment for 10-20 WB 1521, Cam :-	1	—	C	
28D/1214299	AS.1242/5B	Bolt, 4 BA ...	1	—	C	
28M/9403519	A27/BP	Nut, 4 BA ...	1	—	C	
28W/9419474	SP.15/B	Washer ...	1	—	C	
	10-20 WB 1595ND	CLEAT , rear frame, 20 SWG ...	1	L.72	LM	KH1
	10-20 WB 1596ND	CLEAT , rear frame, 20 SWG ...	1	L.72	LM	KH1
17251	10-20 WB 1407A	COUPLING , jack attachment, assembly ... Spares for :-	1	—	P	KH2
17623	10-20 WB 5005	BOLT , special, $\frac{5}{16}$ " BSF (Mod. 1222) ...	2	—	C	KH2
7791	10-20 WB 1419	CIRCLIP ...	1	—	C	KH2
7792	10-20 WB 1577A	COUPLING , jack attachment, assembly ...	1	—	C	KH2
7789	10-20 WB 1415	LOCKNUT ...	2	—	C	KH2
28N/9156370	SP.21	NIPPLE , lubrication (Mod. 1222) ...	2	—	C	KH2
7787	10-20 WB 1411	SLEEVE , outer ...	1	—	C	KH2
17624	10-20 WB 5019A	TRUNNION and bush, assembly ... (Mod. 1222)	1	—	C	KH2
28W/1206062	AGS.2034/N	WASHER , shakeproof ...	2	—	C	
	10-20 WB 1529ND	DIAPHRAGM , Port (For spares use 10-20 WB 1815ND)	1	L.72	—	KH1
10407	10-20 WB 1815ND	DIAPHRAGM , Port (Spares condition) ...	1	—	C	
	10-20 WB 1530ND	DIAPHRAGM , Starboard (For spares use 10-20 WB 1816ND)	1	L.72	—	KH1
10408	10-20 WB 1816ND	DIAPHRAGM , Starboard (Spares condition)	1	—	C	
	10-20 WB 1591ND	DIAPHRAGM , Port (For spares use 10-20 WB 1813ND)	1	L.72	—	KH1
10405	10-20 WB 1813ND	DIAPHRAGM , Port (Spares condition) ...	1	—	C	
	10-20 WB 1592ND	DIAPHRAGM , Starboard (For spares use 10-20 WB 1814ND)	1	L.72	—	KH1
10406	10-20 WB 1814ND	DIAPHRAGM , Starboard (Spares condition)	1	—	C	
	10-20 WB 1593ND	DIAPHRAGM , Port (For spares use 10-20 WB 1807ND)	1	L.72	—	KH1
10399	10-20 WB 1807ND	DIAPHRAGM , Port (Spares condition) ...	1	—	C	
	10-20 WB 1594ND	DIAPHRAGM , Starboard (For spares use 10-20 WB 1808ND)	1	L.72	—	KH1
10400	10-20 WB 1808ND	DIAPHRAGM , Starboard (Spares condition)	1	—	C	

FUSELAGE
FUSELAGE AIR BRAKE

Ref. No.	Part No.	Description	No. off						Material Specification	Class of Score or L.M	Plate No.
			1	2	3	4	5	6			
7748	10-20 WB 1247	DOUBLER , inner Attachments for 10-20 WB 1247, Doubler :—						1	—	C	KH1
28D/9133011	A25/2C	Bolt, 2 BA						1	—	C	
28D/1010030	A25/7C	Bolt, 2 BA						22	—	C	
28D/1008151	A25/4E	Bolt, 1/4" BSF						6	—	C	
28D/1011240	A25/5E	Bolt, 1/4" BSF						8	—	C	
28D/1008145	A25/6E	Bolt, 1/4" BSF						10	—	C	
28D/1011247	A25/13E	Bolt, 1/4" BSF						4	—	C	
28D/1011248	A25/16E	Bolt, 1/4" BSF						2	—	C	
28D/1011257	A25/7G	Bolt, 3/8" BSF						10	—	C	
28M/9403520	A27/CP	Nut, 2 BA						12	—	C	
28M/10288	AGS.2001/C/1	Nut, 2 BA						4	—	C	
28M/5808573	A27/CS	Nut, 2 BA						2	—	C	
28M/1011475	A27/EP	Nut, 1/4" BSF						6	—	C	
28M/1011467	A27/ES	Nut, 1/4" BSF						18	—	C	
28M/5808571	A27/GS	Nut, 3/8" BSF						10	—	C	
28P/9527619	SP.90/C7	Pin, split (SP.9/C8)						30	—	C	
28W/9419475	SP.15/C	Washer						16	—	C	
28W/9419405	SP.15/E	Washer						24	—	C	
28W/9419488	SP.16/G	Washer						10	—	C	
	10-20 WB 1605A	DOUBLER , outer, assembly (For spares use 10-20 WB 1753A/ND)						1	—	—	KH1
10391	10-20 WB 1753A/ND	DOUBLER , outer, assembly (Spares condition)						1	—	C	
15033	10-20 WB 1955A	FAIRING , bottom, fixed, assembly Attachments for 10-20 WB 1955A, Fairing :—						1	—	C	KH2
		Bolt, 2 BA						1	—	C	KH1
1092	DHS.365/2C	Bolt, 2 BA						2	—	C	
28D/1215078	AS.1246/5C	Bolt, 2 BA						3	—	C	
28D/9436920	A25/1C	Bolt, 2 BA									
15034	10-20 WB 1953A	FAIRING , hinged, assembly (Pre Mod. 1238)						1	—	C	KH2
19685	10-20 WB 5043A	FAIRING , hinged, assembly (Mod. 1238) Spares for :—						1	—	C	KH2
28FP/1018	DZUS F6/T53	FASTENER , supersonic						1	—	C	KH2
28FP/9140768	DZUS GH/6	GROMMET						1	—	C	KH2
26FC/11980	J.1021	STRIP , sealing, standard section (Required to make sealing strips)						QR	—	C	KH2
	10-20 WB 1257A	FRAME , stn. 180"-9, assembly (For spares use 10-20 WB 1823A/ND)						1	—	—	KH1
10701	10-20 WB 1823A/ND	FRAME , stn. 180"-9, assembly (Spares condition)						1	—	C	
	10-20 WB 1277A	FRAME , stn. 186"-7, assembly (For spares use 10-20 WB 1825A/ND)						1	—	—	KH1
10426	10-20 WB 1825A/ND	FRAME , stn. 186"-7, assembly (Spares condition)						1	—	C	

FUSELAGE
FUSELAGE AIR BRAKE

Ref. No.	Part No.	Description	No. off	Material Specification	Class of Store or L.M	Place No.
	10-20 WB 1295A	FRAME , stn. 192"-5, assembly (For spares use 10-20 WB 1787A/ND)	1	—	—	KH1
10390	10-20 WB 1787A/ND	FRAME , stn. 192"-5, assembly (Spares condition)	1	—	C	
	10-20 WB 1949ND	FRAME , rear section, stn. 197"-05 (For spares use 10-20 WB 2237ND)	1	L.72	—	KH1
15657	10-20 WB 2237ND	FRAME , rear section, stn. 197"-05 (Spares condition)	1	—	C	
	10-20 WB 1431	GUIDE , jack (For spares use 10-20 WB 1783ND)	1	L.72	—	KH1
13073	10-20 WB 1783ND	GUIDE , jack (Spares condition)	1	—	C	
	10-20 WB 2029A	HINGE , air brake, assembly	1	—	—	KH1
17622	10-20 WB 5039	Spares for :— BEARING (Mod. 1222)	2	—	C	KH2
	10-20 FS 9113	Attachments for 10-20 WB 5039, Bearing :— Block, spacer, Port	1	L.64	LM	KH2
28M/14555	A58/NS	Nut, 3/8" BSF, Port	1	—	C	
17621	10-20 WB 5017	Nut, 1/2" BSF, Starboard (Mod. 1222)	1	—	C	KH2
28P/9527619	SP.90/C7	Pin, split, Port (SP.9/C8)	1	—	C	
28P/19234	SP.90/E8	Pin, split, Starboard (SP.9/E10)	1	—	C	
28W/9419468	SP.13/N	Washer, Port	1	—	C	
	10-20 WB 1313	Washer, Starboard, 1"-12 o/d x 3/8"-52 i/d x 3/8" thick	1	S.1	LM	KH2
	10-20 FS 9113	BLOCK , distance	1	L.64	LM	KH2
	10-20 WB 1737ND	BRACKET , seal attachment	1	L.72	LM	
	10-20 WB 1738ND	BRACKET , seal attachment	1	L.72	LM	
	10-20 WB 1739ND	BRACKET , seal attachment	1	L.72	LM	
	10-20 WB 1740ND	BRACKET , seal attachment	1	L.72	LM	
		Attachments for 10-20 WB 1737ND, 10-20 WB 1738ND, 10-20 WB 1739ND or 10-20 WB 1740ND, Bracket (per pair) :—				
10762	DHS.365/16C	Bolt, 2 BA	1	—	C	
28M/9403520	A27/CP	Nut, 2 BA	1	—	C	
28W/9419402	SP.13/C	Washer	1	—	C	
7780	10-20 WB 1253	BUSH (See Repair Section PA)	2	—	C	KH2
17096	10-20 WB 1467	BUSH	2	—	C	KH2
17525	10-20 FS 20853A	LEVER , assembly (Mod. 1222)	1	—	P	KH2
		Spares for :—				
17526	10-20 FS 20809	SPRING	1	—	C	KH2
17619	10-20 WB 5009A	PIN , hinge, Port (Mod. 1222)	1	—	C	KH2
17620	10-20 WB 5007A	PIN , hinge, Starboard (Mod. 1222)	1	—	C	KH2
		Spares for :—				
28N/9156370	SP.21	NIPPLE , lubrication	1	—	C	KH2
		Attachments for 10-20 WB 5009A or 10-20 WB 5007A, Pin :—				
7785	10-20 WB 1319	Nut, special, 3/8" BSF	1	—	C	KH2
28W/9419505	SP.41/S	Washer	1	—	C	

FUSELAGE
FUSELAGE AIR BRAKE

Ref. No.	Part No.	Description	No. off	Material Specification	Class of Score or L.M	Plate No.
	10-20 WB 1747ND	SEAL, rubber (Make from Section J.1024, Ref. No. 26DV/9500)	1	—	LM	
	10-20 WB 1748ND	SEAL, rubber (Make from Section J.1024, Ref. No. 26DV/9500)	1	—	LM	
	10-20 WB 1745ND	STRIP, seal retaining (Make from Section J.1064, Ref. No. 26FY/9185)	1	—	LM	
	10-20 WB 1746ND	STRIP, seal retaining (Make from Section J.1064, Ref. No. 26FY/9185)	1	—	LM	
	10-20 WB 1397ND	INTERCOSTAL, at stn. 192"-5, Port (For spares use 10-20 WB 1811ND)	1	L.72	—	KH1
10403	10-20 WB 1811ND	INTERCOSTAL, at stn. 192"-5, Port (Spares condition)	1	—	C	
	10-20 WB 1398ND	INTERCOSTAL, at stn. 192"-5, Starboard (For spares use 10-20 WB 1821ND)	1	L.72	—	KH1
10404	10-20 WB 1812ND	INTERCOSTAL, at stn. 192"-5, Starboard (Spares condition)	1	—	C	
	10-20 WB 1399ND	INTERCOSTAL, at stn. 192"-5, Port (For spares use 10-20 WB 1809ND)	1	L.72	—	KH1
10401	10-20 WB 1809ND	INTERCOSTAL, at stn. 192"-5, Port (Spares condition)	1	—	C	
	10-20 WB 1400ND	INTERCOSTAL, at stn. 192"-5, Starboard (For spares use 10-20 WB 1810ND)	1	L.72	—	KH1
10402	10-20 WB 1810ND	INTERCOSTAL, at stn. 192"-5, Starboard (Spares condition)	1	—	C	
	10-20 WB 1389ND	INTERCOSTAL, between stns. 180"-9 and 186"-7, Port (For spares use 10-20 WB 1805ND)	1	L.72	—	KH1
10397	10-20 WB 1805ND	INTERCOSTAL, between stns. 180"-9 and 186"-7, Port (Spares condition)	1	—	C	
	10-20 WB 1390ND	INTERCOSTAL, between stns. 180"-9 and 186"-7, Starboard (For spares use 10-20 WB 1806ND)	1	L.72	—	KH1
10398	10-20 WB 1806ND	INTERCOSTAL, between stns. 180"-9 and 186"-7, Starboard (Spares condition)	1	—	C	
	10-20 WB 1391ND	INTERCOSTAL, between stns. 180"-9 and 186"-7, Port (For spares use 10-20 WB 1803ND)	1	L.72	—	KH1
10395	10-20 WB 1803ND	INTERCOSTAL, between stns. 180"-9 and 186"-7, Port (Spares condition)	1	—	C	
	10-20 WB 1392ND	INTERCOSTAL, between stns. 180"-9 and 186"-7, Starboard (For spares use 10-20 WB 1804ND)	1	L.72	—	KH1
10396	10-20 WB 1804ND	INTERCOSTAL, between stns. 180"-9 and 186"-7, Starboard (Spares condition)	1	—	C	

FUSELAGE

FUSELAGE AIR BRAKE

Ref. No.	Part No.	Description	No. off	Material Specification	Class of Score or L.M.	Place No.
	10-20 WB 1393A	INTERCOSTAL , between stns. 186"-7 and 192"-5, Port assembly (For spares use 10-20 WB 1771A/ND)	1	—	—	KH1
10365	10-20 WB 1771A/ND	INTERCOSTAL , between stns. 186"-7 and 192"-5, Port, assembly (Spares condition)	1	—	C	
	10-20 WB 1394A	INTERCOSTAL , between stns. 186"-7 and 192"-5, Starboard, assembly (For spares use 10-20 WB 1772A/ND)	1	—	—	KH1
10366	10-20 WB 1772A/ND	INTERCOSTAL , between stns. 186"-7 and 192"-5, Starboard (Spares condition) Attachments for 10-20 WB 1393A or 10-20 WB 1394A, Intercostal :—	1	—	C	
28D/9133011	A25/2C	Bolt, 2 BA	4	—	C	
28D/9133012	A25/3C	Bolt, 2 BA	2	—	C	
28M/9403520	A27/CP	Nut, 2 BA	6	—	C	
28W/9419475	SP.15/C	Washer	2	—	C	
7765	DHS.729/C/16	Washer	2	—	C	KH1
	10-20 WB 1395A	INTERCOSTAL , between stns. 186"-7 and 192"-5, Port, assembly (For spares use 10-20 WB 1765A/ND)	1	—	—	KH1
10369	10-20 WB 1765A/ND	INTERCOSTAL , between stns. 186"-7 and 192"-5, Port, assembly (Spares condition)	1	—	C	
	10-20 WB 1396A	INTERCOSTAL , between stns. 186"-7 and 192"-5, Starboard, assembly (For spares use 10-20 WB 1766A/ND)	1	—	—	KH1
10370	10-20 WB 1766A/ND	INTERCOSTAL , between stns. 186"-7 and 192"-5, Starboard, assembly (Spares condition)	1	—	C	
	10-20 WB 1619A	INTERCOSTAL , between stns. 180"-9 and 186"-7, Port, assembly (For spares use 10-20 WB 1777A/ND)	1	—	—	KH1
10371	10-20 WB 1777A/ND	INTERCOSTAL , between stns. 180"-9 and 186"-7 Port, assembly (Spares condition)	1	—	C	
	10-20 WB 1620A	INTERCOSTAL , between stns. 180"-9 and 186"-7, Starboard, assembly (For spares use 10-20 WB 1778A/ND)	1	—	—	KH1
13072	10-20 WB 1778A/ND	INTERCOSTAL , between stns. 180"-9 and 186"-7, Starboard, assembly (Spares condition)	1	—	C	

**FUSELAGE
FUSELAGE AIR BRAKE**

Ref. No.	Part No.	Description	No. off	Material Specification	Class of Store or L.M.	Place No.
	10-20 WB 1621A	INTERCOSTAL , between stns. 180"-9 and 186"-7, Port, assembly (For spares use 10-20 WB 1759A/ND)	1	—	—	KH1
10374	10-20 WB 1759A/ND	INTERCOSTAL , between stns. 180"-9 and 186"-7 Port, assembly (Spares condition)	1	—	C	
	10-20 WB 1622A	INTERCOSTAL , between stns. 180"-9 and 186"-7, Starboard, assembly (For spares use 10-20 WB 1760A/ND)	1	—	—	KH1
10375	10-20 WB 1760A/ND	INTERCOSTAL , between stns. 180"-9 and 186"-7, Starboard, assembly (Spares condition)	1	—	C	
		Attachments for 10-20 WB 1621A or 10-20 WB 1622A, Intercostal :—				
28D/1011030	A25/2E	Bolt, 1/2" BSF	6	—	C	
28M/12928	A27/EP	Nuc, 1/2" BSF	6	—	C	
28W/9419405	SP.15/E	Washer	6	—	C	
	10-20 WB 1255	MEMBER , edge, L.E. to stn. 197", Port (For spares use 10-20 WB 1799ND)	1	L.72	—	KH1
10377	10-20 WB 1799ND	MEMBER , edge, L.E. to stn. 197", Port (Spares condition)	1	L.72	C	
	10-20 WB 1256	MEMBER , edge, L.E. to stn. 197", Starboard (For spares use 10-20 WB 1800ND)	1	L.72	—	KH1
10378	10-20 WB 1800ND	MEMBER , edge, L.E. to stn. 197", Starboard (Spares condition)	1	L.72	C	
	10-20 WB 1445	PAD , at station 197"-05, 1"-8 x "9 x 1/8" thick	1	LFS.21	LM	KH1
		Attachments for 10-20 WB 1445, Pad :—				
28D/1013172	AS.1242/5C	Bolt, 2 BA	2	—	C	
7779	10-20 WE 1471	Shim, Attewell, 1"-8 x "9	1	LA.3	C	KH1
7796	10-20 WB 1523	PIN , fairing hinge... ..	1	S.96	C	KH2
	10-20 WB 2047ND	PLATE , cover, at stn. 163"-45, 16 SWG ...	2	L.73	LM	KH1
		Attachments for 10-20 WB 2047ND, Plate :—				
28D/9133011	A25/2C	Bolt, 2 BA	8	—	C	
28W/9419404	SP.16/C	Washer	8	—	C	
	10-20 WB 1711ND	SEAL , rubber, edge member, Port (Make from Ref. No. 26FY/6636)	1	—	LM	KH1
	10-20 WB 1712ND	SEAL , rubber, edge member, Starboard ... (Make from Ref. No. 26FY/6636)	1	—	LM	KH1

FUSELAGE

FUSELAGE AIR BRAKE

Ref. No.	Part No.	Description	No. off	Material Specification	Class of Store or L.M	Place No.
15654	10-20 WB 1863ND	SKIN , inner (For spares use 10-20 WB 2235ND)	1	L.73	—	KH1
	10-20 WB 2235ND	SKIN , inner (Spares condition)	1	L.73	C	
28D/7002428	A25/6C	Attachments for 10-20 WB 1863ND, Skin:—				
28M/10288	AGS.2001/C/1	Bolt, 2 BA	6	—	C	
28M/9403520	A27/CP	Nut, 2 BA	2	—	C	
28W/9419475	SP.15/C	Nut, 2 BA	4	—	C	
		Washer	6	—	C	
10411	10-20 WB 1405ND	SKIN , outer (For spares use 10-20 WB 1821ND)	1	L.72	—	KH1
	10-20 WB 1821ND	SKIN , outer (Spares condition)	1	L.72	C	
		Attachments for 10-20 WB 1405ND, Skin:—				
2455	DHS.365/6C	Bolt, 2 BA	6	—	C	KH1
15286	DHS.365/7C	Bolt, 2 BA	16	—	C	
7746	DHS.365/20C	Bolt, 2 BA	2	—	C	KH1
7745	DHS.365/24C	Bolt, 2 BA	2	—	C	
26DV/5897	DHS.365/4E	Bolt, 1/2" BSF	4	—	C	KH1
1793	DHS.365/5E	Bolt, 1/2" BSF	4	—	C	
1794	DHS.365/6E	Bolt, 1/2" BSF	4	—	C	KH1
3810	DHS.365/7E	Bolt, 1/2" BSF	6	—	C	
28D/10473	AS.1248/6E	Bolt, 1/2" BSF	4	—	C	KH1
28D/14748	AS.1248/7G	Bolt, 1/2" BSF	6	—	C	
28M/9403520	A27/CP	Nut, 2 BA	26	—	C	
28M/12928	A27/EP	Nut, 1/2" BSF	22	—	C	
28M/1006939	A27/GP	Nut, 3/8" BSF	6	—	C	
28W/9419475	SP.15/C	Washer	26	—	C	
28W/9419405	SP.15/E	Washer	22	—	C	
28W/9419488	SP.16/G	Washer	6	—	C	
7797	10-20 WB 1525	SPRING , at fairing hinge	8	DTD.187	C	KH2
		Attachments for 10-20 WB 1525, Spring:—				
28D/9133012	A25/3C	Bolt, 2 BA	2	—	C	
28W/9419475	SP.15/C	Washer	2	—	C	
	10-20 WB 1623A	STRAKE , forward member to station 197"-05, Port, assembly	1	—	—	KH1
	10-20 WB 1624A	STRAKE , forward member to station 197"-05, Starboard, assembly	1	—	—	
10758	10-20 WB 1671ND	Spares for:—				
10759	10-20 WB 1672ND	BRACKET , angle attachment, inboard, Port	1	DTD.683	C	KH1
		BRACKET , angle attachment, inboard, Starboard	1	DTD.683	C	
		Attachments for 10-20 WS 1671 ND or 10-20 WB 1672 ND, Bracket:—				
	10-20 WB 2231ND	Bolt (Make from Ref. No. 28D/10640, Part No. AS.1248/2E)	1	—	LM	KH
	10-20 WB 2233ND	Bolt (Make from Ref. No. 28D/9798, Part No. AS.1248/3E)	5	—	LM	
28M/12931	A27/ET	Nut, 1/2" BSF	6	—	C	
28W/9418921	SP.13/E	Washer	6	—	C	

KH.1

SEE TEXT FOR SPARES CONDITION OF ITEMS MARKED THUS :- *

BOLTS, SKIN ATTACHMENT.
DHS 365/4E
DHS 365/5E
DHS 365/6C
DHS 365/6E
DHS 365/20C
DHS 365/24C

See Detail Plate KH.2.

COUPLING, JACK ATTACHMENT.
See Detail Plate KH.2.

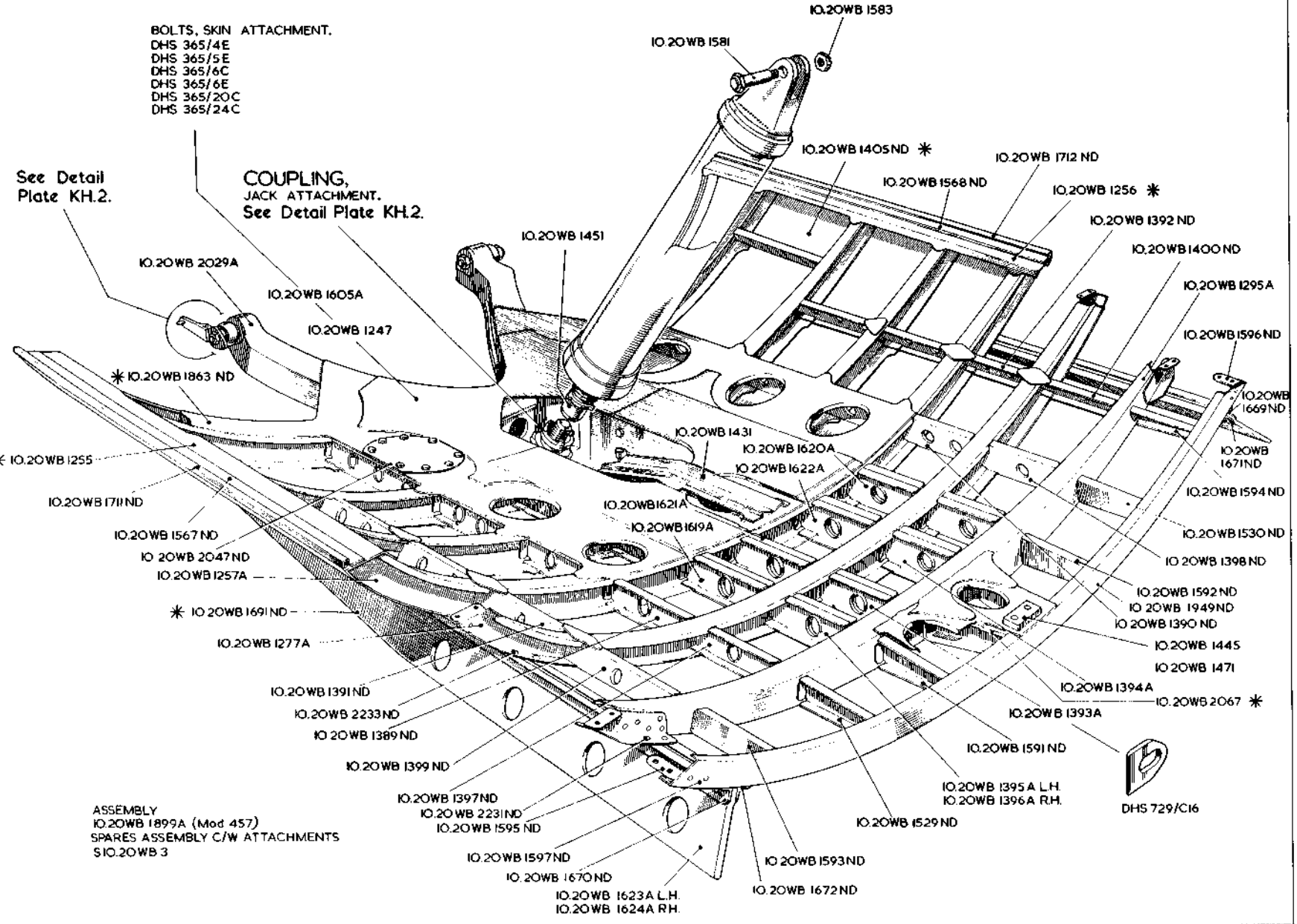

FUSELAGE
AIR BRAKE

RESTRICTED

See Vixen Mk.1

RESTRICTED

Plate KH1

KH.1
[AL.62]

SEE TEXT FOR SPARES CONDITION OF ITEMS MARKED THUS :- *

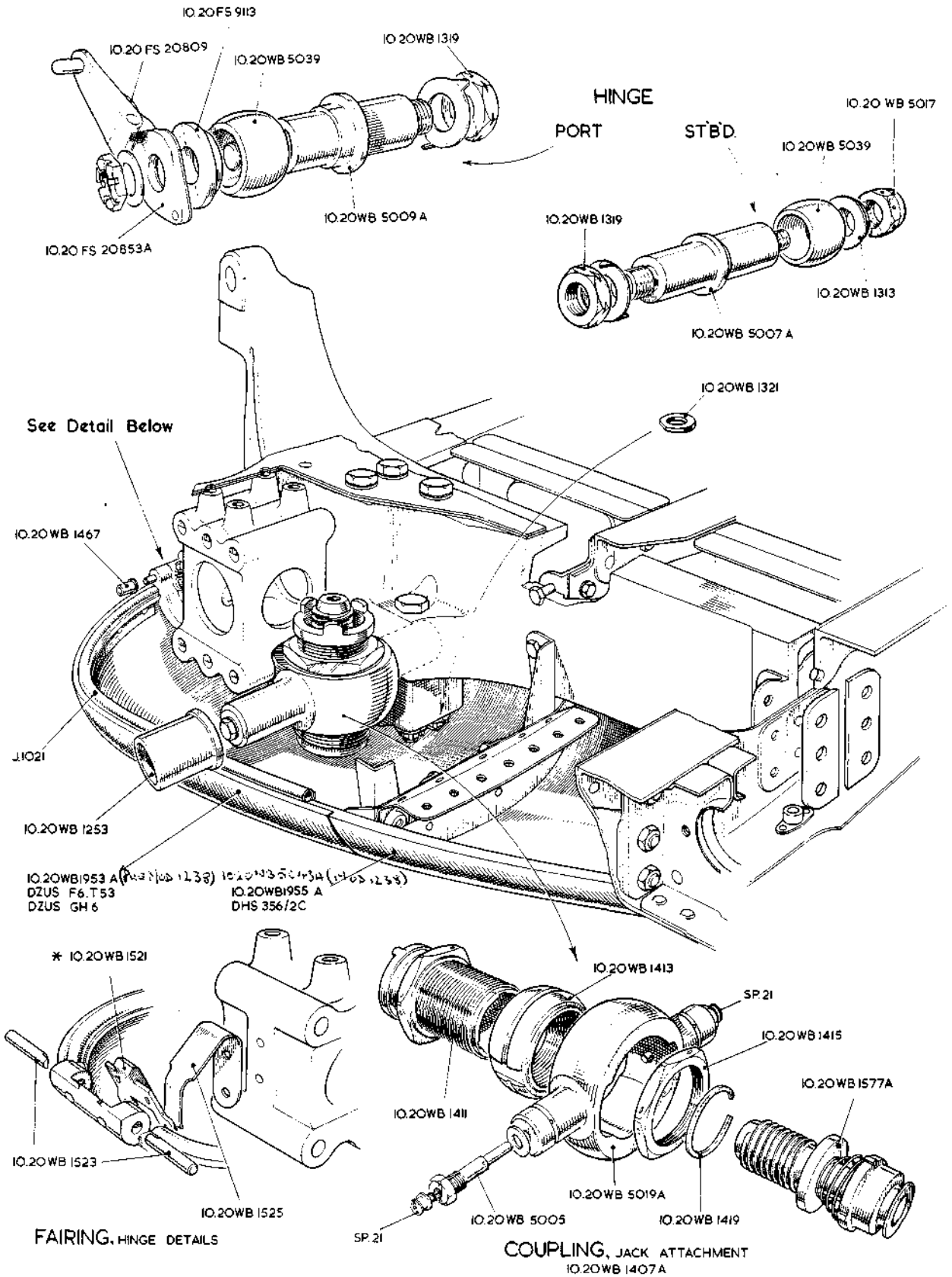

KH.2

FUSELAGE

KH.2

AIR BRAKE

[A.L. 42]

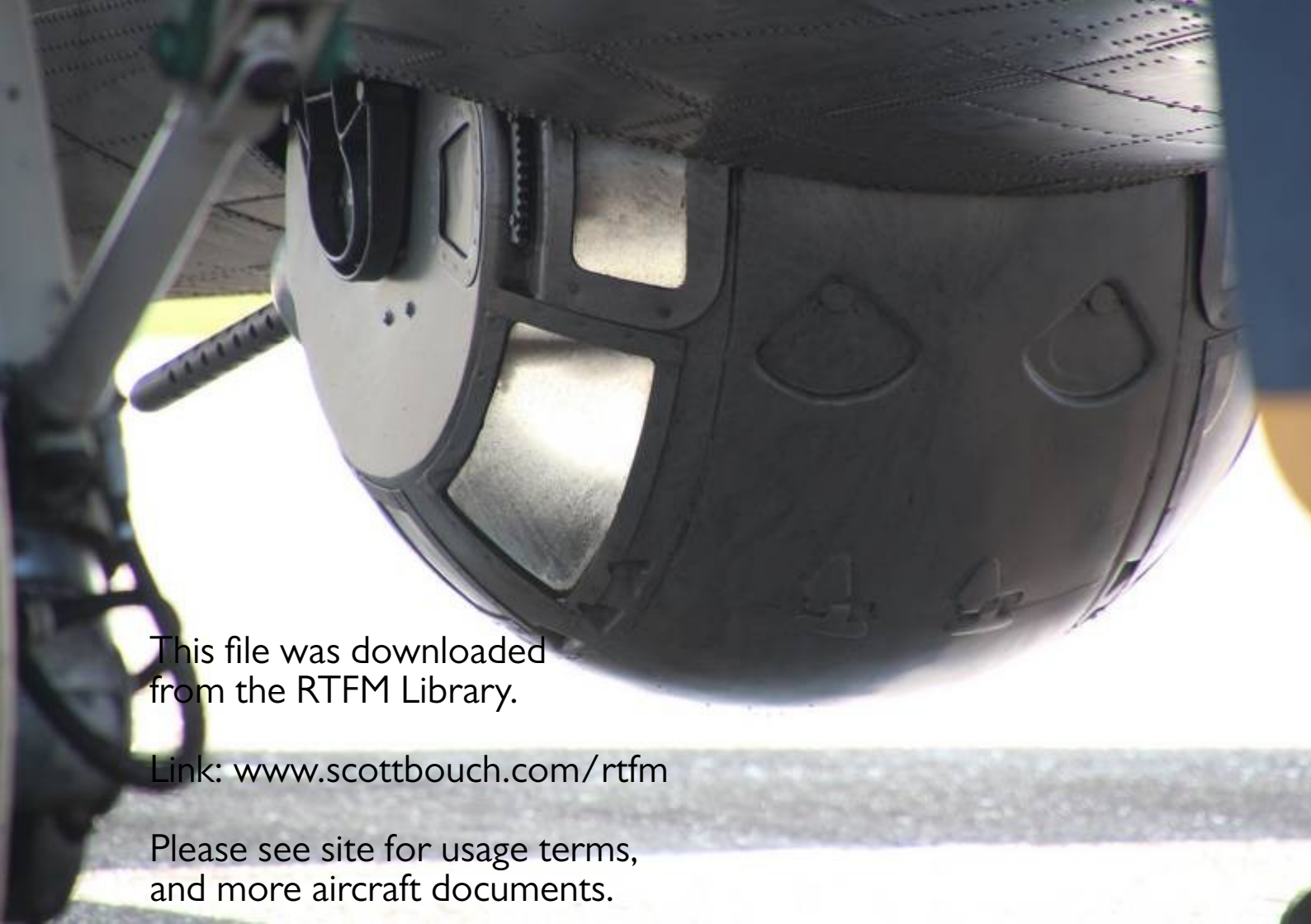

This file was downloaded
from the RTFM Library.

Link: www.scottbouch.com/rtfm

Please see site for usage terms,
and more aircraft documents.