

MAIN PLANES

BOUNDARY-LAYER AND FUSELAGE INTAKE PANELS

Ref. No.	Part No.	Description	No. off	Material Specification	Class of Store or L.M	Plate No.
	—	INSTALLATION OF BOUNDARY-LAYER AND FUSELAGE INTAKE PANELS, top and bottom (Drg. No. 10-20 WC 22897A)	1	—	—	
	10-20 WC 12261A	BOUNDARY-LAYER, air bleed nose portion, Port, assembly (For spares use 10-20 WC 31203A/ND)	1	—	—	LB1
16120	10-20 WC 31203A/ND	BOUNDARY-LAYER, air-bleed nose portion, Port, assembly (Spares condition)	1	—	P	
	10-20 WC 12262A	BOUNDARY-LAYER, air bleed nose portion, Starboard, assembly (For spares use 10-20 WC 31204A/ND)	1	—	—	LB1
16121	10-20 WC 31204A/ND	BOUNDARY-LAYER, air-bleed nose portion, Starboard, assembly (Spares condition)	1	—	P	
28M/11957	AGS.2007/C/1	NUT, 2 BA, anchor, bottom fuselage intake panel attachment	2	—	C	
	—	PANEL, nose air bleed, Port, group (Drg. No. 10-20 WC 12249)	1	—	—	LB1
	—	PANEL, nose air bleed, Starboard, group (Drg. No. 10-20 WC 12250)	1	—	—	LB1
	10-20 WC 12499A	DOOR, Port, assembly	1	—	—	LB1
	10-20 WC 12500A	DOOR, Starboard, assembly	1	—	—	LB1
28FP/997	DZUS. F.3½/T/25	FASTENER	2	—	C	LB1
28FP/1002561	DZUS GH/3½	GROMMET	2	—	C	LB1
	10-20 WC 12549ND	HINGE (Make from Ref. No. 28N/9486785) Attachments for 10-20 WC 12549ND, Hinge :—	1	—	LM	LB1
28D/8307	AS.1242/2C	Bolt, 2 BA	4	—	C	
28M/1006473	A27/CT	Nut, 2 BA	4	—	C	
28VV/9419404	SP.16/C	Washer	4	—	C	
	10-20 WC 12505ND	PACKING, 24 SWG	1	L.72	LM	LB1
	10-20 WC 12507A/ND	PANEL, assembly	1	—	LM	LB1
	10-20 WC 12503ND	EDGE, reinforcing, 12 SWG	1	L.72	LM	LB1
	10-20 WC 12501ND	PANEL, 20 SWG	1	L.72	LM	LB1
		Attachments for 10-20 WC 12499A or 10-20 WC 12500A, Door :—				
28D/8307	AS.1242/2C	Bolt, 2 BA	6	—	C	
28D/1007976	AS.1242/4C	Bolt, 2 BA	2	—	C	
28M/9403520	A27/CP	Nut, 2 BA	8	—	C	
28VV/9419404	SP.16/C	Washer	8	—	C	
	10-20 WC 12769	DUCT, air feed, Port	1	—	—	LB1
	10-20 WC 12770	DUCT, air feed, Starboard	1	—	—	LB1
	10-20 WC 23169A/ND	FRAME, forward, Port, assembly	1	—	—	LB1
	10-20 WC 23170A/ND	FRAME, forward, Starboard, assembly	1	—	—	LB1

MAIN PLANES
BOUNDARY-LAYER AND FUSELAGE INTAKE PANELS

Ref. No.	Part No.	Description	No. off	Material Specification	Class of Score or L.M.	Plate No.
	10-20 WC 12591A/ND	PLATE , nose, Port, assembly (For spares use 10-20 WC 27771A/ND)	1	—	—	LB1
12467	10-20 WC 27771A/ND	PLATE , nose, Port, assembly (Spares condition)	1	—	C	
	10-20 WC 12592A/ND	PLATE , nose, Starboard, assembly (For spares use 10-20 WC 27772A/ND)	1	—	—	LB1
12468	10-20 WC 27772A/ND	PLATE , nose, Starboard, assembly (Spares condition)	1	—	C	
		Attachments for 10-20 WC 12591A/ND or 10-20 WC 12592A/ND, Plate :—				
1141	DHS.365/1C	Bolt, 2 BA	24	—	C	LB1
28M/9403520	A27/CP	Nut, 2 BA	24	—	C	
28W/9419404	SP.16/C	Washer	24	—	C	
	10-20 WC 12541A/ND	PLATE , face, de-icing, Port, assembly	1	—	—	LB1
	10-20 WC 12542A/ND	PLATE , face, de-icing, Starboard, assembly	1	—	—	LB1
27FP/9438596	DZUS R.3½	RECEPTACLE , fastener, door	2	—	C	LB1
	10-20 WC 12255A	PIPE , air feed, Port, assembly	1	—	—	LB1
	10-20 WC 12256A	PIPE , air feed, Starboard, assembly	1	—	—	LB1
		Attachments for 10-20 WC 12255A or 10-20 WC 12256A, Pipe :—				
28D/1212941	A61/3C	Bolt, 2 BA	6	—	C	
28D/1212943	A61/5C	Bolt, 2 BA	4	—	C	
28M/13324	A29/CP	Nut, 2 BA	10	—	C	
	10-20 WC 13157	Ring, packing	1	LFS.23	LM	LB1
27QA/677	DOWTY GD.2001B/21	Ring, "O" (No. 21, Silicone)	1	—	C	LB1
28W/9419404	SP.16/C	Washer	10	—	C	
	10-20 WC 13183	SPIGOT	4	—	—	LB1
		Attachments for 10-20 WC 13183, Spigot :—				
28M/13717	A29/GP	Nut, ⅜" BSF	1	—	C	
28W/9419488	SP.16/G	Washer	1	—	C	
6600	J.2200	STRIP , rubber sealing	QR	—	C	LB1
		Attachments for J.2200, Strip :—				
	10-20 WC 14569ND	Angle, Port (For spares use 10-20 WC 28663ND)	1	—	—	LB1
13709	10-20 WC 28663ND	Angle, Port (Spares condition)	1	—	C	
	10-20 WC 14570ND	Angle, Starboard (For spares use 10-20 WC 28664ND)	1	—	—	LB1
13710	10-20 WC 28664ND	Angle, Starboard (Spares condition)	1	—	C	
6389	DHS.365/1½C	Bolt, 2 BA	33	—	C	LB1
1092	DHS.365/2C	Bolt, 2 BA	6	—	C	LB1
28M/9403520	A27/CP	Nut, 2 BA	6	—	C	
28M/13324	A29/CP	Nut, 2 BA	33	—	C	
28W/9419404	SP.16/C	Washer	39	—	C	
		Attachments for 10-20 WC 12261A or 10-20 WC 12262A, Boundary-Layer :—				
28D/9709461	AS.1242/3C	Bolt, 2 BA	5	—	C	
5615	A25/6E/DHS.514/D	Bolt, ¼" BSF	2	—	C	
8536	10-20 WC 12227	Bolt, ⅜" BSF	2	—	C	LB1
28W/9418920	SP.10/E	Washer	2	—	C	

MAIN PLANES
BOUNDARY-LAYER AND FUSELAGE INTAKE PANELS

Ref. No.	Part No.	Description	No. off	Material Specification	Class of Store or L.M	Place No.
	—	BRACKET , support, air intake, lower, group ...	2	—	—	
	—	BRACKET , support, air intake upper, group ...	2	—	—	
28D/1200119	A25/4C	BOLT , 2 BA ...	4	—	C	
28D/1008151	A25/4E	BOLT , 1/4" BSF ...	2	—	C	
6556	10-20 WC 7605	BRACKET , support, lower ...	1	—	C	LB1
6555	10-20 WC 12461	BRACKET , support, upper ...	1	—	C	LB1
6558	10-20 WC 12225	SHIM (lower bracket) ...	1	—	C	LB1
6557	10-20 WC 13215	SHIM (upper bracket) ...	1	—	C	LB1
	10-20 WC 12263	SHIM , between bracket and leading edge members, 0"-8 x 0"-8	1	LA.3	—	LB1
28W/9419402	SP.13/C	WASHER ...	QR	—	C	
28W/9418921	SP.13/E	WASHER ...	QR	—	C	
	10-20 WC 12001A	PANEL , fuselage, intake bottom, Port, assembly (For spares use 10-20 WC 26985A/ND)	1	—	—	LB1
11372	10-20 WC 26985A/ND	PANEL , fuselage intake, bottom, Port, assembly (Spares condition)	1	—	P	
	10-20 WC 12002A	PANEL , fuselage intake, bottom, Starboard, assembly (For spares use 10-20 WC 26986A/ND)	1	—	—	LB1
11373	10-20 WC 26986A/ND	PANEL , fuselage intake, bottom, Starboard, assembly (Spares condition)	1	—	P	
	10-20 WC 12009/ND	DOUBLER , Port, 14 SWG ...	1	L.73	—	LB1
	10-20 WC 12010ND	DOUBLER , Starboard, 14 SWG ...	1	L.73	LM	LB1
	10-20 WC 12011ND	FAIRLEAD , Port, 1/2" thick ...	1	LFS.23	LM	LB1
	10-20 WC 12012ND	FAIRLEAD , Starboard, 1/2" thick ...	1	LFS.23	LM	LB1
	10-20 WC 12016ND	SEAL , rubber, aft (Make from standard section J.2200, Ref. No. 26FY/6600)	1	—	LM	LB1
	10-20 WC 12015ND	SEAL , rubber, forward (Make from standard section J.2200, Ref. No. 26FY/6600)	1	—	LM	LB1
	10-20 WC 12021ND	STRIP , retaining, aft, 20 SWG ...	1	L.73	LM	LB1
	10-20 WC 12019ND	STRIP , retaining, forward, 20 SWG ...	1	L.73	LM	LB1
		Attachments for 10-20 WC 12001A or 10-20 WC 12002A, Panel :—				
28D/8307	AS.1242/2C	Bolt, 2 BA ...	10	—	C	
28D/9709461	AS.1242/3C	Bolt, 2 BA ...	8	—	C	
28D/1204937	AS.1242/6C	Bolt, 2 BA ...	1	—	C	
28D/1013177	AS.1242/2E	Bolt, 1/2" BSF ...	1	—	C	
28D/8325	AS.1242/4E	Bolt, 1/2" BSF ...	2	—	C	
28D/1013178	AS.1242/5E	Bolt, 1/2" BSF ...	1	—	C	
	10-20 WC 11909A	PANEL , fuselage intake, top, Port (For spares use 10-20 WC 30563A/ND)	1	—	—	LB1
16719	10-20 WC 30563A/ND	PANEL , fuselage intake, top, Port (Spares condition)	1	—	P	
	10-20 WC 11910A	PANEL , fuselage intake, top, Starboard (For spares use 10-20 WC 30564A/ND)	1	—	—	
16720	10-20 WC 30564A/ND	PANEL , fuselage intake, top, Starboard (Spares condition)	1	—	P	
	10-20 WC 24861ND	SEAL , rubber, Port (Make from standard section J.2200, Ref. No. 26FY/6600)	1	—	LM	LB1
	10-20 WC 24862ND	SEAL , rubber, Starboard (Make from standard section J.2200, Ref. No. 26FY/6600)	1	—	LM	LB1
	10-20 WC 11919ND	STRIP , retaining, Port, 20 SWG ...	1	L.73	LM	LB1
	10-20 WC 11920ND	STRIP , retaining, Starboard, 20 SWG ...	1	L.73	LM	LB1
		Attachments for 10-20 WC 11909A or 10-20 WC 11910A, Panel :—				
28D/8307	AS.1242/2C	Bolt, 2 BA ...	6	—	C	
28D/9709461	AS.1242/3C	Bolt, 2 BA ...	19	—	C	
28M/10288	AGS.2001/C/1	Nut, 2 BA ...	6	—	C	

MAIN PLANES
BOUNDARY-LAYER AND FUSELAGE INTAKE PANELS

Ref. No.	Part No.	Description						No. off	Material Specification	Class of Score or L.M.	Plate No.
		1	2	3	4	5	6				

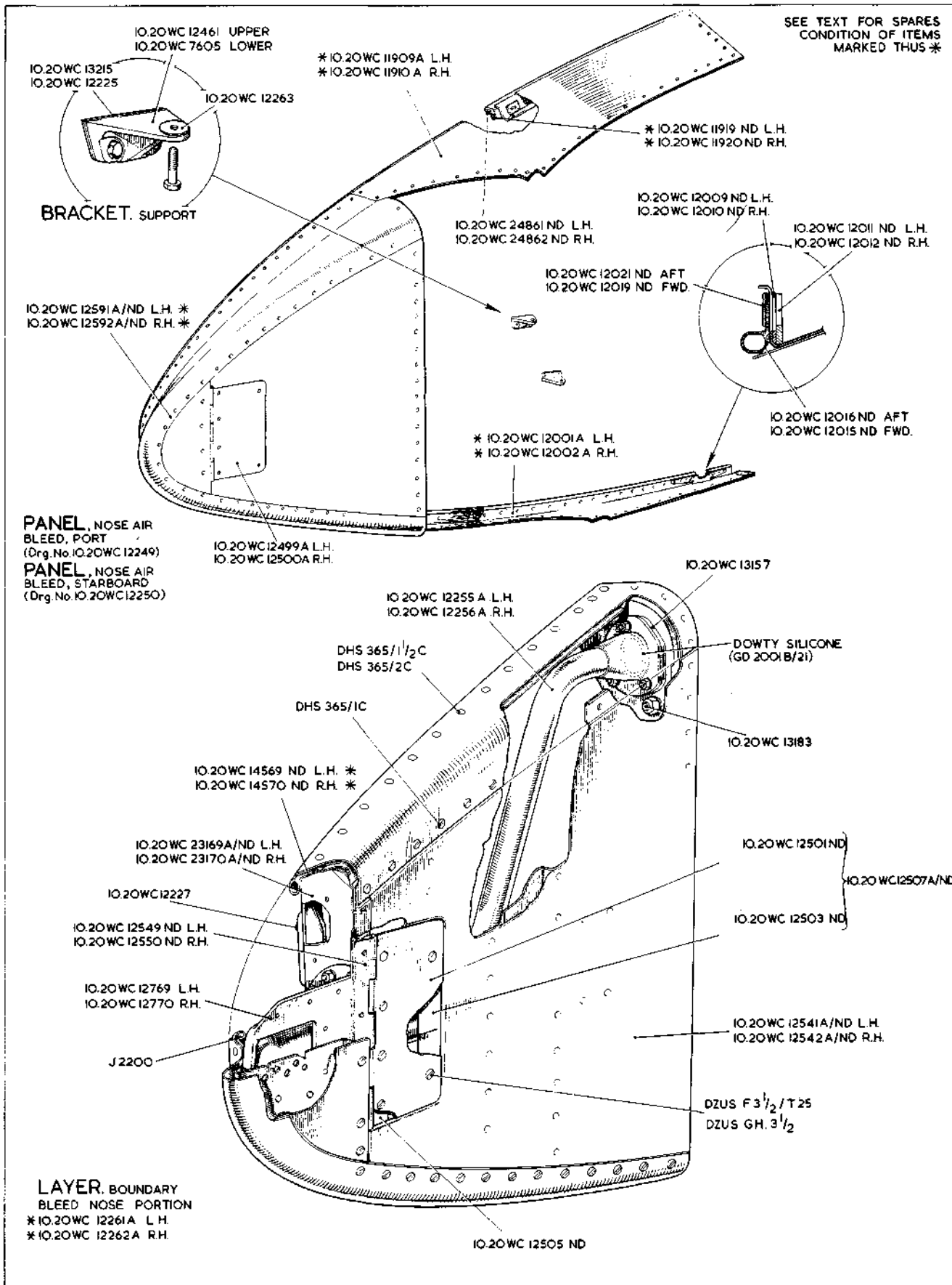

LB.J

**MAIN PLANE
BOUNDARY LAYER AND
FUSELAGE INTAKE PANELS**

LB.I
[A.L. 66]

This file was downloaded
from the RTFM Library.

Link: www.scottbouch.com/rtfm

Please see site for usage terms,
and more aircraft documents.

