

**MAIN PLANES
FLAPS, OUTER**

Ref. No.	Part No.	Description	No. off	Material Specification	Class of Store or L.M.	Place No.
73	S10-20 WF 5	FLAP , outer, Port. (special spares assembly, complete with attachments)	1	—	P	LE1
74	S10-20 WF 6	FLAP , outer, Starboard, (special spares assembly, complete with attachments)	1	—	P	LE1
	10-20 WF 955A/2	FLAP , outer, Port, assembly (Mod. 539) ...	1	—	—	LE1
	10-20 WF 956A/2	FLAP , outer, Starboard, assembly (Mod. 539) ...	1	—	—	LE1
	10-20 WF 127	BLOCK , trailing edge, at rib No. 14, Port ...	1	LFS.21	LM	LE3
	10-20 WF 128	BLOCK , trailing edge, at rib No. 14, Starboard ...	1	LFS.21	LM	LE3
	10-20 WF 129	BLOCK , trailing edge, at rib No. 16, Port ...	1	LFS.21	LM	LE3
	10-20 WF 130	BLOCK , trailing edge, at rib No. 16, Starboard ...	1	LFS.21	LM	LE3
	10-20 WF 131	BLOCK , trailing edge, at rib No. 18, Port ...	1	LFS.21	LM	LE3
	10-20 WF 132	BLOCK , trailing edge, at rib No. 18, Starboard ...	1	LFS.21	LM	LE3
	10-20 WF 133	BLOCK , trailing edge, at rib No. 20, Port ...	1	LFS.21	LM	LE3
	10-20 WF 134	BLOCK , trailing edge, at rib No. 20, Starboard ...	1	LFS.21	LM	LE3
	—	BRACKET AND ROLLER (Nos. 4 and 5), group	2	—	—	—
	10-20 WF 451A	BRACKET , roller, assembly ...	1	—	—	LE2
6865	10-20 WF 449ND	BRACKET ...	1	—	C	LE2
6866	10 WC 8849	ROLLER ...	1	—	C	LE2
		Attachments for 10 WC 8849, Roller :—				
28D/1013173	AS.1242/10C	Bolt, 2 BA ...	1	—	C	
28M/1006473	A27/CT	Nut, 2 BA ...	1	—	C	
28P/9429528	SP.9/C8	Pin, split ...	1	—	C	
6867	10-20 WF 455	Tube, distance ...	1	—	C	LE2
		Attachments for 10-20 WF 451A, Bracket :—				
26FN/3002	A25/5E/DHS.514/D	Bolt, 1/4" BSF ...	2	—	C	LE2
28D/9419397	A25/12C	Bolt, 2 BA ...	2	—	C	
28M/1006473	A27/CT	Nut, 2 BA ...	2	—	C	
	10-20 WF 459A	Pad, serrated, assembly ...	1	—	—	LE2
28W/9419404	SP.16/C	Washer ...	2	—	C	
28W/9419405	SP.15.E	Washer ...	2	—	C	
	10-20 WF 453	COVER , 16 SWG ...	1	L.73	LM	LE2
		Attachments for 10-20 WF 453, Cover :—				
20091	DHS.825.1 1/2 C	Bolt, 2 BA ...	6	—	C	LE2
26DL/15397	DHS.848/C/1	NUT , 2 BA, anchor ...	6	—	C	LE2
	10-20 WF 355A	CHANNEL , rear, Port, assembly ...	1	—	—	LE3
		(For spares use 10-20 WF 1187A/ND)				
11164	10-20 WE 1187A/ND	CHANNEL , rear, Port, assembly (Spares condition)	1	—	C	
	10-20 WF 356A	CHANNEL , rear, Starboard, assembly ...	1	—	—	LE3
		(For spares use 10-20 WF 1188A/ND)				
11165	10-20 WF 1188A/ND	CHANNEL , rear, Starboard, assembly ...	1	—	C	
		(Spares condition)				
		Spares for :—				
28M/9435067	AGS.2008/C/1	NUT , 2 BA, anchor ...	2	—	C	
	10-20 WF 219	DIAPHRAGM , between ribs Nos. 15 and 16, Port	1	L.73	—	LE1
	10-20 WF 220	DIAPHRAGM , between ribs Nos. 15 and 16, Starboard	1	L.73	—	LE1
	10-20 WF 221	DIAPHRAGM , between ribs Nos. 20 and 21, Port	1	L.73	—	LE1
	10-20 WF 222	DIAPHRAGM , between ribs Nos. 20 and 21, Starboard	1	L.73	—	LE1
	10-20 WF 997	DIAPHRAGM , nose, Port ...	1	L.73	—	LE1
	10-20 WF 998	DIAPHRAGM , nose, Starboard ...	1	L.73	—	LE1
	10-20 WF 135ND	MEMBER , trailing edge ...	1	—	—	LE3
		(For spares use 10-20 WF 1209ND)				
11230	10-20 WF 1209ND	MEMBER , trailing edge (Spares condition) ...	1	—	C	

MAIN PLANES

FLAPS, OUTER

Ref. No.	Part No.	Description	No. off	Material Specification	Class of Store or L.M.	Place No.
	10-20 WF 357	MEMBER , trailing edge locking, Port (For spares use 10-20(WF 1259ND))	1	—	—	LE3
13779	10-20 WF 1259ND	MEMBER , trailing edge locking, Port (Spares condition)	1	—	C	
	10-20 WF 358	MEMBER , trailing edge locking, Starboard (Spares For use 10-20 WF 1260ND)	1	—	—	LE3
13780	10-20 WF 1260ND	MEMBER , trailing edge locking, Starboard (Spares condition)	1	—	C	
	Attachments for 10-20 WF 357 or 10-20 WF 358, Member :—					
3815	DHS.358/4½C	Bolt, 2 BA	4	—	C	
2339	DHS.358/5C	Bolt, 2 BA	3	—	C	
7401	DHS.358/5½C	Bolt, 2 BA	3	—	C	
28M/10328	AGS.2002/C/1	Nut, 2 BA	10	—	C	
	—	RIB , No. 12, group (Drg. No. 10-20 WF 1365) (Mod. 539)	1	—	—	
	10-20 WF 1389ND	ANGLE , edge, top, Port (For spares use 10-20 WF 1475ND)	1	—	—	LE2
15645	10-20 WF 1475ND	ANGLE , edge, top, Port (Spares condition)	1	—	C	
	10-20 WF 1390ND	ANGLE , edge, top, Starboard (For spares use 10-20 WF 1476ND)	1	—	—	LE2
15646	10-20 WF 1476ND	ANGLE , edge, top, Starboard (Spares condition)	1	—	C	
	10-20 WF 559A	BRACKET , attachment arm, on forward end of rib No. 12, Port, assembly (Mod. 40) (For spares use 10-20 WF 1203A/ND)	1	—	—	LE2
11222	10-20 WF 1203A/ND	BRACKET , attachment arm, on forward end of rib No. 12, Port, assembly (Spares condition)	1	—	P	
	10-20 WF 560A	BRACKET , attachment arm, on forward end of rib No. 12, Starboard, assembly (Mod. 40) (For spares use 10-20 WF 1204A/ND)	1	—	—	LE2
11223	10-20 WF 1204A/ND	BRACKET , attachment arm, on forward end of rib No. 12, Starboard, assembly (Spares condition)	1	—	P	
	Spares for :—					
7364	10-20 WF 233	BUSH , threaded	1	—	C	LE2
28M/9993192	AGS.2009/C/1	NUT , anchor, 2 BA	3	—	C	
	10-20 WF 999ND	PACKING , under lower anchor, nut	1	L.72	—	LE2
	10-20 WF 1001ND	PACKING , under upper anchor nut	1	L.72	—	LE2
	Attachments for 10-20 WF 559A or 10-20 WF 560A, Bracket :—					
28D/9133011	A25/2C	Bolt, 2 BA	2	—	C	
1092	DHS.365/2C	Bolt, 2 BA	3	—	C	LE2
4371	DHS.365/2½C	Bolt, 2 BA	3	—	C	LE2
28D/8307	AS.1242/2C	Bolt, 2 BA	1	—	C	
28D/1013172	AS.1242/5C	Bolt, 2 BA	1	—	C	
28M/1010997	A24/CT	Nut, 2 BA	8	—	C	
28W/9419402	SP.13/C	Washer	8	—	C	

MAIN PLANES
FLAPS, OUTER

Ref. No.	Part No.	Description	No. off	Material Specification	Class of Store or L.M	Plate No.
	10-20 WF 427	DIAPHRAGM, between ribs Nos. 12 and 13, aft, Port, assembly	1	L.73	—	LE1
	10-20 WF 428	DIAPHRAGM, between ribs Nos. 12 and 13, aft, Starboard, assembly	1	L.73	—	LE1
	10-20 WF 425	DIAPHRAGM, between ribs Nos. 12 and 13, forward, Port	1	L.73	—	LE1
	10-20 WF 426	DIAPHRAGM, between ribs Nos. 12 and 13, forward, Starboard	1	L.73	—	LE1
	10-20 WF 423	DIAPHRAGM, between rib No. 12 and nose rib No. 12, Port	1	L.73	—	LE1
	10-20 WF 424	DIAPHRAGM, between rib No. 12 and nose rib No. 12, Starboard	1	L.73	—	LE1
	10-20 WF 1555A	FAIRING, rib, Port, assembly (Mod. 1027)... (For spares use 10-20 WF 1593A/ND)	1	—	—	LE2
16715	10-20 WF 1593A/ND	FAIRING, rib, Port, assembly ... (Spares condition)	1	—	C	
	10-20 WF 1556A	FAIRING, rib, Starboard, assembly ... (Mod. 1027) (For Spares use 10-20 WF 1594A/ND)	1	—	—	LE2
16716	10-20 WF 1594A/ND	FAIRING, rib, Starboard, assembly ... (Spares condition)	1	—	C	
17714	10-20 WF 1603	FITTING, interlock, trailing edge, between ribs Nos. 12 and 13, Port (Mod. 1027)	1	DHA.380	C	LE2
17715	10-20 WF 1604	FITTING, interlock, trailing edge, between ribs Nos. 12 and 13, Starboard (Mod. 1027)	1	DHA.380	C	LE2
		Attachments for 10-20 WF 1603 or 10-20 WF 1604, Fitting :—				
1007975	AS.1242/1C	Bolt, 2 BA ...	2	—	C	
28D/0300	DHS.358/2C	Bolt, 2 BA ...	2	S.96	C	LE2
1654	AGS.2002/C/1	Nut, 2 BA ...	2	—	C	
28M/10328						
	10-20 WF 433	MEMBER, trailing edge, between ribs Nos. 12 and 13, Port	1	DTD.5020	—	LE2
	10-20 WF 434	MEMBER, trailing edge, between ribs Nos. 12 and 13, Starboard	1	DTD.5020	—	LE2
4993192	AGS.2009/C/1	NUT, anchor, 2 BA, faired block attachment, on forward portion of rib No. 12	1	—	C	
28M/10329						
17716	10-20 WF 1601ND	PACKING, tapered, between interlock fitting and plate (Mod. 1027)	1	L.72	C	
	10-20 WF 367	PAD, angled, faired block attachment, at forward portion of rib No. 12	1	L.72	LM	LE2

MAIN PLANES
FLAPS, OUTER

Ref. No.	Part No.	Description	No. off	Material Specification	Class of Score or L.M	Plate No.
10305	10-20 WF 1067	PLATE, interlocking, Port	1	S.96	C	LE2
10306	10-20 WF 1068	PLATE, interlocking, Starboard	1	S.96	C	LE2
		Attachments for 10-20 WF 1067 or 10-20 WF 1068, Plate :—				
28D/10472	AS.1248/12C	Bolt, 2 BA	1	—	C	LE2
8473	DHS.358/13C	Bolt, 2 BA	1	—	C	LE2
1655	DHS.358/3C	Bolt, 2 BA	1	—	C	LE2
2339	DHS.358/5C	Bolt, 2 BA	1	—	C	LE2
1788	DHS.358/6C	Bolt, 2 BA	1	—	C	LE2
10307	10-20 WF 1109ND	Washer, tapered	1	S.96	C	LE2
7360	10-20 WF 435	PLATE, serrated, on forward portion of rib No. 12, Port	1	S.96	C	LE2
7361	10-20 WF 436	PLATE, serrated, on forward portion of rib No. 12, Starboard	1	S.96	C	LE2
		Attachments for 10-20 WF 435 or 10-20 WF 436, Plate :—				
28D/8307	AS.1242/2C	Bolt, 2 BA	2	—	C	
28M/10328	AGS.2002/C/1	Nut, 2 BA	2	—	C	
1790	DHS.726/C/16	Washer, support	2	DTD.746	C	LE2
	10-20 WF 1557A	RIB, No. 12, Port, assembly (Mod. 1027) (For spares use 10-20 WF 1597A/ND)	1	—	—	LE1
16717	10-20 WF 1597A/ND	RIB, No. 12, Port, assembly (Spares condition)	1	—	C	
	10-20 WF 1558A	RIB, No. 12, Starboard, assembly (Mod. 1027) (For spares use 10-20 WF 1598A/ND)	1	—	—	LE1
16718	10-20 WF 1598A/ND	RIB, No. 12, Starboard, assembly (Spares condition)	1	—	C	
		Attachments for 10-20 WF 1557A or 10-20 WF 1558A, Rib :—				
433011 28D/12513	A25/2C	Bolt, 2 BA	3	—	C	

**MAIN PLANES
FLAPS, OUTER**

Ref. No.	Part No	Description	No. off	Material Specification	Class of Store or L.M.	Plate No.
	10-20 WF 305A/1	RIB, No. 13, Port, assembly ... (for spares use 10-20 WF 1175A/ND)	1	—	—	LE1
11206	10-20 WF 1175A/ND	RIB, No. 13, Port, assembly (spare condition ...	1	—	C	
	10-20 WF 306A/1	RIB, No. 13, Starboard, assembly ... (for spares use 10-20 WF 1176A/ND)	1	—	—	LE1
11207	10-20 WF 1176A/ND	RIB, No. 13, Starboard, assembly (spares condition)	1	—	C	
	10-20 WF 157A	RIB, No. 14, Port, assembly ... (for spares use 10-20 WF 1121A/ND)	1	—	—	LE1
11142	10-20 WF 1121A/ND	RIB, No. 14, Port, assembly (spares condition) ...	1	—	C	
	10-20 WF 158A	RIB, No. 14, Starboard, assembly ... (for spares use 10-20 WF 1122A/ND)	1	—	—	LE1
11143	10-20 WF 1122A/ND	RIB, No. 14, Starboard, assembly (spares condition)	1	—	C	
	10-20 WF 163A	RIB, No. 15, Port, assembly ... (for spares use 10-20 WF 1127A/ND)	1	—	—	LE1
11144	10-20 WF 1127A/ND	RIB, No. 15, Port, assembly (spares condition) ...	1	—	C	
	10-20 WF 164A	RIB, No. 15, Starboard, assembly ... (for spares use 10-20 WF 1128A/ND)	1	—	—	LE1
11145	10-20 WF 1128A/ND	RIB, No. 15, Starboard, assembly (spares condition)	1	—	C	
	10-20 WF 271A	RIB, No. 16, Port, assembly ... (for spares use 10-20 WF 1199A/ND)	7	—	—	LE1
11262	10-20 WF 1199A/ND	RIB, No. 16, Port, assembly (spares condition) ...	1	—	C	
	10-20 WF 272A	RIB, No. 16, Starboard, assembly ... (for spares use 10-20 WF 1200A/ND)	1	—	—	LE1
11263	10-20 WF 1200A/ND	RIB, No. 16, Starboard, assembly (spares condition)	1	—	C	
	10-20 WF 223	RIB, No. 16A, Port ... (for spares use 10-20 WF 1153A/ND)	1	L.73	—	LE1
11154	10-20 WF 1153A/ND	RIB, No. 16A, Port (spares condition) ...	1	L.73	C	
	10-20 WF 224	RIB, No. 16A, Starboard ... (for spares use 10-20 WF 1154A/ND)	1	L.73	—	LE1
11155	10-20 WF 1154A/ND	RIB, No. 16A, Starboard (spares condition) ...	1	L.73	C	
	10-20 WF 169A	RIB, No. 17, Port, assembly ... (for spares use 10-20 WF 1133A/ND)	1	—	—	LE1
11146	10-20 WF 1133A/ND	RIB, No. 17, Port, assembly (spares condition) ...	1	—	C	
	10-20 WF 170A	RIB, No. 17, Starboard, assembly ... (for spares use 10-20 WF 1134A/ND)	1	—	—	LE1
11147	10-20 WF 1134A/ND	RIB, No. 17, Starboard, assembly (spares condition)	1	—	C	
	10-20 WF 175A	RIB, No. 18, Port, assembly ... (for spares use 10-20 WF 1139A/ND)	1	—	—	LE1
11148	10-20 WF 1139A/ND	RIB, No. 18, Port, assembly (spares condition) ...	1	—	C	

**MAIN PLANES
FLAPS, OUTER**

Ref. No.	Part No.	Description	No. off	Material Specification	Class of Store or L.M.	Plate No.
	10-20 WF 176A	RIB, No. 18, Starboard, assembly ... (for spares use 10-20 WF 1140A/ND)	1	—	—	LE1
11149	10-20 WF 1140A/ND	RIB, No. 18, Starboard, assembly (spares condition)	1	—	C	
	10-20 WF 181A	RIB, No. 19, Port, assembly ... (for spares use 10-20 WF 1143A/ND)	1	—	—	LE1
11150	10-20 WF 1143A/ND	RIB, No. 19, Port, assembly (spares condition) ...	1	—	C	
	10-20 WF 182A	RIB, No. 19, Starboard, assembly ... (for spares use 10-20 WF 1144A/ND)	1	—	—	LE1
11151	10-20 WF 1144A/ND	RIB, No. 19, Starboard, assembly (spares condition)	1	—	C	
	10-20 WF 187A	RIB, No. 20, Port, assembly ... (for spares use 10-20 WF 1149A/ND)	1	—	—	LE1
11152	10-20 WF 1149A/ND	RIB, No. 20, Port, assembly (spares assembly) ...	1	—	C	
	10-20 WF 188A	RIB, No. 20, Starboard, assembly ... (for spares use 10-20 WF 1150A/ND)	1	—	—	LE1
11153	10-20 WF 1150A/ND	RIB, No. 20, Starboard, assembly (spares condition)	1	—	C	
	10-20 WF 275A	RIB, No. 21, Port, assembly ... (for spares use 10-20 WF 1157A/ND)	1	—	—	LE1
11158	10-20 WF 1157A/ND	RIB, No. 21, Port, assembly ... (spares condition)	1	—	C	
	10-20 WF 276A	RIB, No. 21, Starboard, assembly ... (for spares use 10-20 WF 1158A/ND)	1	—	—	LE1
11159	10-20 WF 1158A/ND	RIB, No. 21, Starboard, assembly (spares condition)	1	—	C	
	10-20 WF 225	RIB, No. 21A, Port ... (for spares use 10-20 WF 1155ND)	1	L.73	—	LE1
11156	10-20 WF 1155ND	RIB, No. 21A, Port (spares condition) ...	1	L.73	C	
	10-20 WF 226	RIB, No. 21A, Starboard ... (for spares use 10-20 WF 1156ND)	1	L.73	—	LE1
11157	10-20 WF 1156ND	RIB, No. 21A, Starboard (spares condition) ...	1	L.73	C	
	10-20 WF 345A	RIB, No. 22, Port, assembly ... (for spares use 10-20 WF 1181A/ND)	1	—	—	LE1
11162	10-20 WF 1181A/ND	RIB, No. 22, Port, assembly (spares condition) ...	1	—	C	
	10-20 WF 346A	RIB, No. 22, Starboard, assembly ... (for spares use 10-20 WF 1182A/ND)	1	—	—	LE1
11163	10-20 WF 1182A/ND	RIB, No. 22, Starboard, assembly (spares condition)	1	—	C	

**MAIN PLANES
FLAPS, OUTER**

Ref. No.	Part No.	Description	No. off	Material Specification	Class of Store or L.M	Plate No.
	—	RIB , No. 23, group (Drg. No. 10-20 WF 461) ...	1	—	—	
	10-20 WF 319	BLOCK , nose rib, No. 22 ...	1	L.64	—	LE3
	10-20 WF 495	BLOCK , trailing edge, at rib No. 23, Port	1	LFS.21	LM	LE3
	10-20 WF 496	BLOCK , trailing edge, at rib No. 23, Starboard	1	LFS.21	LM	LE3
	10-20 WF 493	BRACKET , skin support aft, Port, 20 SWG	1	L.73	LM	LE3
	10-20 WF 494	BRACKET , skin support, aft, Starboard 20 SWG	1	L.73	LM	LE3
	10-20 WF 491	BRACKET , skin support, forward, Port, 20 SWG	1	L.73	LM	LE3
	10-20 WF 492	BRACKET , skin support, forward, Starboard, 20 SWG	1	L.73	LM	LE3
	10-20 WF 227	DIAPHRAGM , between ribs Nos. 22 and 23, aft, Port	1	L.73	—	LE1
	10-20 WF 228	DIAPHRAGM , between ribs Nos. 22 and 23, aft, Starboard	1	L.73	—	LE1
	10-20 WF 231	DIAPHRAGM , between ribs Nos. 22 and 23, forward, Port	1	L.73	—	LE1
	10-20 WF 232	DIAPHRAGM , between ribs Nos. 22 and 23, forward, Starboard	1	L.73	—	LE1
	10-20 WF 101A	HOUSING , rotating link, at rib No. 23 and nose rib No. 22, Port, assembly (For spares use 10-20 WF 1213A/ND)	1	—	—	LE3
12122	10-20 WF 1213A/ND	HOUSING , rotating link, at rib No. 23 and nose rib No. 22, Port, assembly (Spares condition)	1	—	C	
	10-20 WF 102A	HOUSING , rotating link, at rib No. 23 and nose rib No. 22, Starboard, assembly (For spares use 10-20 WF 1214A/ND)	1	—	—	LE3
12123	10-20 WF 1214A/ND	HOUSING , rotating link, at rib No. 23 and nose rib No. 22, Starboard, assembly (Spares condition)	1	—	C	
6863	10-20 WF 497	BUSH , tapped ...	1	—	C	LE3
7371	10-20 WF 103	BUSH , tapped ...	1	—	C	LE3
		Attachments for 10-20 WF 103, Bush :—				
28D/9133011	A25/2C	Bolt, 2 BA ...	2	—	C	
28M/9403520	A27/CP	Nut, 2 BA ...	2	—	C	
		Attachments for 10-20 WF 101A or 10-20 WF 102A, Housing :—				
28D/9133011	A25/2C	Bolt, 2 BA ...	6	—	C	
28D/9140648	A25/19C	Bolt, 2 BA ...	2	—	C	
28D/1007976	AS.1242/4C	Bolt, 2 BA ...	1	—	C	
28D/1013172	AS.1242/5C	Bolt, 2 BA ...	1	—	C	
1092	DHS.365/2C	Bolt, 2 BA ...	7	—	C	LE3
28M/10328	AGS.2002/C/1	Nut, 2 BA ...	3	—	C	
28M/1006473	A27/CT	Nut, 2 BA ...	14	—	C	
26FN/3285	DHS.180 Mk. 3/X	Tag, locking ...	1	—	C	LE3
28W/9419475	SP.15/C	Washer ...	17	—	C	
	10-20 WF 489	MEMBER , trailing edge, between ribs Nos. 22 and 23, Port	1	DTD.5020	—	LE2
	10-20 WF 490	MEMBER , trailing edge, between ribs Nos. 22 and 23, Starboard	1	DTD.5020	—	LE2

**MAIN PLANES
FLAPS, OUTER**

Ref. No.	Part No.	Description	No. off	Material Specification	Class of Store or L.M	Plate No.	
							1
15055	10-20 WF 521ND	PLATE , joint, at rib No. 22, Port, 22 SWG	1	L.73	LM	LE3	
	10-20 WF 522ND	PLATE , joint, at rib No. 22, Starboard, 22 SWG	1	L.73	LM	LE3	
	10-20 WF 488ND	PLATE , joint, at rib No. 23, Port, 20 SWG	1	L.73	LM	LE3	
	10-20 WF 487ND	PLATE , joint, at rib No. 23, Starboard, 20 SWG	1	L.73	LM	LE3	
	10-20 WF 1461A/ND	PLATE , striker, at leading edge, assembly ... (Mod. 745)	1	—	C	LE3	
	10-20 WF 283	RIB , nose, No. 22, Port	1	L.73	—	LE1	
	10-20 WF 284	RIB , nose, No. 22, Starboard	1	L.73	—	LE1	
	10-20 WF 285A	RIB , No. 23, Port, assembly ... (For spares use 10-20 WF 1165A/ND)	1	—	—	LE1	
	11160	10-20 WF 1165A/ND	RIB , No. 23, Port, assembly (Spares condition)	1	—	C	
		10-20 WF 286A	RIB , No. 23, Starboard, assembly ... (For spares use 10-20 WF 1166A/ND)	1	—	—	LE1
11161	10-20 WF 1166A/ND	RIB , No. 23, Starboard, assembly (Spares condition)	1	—	C		
	10-20 WF 337	BLOCK , trailing edge, Port	1	LFS.21	LM	LE1 LE3	
	10-20 WF 338	BLOCK , trailing edge, Starboard	1	LFS.21	LM	LE1 LE3	
		Attachments for 10-20 WF 337 or 10-20 WF 338, Block :—					
7367	DHS.358/10C	Bolt, 2 BA	1	—	C	LE3	
28M/13124	A27/CT	Nut, 2 BA	1	—	C		
7406	10-20 WF 351A	SKIN , bottom, Port, assembly	1	—	C	LE1	
7407	10-20 WF 352A	SKIN , bottom, Starboard, assembly	1	—	C	LE1	
	10-20 WF 349ND	SKIN , nose, Port, 20 SWG	1	L.73	LM	LE1	
	10-20 WF 350ND	SKIN , nose, Starboard, 20 SWG	1	L.73	LM	LE1	
	10-20 WF 1419A	SKIN , top forward, Port, assembly (Mod. 539) (For spares use 10-20 WF 1469A/ND)	1	—	—	LE1	
15457	10-20 WF 1469A/ND	SKIN , top forward, Port, assembly ... (Spares condition)	1	—	C		
	10-20 WF 1420A	SKIN , top forward, Starboard, assembly (Mod. 539) (For spares use 10-20 WF 1470A/ND)	1	—	—	LE1	
15458	10-20 WF 1470A/ND	SKIN , top forward, Starboard, assembly ... (Spares condition)	1	—	C		
14138	10-20 WF 1423A	SKIN , top rear, Port, assembly (Mod. 539)	1	—	C	LE1	
14139	10-20 WF 1424A	SKIN , top, rear, Starboard assembly (Mod. 539)	1	—	C	LE1	
	10-20 WF 353ND	SKIN , trailing edge, Port, 24 SWG	1	L.73	LM	LE1	
	10-20 WF 354ND	SKIN , trailing edge, Starboard, 24 SWG	1	L.73	LM	LE1	
	10-20 WF 289	SPAR , Port	1	L.73	—	LE1	
	10-20 WF 290	SPAR , Starboard	1	L.73	—	LE1	
		Attachments for 10-20 WF 955A/2 or 10-20 WF 956A/2 Flap :—					
14141	10-20 WF 1435	Bolt, special (Mod. 539)	1	—	C	LE2	
14140	10-20 WF 1407	Bolt, special (Mod. 539)	1	—	C	LE2	
6884	10-20 WF 65	Bolt, 1/2" BSF (Lock to DHS.514/D)	1	—	C	LE3	
14144	10-20 WF 1453	Bush, serrated (Mod. 539)	1	—	C	LE2	
28M/12930	A27/ES	Nut, 1/2" BSF	1	—	C		
28P/9429528	SP.9/CB	Pin, split	1	—	C		
28W/9419476	SP.15/G	Washer	1	—	C		
28W/9419456	SP.10/J	Washer (Mod. 539)	1	—	C		
12615	DHS.781/28/26	Washer	6	—	LM	LE2	
12616	DHS.781/46/26	Washer	6	—	C	LE2	
7409	10-20 WF 91	Washer, tab	1	—	C	LE3	

LE.1

SEE TEXT FOR SPARES CONDITION OF ITEMS MARKED THUS *

MAIN PLANE

FLAPS OUTER

RESTRICTED

LE.1

[AL63]

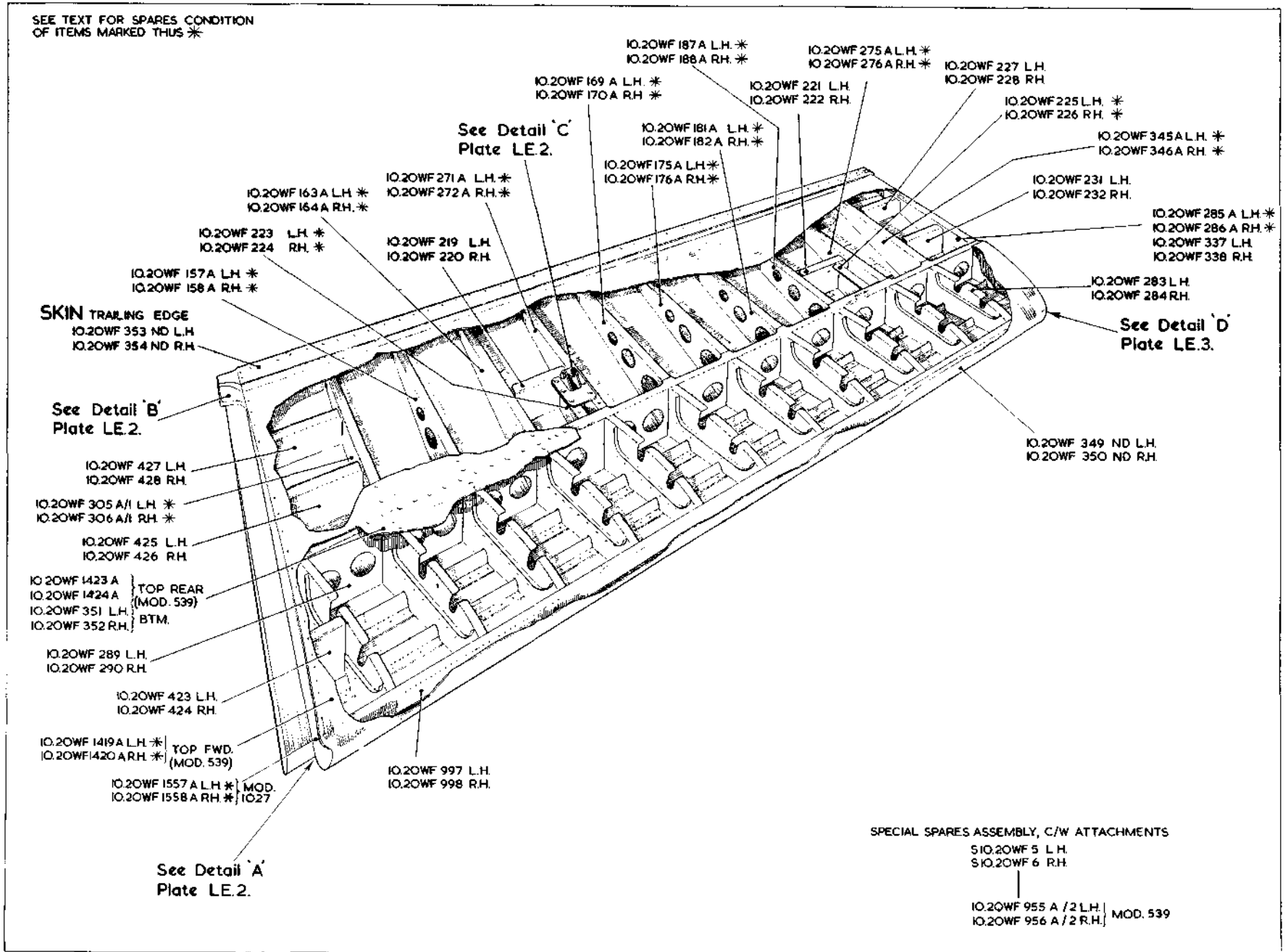

See Vixen Mk.1

RESTRICTED

Plate LE.1

SEE TEXT FOR SPARES CONDITION
OF ITEMS MARKED THUS: *

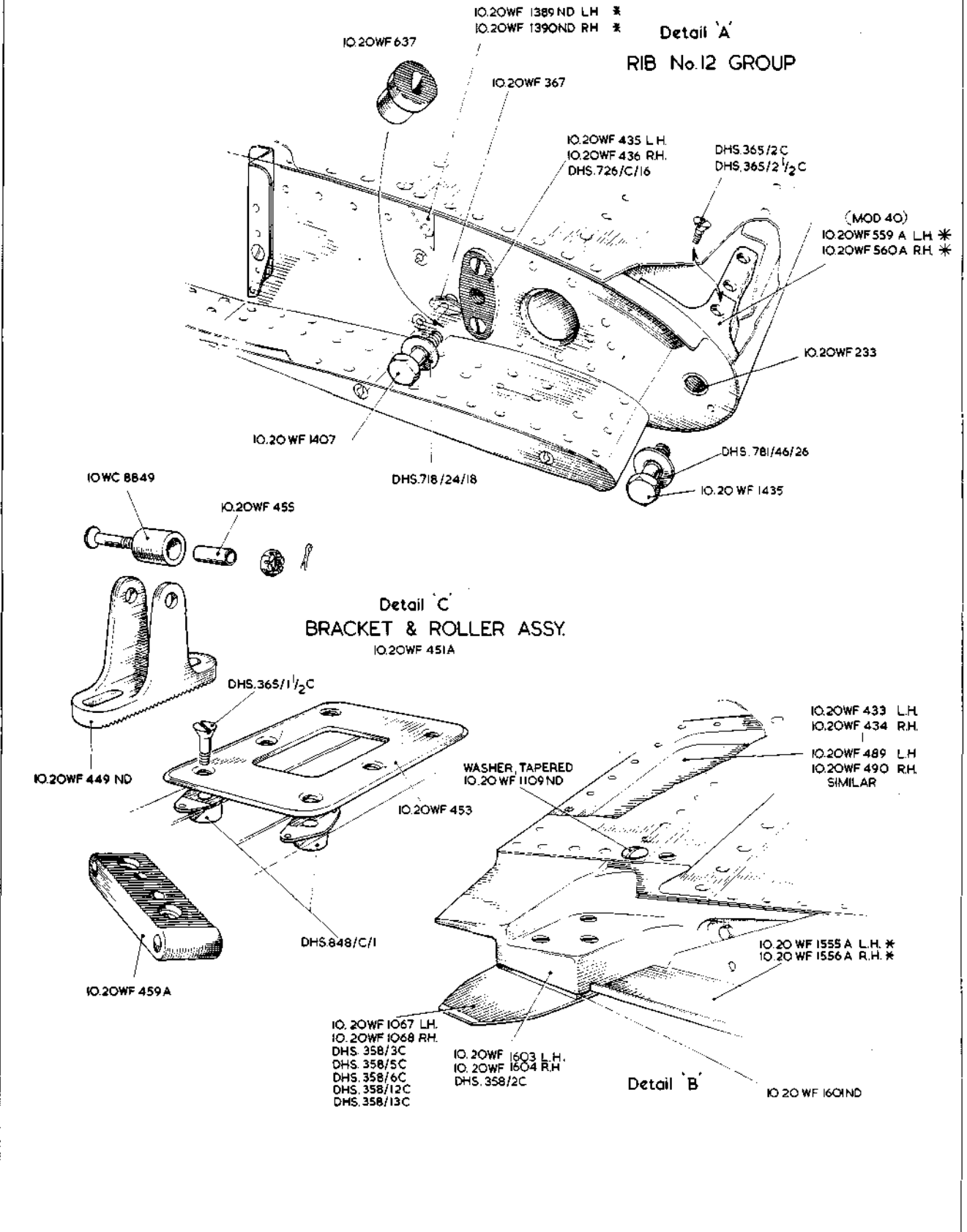

LE.2

MAIN PLANE

LE.2

FLAPS OUTER

[CAL 39]

SEE TEXT FOR SPARES CONDITION OF ITEMS MARKED THUS *

DHS.358/5 1/2 C
DHS.358/10C

TRAILING EDGE
DETAIL

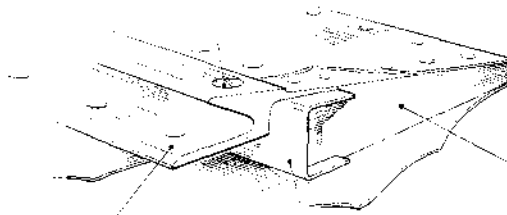

IO.20WF 357 L.H.
IO.20WF 358 R.H.

IO.20WF 355A L.H.*
IO.20WF 356A R.H.*
IO.20WF 135 ND *

BLOCKS, TRAILING EDGE

- IO.20WF 127 RIB No.14 L.H.
- IO.20WF 128 RIB No.14 R.H.
- IO.20WF 129 RIB No.16 L.H.
- IO.20WF 130 RIB No.16 R.H.
- IO.20WF 131 RIB No.18 L.H.
- IO.20WF 132 RIB No.18 R.H.
- IO.20WF 133 RIB No.20 L.H.
- IO.20WF 134 RIB No.20 R.H.
- IO.20WF 337 RIB No.23 L.H.
- IO.20WF 338 RIB No.23 R.H.
- IO.20WF 495 RIB No.23 L.H.
- IO.20WF 496 RIB No.23 R.H.

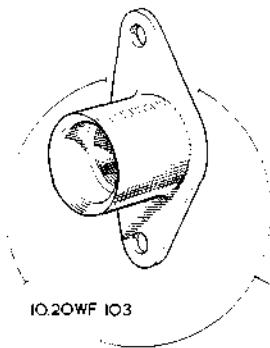

IO.20WF 103

PLATE, STRIKER
IO.20WF 1461A/ND

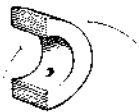

IO.20WF 319

IO.20WF 91

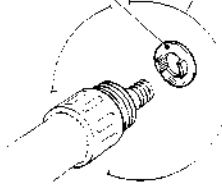

IO.20WF 521 ND L.H.
IO.20WF 522 ND R.H.

IO.20WF 488 ND L.H.
IO.20WF 487 ND R.H.

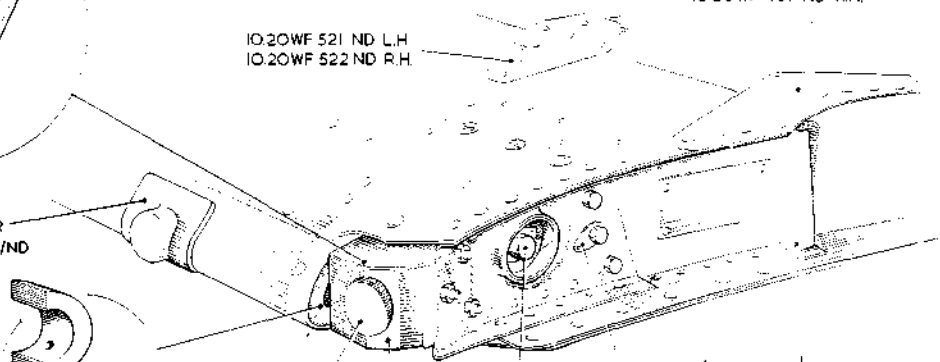

DHS.180. MK 3/X

Detail 'D'

IO.20WF 101A L.H.*
IO.20WF 102A R.H.*
DHS.365/2C

BRACKETS,
SKIN SUPPORT

- IO.20WF 493 L.H. } AFT
- IO.20WF 494 R.H. }
- IO.20WF 491 L.H. } FORWARD
- IO.20WF 492 R.H. }

IO.20WF 65/DHS.514/D

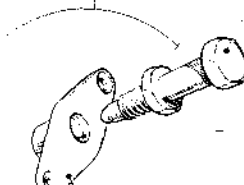

IO.20WF 497

LE.3

MAIN PLANE

FLAPS OUTER

LE.3

AL.24



This file was downloaded
from the RTFM Library.

Link: www.scottbouch.com/rtfm

Please see site for usage terms,
and more aircraft documents.