

**MAIN PLANES
FUEL BAY COWLING**

| Ref. No. | Part No. | Description | No. off | | | | | | Material Specification | Class of Store or L.M | Plate No. |
|-------------|-----------------|--|---------|---|---|---|---|------|------------------------|-----------------------|-----------|
| | | | 1 | 2 | 3 | 4 | 5 | 6 | | | |
| | — | INSTALLATION OF FUEL BAY COWLING ... | | | | | | | | | |
| | | (Drg. No. 10-20 WC 41881) | | | | | | | | | |
| 215 | S10-20 WC 39 | COWLING , door, bottom centre section, under main spar, Port, (Spares assembly, complete with attachments) (For aircraft Serial No. XJ.494 and subsequent) | | | | | | — | P | LG1 | |
| 217 | S10-20 WC 41 | COWLING , door, bottom centre section, under main spar, Port, (Spares assembly, complete with attachments) (0"-2 trim allowance (For aircraft Serial Nos. XJ.474 to XJ.493) | | | | | | — | P | LG1 | |
| | 10-20 WC 41115A | COWLING , door, assembly (Mod. 1275) | | | | | | — | — | LG1 | |
| | | Spares for :— | | | | | | | | | |
| | 10-20 WC 22571 | ANGLE , cable clip attachment, 20 SWG | | | | | | L.72 | LM | LG1 | |
| 7678 | 10 WC 7899 | BLOCK , locating, on bottom member | | | | | | — | C | LG1 | |
| | | Attachments for 10 WC 7899, Block :— | | | | | | | | | |
| | 28D/8325 | AS.1242/4E | | | | | | — | C | | |
| | 28M/10290 | AGS.2001/E/1 | | | | | | — | C | | |
| | 28W/9419405 | SP.15/E | | | | | | — | C | | |
| | 10-20 N 7275A | BRACKET , saddle clip attachment for condenser block cables, in bay No. 3, assembly | | | | | | — | — | LG1 | |
| | 10-20 N 7255ND | BRACKET , bare, 18 SWG | | | | | | L.72 | LM | LG1 | |
| 28M/11957 | AGS.2007/C/1 | NUT , 2 BA, anchor | | | | | | — | C | | |
| | 10-20 N 13571 | BRACKET , support, plug, in bat No. 5, 20 SWG | | | | | | L.72 | LM | LG1 | |
| 17465 | 10-20 P 8109A | DRAIN , fuel, assembly | | | | | | — | C | LG1 | |
| | | Attachments for 10-20 P 8109A, Drain :— | | | | | | | | | |
| | 28M/10288 | AGS.2001/C/1 | | | | | | — | C | | |
| | 10-20 P 8121ND | Plate , packing, 20 SWG | | | | | | L.72 | LM | LG1 | |
| 28S/1011490 | A32/C16 | Screw , BA | | | | | | — | C | | |
| 8W/9419475 | SP.15/C | Washer | | | | | | — | C | | |
| | — | ELECTRICAL COMPONENTS ... | | | | | | | | | |
| | | (See sub-section ECM) | | | | | | | | | |
| | — | FASTENER , toggle, group | | | | | | | | | |
| | | (Drg. No. 10-20 WC 12125) | | | | | | | | | |
| 20491 | 10-20 WC 41949A | SUPPORT , assembly | | | | | | — | C | LG1 | |
| | | Spares for :— | | | | | | | | | |
| 20492 | DHS.418/1/E/"42 | BUSH (See Repair section PA) | | | | | | — | C | LG1 | |
| | | Attachments for 10-20 WC 41949A, Support :— | | | | | | | | | |
| | 28D/9133011 | A25/2C | | | | | | — | C | | |
| | 28M/5808573 | A27/CS | | | | | | — | C | | |
| | 28P/9527619 | SP.90/C7 | | | | | | — | C | | |
| | 19679 | 10-20 EC 14101 | | | | | | — | C | LG1 | |
| | 28D/14522 | A25/23E | | | | | | — | C | | |
| | 28M/1011467 | A27/ES | | | | | | — | C | | |
| | 28P/9527619 | SP.90/C7 | | | | | | — | C | | |
| | 28W/9418921 | SP.13/E | | | | | | — | C | | |
| | 5K/1200716 | SP.40/B12 | | | | | | — | C | | |
| | 7906 | 10-20 WC 20015A | | | | | | — | C | LG1 | |
| | 7905 | 10-20 WC 20011A | | | | | | — | C | LG1 | |
| | | GROMMET , in outer skin for fuel drain | | | | | | — | C | | |
| | | HINGE , aft, assembly | | | | | | — | C | LG1 | |
| | | HINGE , centre, assembly | | | | | | — | C | LG1 | |

MAIN PLANES
FUEL BAY COWLING

| Ref. No. | Part No. | Description | No. off | Material Specification | Class of Score or L.M | Plate No. |
|-------------|--------------------|--|---------|------------------------|-----------------------|-----------|
| | | | | | | |
| 7904 | 10-20 WC 20007A | HINGE , front, assembly | 1 | — | C | LG1 |
| | DHS.418/2/G/".30 | Spares for:— BUSH , 0".437 o/d x 0".3095 i/d x 0".30 long | 2 | DTD.197 | LM | LG1 |
| | | Attachments for 10-20 WC 20015A, 10-20 WC 20011A or 10-20 WC 20007A, Hinge:— | | | | |
| 28D/9133011 | A25/2C | Bolt, 2 BA | 4 | — | C | |
| 7907 | DHS.901/14/EE | Bolt, shear | 2 | — | C | LG1 |
| 28M/9403520 | A27/CP | Nut, 2 BA | 4 | — | C | |
| 28M/13376 | A29/EP | Nut, 1/2" BSF | 2 | — | C | |
| 28W/9419402 | SP.13/C | Washer | 4 | — | C | |
| 28W/9419405 | SP.15/E | Washer | 2 | — | C | |
| | 10 FS 5239 | LABEL , 24 SWG | 1 | Alum. | LM | LG1 |
| | — | MOUNTING , condenser block, group ... | 1 | — | — | |
| | | (Drg. No. 10-20 WC 21787) | | | | |
| | 10-20 WC 21825ND | ANGLE , reinforcing, diaphragm, 20 SWG | 2 | L.72 | LM | LG1 |
| | 10-20 WC 21826ND | ANGLE , reinforcing, diaphragm, 30 SWG | 2 | L.72 | LM | LG1 |
| | 10-20 WC 21813ND | ANGLE , reinforcing, inboard stiffener, 20 SWG | 1 | L.72 | LM | LG1 |
| | 10-20 WC 22293ND | ANGLE , reinforcing, outboard stiffener, 20 SWG | 1 | L.72 | LM | LG1 |
| | 10-20 WC 21789A | BRACKET , strap attachment, aft, assembly | 2 | — | — | LG1 |
| | 10-20 WC 21799ND | BRACKET , bare, 16 SWG | 1 | L.72 | LM | LG1 |
| | 10-20 WC 21801ND | PLATE , throat, 10 SWG | 1 | L.72 | LM | LG1 |
| | | Attachments for 10-20 WC 21789A, Bracket:— | | | | |
| 28D/9133011 | A25/2C | Bolt, 2 BA | 2 | — | C | |
| 28M/9403520 | A27/CP | Nut, 2 BA | 2 | — | C | |
| 28W/9419475 | SP.15/C | Washer | 2 | — | C | |
| | 10-20 WC 21793A | BRACKET , strap attachment, forward, in-board, assembly | 1 | — | — | LG1 |
| | 10-20 WC 21797ND | BRACKET , bare, 16 SWG | 1 | L.72 | LM | LG1 |
| | 10-20 WC 21805ND | PLATE , throat, 10 SWG | 1 | L.72 | LM | LG1 |
| | 10-20 WC 21791A | BRACKET , strap attachment, forward, out-board, assembly | 1 | — | — | LG1 |
| | 10-20 WC 21795ND | BRACKET , bare, 16 SWG | 1 | L.72 | LM | LG1 |
| | 10-20 WC 21803ND | PLATE , throat, 10 SWG | 1 | L.72 | LM | LG1 |
| | | Attachments for 10-20 WC 21793A or 10-20 WC 21791A, Bracket:— | | | | |
| 28D/9453970 | A25/15C | Bolt, 2 BA | 2 | — | C | |
| 28M/9403520 | A27/CP | Nut, 2 BA | 2 | — | C | |
| | AS.2809/4/128 | Tube, distance, 1/2" o/d x 22 SWG x 1".28 long | 2 | L.62 | LM | |
| 28W/9419475 | SP.15/C | Washer | 2 | — | C | |
| | 10-20 WC 21811ND | DIAPHRAGM , 20 SWG | 2 | L.72 | LM | LG1 |
| | 10-20 WC 21819ND | STIFFENER , inboard, 20 SWG | 1 | L.72 | LM | LG1 |
| | 10-20 WC 21821ND | STIFFENER , outboard, 20 SWG | 1 | L.72 | LM | LG1 |
| | 10-20 WC 41867A/ND | PANEL , assembly... .. | 1 | — | — | LG1 |
| | 10-20 WC 12083ND | GUSSET , corner, 20 SWG | 1 | L.72 | LM | LG1 |

**MAIN PLANES
FUEL BAY COWLING**

| Ref. No. | Part No. | Description | No. off | Material Specification | Class of Store or L.M | Plate No. |
|----------|------------------|--|---------|------------------------|-----------------------|-----------|
| | | | | | | |
| 8386 | 10-20 WC 12079ND | GUSSET , corner, 20 SWG | 1 | L.72 | LM | LG1 |
| | 10-20 WC 14419ND | GUSSET , corner, 20 SWG | 1 | — | C | LG1 |
| | 10-20 WC 12069ND | MEMBER , aft end, 20 SWG (For spares use 10-20 WC 29309ND) | 1 | L.72 | — | LG1 |
| 14517 | 10-20 WC 29309ND | MEMBER , aft end, 20 SWG (Spares condition) | 1 | — | C | |
| 8390 | 10-20 WC 14455ND | MEMBER , front top, 18 SWG | 1 | — | C | LG1 |
| | 10-20 WC 40209ND | MEMBER , section, bottom, 20 SWG (Mods. 1066 and 797) | 1 | L.72 | — | LG1 |
| 15151 | 10-20 WC 12065ND | MEMBER , section, front end, 20 SWG (For spares use 10-20 WC 29589ND) | 1 | L.72 | — | LG1 |
| | 10-20 WC 29589ND | MEMBER , section, front end, 20 SWG (Spares condition) | 1 | — | C | |
| | 10-20 WC 30497ND | MEMBER , section, top, 20 SWG (For spares use 10-20 WC 31767ND) | 1 | L.72 | — | LG1 |
| | 10-20 WC 31767ND | MEMBER , section, top, 20 SWG (Spares condition) | 1 | L.72 | | |
| | 10 WC 6135 | PIECE , angle, at all members, 20 SWG ... | 17 | L.72 | LM | LG1 |
| | 10-20 WC 12073ND | PLATE , gusset, 20 SWG | 1 | L.72 | LM | LG1 |
| | 10 WC 7835ND | PLATE , reinforcing, 20 SWG | 1 | L.72 | LM | LG1 |
| | 10-20 WC 30487ND | PLATE , reinforcing, 20 SWG (For spares use 10-20 WC 31769ND) | 1 | L.72 | — | LG1 |
| | 10-20 WC 31769ND | PLATE , reinforcing, 20 SWG (Spares condition) | 1 | L.72 | — | |
| | 10-20 WC 30361ND | PLATE , reinforcing, 20 SWG | 1 | L.72 | — | LG1 |

MAIN PLANES
FUEL BAY COWLING

| Ref. No. | Part No. | Description | No. off | Material Specification | Class of Store or L.M | Place No. |
|-------------|------------------|---|---------|------------------------|-----------------------|-----------|
| | | | | | | |
| 13801 | 10 WC 7833A/2 | VENTILATOR , assembly | 2 | — | C | LG1 |
| | 10-20 WC 12049ND | SEAL , rubber, along top member (Make from rubber standard section J.335, Ref. No. 26FY/8551) | 1 | DHA.34 | LM | LG1 |
| | 10-20 WC 12043ND | Attachments for 10-20 WC 12049ND, Seal:— Strip, $\frac{1}{8}$ " x 22 SWG | 1 | L.72 | LM | LG1 |
| | 10-20 WC 12085ND | STRIP , packing, aft hinge member, 14 SWG | 1 | L.72 | LM | LG1 |
| | 10-20 WC 28887ND | STRIP , sealing, aft member, $\frac{3}{8}$ " x $\frac{1}{8}$ ", synthetic rubber, BSH. No. 110-120° | 1 | DHA.34 | LM | LG1 |
| 19234 | 10-20 WC 12087ND | STRIP , sealing, front member, 1"-0 x $\frac{1}{8}$ ", synthetic rubber, BSH. No. 110-120 | 1 | — | C | LG1 |
| | | Attachments for 10-20 WC 41115A, Cowling:— | | | | |
| 28P/1013112 | SP.4Y/F19 | Pin, shackle | 3 | — | C | |
| 28P/19128 | SP.90/E4 | Pin, split (SP.9/E6) | 3 | — | C | |
| 28W/9419476 | SP.15/G | Washer | 3 | — | C | |
| 218 | S10-22 WC 6 | COWLING , door, bottom, centre section, under main spar Starboard (Special spares assembly, c/w attachments) (0"-2 trim allowance) (For aircraft Serial Nos. XJ.474 to XJ.493) | 1 | — | P | LG2 |
| 216 | S10-22 WC 8 | COWLING , door, bottom, centre section, under main spar, Starboard (Special spares assembly, c/w attachments) (For aircraft Serial No. XJ.494 and subsequent) | 1 | — | P | LG2 |
| | 10-20 WC 41117A | COWLING , door assembly (Mod. 1275) ... | 1 | — | — | LG2 |
| | 10-20 WC 22571 | Spare for:— ANGLE , cable clip attachments, on aft hinge member, 20 SWG | 1 | L.72 | LM | LG2 |
| 7698 | 10 WC 7901 | BLOCK , locating, on bottom member ... | 2 | — | C | LG2 |
| | | Attachments for 10 WC 7901, Block:— | | | | |
| 28D/8325 | AS.1242/4E | Bolt, $\frac{1}{4}$ " BSF | 2 | — | C | |
| 28M/10290 | AGS.2001/E/1 | Nut, $\frac{1}{4}$ " BSF | 2 | — | C | |
| 28W/9419405 | SP.15/E | Washer | 2 | — | C | |
| | 10-20 WC 40281 | BRACKET , cable attachment, assembly ... | 3 | — | — | LG2 |
| | 10-20 WC 30651ND | Spare for:— CLIP (Make from Clip, Part No. AS.2295/2, (Ref. No. 28E/999659) | 1 | — | LM | LG2 |
| 28M/9435648 | AGS.2018/A/1 | NUT , anchor, 6 BA | 1 | — | C | |
| | 10-20 WC 30641ND | PLATE , angle, 18 SWG | 1 | L.72 | LM | LG2 |
| 28S/1200049 | A31/A12 | SCREW , 6 BA | 1 | — | C | |

**MAIN PLANES
FUEL BAY COWLING**

| Ref. No. | Part No. | Description | No. off | Material Specification | Class of Score or L.M | Plate No. |
|-------------|------------------|---|---------|------------------------|-----------------------|-----------|
| | | | | | | |
| | — | ELECTRICAL COMPONENTS | — | — | — | |
| | — | (See sub-section ECM) | | | | |
| | — | FASTENER , toggle, group | 3 | — | — | |
| | — | (Drg. No. 10-20 WC 41807) | | | | |
| 7701 | 10 WC 6675A | DOOR , assembly | 1 | — | C | LG3 |
| | | Spares for:— | | | | |
| 28FP/253 | DZUS FA5/40/2/DS | FASTENER , flat head | 1 | — | C | LG3 |
| 28FP/295 | DZUS GF5/175 | GROMMET , fastener | 1 | — | C | LG3 |
| 19678 | 10-20 WC 41137A | FASTENER , coggle, assembly | 1 | — | — | LG3 |
| | | Attachments for 10-20 WC 41137A, | | | | |
| | | Fastener:— | | | | |
| 28P/1015710 | SP.4Y/D8 | Pin, shackle | 2 | — | C | |
| 28P/1006943 | SP.9/C6 | Pin, split | 2 | — | C | |
| 28W/9418920 | SP.10/E | Washer, facing | 2 | — | C | |
| 28M/1007403 | A27/ET | NUT , lock | 1 | — | C | |
| 26DL/2450 | 3 EC 285A | PLATE , spring, assembly | 1 | — | C | LG3 |
| 20493 | 10-20 WC 41941 | SCREW , 1/4" BSF (Fit at stn. 240-0) | 1 | — | C | |
| 28S/— | AS.2991/8E | SCREW , 1/4" BSF (Fit at stn. 206-0 and 233-0) | 1 | — | C | |
| 20491 | 10-20 WC 41949A | SUPPORT , assembly | 2 | — | C | LG3 |
| | | Spares for:— | | | | |
| 20492 | DHS.418/1/E/42" | BUSH | 1 | — | C | LG3 |
| | | Attachments for 10-20 WC 41949A, | | | | |
| | | Support:— | | | | |
| 28D/1013284 | AS.1248/2C | Bolt, 2 BA | 2 | — | C | |
| 28M/9403520 | A27/CP | Nut, 2 BA | 2 | — | C | |
| | | GUSSET , corner, 20 SWG | 1 | L72 | LM | LG2 |
| 7684 | 10-20 WC 20016A | HINGE , aft, assembly | 1 | — | P | LG2 |
| 7683 | 10-20 WC 20012A | HINGE , centre, assembly | 1 | — | P | LG2 |
| 7682 | 10-20 WC 20008A | HINGE , forward, assembly | 1 | — | P | PG2 |
| | | Spares for:— | | | | |
| | | BUSH | 2 | DTD.197 | LM | LG2 |
| | | Attachments for 10-20 WC 20016A, 10-20 WC | | | | |
| | | 20012A or 10-20 WC 20008A, Hinge:— | | | | |
| 28D/9133011 | A25/2C | Bolt, 2 BA | 4 | — | C | |
| 7907 | DHS.901/14/EE | Bolt, shear | 2 | — | C | LG2 |
| 28M/9403520 | A27/CP | Nut, 2 BA | 4 | — | C | |
| 28M/13376 | A29/EP | Nut, 1/4" BSF | 2 | — | C | |
| 28W/9419402 | SP.13/C | Washer | 4 | — | C | |
| 28W/9419405 | SP.15/E | Washer | 2 | — | C | |

MAIN PLANES
FUEL BAY COWLING

| Ref. No. | Part No. | Description | No. off | Material Specification | Class of Store or L.M | Place No. |
|-------------|------------------|---|---------|------------------------|-----------------------|-----------|
| | | | | | | |
| | — | MOUNTING , condenser block, group ... (Drg. No. 10-20 WC 21787) | 1 | — | — | |
| | 10-20 WC 21825ND | ANGLE , reinforcing diaphragm, 20 SWG | 2 | L.72 | LM | LG3 |
| | 10-20 WC 21826ND | ANGLE , reinforcing diaphragm, 20 SWG | 2 | L.72 | LM | LG3 |
| | 10-20 WC 21824ND | ANGLE , reinforcing, inboard stiffener, 20 SWG | 1 | L.72 | LM | LG3 |
| | 10-20 WC 21823ND | ANGLE , reinforcing, outboard stiffener, 20 SWG | 1 | L.72 | LM | LG3 |
| | 10-20 WC 21789A | BRACKET , strap attachment, aft, assembly | 2 | — | — | LG3 |
| | 10-20 WC 21799ND | BRACKET , bare, 16 SWG ... | 1 | L.72 | LM | LG3 |
| | 10-20 WC 21801ND | PLATE , throat, 16 SWG ... | 1 | L.72 | LM | LG3 |
| | | Attachments for 10-20 WC 21789A, Bracket:- | | | | |
| 28D/9133011 | A25/2C | Bolt, 2 BA ... | 2 | — | C | |
| 28M/9403520 | A27/CP | Nut, 2 BA ... | 2 | — | C | |
| 28W/9419475 | SP.15/C | Washer ... | 2 | — | C | |
| | 10-20 WC 21794A | BRACKET , strap attachment, forward inboard, assembly | 1 | — | — | LG3 |
| | 10-20 WC 21798ND | BRACKET , bare, 16 SWG ... | 1 | L.72 | LM | LG3 |
| | 10-20 WC 21805ND | PLATE , throat, 10 SWG ... | 1 | L.72 | LM | LG3 |
| | 10-20 WC 21792A | BRACKET , strap attachment, forward outboard, assembly | 1 | — | — | LG3 |
| | 10-20 WC 21796ND | BRACKET , bare, 16 SWG ... | 1 | L.72 | LM | LG3 |
| | 10-20 WC 21803ND | PLATE , throat, 10 SWG ... | 1 | L.72 | LM | LG3 |
| | | Attachments for 10-20 WC 21794A or 10-20 WC 21792A, Bracket:- | | | | |
| 28D/9453970 | A25/15C | Bolt, 2 BA ... | 2 | — | C | |
| 28M/10288 | AGS.2001/C/1 | Nut, 2 BA ... | 2 | — | C | |
| | AS.2809/4/128 | Tube, distance, 1/2" o.d x 22 SWG x 1'-28 long | 2 | L.62 | LM | |
| 28W/9419475 | SP.15/C | Washer ... | 2 | — | C | |
| | 10-20 WC 21807ND | DIAPHRAGM , 20 SWG ... | 1 | L.72 | LM | LG3 |
| | 10-20 WC 21809ND | DIAPHRAGM , 20 SWG ... | 1 | L.72 | LM | LG3 |
| | 10-20 WC 21817ND | STIFFENER , inboard, 20 SWG ... | 1 | L.72 | LM | LG3 |
| | 10-20 WC 21815ND | STIFFENER , outboard, 20 SWG ... | 1 | L.72 | LM | LG3 |

**MAIN PLANES
FUEL BAY COWLING**

| Ref. No. | Part No. | Description | No. off | Material Specification | Class of Store or L.M. | Plate No. |
|------------------|-----------------------------|--|--------------|------------------------|------------------------|----------------|
| | | | | | | |
| | 10-20 WC 41855A/ND | PANEL , assembly... .. | 1 | — | — | LG2 |
| | 10-20 WC 12084ND | GUSSET , corner, 20 SWG | 1 | L.72 | LM | LG2 |
| | 10-20 WC 12137ND | MEMBER , aft end (For spares use 10-20 WC 29593ND) | 1 | — | — | LG2 |
| 15155 | 10-20 WC 29593ND | MEMBER , aft end (Spares condition) ... | 1 | — | C | |
| | 10-20 WC 41911A/ND | MEMBER , aft hinge and stiffener plate at Stn. 240", assembly | 1 | — | — | LG2 |
| | | Spares for :— | | | | |
| | 10-20 WC 41851ND | MEMBER , aft hinge (For spares use 10-20 WC 41857ND) | 1 | L.72 | — | LG2 |
| | 10-20 WC 41857 | MEMBER , aft hinge (Spares condition) | 1 | L.72 | — | |
| | 10-20 WC 12149ND | MEMBER , forward edge (For spares use 10-20 WC 29599ND) | 1 | L.72 | — | LG2 |
| 15154 | 10-20 WC 29599ND | MEMBER , forward edge (Spares condition) | 1 | — | C | |
| | 10-20 WC 14433ND | MEMBER , front lip (For spares use 10-20 WC 29603ND) | 1 | L.72 | — | LG2 |
| 15157 | 10-20 WC 29603ND | MEMBER , front lip (Spares condition) ... | 1 | — | C | |
| | 10-20 WC 30365ND | MEMBER , top | 1 | — | — | LG2 |
| | 10 WC 6135 | PIECE , angle, at all members where there are no hinge fittings, 20 SWG | 17 | L.72 | LM | LG3 |
| | 10-20 WC 12074ND | PLATE , corner gusset, 20 SWG | 1 | L.72 | LM | LG2 |
| | 10-20 WC 12080ND | PLATE , corner gusset, 20 SWG | 1 | L.72 | LM | LG2 |
| | 10-20 WC 12139ND | STIFFENER, middle (Pre Mod. 797) | 1 | L.72 | — | LG2 |
| | | (For spares use 10-20 WC 29207ND) | | | | |
| 14518 | 10-20 WC 29207ND | STIFFENER, middle (Spares condition) ... | 1 | — | C | — |
| | 10-20 WC 30357ND | STIFFENER , middle (Mod. 797) (For spares use 10-20 WC 31763ND) | 1 | L.72 | — | LG2 |
| | 10-20 WC 31763ND | STIFFENER , middle (Spares condition) ... | 1 | L.72 | — | |

**MAIN PLANES
FUEL BAY COWLING**

| Ref. No. | Part No. | Description | | | | | | No. off | Material Specification | Class of Store or LM | Place No. |
|-------------|---|---|---|---|---|---|---|---------|------------------------|----------------------|-----------|
| | | 1 | 2 | 3 | 4 | 5 | 6 | | | | |
| 17279 | 10-20 WC 41801 | PLATE , gusset, at bottom member, 20 SWG | | | | | | 3 | L.72 | LM | LG2 |
| | 10-20 WC 40271ND | PLATE , mounting | | | | | | 1 | — | — | LG2 |
| | 10-20 WC 40729ND | (For spares use 10-20 WC 40729ND) | | | | | | | | | |
| | 10 WC 6151ND | PLATE , mounting (Spares condition) ... | | | | | | 1 | — | C | |
| | 10-20 WC 1839ND | PLATE , packing, at ends of middle stiffener, 20 SWG | | | | | | 2 | L.72 | LM | LG2 |
| | | SEAL , rubber, bottom member (Make from Neoprene X.73, Ref. No. 26 FY 16402) | | | | | | 1 | — | LM | LG2 |
| | | Attachments for 10-20 WC 1839ND, Seal :— | | | | | | | | | |
| | | Screw, 3/8" long, round head | | | | | | 15 | — | C | |
| | | Strip, 22 SWG | | | | | | 1 | L.72 | LM | LG2 |
| | | SEAL , rubber, top members (Make from standard section J.335, Ref. No. 26FY/8551) | | | | | | 1 | DHA.34 | LM | LG2 |
| | Attachments for 10-20 WC 12049ND, Seal :— | | | | | | | | | | |
| | Strip, 22 SWG | | | | | | 1 | L.72 | LM | LG2 | |
| 17280 | 10-20 WC 40273 | RING , reinforcing | | | | | | 1 | — | C | LG2 |
| | 10-20 N 20101 | SOCKET , bonding, assembly | | | | | | 3 | — | LM | LG2 |
| 5X/7331 | PLESSEY 2CZ.109945 | INSERT , socket | | | | | | 1 | — | C | LG2 |
| 5X/9400079 | — | TERMINATION , lug | | | | | | 1 | — | C | LG2 |
| | 10-20 WC 12081ND | STIFFENER , at bay No. 1 (Make from standard section J.205) | | | | | | 3 | — | LM | LG2 |
| | 10-20 WC 1818ND | STIFFENER , at bay No. 6 (Make from standard section J.205) | | | | | | 1 | — | LM | LG2 |
| | 10-20 WC 1820ND | STIFFENER , at bay No. 6 (Make from standard section J.205) | | | | | | 1 | — | LM | LG2 |
| | 10-20 WC 1835ND | STRIP , sealing, front lip member (Synthetic rubber, shore hardness 110-120°) 1" x 1/8" | | | | | | 1 | DHA.34 | LM | LG2 |
| | 10-20 WC 28889ND | STRIP , sealing, aft end member (Synthetic rubber, shore hardness 110-120°) 3/4" x 3/8" | | | | | | 1 | DHA.34 | LM | LG2 |
| | Attachments for 10-20 WC 41117A, Cowling :— | | | | | | | | | | |
| 28P/1013112 | SP.4Y/F19 | Pin, shackle | | | | | | 3 | — | C | |
| 28P/19128 | SP.90/E4 | Pin, split (SP.9/E6) | | | | | | 3 | — | C | |
| 28W/9419476 | SP.15/G | Washer | | | | | | 3 | — | C | |
| | 10-20 N 20099 | LEAD , bonding flexible, underwing shear panel, assembly | | | | | | 3 | — | LM | LG2 |
| 5K/1489 | PLESSEY 16/4"-0048 | BRAID , flexible, tinned copper | | | | | | QR | — | C | LG2 |
| 5X/3242 | PLESSEY Z.28147 | PIN , plug | | | | | | 1 | — | C | LG2 |
| 6380 | DHS.181/4 | TUBING , 4 m/m., i/d | | | | | | QR | — | C | LG2 |
| 5X/9400079 | — | TERMINATION , lug | | | | | | 1 | — | C | LG2 |
| | Attachments for 10-20 N 20099, Lead :— | | | | | | | | | | |
| 28D/9138768 | A25/1/3C | Bolt, 2 BA | | | | | | 1 | — | C | |
| 28M/10288 | AGS.2001/C/1 | Nut, 2 BA | | | | | | 1 | — | C | |
| 20243 | 10-20 WC 41799A | SLING , aft, assembly | | | | | | 1 | — | P | LG4 |
| 20242 | 10-20 WC 41797A | SLING , centre, assembly | | | | | | 1 | — | P | LG4 |
| 20241 | 10-20 WC 41795A | SLING , forward, assembly | | | | | | 1 | — | P | LG4 |

**MAIN PLANES
FUEL BAY COWLING**

| Ref. No. | Part No. | Description | No. of | Material Specification | Class of Store or L.M. | Plate No. |
|--------------|-----------------|---|--------|------------------------|------------------------|-----------|
| | | | | | | |
| | | Spares for :— | | | | |
| 20244 | 10-20 WC 41837 | BAR , tie | 1 | — | C | LG4 |
| 7901 | 10 FS 4665 | BUSH , link end | 1 | — | C | LG4 |
| 19674 | 10-20 WC 41141A | FASTENER , toggle, assembly | 3 | — | — | LG4 |
| 19662 | 10-20 EC 14061 | HOOK | 1 | — | C | LG4 |
| 28M/1011470 | A27/GT | NUT , lock | 1 | — | C | LG4 |
| 19675 | 10-20 EC 14107 | SWIVEL | 1 | — | C | LG4 |
| 19677 | 10-20 WC 41135 | FORK-END | 1 | — | C | LG4 |
| | 10 FS 4523A | LINK-END , assembly | 1 | — | — | LG4 |
| | AS.2371/J.50 | Spares for :— | | | | |
| | | BUSH , knurled, $\frac{1}{2}$ " o/d \times $\frac{3}{8}$ " i/d \times $\frac{1}{2}$ " long | 1 | S.2 | LM | LG4 |
| | | Attachments for 10 FS 4523, Link-end :— | | | | |
| 26FC/6751 | DHS.94/5/90 | Pin, ground steel, $\frac{3}{8}$ " dia. | 3 | — | C | LG4 |
| 28M/1011470 | A27/GT | NUT , $\frac{1}{4}$ " BSF, R.H., thread, tension rod (Lock thread, DHS.514/D) | 1 | — | C | |
| 28M/13464 | A27/GTL | NUT , $\frac{1}{4}$ " BSF, L.H., thread, tension rod (Lock to DHS.514/D) | 1 | — | C | |
| 28FP/1048017 | AGS.2106/413 | PIN , quick release | 1 | — | C | LG4 |
| 28P/1134 | SP.4Y/K18 | PIN , shackle, $\frac{1}{8}$ " | 1 | — | C | |
| 28P/19157 | SP.90/G10 | PIN , split, retaining shackle pin (SP.9/G12) | 1 | — | C | |
| | 10 FS 4669 | PLUG-END | 1 | L.65 | — | LG4 |
| | | Attachments for 10 FS 4669, Plug-end :— | | | | |
| 26FC/6751 | DHS.94/5/90 | Pin, ground steel, $\frac{3}{8}$ " dia. | 3 | — | C | LG4 |
| 19676 | 10-20 WC 41133 | ROD , tension | 1 | — | C | LG4 |
| | 10 FS 4701 | UNIVERSAL-END , fitted to aft and centre slings only | 1 | L.65 | — | LG4 |
| | 10-20 WC 20117 | UNIVERSAL-END , fitted to forward sling only | 1 | L.65 | — | LG4 |
| | | Attachments for 10 FS 4701 or 10-20 WC 20117 | | | | |
| | | Universal End :— | | | | |
| 7898 | 10 FS 4711 | Bolt, shouldered | 1 | — | C | LG4 |
| 28M/5808573 | A27/CS | Nut, 2 BA | 1 | — | C | |
| 28P/9486478 | SP.90/C5 | Pin, split (SP.9/C6) | 1 | — | C | |
| 28W/9128924 | SP.14/C | Washer | 1 | — | C | |
| | | Attachments for 10-20 WC 41799A, 10-20 WC 41797A or 10-20 WC 41795A, Sling :— | | | | |
| 28P/9483204 | SP.4Y/D10 | Pin, shackle | 1 | — | C | |
| 28P/9527619 | SP.90/C7 | Pin, split (SP.9/C8) | 1 | — | C | |
| 28W/9419405 | SP.15/E | Washer | 1 | — | C | |
| | — | STRAP , condenser, Port door, group | 1 | — | — | |
| | 10-20 WC 25917 | INSERT , plain | 2 | S.92 | LM | LG4 |
| | 10-20 WC 25919 | INSERT , screwed | 2 | S.92 | LM | LG4 |
| 10690 | 10-20 WC 25915 | SCREW | 2 | — | C | LG4 |
| 7702 | 10-20 WC 22169A | STRAP , assembly | 2 | — | C | LG4 |
| 10689 | 10-20 WC 25913A | STRAP , assembly | 2 | — | C | LG4 |
| | | Attachments for 10-20 WC 22169A, and 10-20 WC 25913A, Straps (per pair) :— | | | | |
| 28FP/9469298 | AGS.2105/407 | Pin, "Pip," quick release | 2 | — | C | LG4 |

**MAIN PLANES
FUEL BAY COWLING**

| Ref. No. | Part No. | Description | No. off | Material Specification | Class of Store or L.M. | Plate No. |
|--------------|-----------------|--|---------|------------------------|------------------------|-----------|
| | | | | | | |
| | — | STRAP , condenser, Starboard door, group ... | 1 | — | — | |
| 16712 | 10-20 WC 31419 | ANCHOR , strap, attachment ... | 2 | — | C | LG4 |
| | 10-20 WC 25917 | INSERT , plain... .. | 2 | S.92 | LM | LG4 |
| | 10-20 WC 25919 | INSERT , screwed | 2 | S.92 | LM | LG4 |
| 10690 | 10-20 WC 25915 | SCREW (Rear straps) | 1 | — | C | LG4 |
| 16711 | 10-20 WC 31417 | SCREW (Front straps) | 1 | — | C | LG4 |
| 16713 | 10-20 WC 31409A | STRAP , assembly, inboard, forward ... | 1 | — | C | LG4 |
| 16714 | 10-20 WC 31413A | STRAP , assembly, outboard, forward ... | 1 | — | C | LG4 |
| 10689 | 10-20 WC 25913A | STRAP , assembly, rear | 2 | — | C | LG4 |
| | | Attachments for 20-10 WC 31409A, 10-20 WC 31413A or 10-20 WC 25913A, Strap (per pair) :— | | | | |
| 28FP/9469298 | AGS.2105/407 | Pin, "Pip," quick release, rear | 2 | — | C | |
| 28P/865 | SP.4Y/D7 | Pin, shackle, forward | 2 | — | C | |
| 28P/9527619 | SP.90/C7 | Pin, split (SP.9/C8) | 2 | — | C | |
| 28W/9418920 | SP.10/E | Washer | 2 | — | C | |

LG.2

SEE TEXT FOR SPARES CONDITION
OF ITEMS MARKED THUS: *.

ITEMS MARKED THUS ⊕
PART OF PANEL
SUB-ASSY IO.20WC 41855 A/ND

COWLING, DOOR

SIO 22WC 8
OR
SIO 22WC 6 } SPARES ASSEMBLY
C/W ATTACHMENTS

DOOR ASSEMBLY
IO.20 WC 41117A

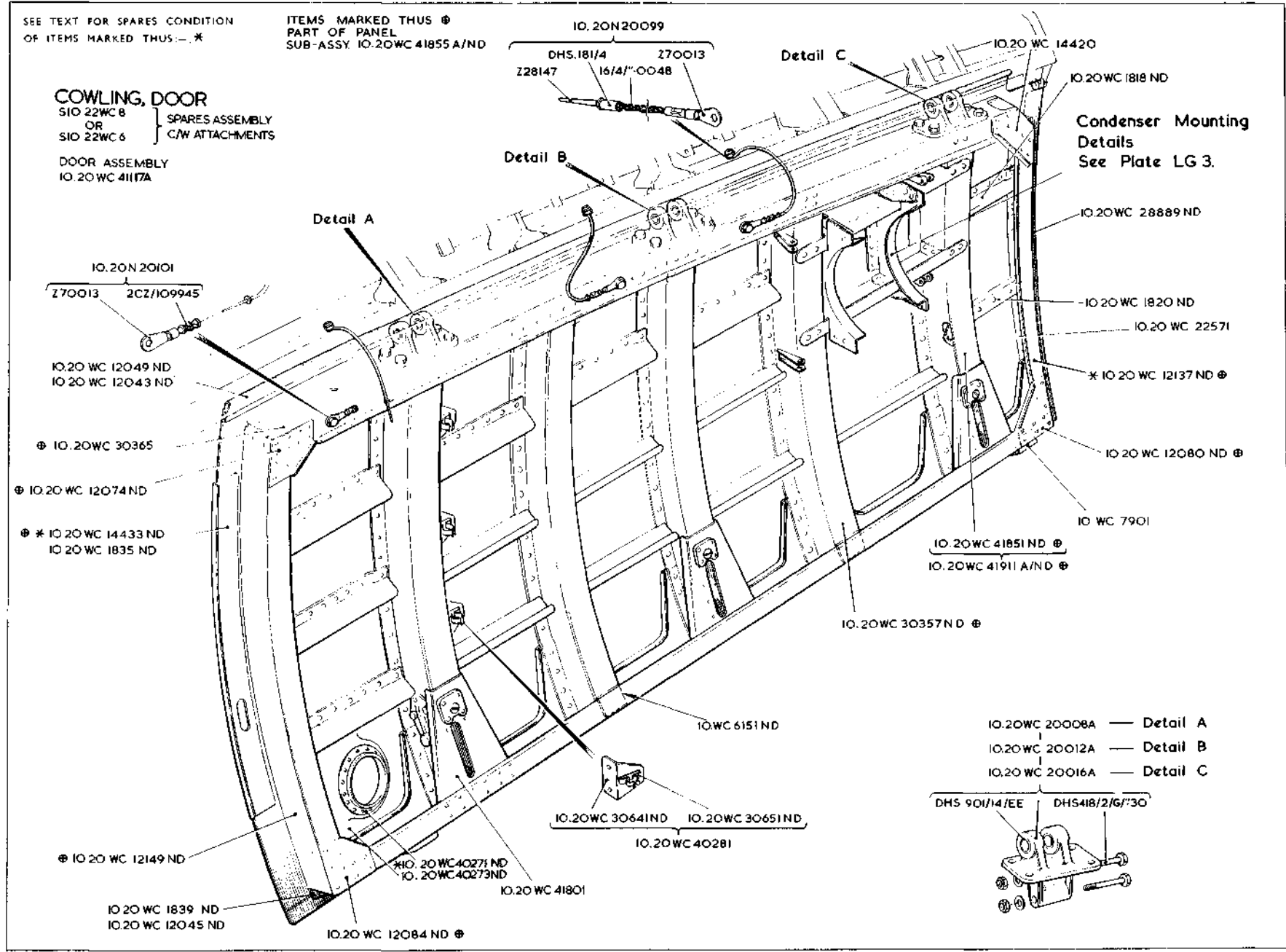

FUEL BAY COWLING

MAIN PLANE

RESTRICTED

LG.2
(A.171)

- IO.20WC 20008A — Detail A
- IO.20WC 20012A — Detail B
- IO.20WC 20016A — Detail C

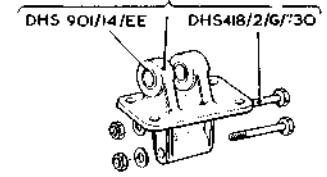

See Vixen Plk. 1

RESTRICTED

Plate LG.2

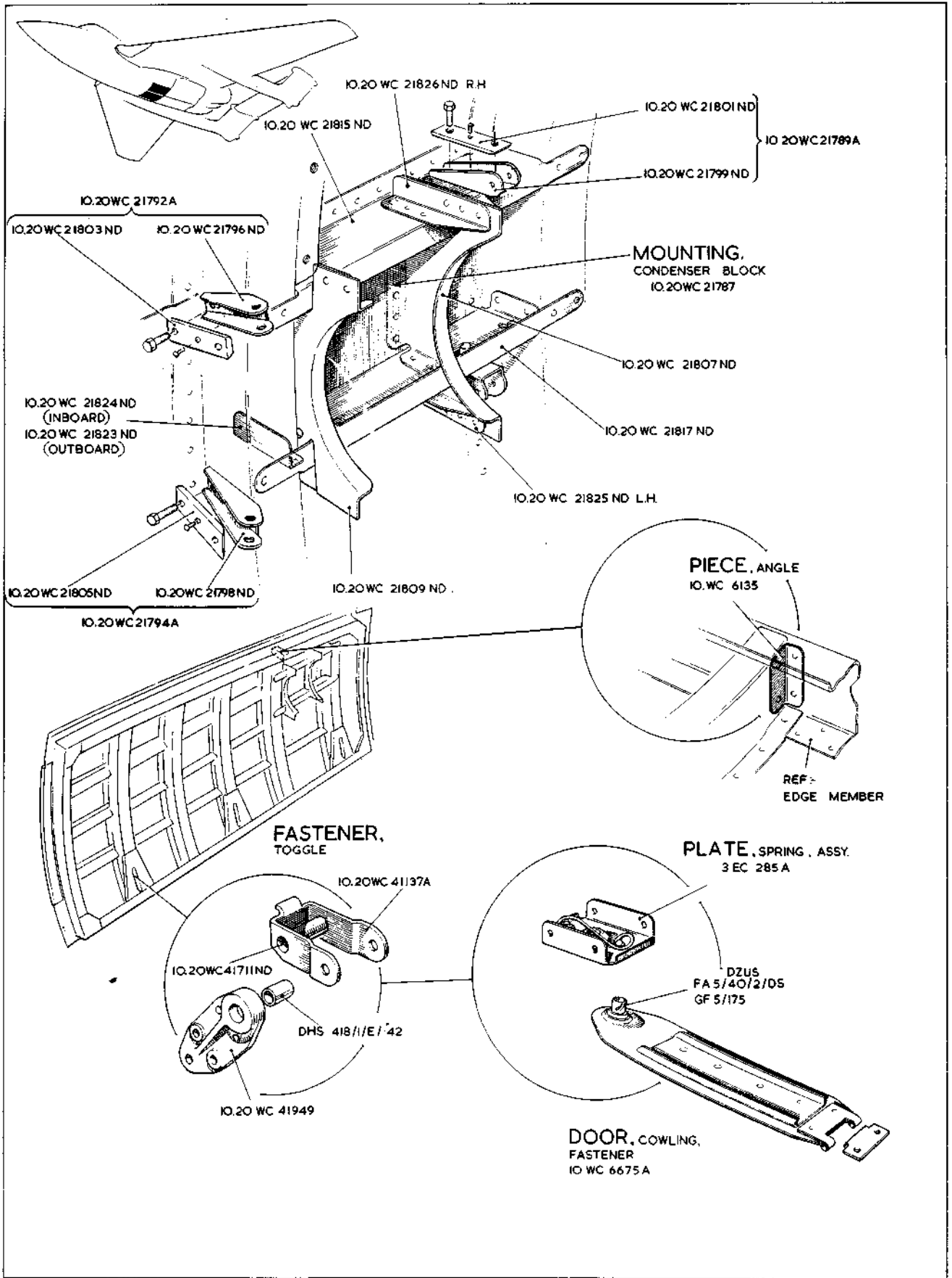

LG.3

MAIN PLANE
FUEL BAY COWLING

LG.3
[A.L.69]

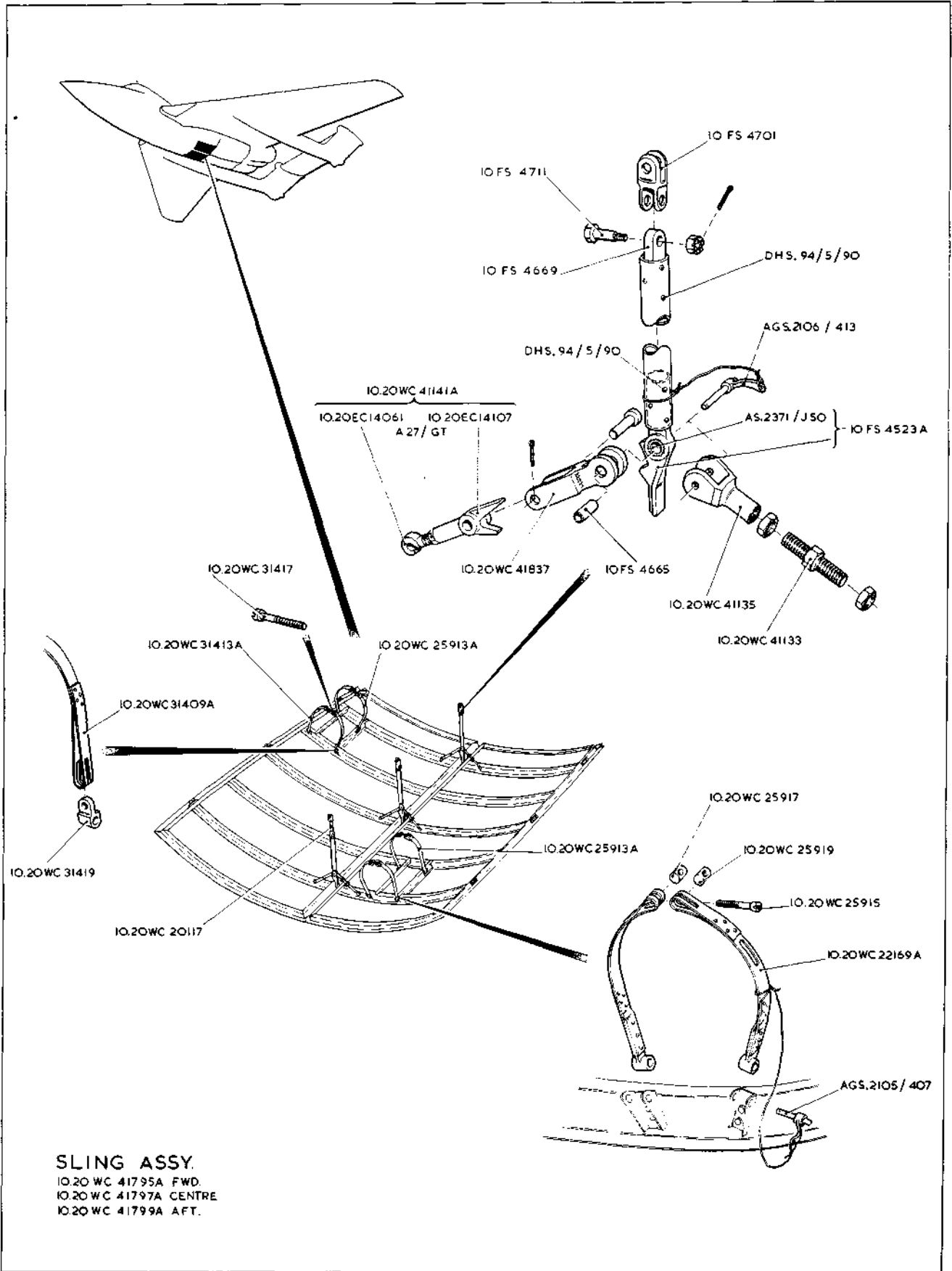

LG. 4

**MAIN PLANES
FUEL BAY COWLING**

LG 4
[ALL 75]



ROLLS-ROYCE

This file was downloaded
from the RTFM Library.

Link: www.scottbouch.com/rtfm

Please see site for usage terms,
and more aircraft documents.

ENGINE
INHIBITED
DO NOT
TURN
PROP