

**POWER INSTALLATION
ENGINE FRONT MOUNTING**

Ref. No.	Part No.	Description	No. off	Material Specification	Class of Store or L.M.	Plate No.
	—	ENGINE FRONT MOUNTING (Drg. No. 10-20 EM 249) Spares for :—	1	—	—	MD1
	10-20 EM 671A/ND	BEAM , lower engine cowling landing, between stations 250" and 300", Port, assembly (For spares use 10-20 EM 675A/ND) (Mod. 1203)	1	—	—	MD1
18802	10-20 EM 675A/ND	BEAM , lower engine cowling landing, between stations 250" and 300", Port, assembly (Spares condition) Spares for :—	1	—	P	
	10-20 EM 199A	BRACKET , angle, aft, assembly Spares for :—	1	—	—	MD1
	10-20 EM 221ND	BRACKET , angle, bare, 18 SWG	1	L.72	LM	MD1
	10-20 EM 223ND	PACKING , 16 SWG	1	L.72	LM	MD1
	10-20 EM 197A	BRACKET , angle, forward, assembly Spares for :—	1	—	—	MD1
	10-20 EM 217ND	BRACKET , angle, bare, 18 SWG	1	L.72	LM	MD1
	10-20 EM 219ND	PACKING , 16 SWG	1	L.72	LM	MD1
	10-20 EC 10003	BRACKET , strut retaining, cowl door, Port, 16 SWG Attachments for 10-20 EC 10003, Bracket :—	1	L.72	LM	MD1
28D/1010658	A25/1B	Bolt, 4 BA	2	—	C	
28M/10287	AGS.2001/B/1	Nut, 4 BA	2	—	C	
28W/9419465	SP.13/B	Washer	2	—	C	
6064	10-20 E 2059	ELBOW , drain Attachments for 10-20 E 2059, Elbow :—	1	S.15	C	MD1
28D/9436920	A25/1C	Bolt, 2 BA	2	—	C	
28M/10288	AGS.2001/C/1	Nut, 2 BA	2	—	C	
13519	10-20 E 5225	OUTLET , combined drain Attachments for 10-20 E 5225, Outlet :—	1	—	C	MD1
28M/10287	AGS.2001/B/1	Nut, 4 BA	4	—	C	
28S/1007469	A33/B14	Screw, 4 BA	4	—	C	
	10-20 EM 207ND	PLATE , tie, 18 SWG	1	L.72	LM	MD1
	10-20 EM 513ND	STIFFENER , front (For spares use 10-20 EM 575ND)	1	L.72	—	MD1
12596	10-20 EM 575ND	STIFFENER , front (Spares condition)	1	L.72	C	
	10-20 EM 515ND	STIFFENER , rear (For spares use 10-20 EM 577ND)	1	L.72	—	MD1
12597	10-20 EM 577ND	STIFFENER , rear (Spares condition)	1	L.72	C	
	10-20 EM 229ND	STRIP , rubbing, aft, 1/32" thick	1	LFS.21	LM	MD1
	10-20 EM 227ND	STRIP , rubbing, forward, 1/32" thick	1	LFS.21	LM	MD1
	10-20 EM 673A/ND	BEAM , lower engine cowling landing, between stations 250" and 300", Starboard, assembly (For spares use 10-20 EM 677A/ND) (Mod. 1203)	1	—	—	MD1
18803	10-20 EM 677A/ND	BEAM , lower engine cowling landing, between stations 250" and 300", Starboard, assembly (Spares condition) Spares for :—	1	—	P	
	10-20 EM 195A	BRACKET , angle, aft, assembly	1	—	—	MD1

**POWER INSTALLATION
ENGINE FRONT MOUNTING**

Ref. No.	Part No.	Description	No. of						Material Specification	Class of Store or L.M.	Place No.
			1	2	3	4	5	6			
		Spares for :—									
	10-20 EM 213ND	BRACKET , angle, bare, 18 SWG					1	L.72	LM	MD1	
	10-20 EM 215ND	PACKING , 16 SWG					1	L.72	LM	MD1	
	10-20 EM 193A	BRACKET , angle, forward, assembly					1	—	—	MD1	
		Spares for :—									
	10-20 EM 209ND	BRACKET , angle, bare, 18 SWG					1	L.72	LM	MD1	
	10-20 EM 211ND	PACKING , 18 SWG					1	L.72	LM	MD1	
	10-20 EC 10191	BRACKET , struc retaining, cowl door, Starboard, 16 SWG					1	L.72	LM	MD1	
		Attachments for 10-20 EC 10191, Bracket :—									
28D/1010658	A15/1B	Bolt, 4 BA					1	—	C		
28D/8300	AS.1242/1B	Bolt, 4 BA					1	—	C		
28M/10287	AGS.2001/B/1	Nut, 4 BA					2	—	C		
28W/9419465	SP.13/B	Washer					2	—	C		
6064	10-20 E 2059	ELBOW , drain					1	S.15	C	MD1	
10648	10-20 E 4911	ELBOW , drain					2	DHE.223 or 228	C	MD1	
		Attachments for 10-20 E 2059 or 10-20 E 4911, Elbow :—									
28D/9436920	A25/1C	Bolt, 2 BA					2	—	C		
28M/10288	AGS.2001/C/1	Nut, 2 BA					2	—	C		
13521	10-20 E 5221	OUTLET , drain					2	DHE.223	C	MD1	
13520	10-20 E 5227	OUTLET , drain					1	—	C	MD1	
		Attachments for 10-20 E 5221 or 10-20 E 5227, Outlet :—									
28M/10287	AGS.2001/B/1	Nut, 4 BA					4	—	C		
28S/1007469	A33/B14	Screw, 4 BA					4	—	C		
	10-20 EM 208ND	PLATE , tie, 18 SWG					1	L.72	LM	MD1	
	10-20 EM 517ND	STIFFENER , front (For spares use 10-20 EM 579ND)					1	L.72	—	MD1	
12598	10-20 EM 579ND	STIFFENER , front (Spares condition)					1	L.72	C		
	10-20 EM 519ND	STIFFENER , rear (For spares use 10-20 EM 581ND)					1	L.72	—	MD1	
12599	10-20 EM 581ND	STIFFENER , rear (Spares condition)					1	L.72	C		
	10-20 EM 233ND	STRIP , rubbing, aft, $\frac{1}{8}$ " thick					1	LFS.21	LM	MD1	
	10-20 EM 231ND	STRIP , rubbing, forward, $\frac{1}{8}$ " thick					1	LFS.21	LM	MD1	
		Attachments for 10-20 EM 671A/ND or 10-20 EM 673A/ND, Beam :—									
28D/1011029	A25/1E	Bolt, $\frac{1}{2}$ " BSF					4	—	C		
28D/1011238	A25/3E	Bolt, $\frac{1}{2}$ " BSF					6	—	C		
28D/9133208	A25/20E	Bolt, $\frac{1}{2}$ " BSF					1	—	C		
28D/9436920	A25/1C	Bolt, 2 BA					2	—	C		
28D/1007975	AS.1242/1C	Bolt, 2 BA					4	—	C		
28D/1011467	A27/ES	Nut, $\frac{1}{2}$ " BSF					7	—	C		
28M/10288	AGS.2001/C/1	Nut, 2 BA					2	—	C		
28M/10290	AGS.2001/E1	Nut, $\frac{1}{2}$ " BSF					4	—	C		
28M/9637	AGS.2003/C/1	Nut, 2 BA					2	—	C		
28M/13481	AGS.2020/C/1	Nut, 2 BA					2	—	C		
28P/107741	SP.9/C8	Pin, split					4	—	C		
28W/9418921	SP.13/E	Washer					7	—	C		
28W/9419475	SP.15/C	Washer					2	—	C		

**POWER INSTALLATION
ENGINE FRONT MOUNTING**

Ref. No.	Part No.	Description	No. off	Material Specification	Class of Store or L.M	Plate No.
	10-20 EM 251	SPACER , flanged, between stiffeners at beam attachment bolt (For spares use 10-20 EM 573ND)	2	L.53	—	MD1
12945	10-20 EM 573ND	SPACER , flanged, between stiffeners at beam attachment bolt (Spares condition)	2	—	C	
	—	STOWAGE , drain, engine, 6th stage compressor, group (Mod. 1203) (Drg. 10-20 EM 669)	1	—	—	
18805	10-20 E 8271	ADAPTER , stowage Attachments for 10-20 E 8271, Adapter :—	1	—	C	MD1
28D/9133012	A25/3C	Bolt, 2 BA	3	—	C	
28M/10288	AGS.2001/C/1	Nut, 2 BA	3	—	C	
28W/9419404	SP.16/C	Washer	3	—	C	
18804	10-20 E 8269	BRACKET , mounting Attachments for 10-20 E 8269, Bracket :—	1	—	C	MD1
28D/9133012	A25/3C	Bolt, 2 BA	2	—	C	
28M/10288	AGS.2001/C/1	Nut, 2 BA	2	—	C	
28W/9419475	SP.15/C	Washer	2	—	C	
28E/14242	AS.5418/7	CLIP , "P," hose, Port Attachments for AS.5418/7, Clip :—	1	—	C	
28D/9133013	A25/5C	Bolt, 2 BA	1	—	C	
28M/10288	AGS.2001/C/1	Nut, 2 BA	1	—	C	
28W/9419404	AS.2811/5/030 SP.16/C	Piece, distance, $\frac{3}{8}$ " o'd x 17 SWG x 0 ⁰⁰ 30 long Washer	1 1	L.62 —	LM C	
10648	10-20 E 4911	ELBOW , drain Attachments for 10-20 E 4911, Elbow :—	2	—	C	MD1
28D/9436920	A25/1C	Bolt, 2 BA	2	—	C	
28M/10288	AGS.2001/C/1	Nut, 2 BA	2	—	C	
28W/9419475	SP.15/C	Washer	2	—	C	
13519	10-20 E 5225	OUTLET , drain, Port	1	—	C	MD1
13520	10-20 E 5227	OUTLET , drain, Starboard Attachments: for 10-20 E 5225 or 10-20 E 5227, Outlet :—	1	—	C	MD1
28M/10287	AGS.2001/B/1	Nut, 4 BA	4	—	C	
28S/1007469	A33/B14	Screw, 4 BA	4	—	C	
28W/9419474	SP.15/B	Washer	4	—	C	
26FN/3285	DHS.180 Mk.3/X	TAG , locking	1	—	C	
6067	10-20 EM 275A	STRUT , front, engine mounting, assembly	2	—	P	MD1
	10-20 EM 201	FORK-END	1	S.92	—	MD1
	10-20 EM 277	FORK-END	1	S.92	—	MD1
26FN/2850	DHS.94/8/145	PIN , ground steel, $\frac{1}{4}$ " dia.	8	—	C	MD1
	10-20 EM 279ND	TUBE	1	T.45	—	MD1
		Attachments for 10-20 EM 275A, Strut :—				
6360	DHS.382/17J	Bolt, $\frac{3}{8}$ " BSF	2	—	C	MD1
6361	DHS.382/18J	Bolt, $\frac{3}{8}$ " BSF	2	—	C	MD1
28M/14833	A58/JS	Nut, $\frac{3}{8}$ " BSF	2	—	C	
28P/9527619	SP.90/C7	Pin, split (SP.9/C8)	2	—	C	
	AS.2808/8/110	Tube, distance, Port, $\frac{1}{2}$ " o'd x 17 SWG x 1 ⁰⁰ 10 long	2	T.35 or 45	LM	
	AS.2808/8/125	Tube distance, Starboard, $\frac{1}{2}$ " o'd x 17 SWG x 1 ⁰⁰ 25 long	2	T.35 or 45	LM	
28W/9419466	SP.13/J	Washer	2	—	C	

POWER INSTALLATION
ENGINE FRONT MOUNTING

Ref. No.	Part No.	Description						No. off	Material Specification	Class of Store or L.M	Place No.
		1	2	3	4	5	6				

SEE TEXT FOR SPARES CONDITION OF ITEMS MARKED THUS—*

ENGINE FRONT MOUNTING. IO.20 EM 249.

MD.1 POWER INSTALLATION ENGINE FRONT MOUNTING

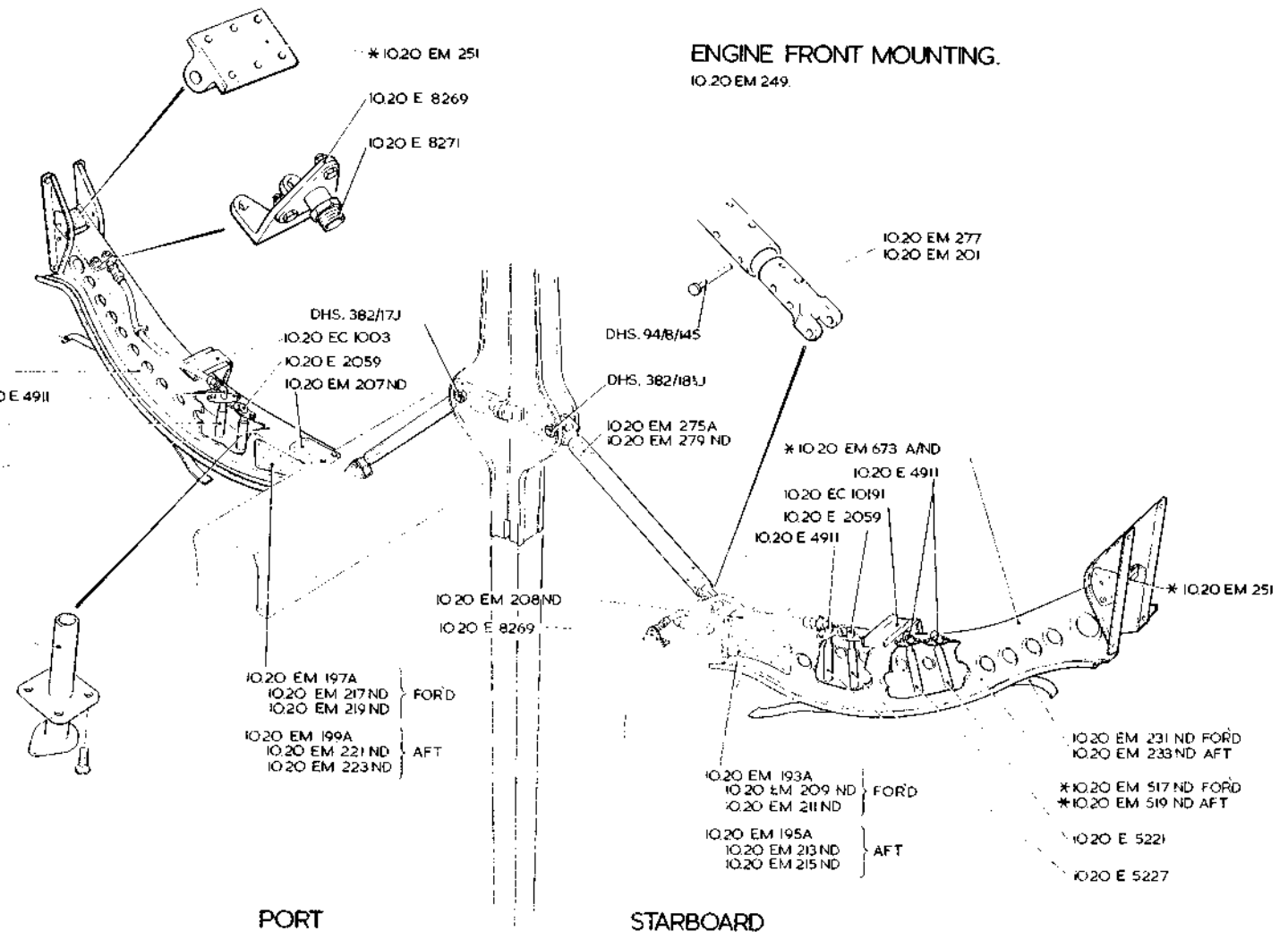

RESTRICTED