

**RADIO AND RADAR INSTALLATIONS
INSTALLATION OF I.F.F. MK. 10 AND CODER
(A.R.I.5848-F-4-Q-9)**

Ref. No.	Part No.	Description	No. off	Material Specification	Class of Store or L.M.	Place No.			
							1	2	3
		INSTALLATION OF I.F.F. Mk. 10 AND CODER (A.R.I.5848-F-4-Q-9) (Drg. Nos. 10-20 R 2561 and 10-20 R 2539)	1	—	—				
28E/1006377	AS.3180/12B	CLIP, "P," cable securing, between frame stns. 96" and 131"	7	—	C				
		Attachments for AS.3180/12B, Clip :—							
28M/10287	AGS.2001/B/1	Nut, 4 BA	1	—	C				
28S/9992522	A32/B16	Screw, 4 BA	1	—	C				
28W/9419401	SP.10/B	Washer	1	—	C				
28E/1201809	AS.3180/6B	CLIP, "P," cable securing, forward of front bulkhead	2	—	C				
		Attachments for AS.3180/6B, Clip :—							
28D/1008149	A25/2B	Bolt, 4 BA	1	—	C				
28W/9419465	SP.13/B	Washer	1	—	C				
28E/9450597	AS.3180/16C	CLIP, "P," cable securing, forward face rear pressure bulkhead	1	—	C				
		Attachments for AS.3180/16C, Clip :—							
28S/1011490	A32/C16	Screw, 2 BA	1	—	C				
28W/9419454	SP.10/C	Washer	1	—	C				
		CLIP, "P," cable securing, forward face rear pressure bulkhead, group	1	—	—				
28E/9471024	AS.5418/24	CLIP, "P,"	1	—	C				
28S/1011490	A32/C16	SCREW, 2 BA	1	—	C				
	10-20 N 15665ND	TUBING, protective, 4 1/2" long (Make from Part No. DHS.181/9, Ref. No. 26FY/6381) (Mod. 934)	1	P.V.C.	LM				
28W/9419454	SP.10/C	WASHER	1	—	C				
28E/14242	AS.5418/7	CLIP, "P," cable securing, from upper I.F.F. aerial	1	—	C				
		INSTALLATION AT GROUP "T," FORWARD OF NAVIGATOR'S PANEL, CODED "AN" (Drg. No. 10-20 R 2539)	1	—	—				
		BLOCK, terminal, coded "F," group (See sub-section "ECE")	—	—	—				
	10-20 R 2625A	CABLE, coded "DD4," assembly	1	—	ECC				
		INSTALLATION AT NAVIGATOR'S I.F.F. Mk. 10 PANEL (Drg. No. 10-20 N 20443 (Mod. 1042) and 10-20 R 2539)	1	—	—				
	10-20 R 2619A/1	CABLE, coded "F.CU-TR.CU," assembly (Mod. 507)	1	—	ECC				
	10-20 R 2623A	CABLE, coded "E.CU-CODER," assembly	1	—	ECC				
5895-00-283-2683		CONTROL-UNIT, coded "F"	1	—	P				
		Attachments for 5895-00-283-2683, Control-Unit :—							
28D/1214421	AS.4597/1B	Bolt, 4 BA	4	—	C				
28W/1200073	SP.23/B	Washer	4	—	C				

**RADIO AND RADAR INSTALLATIONS
INSTALLATION OF I.F.F. MK. 10 AND CODER
(A.R.I.5848-F-4-Q-9)**

Ref. No.	Part No.	Description	No. off	Material Specification	Class of Store or L.M.	Plate No.			
							1	2	3
	—	CONTROL UNIT AND BLANKING PLATE, GROUP	1	—	—				
5841-00-323-0226	—	CONTROL UNIT , coded "E" (Service supply and fit)	1	—	P				
	—	PLATE , blanking (Used only when control-unit is not fitted) (See sub-section "FB")	—	—	—				
	—	INSTALLATION AFT OF PILOT'S SEAT (Drg. Nos. 10-20 R 9001 (Mod. 335) and 10-20 R 2539)	1	—	—				
	AN/UG.212/U	ADAPTER , right angle, at cable connection to Receiver-Transponder	1	—	C				
16959	10-20 R 3827A	CABLE , co-axial, coded "DD3-AE.TR," assembly (Pre Mod. 1294)	1	—	C				
19243	10-20 R 4103A	CONNECTOR , co-axial, coded "DD3-AE.TR," assembly (Mod. 1294)	1	—	C				
	10-20 R 3927A	CABLE , coded: "POWER.TR," assembly (Mod. 898)	1	—	ECC				
	10-20 R 2621A	CABLE , coded: "TR-CODER," assembly	1	—	ECC				
10D/21270	—	CODING UNIT , Type 6466 (Mod. 1239) (Service supply and fit)	1	—	P	NB1			
5840-00-036-6952	—	RECEIVER-TRANSPONDER , Type RT.82/AP6 ...	1	—	P				
17476	10-20 R 9189A	TRAY , mounting, for Coding-Unit and Receiver-Transponder, assembly (Mod. 1196)	1	—	P				
		Spares for:—							
26DV/11387	12-21 R 463A	CLAMP , assembly	2	—	P	NB1			
	12-21 R 465	BLOCK , hinge	1	L.64	—	NB1			
26DV/10890	12-21 R 563	NUT , clamp (knurled)	1	—	C	NB1			
28P/9710567	SP.90/C4	PEN , split, nut retaining (SP.9/C5)	1	—	C				
26DV/8962	12 R 103	PIVOT	1	—	C	NB1			
		Attachments for 12 R 103, Pivot:—							
28P/826	SP.4Y/A16	Pin, shackle	1	—	C				
28P/1021104	SP.90/C3	Pin, split, shackle pin securing (SP.9/C4) ...	1	—	C				
8432	10-20 R 1079A	CLAMP , assembly	1	—	P	NB1			
		Spares for:—							
28M/803	AGS.120/A	NUT , wing, 1/4" BSF	1	—	C				
		Attachments for AGS.120/A, Nut:—							
28P/9527619	SP.90/C7	Pin, split (SP.9/C8)	1	—	C				
		Attachments for 10-20 R 1079A, Clamp:—							
28D/1011029	A25/1E	Bolt, 1/4" BSF	2	—	C				
28M/1011475	A27/EP	Nut, 1/4" BSF	2	—	C				
28W/9418921	SP.13/E	Washer	2	—	C				
8431	10-20 R 1375	CUP , reinforcing, a/v mounting, 18 SWG ...	4	—	C	NB1			
		Attachments for 10-20 R 1375, Cup:—							
28D/9436920	A25/1C	Bolt, 1/2 BA	4	—	C				
28M/9403520	A27/CP	Nut, 1/2 BA	4	—	C				
28W/9419402	SP.13/C	Washer	4	—	C				

**RADIO AND RADAR INSTALLATIONS
INSTALLATION OF I.F.F. MK. 10 AND CODER
(A.R.I.5848-F-4-Q-9)**

Ref. No.	Part No.	Description	No. off	Material Specification	Class of Store or L.M.	Plate No.			
							1	2	3
10A/170	—	MOUNTING , anti-vibration, Equiflex, Type 979	4	—	C				
10A/17922	—	STRIP , bonding (Mod. 117)	2	—	C	NB1			
17488	10-20 R 1377	WASHER , check, 18 SWG	4	—	C	NB1			
Attachments for 10-20 R 9189A, Tray :—									
28D/14522	A25/23E	Bolt, 1/2" BSF	4	—	C				
28M/10290	AGS.2001/E/1	Nut, 1/2" BSF	4	—	C				
28W/9419405	SP.15/E	Washer	4	—	C				
INSTALLATION AT COCKPIT ROOF, AFT OF PILOT'S SEAT (Drg. No. 10-20 R 2539)									
19794	10-20 R 2611A	CABLE , co-axial, coded "DD1-Q23," assembly	1	—	C	NB1			
19118	10-20 R 3169A	CABLE , co-axial, coded "DD2-A8," assembly	1	—	C	NB1			
10F/19511	—	RELAY , Type 6850, coded "DD" (Mod. 753)	1	—	P	NB1			
Attachments for Ref. No. 10F/19511, Relay :—									
28M/10287	AGS.2001/B/1	Nut, 4 BA	3	—	C				
28W/9419465	SP.13/B	Washer	3	—	C				
INSTALLATION AT STARBOARD NOSE FAIRING (Drg. Nos. 10-20 R 2539 and 10-20 R 3163)									
10B/20275	—	AERIAL , Type 100B (Mod. 1201)	1	—	P	NB1			
Attachments for Ref. No. 10B/20275, Aerial :—									
28D/1013172	AS.1242/5C	Bolt, 2 BA	12	—	C				
28M/10288	AGS.2001/C/1	Nut, 2 BA	12	—	C				
28W/9419402	SP.13/C	Washer	12	—	C				
19216	10-20 R 1907	Washer, sealing	1	—	C	NB1			
	10-20 R 3171A	CABLE , co-axial, coded "A8-LOWER.AE," assembly	1	—	ECC	NB1			
INSTALLATION AT REAR PRESSURE BULKHEAD, CODED "Q" (Drg. No. 10-20 R 2539)									
	—	BLOCK , terminal, coded "AE," group (See sub-section "ECE")	—	—	—				
19692	10-20 R 2609A	CABLE , co-axial, coded "Q23-UPPER.AE," assembly	1	—	C	NB1			
INSTALLATION AFT OF WING DECK PANEL (Drg. No. 10-20 R 1911)									
10B/20275	—	AERIAL , Type 100B (Mod. 1201)	1	—	P	NB1			
Attachments for Ref. No. 10B/20275, Aerial :—									
28D/1013172	AS.1242/5C	Bolt, 2 BA	12	—	C				
28M/10288	AGS.2001/C/1	Nut, 2 BA	12	—	C				
28W/9419402	SP.13/C	Washer	12	—	C				
19216	10-20 R 1907	Washer, sealing	1	—	C	NB1			
5F/9434858	—	STRAP , cable securing, 3/8" wide	QR	—	C				
5F/9138823	—	STUD , cable strap	QR	—	C				
32B/—	—	TAPE , identification, numbers and letters, use from Ref. Nos. 32B/1087 to 32B/1120 inclusive as required	QR	—	C				

**RADIO AND RADAR INSTALLATIONS
INSTALLATION OF I.F.F. MK. 10 AND CODER
(A.R.I.5848-F-4-Q-9)**

Ref. No.	Part No.	Description										No. off	Material Specification	Class of Store or L.M.	Place No.
		1	2	3	4	5	6	7	8	9	10				

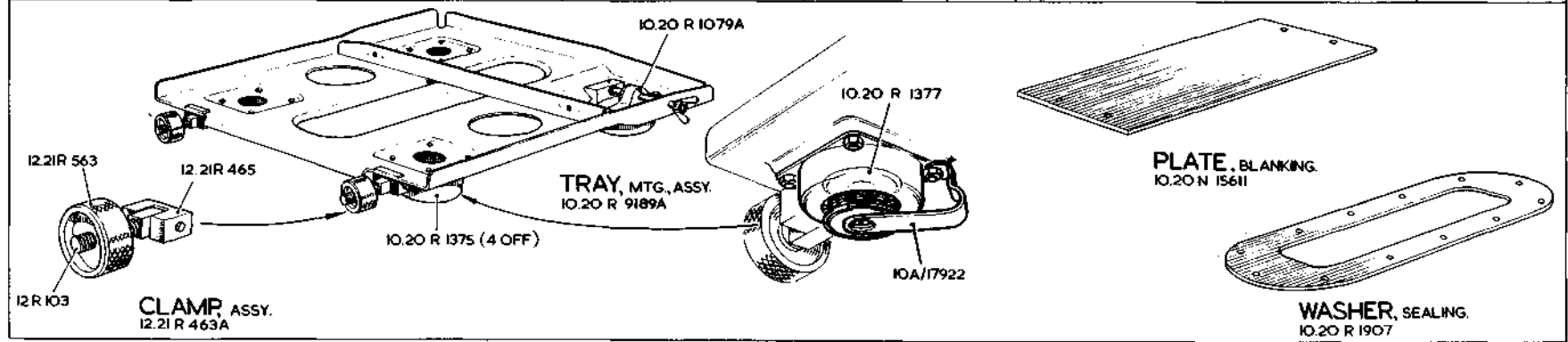
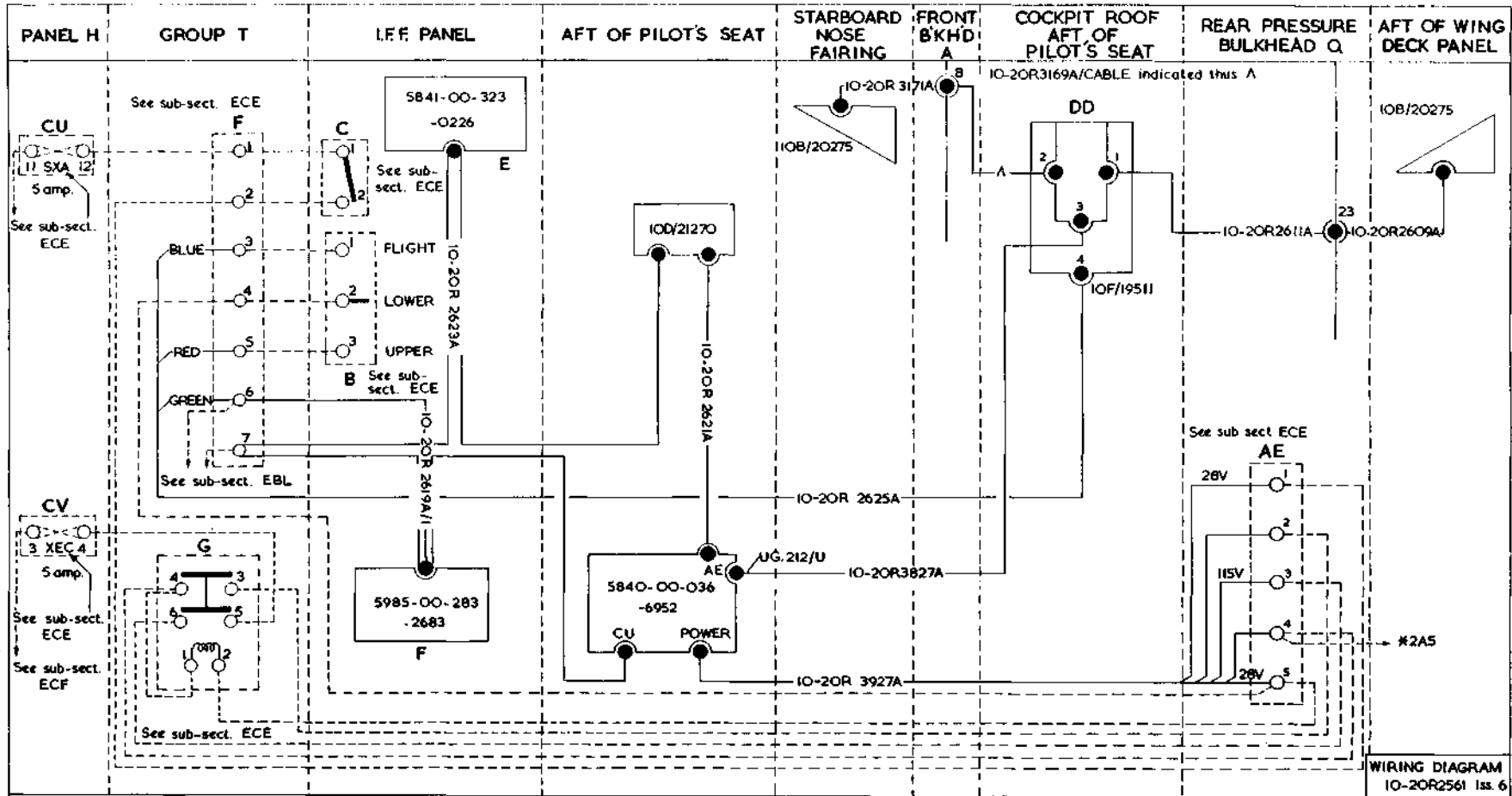

NB.1

RADIO & RADAR
INSTALLATION OF I.F.F. MK. 10
A.R.I. 5848-F-4-Q-9

RESTRICTED

NB.1
[ALL 46]



This file was downloaded
from the RTFM Library.

Link: www.scottbouch.com/rtfm

Please see site for usage terms,
and more aircraft documents.