

**RADIO AND RADAR INSTALLATIONS  
INSTALLATION OF U.H.F. RADIO AND EXTERNAL INTERCOM.  
(A.R.I.18124/1)**

| Ref. No.               | Part No.             | Description   | No. off | Material Specification | Class of Store or L.M. | Plate No. |   |   |   |
|------------------------|----------------------|---|---------|------------------------|------------------------|-----------|---|---|---|
|                        |                      |   |         |                        |                        |           | 1 | 2 | 3 |
|                        | —                    | <b>INSTALLATION OF U.H.F. RADIO AND EXTERNAL INTERCOM.</b><br>(A.R.I.18124/1) (Drg. Nos. 10-20 R 3509 and 10-20 R 3531 (Pre Mod. 181) and 10-20 R 3685 and 10-20 R 3687 (Mod. 181)<br>Spares for :— | 1       | —                      | —                      |           |   |   |   |
| 28E/1006377            | AS.3180/12B          | <b>CLIP</b> , "P." cable securing, aft of fuselage str. 118"-5<br>Attachments for AS.3180/12B, Clip :—  | 1       | —                      | C                      |           |   |   |   |
| 28S/9992522            | A32/B16              | <b>Screw</b> , 4 BA   | 1       | —                      | C                      |           |   |   |   |
|                        | 10-20 R 2689A        | <b>CLIP</b> , "P." special, cable securing in fuselage nose, assembly   | 2       | —                      | —                      | NH3       |   |   |   |
| 6381                   | 10-20 R 2687ND       | <b>CLIP</b> , bare, 20 SWG  | 1       | L.72                   | LM                     | NH3       |   |   |   |
|                        | DHS.181/9            | <b>TUBING</b> , 9 m/m i/d   | QR      | P.V.C.                 | C                      | NH3       |   |   |   |
|                        | —                    | <b>INSTALLATION IN FUSELAGE NOSE</b> (Drg. Nos. 10-20 R 3531) (Pre Mod. 181) and 10-20 R 3687 (Mod. 181)  | 1       | —                      | —                      |           |   |   |   |
|                        | —                    | <b>BLOCK</b> , terminal, coded "ABO" (See sub-section ECJ)  | —       | —                      | —                      |           |   |   |   |
|                        | 10-20 R 3447A        | <b>CABLE</b> , co-axial, coded "LOWER AE-LG," assembly  | 1       | —                      | ECC                    |           |   |   |   |
|                        | —                    | <b>INSTALLATION OF LOWER U.H.F. AERIAL</b><br>(Drg. No. 10-20 R 3333)   | 1       | —                      | —                      |           |   |   |   |
| 5985-99-932-6362<br>OR | DERVEAUX             | <b>AERIAL</b> , Type 244  | 1       | —                      | P                      | NH1       |   |   |   |
| 5985-99-911-8266       | McMICHAEL            | <b>AERIAL</b><br>Attachments for: 5985-99-932-6362 or 5985-99-911-8266, Aerial :—   | 1       | —                      | P                      | NH1       |   |   |   |
| 28D/8308               | AS.1242/3C           | <b>Bolt</b> , 2 BA  | 8       | —                      | C                      |           |   |   |   |
|                        | —                    | <b>PLATE</b> , relays mounting, coded "AAO" (See sub-section ECJ)   | —       | —                      | —                      |           |   |   |   |
|                        | —                    | <b>INSTALLATION AT STARBOARD FRONT CONSOLE PANEL, CODED "J"</b> (Drg. Nos. 10-20 R 3531) (Pre Mod. 181), 10-20 R 3687 (Mod. 181) and 10-20 N 14273)   | 1       | —                      | —                      |           |   |   |   |
| 5821-99-942-8543       | 10-20 R 9015A        | <b>CABLE</b> , coded "AF.UNIT-CU," assembly (Mod. 335)  | 1       | —                      | ECC                    |           |   |   |   |
|                        | —                    | <b>UNIT</b> , control, U.H.F., C1607/ARC.52   | 1       | —                      | P                      |           |   |   |   |
|                        | —                    | <b>INSTALLATION AT P.A.S. PANEL, CODED "AU"</b> (Drg. No. 10-20 R 3687)   | 1       | —                      | —                      |           |   |   |   |
|                        | —                    | <b>BLOCK</b> , terminal, coded "NY" (See sub-section EBZ)   | —       | —                      | —                      |           |   |   |   |
|                        | 10-20 R 2547/Mk. 134 | <b>CABLE</b> , coded "1.NY.RFH-★RFH★H.CR.7," assembly (Mod. 1154)   | 1       | —                      | ECC                    |           |   |   |   |
|                        | 10-20 R 2547/Mk. 135 | <b>CABLE</b> , coded "3.NY.RFH-RFH.H.CR.19," assembly (Mod. 1154)   | 1       | —                      | ECC                    |           |   |   |   |
|                        | —                    | <b>SWITCH</b> , target flares, coded "Q" (See sub-section EBZ)  | —       | —                      | —                      |           |   |   |   |



**RADIO AND RADAR INSTALLATIONS  
INSTALLATION OF U.H.F. RADIO AND EXTERNAL INTERCOM.  
(A.R.I.18124/1)**

| Ref. No.         | Part No.             | Description   | No. off | Material Specification | Class of Store or L.M. | Plate No. |   |   |   |
|------------------|----------------------|---|---------|------------------------|------------------------|-----------|---|---|---|
|                  |                      |   |         |                        |                        |           | 1 | 2 | 3 |
|                  | 10-20 R 9011A        | <b>CABLE</b> , coded "AF. UNIT," assembly (Mod. 335)  | 1       | —                      | ECC                    |           |   |   |   |
|                  | 10-20 R 8093A        | <b>CABLE</b> , coded "H," assembly (Mod. 1053) ...  | 1       | —                      | ECC                    |           |   |   |   |
|                  | 10-20 R 2547/Mk. 4   | <b>CABLE</b> , coded "1A.AF-H.DB4," assembly ...  | 1       | —                      | ECC                    |           |   |   |   |
|                  | 10-20 R 2547/Mk. 31  | <b>CABLE</b> , coded "9E.AF-H.CX17," assembly ...<br>(Mod. 181, Pre Mod. 803)   | 1       | —                      | ECC                    |           |   |   |   |
|                  | 10-20 R 2547/Mk. 128 | <b>CABLE</b> , "9E.AF-H.A.CX17," assembly (Mods. 803 and 181)   | 1       | —                      | ECC                    |           |   |   |   |
|                  | 10-20 R 2547/Mk. 32  | <b>CABLE</b> , coded "5E.AF-H.DB9," assembly ...<br>(Mod. 181)  | 1       | —                      | ECC                    |           |   |   |   |
|                  | 10-20 R 2547/Mk. 108 | <b>CABLE</b> , coded "1CM.H-JJ.1," assembly ...   | 1       | —                      | ECC                    |           |   |   |   |
|                  | 10-20 R 2547/Mk. 119 | <b>CABLE</b> , coded, "8A.AF-H.CM2," assembly ...   | 1       | —                      | ECC                    |           |   |   |   |
|                  | 10-20 R 2547/Mk. 120 | <b>CABLE</b> , coded "5CX.H-AF.A11," assembly ...<br>(Pre Mod. 803)   | 1       | —                      | ECC                    |           |   |   |   |
|                  | 10-20 R 2547/Mk. 129 | <b>CABLE</b> , coded, "11A.AF-H.A.CX5," assembly<br>(Mod. 803)  | 1       | —                      | ECC                    |           |   |   |   |
|                  | —                    | <b>RESISTOR</b> , coded "DV" (See sub-section NK) ...   | —       | —                      | —                      |           |   |   |   |
|                  | —                    | <b>SWITCHES</b> , coded "BC" and "DN" (See sub-section EBZ)   | —       | —                      | —                      |           |   |   |   |
|                  | —                    | <b>SWITCH</b> , coded "DU" (See sub-section NK) ...   | —       | —                      | —                      |           |   |   |   |
|                  | —                    | <b>INSTALLATION AT GROUP CODED "S" COCKPIT WALL, STARBOARD</b>  | 1       | —                      | —                      |           |   |   |   |
|                  | —                    | <b>BLOCK</b> , fuse, coded "S-A" (See sub-section EBZ)  | —       | —                      | —                      |           |   |   |   |
|                  | —                    | <b>INSTALLATION IN COCKPIT AFT OF PILOT'S SEAT AND AT PANEL CODED "AF" (Drg. Nos. 10-20 R 3687 (Mod. 181) and 10-20 R 9001)</b> | 1       | —                      | —                      |           |   |   |   |
| 5935-00-199-1806 | AN/UG/27A/U          | <b>ADAPTER</b> , right angle, ac aerial relay coded "JH"  | 1       | —                      | C                      |           |   |   |   |
|                  | —                    | <b>BLOCK</b> , terminal, coded "F" at group coded "CX"<br>(See sub-section NK)  | —       | —                      | —                      |           |   |   |   |
|                  | —                    | <b>BLOCK</b> , terminal coded "J-J" group ...   | 1       | —                      | —                      |           |   |   |   |
|                  | DHS.456/2            | <b>BLOCK</b> , terminal, 2-way, assembly (For breakdown see DHS data sheet)   | 1       | —                      | —                      |           |   |   |   |
| 5X/3272          | PLESSEY CZ.26799     | <b>COVER</b> ...  | 1       | —                      | C                      |           |   |   |   |
| 5X/9450403       | PLESSEY Z.28426      | <b>PILLAR</b> , fixing ...  | 2       | —                      | C                      |           |   |   |   |
|                  | —                    | <b>BOX</b> , junction, Type 154, coded "AY" (See sub-section NC)  | —       | —                      | —                      |           |   |   |   |

**RADIO AND RADAR INSTALLATIONS**  
**INSTALLATION OF U.H.F. RADIO AND EXTERNAL INTERCOM.**  
(A.R.I.18124/1)

| Ref. No.                   | Part No.              | Description  |   |   |   |   |   |   |   |   |    | No. off | Material Specification | Class of Store or L.M. | Place No. |
|----------------------------|-----------------------|--|---|---|---|---|---|---|---|---|----|---------|------------------------|------------------------|-----------|
|                            |                       | 1  | 2 | 3 | 4 | 5 | 6 | 7 | 8 | 9 | 10 |         |                        |                        |           |
| 17450                      | 10-20 F 8427A         | <b>BRACKET</b> , U.H.F. radio and M.R.G. test point, at equipment deck, coded "AAU," assembly (Mod. 1006)  |   |   |   |   |   |   |   |   |    | 1       | —                      | C                      | NH4       |
|                            | 10-20 F 3873          | <b>LABEL</b> , "M.R.G. TEST POINTS U.H.F.," 20 SWG   |   |   |   |   |   |   |   |   |    | 1       | L.72                   | LM                     | NH4       |
|                            | 10-20 F 3875          | <b>LABEL</b> , "No. 1 M.R.G. No. 2," 20 SWG ...  |   |   |   |   |   |   |   |   |    | 1       | L.72                   | LM                     | NH4       |
| 20295                      | 10-20 F 8541A         | <b>BRACKET</b> , U.H.F. radio, M.R.G. and auto-throttle test point at equipment deck, coded "AAU," assembly (Mod. 1428)<br>Spares for :—                     |   |   |   |   |   |   |   |   |    | 1       | —                      | C                      | NH4       |
|                            | 10-20 F 8479          | <b>LABEL</b> , "M.R.G. U.H.F. AUTO-THROTTLE TEST POINTS," 20 SWG (Ref. Drg. No. 10-20 F 8539A)<br>Attachments for 10-20 F 8427A or 10-20 F 8541A, Bracket :— |   |   |   |   |   |   |   |   |    | 1       | L.72                   | LM                     | NH4       |
| 28D/1007979<br>28W/9419465 | AS.1246/1B<br>SP.13/B | <b>Bolt</b> , 4 BA ... ..  |   |   |   |   |   |   |   |   |    | 7       | —                      | C                      |           |
|                            |                       | <b>Washer</b> ... ..   |   |   |   |   |   |   |   |   |    | 7       | —                      | C                      |           |
|                            | 10-20 R 3445A         | <b>CABLE</b> , co-axial, coded "Q37-REL.JHC," assembly   |   |   |   |   |   |   |   |   |    | 1       | —                      | ECC                    |           |
|                            | 10-20 R 9007A         | <b>CABLE</b> , coded "AF.UNIT," assembly (Mod. 335)  |   |   |   |   |   |   |   |   |    | 1       | —                      | ECC                    |           |
|                            | 10-20 R 9009A         | <b>CABLE</b> , coded "AF.UNIT," assembly (Mod. 335)  |   |   |   |   |   |   |   |   |    | 1       | —                      | ECC                    |           |
| 15837                      | 10-20 R 3309A         | <b>CABLE</b> , coded "PILOT-AF," assembly (Mod. 439)   |   |   |   |   |   |   |   |   |    | 1       | —                      | C                      |           |
|                            | 10-20 R 9013A         | <b>CABLE</b> , coded "TR-AF.UNIT," assembly (Mod. 335)   |   |   |   |   |   |   |   |   |    | 1       | —                      | ECC                    |           |
|                            | 10-20 R 9017A         | <b>CABLE</b> , coded "1.AAU-AF.UHF.TEST," assembly (Mod. 335)  |   |   |   |   |   |   |   |   |    | 1       | —                      | ECC                    |           |
|                            | 10-20 R 2547/Mk. 109  | <b>CABLE</b> , coded "13AE.Q-JJ2," assembly ...  |   |   |   |   |   |   |   |   |    | 1       | —                      | ECC                    |           |
|                            | 10-20 R 2547/Mk. 21   | <b>CABLE</b> , coded "17AE.Q-AY.CREW.M-," assembly   |   |   |   |   |   |   |   |   |    | 1       | —                      | ECC                    |           |
|                            | 10-20 R 2547/Mk. 24   | <b>CABLE</b> , coded "14AE.Q-AY.T-," assembly ...  |   |   |   |   |   |   |   |   |    | 1       | —                      | ECC                    |           |
|                            | 10-20 R 2547/Mk. 105  | <b>CABLE</b> , coded "9B.AF-Q.AA6," assembly ...   |   |   |   |   |   |   |   |   |    | 1       | —                      | ECC                    |           |
| 5821-99-942-8544           | —                     | <b>MOUNTING</b> , tray, Type MT.1477/ARC.52 for transmitter-receiver<br>Attachments for 5821-99-942-8544, Mounting :—  |   |   |   |   |   |   |   |   |    | 1       | —                      | P                      |           |
|                            | 10-20 R 3373          | <b>Block, packing</b> : ... ..   |   |   |   |   |   |   |   |   |    | 2       | LFS.21,<br>23 or 26    | LM                     |           |
| 28D/9133012                | A25/3C                | <b>Bolt</b> , 2 BA, front mounting ... ..  |   |   |   |   |   |   |   |   |    | 4       | —                      | C                      |           |
| 28D/7002428                | A25/6C                | <b>Bolt</b> , 2 BA, rear mounting ... ..   |   |   |   |   |   |   |   |   |    | 4       | —                      | C                      |           |
| 28D/9140648                | A25/19C               | <b>Bolt</b> , 2 BA, through packing blocks ... ..  |   |   |   |   |   |   |   |   |    | 8       | —                      | C                      |           |
| 28M/10288                  | AGS.2001/C/1          | <b>Nut</b> , 2 BA ... ..   |   |   |   |   |   |   |   |   |    | 8       | —                      | C                      |           |
| 28W/9419402                | SP.13/C               | <b>Washer</b> ... ..   |   |   |   |   |   |   |   |   |    | 16      | —                      | C                      |           |
|                            | 10-20 R 9357A/ND      | <b>PANEL</b> , coded "AF," c/w cables, assembly (Mod. 183, Pre Mod. 1290)  |   |   |   |   |   |   |   |   |    | 1       | —                      | —                      |           |
|                            | 10-20 R 9351A/ND      | <b>PANEL</b> , coded "AF," c/w cables, assembly (Mod. 1290)  |   |   |   |   |   |   |   |   |    | 1       | —                      | —                      |           |
|                            | 10-20 R 2547/Mk. 9    | <b>CABLE</b> , coded "15B.AF-AY.PIL.M-," assembly  |   |   |   |   |   |   |   |   |    | 1       | —                      | ECC                    |           |
|                            | 10-20 R 2547/Mk. 10   | <b>CABLE</b> , coded "18B.AF-AY.PIL.M+," assembly  |   |   |   |   |   |   |   |   |    | 1       | —                      | ECC                    |           |
|                            | 10-20 R 2547/Mk. 18   | <b>CABLE</b> , coded "6A.AF-AY.P to T+," assembly  |   |   |   |   |   |   |   |   |    | 1       | —                      | ECC                    |           |
|                            | 10-20 R 2547/Mk. 19   | <b>CABLE</b> , coded "16A.AF-AY.TX.M+," assembly   |   |   |   |   |   |   |   |   |    | 1       | —                      | ECC                    |           |

**RADIO AND RADAR INSTALLATIONS**  
**INSTALLATION OF U.H.F. RADIO AND EXTERNAL INTERCOM.**  
**(A.R.I.18124/1)**

| Ref. No.    | Part No.                     | Description   | No. off | Material Specification | Class of Store or L.M. | Place No. |   |   |   |
|-------------|------------------------------|---|---------|------------------------|------------------------|-----------|---|---|---|
|             |                              |   |         |                        |                        |           | 1 | 2 | 3 |
|             | 10-20 R 2547/Mk. 20          | <b>CABLE</b> , coded " 19A.AF-AY.TX.M-," assembly ...                                   | 1       | —                      | ECC                    |           |   |   |   |
|             | 10-20 R 2547/Mk. 25          | <b>CABLE</b> , coded " 13A.AF-AY.REC.1+," assembly                                      | 1       | —                      | ECC                    |           |   |   |   |
|             | 10-20 R 2547/Mk. 80          | <b>CABLE</b> , coded " 12E.AF-AY.PIL.M+," assembly ...                                  | 1       | —                      | ECC                    |           |   |   |   |
|             | 10-20 R 2547/Mk. 86          | <b>CABLE</b> , coded " 14E.AF-AY.PIL.M-," assembly ...                                  | 1       | —                      | ECC                    |           |   |   |   |
|             | 10-20 R 2547/Mk. 110         | <b>CABLE</b> , coded " 6B.AF-AY.T+," assembly ...                                       | 1       | —                      | ECC                    |           |   |   |   |
|             | 10-20 R 2547/Mk. 115         | <b>CABLE</b> , coded " 3B.AF-AY.T-," assembly ...                                       | 1       | —                      | ECC                    |           |   |   |   |
|             | 10-20 R 9355A                | <b>PANEL</b> , relay, coded " AF," complete (Mod. 1183, Pre Mod. 1290)<br>Spares for :— | 1       | —                      | —                      |           |   |   |   |
|             | 10-20 R 9349A                | <b>PANEL</b> , relay, coded " AF," complete (Mod. 1290)                                 | 1       | —                      | —                      |           |   |   |   |
|             | —                            | <b>BLOCKS</b> , terminal, coded " A " and " E," group                                   | 1       | —                      | —                      |           |   |   |   |
|             | DHS.456/20                   | <b>BLOCK</b> , terminal, 20-way, assembly ...<br>(For breakdown see DHS data sheet)     | 2       | —                      | —                      |           |   |   |   |
| 5X/9149643  | PLESSEY CZ.25111             | <b>COVER</b> (5940-99-914-9643) ...   | 2       | —                      | C                      |           |   |   |   |
| 5X/9550403  | PLESSEY Z.28426              | <b>PILLAR</b> , 4 BA (Pre Mod. 1290) ...<br>(5340-99-945-0403)                          | 4       | —                      | C                      |           |   |   |   |
| 7657        | DHS.870/5                    | <b>PILLAR</b> , fixing, 4 BA (Mod. 1290) ...  | 4       | —                      | C                      |           |   |   |   |
| 26DV/12296  | DHS.489/5                    | <b>SPACER</b> , at block, coded " E " (Mod. 1290)                                       | 2       | —                      | C                      |           |   |   |   |
|             | DHS.456/20                   | <b>BLOCK</b> , terminal, 20-way, assembly (For breakdown see DHS data sheet)            | 1       | —                      | —                      |           |   |   |   |
| 5X/9149643  | PLESSEY CZ.25111             | <b>COVER</b> (5940-99-914-9643) ...   | 1       | —                      | C                      |           |   |   |   |
| 5X/6172     | PLESSEY Z.50212              | <b>LINK</b> , commoning, 4-way, between terminals Nos. 1 and 4                          | 1       | —                      | C                      |           |   |   |   |
| 7657        | DHS.870/5                    | <b>PILLAR</b> , fixing, 4 BA (Pre Mod. 1290) ...  | 2       | —                      | C                      |           |   |   |   |
| 5X/9450403  | PLESSEY Z.28426              | <b>PILLAR</b> , fixing, 4 BA (Mod. 1290) ...<br>(5340-99-945-0403)                      | 2       | —                      | C                      |           |   |   |   |
| 26DV/12296  | DHS.489/5                    | <b>SPACER</b> (Pre Mod. 1290) ...   | 2       | —                      | C                      |           |   |   |   |
| 15786       | 10-20 R 3301A                | <b>BOX</b> , relay, wired, coded " C," assembly<br>Spares for :—                        | 1       | —                      | P                      |           |   |   |   |
|             | 10-20 R 2931A                | <b>BONDING</b> , assembly ...   | 1       | —                      | —                      | NH3       |   |   |   |
|             | 10-20 R 1827ND               | <b>STRIP</b> , bonding, 1/4" wide x 22 SWG ...  | 1       | BS.265                 | LM                     | NH3       |   |   |   |
|             | 10-20 R 1831ND               | <b>STRIP</b> , bonding, 1/4" wide x 22 SWG ...  | 2       | BS.265                 | LM                     | NH3       |   |   |   |
|             | 10-20 R 2941ND               | <b>STRIP</b> , bonding, 1/4" wide x 22 SWG ...  | 1       | BS.265                 | LM                     | NH3       |   |   |   |
|             | 10-20 R 625A                 | <b>BOX</b> , relay, bare, assembly ...  | 1       | —                      | —                      | NH3       |   |   |   |
| 8427        | 10-20 R 627ND                | <b>LID</b> , box, fibreglass ...  | 1       | —                      | C                      | NH3       |   |   |   |
|             | —                            | Attachments for 10-20 R 627ND, Lid :—   |         |                        |                        |           |   |   |   |
| 28S/1200066 | A33/B20                      | Screw; 4 BA ...   | 2       | —                      | C                      |           |   |   |   |
|             | 10-20 R 3301A/CABLES         | <b>CABLES</b> , link (Make from Ref. No. 5E/9100180)                                    | QR      | —                      | LM                     |           |   |   |   |
|             | 10-20 R 639A                 | <b>LEAD</b> , bonding, assembly, 3"0 long ...<br>Attachments for 10-20 R 639A, Lead :—  | 1       | —                      | —                      | NH3       |   |   |   |
| 28M/10286   | AGS.2001/A/1                 | Nut, 6 BA ...   | 2       | —                      | C                      |           |   |   |   |
| 28S/1006948 | A32/A12                      | Screw, 6 BA ...   | 2       | —                      | C                      |           |   |   |   |
| 28W/9419446 | SP.10/A                      | Washer ...  | 2       | —                      | C                      |           |   |   |   |
| 10H/0560200 | —                            | <b>PLUG</b> , 25 pole (5935-99-056-0200) ...  | 1       | —                      | C                      | NH3       |   |   |   |
|             | STANDARD TELEPHONES & CABLES | <b>RELAY</b> , STC Type SM5A/N.25 ...<br>(5945-99-053-0453)                             | 6       | —                      | P                      |           |   |   |   |
| 10F/0530453 | —                            | Attachments for Ref. No. 10F/0530453, Relay :—  |         |                        |                        |           |   |   |   |
| 28M/10286   | AGS.2001/A/1                 | Nut, 6 BA (Replacing nuts supplied with relay)  | 2       | —                      | C                      |           |   |   |   |

**RADIO AND RADAR INSTALLATIONS**  
**INSTALLATION OF U.H.F. RADIO AND EXTERNAL INTERCOM.**  
**(A.R.I.18124/1)**

| Ref. No.         | Part No.                   | Description  | No. off | Material Specification | Class of Store or L.M. | Plate No. |   |   |   |
|------------------|----------------------------|--|---------|------------------------|------------------------|-----------|---|---|---|
|                  |                            |  |         |                        |                        |           | 1 | 2 | 3 |
| 5X/3146          | PLESSEY Z.49397            | <b>SLEEVE</b> , adapter (Solder into relay pins) ...   | 11      | —                      | C                      |           |   |   |   |
| 5X/1005131       | PLESSEY Z.49428            | <b>SLEEVE</b> , adapter (Solder into relay pins) ...<br>(5935-99-100-5131)                       | 30      | —                      | C                      |           |   |   |   |
| 5K/—<br>13100    | P1 x 3/8"<br>10-20 R 2933A | <b>SLEEVE</b> , "Helvyn" ...   | 41      | —                      | C                      |           |   |   |   |
|                  |                            | <b>TRAY</b> , relay, assembly ...  | 1       | —                      | C                      | NH3       |   |   |   |
|                  |                            | Attachments for 10-20 R 2933A, Tray :—   |         |                        |                        |           |   |   |   |
| 28D/1214866      | AS.1246/4B                 | Bolt, 4 BA: ...  | 4       | —                      | C                      |           |   |   |   |
| 5K/—             | SP.95/A4                   | Grommet (Alternative DHS.1790/A4) ...  | 4       | —                      | C                      |           |   |   |   |
| 28W/9419474      | SP.15/B                    | Washer ...   | 4       | —                      | C                      |           |   |   |   |
|                  |                            | Attachments for 10-20 R 3301A, Box :—  |         |                        |                        |           |   |   |   |
| 28S/1008327      | A32/B14                    | Screw, 4 BA: ...   | 4       | —                      | C                      |           |   |   |   |
| 28W/9419465      | SP.13/B                    | Washer ...   | 8       | —                      | C                      |           |   |   |   |
|                  | 10-20 R 3303A              | <b>CABLE</b> , coded "CAF," assembly ...   | 1       | —                      | ECC                    |           |   |   |   |
|                  | 10-20 R 9355A/CABLES       | <b>CABLES</b> , link (Mod. 1183, Pre Mod. 1290) ...  | QR      | —                      | ECC                    |           |   |   |   |
|                  | 10-20 R 9349A/CABLES       | <b>CABLES</b> , link (Mod. 1290) ...   | QR      | —                      | ECC                    |           |   |   |   |
| 28E/9000883      | AS.3180/9B                 | <b>CLIP</b> , "P" (Mod. 181) ...   | 1       | —                      | C                      |           |   |   |   |
|                  | 10-20 R 3541               | <b>CLIP</b> , "P" special, bonding, 22 SWG (Mod. 181)  | 1       | BS.265                 | LM                     | NH3       |   |   |   |
|                  |                            | Attachments for AS.3180/9B or 10-20 R 3541,<br>Clip :—   |         |                        |                        |           |   |   |   |
| 28D/8337         | AS.1248/1B                 | Bolt, 4 BA ...   | 1       | —                      | C                      |           |   |   |   |
|                  | 19688                      | <b>MOUNTING</b> , resistor, assembly (Pre Mod. 1290)   | 1       | —                      | C                      | NH3       |   |   |   |
|                  | 10-20 R 3351A              | <b>BASE</b> , resistor mounting ...  | 1       | LFS.26                 | —                      | NH3       |   |   |   |
|                  | 10-20 R 3349               | <b>RESISTOR</b> , 200 ohms, Type 5BD, 1/2 watt<br>(spots. red, black, brown)                     | 2       | Carbon                 | —                      | NH3       |   |   |   |
| 5905-99-946-4924 | ERIE                       | <b>RESISTOR</b> , 10,000 ohms, Type 5BD, 1/2 watt<br>(spots brown, black, orange)                | 1       | Carbon                 | —                      | NH3       |   |   |   |
| 5905-99-999-0922 | ERIE                       | <b>SLEEVE</b> , binding ...  | 4       | —                      | C                      |           |   |   |   |
| 5K/9107065       | —                          | <b>SLEEVE</b> , binding ...  | 4       | —                      | C                      |           |   |   |   |
|                  | —                          | <b>SLEEVE</b> , "silicone," white, 1 m/m ...   | QR      | Q.166                  | —                      |           |   |   |   |
| 5X/9400061       | PLESSEY Z.19924            | <b>TAG</b> , termination ...   | 2       | —                      | C                      | NH3       |   |   |   |
|                  | 10-20 R 2985A              | <b>PANEL</b> , base, assembly ...  | 1       | —                      | —                      | NH3       |   |   |   |
|                  |                            | Spares for :—  |         |                        |                        |           |   |   |   |
| 32C/600          | —                          | <b>SECTION</b> , rubber, Burley, fitted at edge of<br>lightening holes, 1/2" dia. x 0"05<br>slot | QR      | —                      | C                      |           |   |   |   |
|                  | 19242                      | <b>PANEL</b> , resistor, assembly (Mod. 1290) ...  | 1       | —                      | C                      | NH3       |   |   |   |
|                  | 10-20 R 2947A              | <b>RELAY</b> , external Intercom, coded "D.AF,"<br>wired, assembly (Mod. 181)                    | 1       | —                      | —                      |           |   |   |   |
|                  |                            | Spares for :—  |         |                        |                        |           |   |   |   |
|                  | 10-20 R 2947A/CABLES       | <b>CABLES</b> ...  | QR      | —                      | ECC                    |           |   |   |   |
| 5945-99-011-9145 | ERICSSON                   | <b>RELAY</b> , Type 2 ...  | 1       | —                      | —                      |           |   |   |   |
|                  | N.22364/AD.1               | <b>RELAY</b> , Navigator's Telebrief, coded "G.AF,"<br>wired, assembly                           | 1       | —                      | P                      |           |   |   |   |
|                  | 15785                      | 10-20 R 3305A  |         |                        |                        |           |   |   |   |
|                  |                            | Spares for :—  |         |                        |                        |           |   |   |   |
|                  | 10-20 R 3305A/CABLES       | <b>CABLES</b> ...  | QR      | —                      | ECC                    |           |   |   |   |
| 5945-99-011-9145 | ERICSSON                   | <b>RELAY</b> , Type 2 ...  | 1       | —                      | —                      |           |   |   |   |
|                  | N.22364/AD.1               |  |         |                        |                        |           |   |   |   |

**RADIO AND RADAR INSTALLATIONS**  
**INSTALLATION OF U.H.F. RADIO AND EXTERNAL INTERCOM.**  
**(A.R.I.18124/1)**

| Ref. No.         | Part No.   | Description  | No. off | Material Specification | Class of Store or L.M. | Place No. |   |   |   |
|------------------|--|--|---------|------------------------|------------------------|-----------|---|---|---|
|                  |  |  |         |                        |                        |           | 1 | 2 | 3 |
|                  | 10-20 R 3249A                                    | <b>RELAY</b> , Pilot's Telebrief, coded " F.A.F. " wired, assembly<br>Spares for :—  | 1       | —                      |                        |           |   |   |   |
| 5945-99-011-9145 | 10-20 R 3249A/CABLES<br>ERICSSON<br>N.22364/AD.1 | <b>CABLES</b> ... ..   | QR      | —                      | ECC                    |           |   |   |   |
|                  |  | <b>RELAY</b> , Type 2 ... ..<br>Attachments for 10-20 R 2947A, 10-20 R 3305A or 10-20 R 3249A, Relay :—                      | 1       | —                      |                        |           |   |   |   |
| 28M/10327        | AGS.2002/B/1                                     | Nut, 4 BA ... ..   | 2       | —                      | C                      |           |   |   |   |
| 28S/1012450      | A32/B10  | Screw, 4 BA ... ..   | 2       | —                      | C                      |           |   |   |   |
| 28W/9419465      | SP.13/B  | Washer ... ..  | 2       | —                      | C                      |           |   |   |   |
| 5195             | DHS.849  | <b>SCREW</b> , terminal, at terminals Nos. 1, 2, 3 and 4 on t/b " B " (Mod. 181)   | 4       | —                      | C                      |           |   |   |   |
| 5F/9434858       | HELLERMANN<br>HV.3254                            | <b>STRAP</b> , cable fastening, $\frac{1}{16}$ " wide ... ..   | QR      | —                      | C                      |           |   |   |   |
| 5F/9138823       | HELLERMANN<br>NY.3255                            | <b>STUD</b> , for cable strap ... ..   | QR      | —                      | C                      |           |   |   |   |
| 32B/—            | —  | <b>TAPE</b> , identification, numbers and letters, use from Ref. Nos. 32B/1087 to 32B/1120 inclusive, as required            | QR      | —                      | C                      |           |   |   |   |
| 26DV/4968        | DHS.457  | <b>TERMINAL</b> , bonding, earth, assembly ... ..<br>Attachments for DHS.457, Terminal :—                                    | 1       | —                      | C                      |           |   |   |   |
| 28M/10287        | AGS.2001/B/1                                     | Nut, 4 BA ... ..   | 2       | —                      | C                      |           |   |   |   |
| 28S/9435716      | A33/B12  | Screw, 4 BA ... ..   | 2       | —                      | C                      |           |   |   |   |
| 26DV/10901       | DHS.458  | <b>WASHER</b> , corrosion ... ..<br>Attachments for 10-20 R 3307A, 10-20 R 9355A or 10-20 R 9349A, Panel :—                  | 1       | —                      | C                      |           |   |   |   |
| 28D/9137409      | AS.1246/2C                                       | Bolt, 2 BA ... ..  | 5       | —                      | C                      |           |   |   |   |
| 28D/9140203      | AS.1246/3C                                       | Bolt, 2 BA ... ..  | 1       | —                      | C                      |           |   |   |   |
| 28W/9419402      | SP.13/C  | Washer ... ..  | 6       | —                      | C                      |           |   |   |   |
|                  | 01-20 R 3321A                                    | <b>RELAY</b> , U.H.F. aerial, coded " JH.," assembly ...   | 1       | —                      |                        |           |   |   |   |
| 10F/18374        | 10-20 R 3321A/CABLES                             | <b>CABLES</b> (Supplied with relay) ... ..   | QR      | —                      | ECC                    |           |   |   |   |
|                  |  | <b>RELAY</b> , magnetic, Type 1741 ... ..<br>Attachments for 10-20 R 3321A, Relay :—   | 1       | —                      | P                      |           |   |   |   |
| 28D/1214870      | AS.1246/8B                                       | Bolt, 4 BA ... ..  | 2       | —                      | C                      |           |   |   |   |
| 28W/9419465      | SP.13/B  | Washer ... ..  | 2       | —                      | C                      |           |   |   |   |
| 5821-99-942-8542 | —  | <b>TRANSMITTER-RECEIVER</b> , Type MT.1477/ARC.52<br><b>UNITS</b> , audio frequency and radio frequency (See sub-section NA) | 1       | —                      | P                      |           |   |   |   |
| 5310-99-914-5767 | PLESSEY 2CZ.139599                               | <b>WASHER</b> , packing, panel, at AAU.5, test point bracket (Mod. 1101)   | 1       | —                      | C                      |           |   |   |   |
|                  | —  | <b>INSTALLATION AT REAR PRESSURE BULK-HEAD CODED " Q " (Drg. Nos. 10-20 R 3687 (Mod. 181) and 10-20 N 10635)</b>             | 1       | —                      | —                      |           |   |   |   |
| 5935-99-526-0237 | AN/UG/701/U                                      | <b>ADAPTER</b> , bulkhead, coded " Q15 " and " Q16 "   | 2       | —                      | C                      |           |   |   |   |

**RADIO AND RADAR INSTALLATIONS  
INSTALLATION OF U.H.F. RADIO AND EXTERNAL INTERCOM.  
(A.R.I.18124/1)**

| Ref. No.   | Part No.             | Description   | No. off |   |   |   |   |   |   |   |   |    | Material Specification | Class of Store or L.M. | Plate No. |
|------------|----------------------|---|---------|---|---|---|---|---|---|---|---|----|------------------------|------------------------|-----------|
|            |                      |   | 1       | 2 | 3 | 4 | 5 | 6 | 7 | 8 | 9 | 10 |                        |                        |           |
| 10H/19610  | —                    | <b>ADAPTER</b> , double ended socket, upper H.H.F. aerial, coded "Q37"                          | 1       |   |   |   |   |   |   |   |   |    | —                      | C                      |           |
|            | —                    | <b>BLOCK</b> , terminal, coded "AA" group   | 1       |   |   |   |   |   |   |   |   |    | —                      | —                      |           |
|            | DHS.456/20           | <b>BLOCK</b> , terminal, 20-way, assembly (For breakdown see DHS data sheet)                    | 1       |   |   |   |   |   |   |   |   |    | —                      | —                      |           |
| 5X/9149643 | PLESSEY CZ.25111     | <b>COVER</b> , terminal block   | 1       |   |   |   |   |   |   |   |   |    | —                      | C                      |           |
| 12732      | 10-20 N 8085         | <b>PILLAR</b> , fixing  | 2       |   |   |   |   |   |   |   |   |    | —                      | C                      |           |
| 5195       | DHS.849              | <b>SCREW</b> , terminal (Fit at terminal No. 7)   | 1       |   |   |   |   |   |   |   |   |    | —                      | C                      |           |
|            | —                    | <b>BLOCK</b> , terminal, coded "AE" (See sub-section EBZ)                                       | —       |   |   |   |   |   |   |   |   |    | —                      | —                      |           |
|            | 10-20 R 2547/Mk. 107 | <b>CABLE</b> , coded "7AA.Q-Q.AE19," assembly   | 1       |   |   |   |   |   |   |   |   |    | —                      | ECC                    |           |
| 15838      | 10-20 R 3313A        | <b>CABLE</b> , navigator's intercom., coded "NAV-QAA," assembly                                 | 1       |   |   |   |   |   |   |   |   |    | —                      | P                      |           |
|            | —                    | <b>INSTALLATION IN PORT AND STARBOARD WINGS AND AT WING DECK PANELS</b> (Drg. No. 10-20 R 3555) | 1       |   |   |   |   |   |   |   |   |    | —                      | —                      |           |
|            | —                    | <b>ADAPTER</b> , double-ended, aerial cables at leading edge, Port wing (See sub-section NJ)    | —       |   |   |   |   |   |   |   |   |    | —                      | —                      |           |
|            | —                    | <b>BLOCK</b> , terminal, coded "G" on Port wing deck panel coded "FA" (See sub-section EBZ)     | —       |   |   |   |   |   |   |   |   |    | —                      | —                      |           |
|            | 10-20 R 3933A/ND     | <b>CABLES</b> , Port, group (Mods. 898 and 181)   | 1       |   |   |   |   |   |   |   |   |    | —                      | —                      |           |
|            | 10-20 R 3923A        | <b>CABLE</b> , coded "JW-FA," assembly (Mods. 898 and 181)                                      | 1       |   |   |   |   |   |   |   |   |    | —                      | ECC                    |           |
|            | 10-20 R 2547/Mk. 34  | <b>CABLE</b> , coded "17G.FA.T-T-TW.A8," assembly   | 1       |   |   |   |   |   |   |   |   |    | —                      | ECC                    |           |
|            | 10-20 R 2547/Mk. 35  | <b>CABLE</b> , coded "18G.FA.T+T-TW.A7," assembly   | 1       |   |   |   |   |   |   |   |   |    | —                      | ECC                    |           |
|            | 10-20 R 2547/Mk. 38  | <b>CABLE</b> , coded "13G.FA-TW.A2," assembly   | 1       |   |   |   |   |   |   |   |   |    | —                      | ECC                    |           |
|            | 10-20 R 2547/Mk. 39  | <b>CABLE</b> , coded "15.G.FA-TW.A4," assembly  | 1       |   |   |   |   |   |   |   |   |    | —                      | ECC                    |           |
|            | 10-20 R 2547/Mk. 40  | <b>CABLE</b> , coded "12G.FA-TW.A1," assembly   | 1       |   |   |   |   |   |   |   |   |    | —                      | ECC                    |           |
|            | 10-20 R 2547/Mk. 41  | <b>CABLE</b> , coded "14G.FA-TW.A3," assembly   | 1       |   |   |   |   |   |   |   |   |    | —                      | ECC                    |           |
|            | 10-20 R 2547/Mk. 30  | <b>CABLE</b> , coded "9A.TW-A8.13," assembly  | 1       |   |   |   |   |   |   |   |   |    | —                      | ECC                    |           |
|            | 10-20 R 3935A/ND     | <b>CABLES</b> , Starboard, group (Mods. 898 and 181)  | 1       |   |   |   |   |   |   |   |   |    | —                      | —                      |           |
|            | 10-20 R 3924A        | <b>CABLE</b> , coded "YU-FA," assembly (Mods. 898 and 181)                                      | 1       |   |   |   |   |   |   |   |   |    | —                      | ECC                    |           |
|            | 10-20 R 2547/Mk. 42  | <b>CABLE</b> , coded "17G.FA.T-T-YU.A8," assembly   | 1       |   |   |   |   |   |   |   |   |    | —                      | ECC                    |           |
|            | 10-20 R 2547/Mk. 43  | <b>CABLE</b> , coded "18G.FA.T+T-YU.A7," assembly   | 1       |   |   |   |   |   |   |   |   |    | —                      | ECC                    |           |
|            | 10-20 R 2547/Mk. 46  | <b>CABLE</b> , coded "13G.FA-YU.A2," assembly   | 1       |   |   |   |   |   |   |   |   |    | —                      | ECC                    |           |
|            | 10-20 R 2547/Mk. 47  | <b>CABLE</b> , coded "15G.FA-YU.A4," assembly   | 1       |   |   |   |   |   |   |   |   |    | —                      | ECC                    |           |

**RADIO AND RADAR INSTALLATIONS**  
**INSTALLATION OF U.H.F. RADIO AND EXTERNAL INTERCOM.**  
**(A.R.I.18124/1)**

| Ref. No.    | Part No.             | Description  | No. off | Material Specification | Class of Store or L.M. | Place No. |   |   |   |
|-------------|----------------------|--|---------|------------------------|------------------------|-----------|---|---|---|
|             |                      |  |         |                        |                        |           | 1 | 2 | 3 |
|             | 10-20 R 2547/Mk. 48  | <b>CABLE</b> , coded "11G.FA-YU.A1," assembly ...  | 1       | —                      | ECC                    |           |   |   |   |
|             | 10-20 R 2547/Mk. 49  | <b>CABLE</b> , coded "14G.FA-YU.A3," assembly ...  | 1       | —                      | ECC                    |           |   |   |   |
|             | 10-20 R 2547/Mk. 29  | <b>CABLE</b> , coded "9A.YU-A8.12," assembly ...   | 1       | —                      | ECC                    |           |   |   |   |
|             | —                    | <b>CIRCUIT-BREAKER</b> , coded "BA" on Starboard wing deck panel coded "FB" (See sub-section EBZ)  | —       | —                      | —                      |           |   |   |   |
| 28E/14200   | AS.3181/6C           | <b>CLIP</b> , "P," securing aerial cables (Pre Mod. 181) ...   | 4       | —                      | C                      |           |   |   |   |
|             | DHS.86/12            | <b>CLIP</b> , securing aerial cables, 22 SWG (Mod. 181) ...  | 5       | L.38                   | LM                     |           |   |   |   |
|             | 10-20 R 3347         | <b>CLIP</b> , "P," special, securing aerial cable, at clamp block rib No. 2, 22 SWG (Pre Mod. 181)   | 1       | L.72                   | LM                     |           |   |   |   |
|             | <del>SP.40/E44</del> | <b>GROMMET</b> , at conduit inboard of rib No. 3, Port (cut to fit)  | 1       | —                      | C                      |           |   |   |   |
|             | 10-20 R 2949A        | <b>PANEL</b> , coded "TW," external inter-com. in wing leading edge, inboard of rib No. 4, Port, assembly (Mod. 181, Pre Mod. 827)         | 1       | —                      | —                      | NH4       |   |   |   |
|             | 10-20 R 9247         | <b>PANEL</b> , coded "TW," external inter-com. in wing leading edge, inboard of rib No. 4, Port, assembly (Mod. 827)                       | 1       | —                      | —                      | NH4       |   |   |   |
|             | 10-20 R 2950A        | <b>PANEL</b> , coded "YU," external inter-com. in wing leading edge, inboard of rib No. 4, Starboard, assembly (Mod. 181)<br>Spares for :— | 1       | —                      | —                      | NH4       |   |   |   |
|             | —                    | <b>BLOCK</b> , terminal, coded "A," group ...  | 1       | —                      | —                      |           |   |   |   |
|             | DHS.456/10           | <b>BLOCK</b> , terminal, 10-way, assembly (For breakdown see DHS data sheet)   | 1       | —                      | —                      |           |   |   |   |
| 5X/1004082  | —                    | <b>LINK</b> , terminal connecting, 2 way (Fit between terminals Nos. 8 and 9)  | 1       | —                      | C                      |           |   |   |   |
| 28M/10327   | AGS.2002/B/1         | <b>NUT</b> , 4 BA (Fit at Starboard and Pre Mod. 827, Port)  | 2       | —                      | C                      |           |   |   |   |
| 5X/9450403  | PLESSEY Z.28426      | <b>PILLAR</b> , fixing ...   | 2       | —                      | C                      |           |   |   |   |
| 28W/9419401 | SP.10/B              | <b>WASHER</b> ...  | 2       | —                      | C                      |           |   |   |   |
|             | —                    | <b>BLOCK</b> , terminal, 5 way, coded "E" ... (See sub-section NK)   | 1       | —                      | —                      |           |   |   |   |
|             | 10-20 R 8081A        | <b>BRACKET</b> , mounting, terminal block and cable connector, Port, assembly (Mod. 827)   | 1       | —                      | —                      | NH4       |   |   |   |
|             | 10-20 R 8097ND       | <b>BRACKET</b> , bare, 18 SWG ...  | 1       | L.72                   | LM                     | NH4       |   |   |   |
| 28M/13307   | AGS.2018/B/1         | <b>NUT</b> , anchor, 4 BA ...  | 4       | —                      | C                      |           |   |   |   |
|             | —                    | <b>CONNECTOR</b> , cable adaptor, coded "F" ... (See sub-section NK)   | —       | —                      | —                      |           |   |   |   |

**RADIO AND RADAR INSTALLATIONS**  
**INSTALLATION OF U.H.F. RADIO AND EXTERNAL INTERCOM.**  
**(A.R.I.18124/1)**

| Ref. No.    | Part No.         | Description   |   |   |   |   |   |   |   |   |    | No. off | Material Specification | Class of Store or L.M. | Plate No. |
|-------------|------------------|---|---|---|---|---|---|---|---|---|----|---------|------------------------|------------------------|-----------|
|             |                  | 1   | 2 | 3 | 4 | 5 | 6 | 7 | 8 | 9 | 10 |         |                        |                        |           |
|             | 10-20 R 3591A/ND | <b>PANEL</b> , bare, Port, assembly ... ..            |   |   |   |   |   |   |   |   |    | 1       | —                      | —                      | NH4       |
|             | 10-20 R 3592A/ND | <b>PANEL</b> , bare, Starboard, assembly ... ..       |   |   |   |   |   |   |   |   |    | 1       | —                      | —                      | NH4       |
|             | 10-20 R 2951A    | <b>BRACKET</b> , wing inter-com., Port, assembly ...  |   |   |   |   |   |   |   |   |    | 1       | —                      | —                      | NH4       |
|             | 10-20 R 2952A    | <b>BRACKET</b> , wing inter-com., Starboard, assembly |   |   |   |   |   |   |   |   |    | 1       | —                      | —                      | NH4       |
|             | 10-20 R 2953ND   | <b>BRACKET</b> , pressing, Port, 16 SWG... ..         |   |   |   |   |   |   |   |   |    | 1       | L.72                   | LM                     | NH4       |
|             | 10-20 R 2954ND   | <b>BRACKET</b> , pressing, Starboard, 16 SWG ...      |   |   |   |   |   |   |   |   |    | 1       | L.72                   | LM                     | NH4       |
| 28M/10226   | AGS.2009/C/3     | <b>NUT</b> , 2 BA, anchor ... ..                      |   |   |   |   |   |   |   |   |    | 2       | —                      | C                      |           |
| 28M/9435106 | AGS.2009/E/3     | <b>NUT</b> , 1" BSF, anchor ... ..                    |   |   |   |   |   |   |   |   |    | 1       | —                      | C                      |           |
|             | 10-20 R 2955ND   | <b>STRIP</b> , throat, 9 SWG ... ..                   |   |   |   |   |   |   |   |   |    | 1       | L.72                   | LM                     | NH4       |
|             | 10-20 R 2957ND   | <b>STRIP</b> , throat, Port, 9 SWG ... ..             |   |   |   |   |   |   |   |   |    | 1       | L.72                   | LM                     | NH4       |
|             | 10-20 R 2958ND   | <b>STRIP</b> , throat, Starboard, 9 SWG ... ..        |   |   |   |   |   |   |   |   |    | 1       | L.72                   | LM                     | NH4       |
|             | 10-20 R 2993     | <b>BRACKET</b> , mounting, Port, 16 SWG ... ..        |   |   |   |   |   |   |   |   |    | 1       | L.72                   | LM                     | NH4       |
|             | 10-20 R 2994     | <b>BRACKET</b> , mounting, Starboard, 16 SWG ...      |   |   |   |   |   |   |   |   |    | 1       | L.72                   | LM                     | NH4       |
|             | 10-20 R 2973A/ND | <b>DOOR</b> , Port, assembly (For spares use          |   |   |   |   |   |   |   |   |    | 1       | —                      | —                      | NH4       |
|             |                  | 10-20 R 3769A/ND)                                     |   |   |   |   |   |   |   |   |    |         |                        |                        |           |
| 15324       | 10-20 R 3769A/ND | <b>DOOR</b> , Port, assembly (Spares condition) ...   |   |   |   |   |   |   |   |   |    | 1       | —                      | P                      |           |
|             | 10-20 R 2974A/ND | <b>DOOR</b> , Starboard, assembly (For spares use     |   |   |   |   |   |   |   |   |    | 1       | —                      | —                      | NH4       |
|             |                  | 10-20 R 3770A/ND)                                     |   |   |   |   |   |   |   |   |    |         |                        |                        |           |
| 15325       | 10-20 R 3770A/ND | <b>DOOR</b> , Starboard, assembly (Spares condition)  |   |   |   |   |   |   |   |   |    | 1       | —                      | P                      |           |
|             |                  | Spares for:—  |   |   |   |   |   |   |   |   |    |         |                        |                        |           |
|             | 10-20 R 2971A/ND | <b>HINGE</b> , assembly ... ..                        |   |   |   |   |   |   |   |   |    | 1       | —                      | —                      | NH4       |
|             | 10-20 R 2975ND   | <b>HINGE</b> , half (Make from Ref. No. 28N/16453)    |   |   |   |   |   |   |   |   |    | 1       | L.72                   | LM                     | NH4       |
|             |                  | 18 SWG  |   |   |   |   |   |   |   |   |    |         |                        |                        |           |
|             | 10-20 R 2977ND   | <b>HINGE</b> , half (Make from Ref. No. 28N/16453)    |   |   |   |   |   |   |   |   |    | 1       | L.72                   | LM                     | NH4       |
|             |                  | 18 SWG  |   |   |   |   |   |   |   |   |    |         |                        |                        |           |
|             | 10-20 R 2981ND   | <b>PIN</b> , hinge (Make from standard section X592)  |   |   |   |   |   |   |   |   |    | 1       | —                      | LM                     | NH4       |
|             |                  | 14 SWG  |   |   |   |   |   |   |   |   |    |         |                        |                        |           |
| 13436       | 10-20 R 2967     | <b>SPRING</b> , ... ..                                |   |   |   |   |   |   |   |   |    | 1       | —                      | C                      | NH4       |
|             | 10-20 R 3667ND   | <b>PLATE</b> , striker, 20 SWG ... ..                 |   |   |   |   |   |   |   |   |    | 1       | L.72                   | LM                     | NH4       |
|             | 10-20 R 2963ND   | <b>SEAL</b> , door, 1/2" chick (Attach with Bostik C) |   |   |   |   |   |   |   |   |    | 1       | Neoprene               | LM                     | NH4       |
|             | 10-20 R 2979     | <b>MOUNTING</b> , angle, micro-switch, Port, 18       |   |   |   |   |   |   |   |   |    | 1       | L.72                   | LM                     | NH4       |
|             |                  | SWG   |   |   |   |   |   |   |   |   |    |         |                        |                        |           |
|             | 10-20 R 2980     | <b>MOUNTING</b> , angle, micro-switch, Starboard,     |   |   |   |   |   |   |   |   |    | 1       | L.72                   | LM                     | NH4       |
|             |                  | 18 SWG  |   |   |   |   |   |   |   |   |    |         |                        |                        |           |
|             | 10-20 R 2959     | <b>PLATFORM</b> , mounting, inter-com. plugs, Port,   |   |   |   |   |   |   |   |   |    | 1       | L.72                   | LM                     | NH4       |
|             |                  | 16 SWG  |   |   |   |   |   |   |   |   |    |         |                        |                        |           |
|             | 10-20 R 2960     | <b>PLATFORM</b> , mounting, inter-com. plugs, Star-   |   |   |   |   |   |   |   |   |    | 1       | L.72                   | LM                     | NH4       |
|             |                  | board, 16 SWG   |   |   |   |   |   |   |   |   |    |         |                        |                        |           |
| 5CW/9438275 | BURGESS          | <b>SWITCH</b> , micro, Type 1A coded "D" ...          |   |   |   |   |   |   |   |   |    | 1       | —                      | P                      |           |
|             |                  | Attachments for Ref. No. 5CW/9438275, Switch:—        |   |   |   |   |   |   |   |   |    |         |                        |                        |           |
| 28D/1010142 | A25/9B           | <b>Bojt.</b> 4 BA ... ..                              |   |   |   |   |   |   |   |   |    | 2       | —                      | C                      |           |
| 28M/10287   | AGS.2001/B/1     | <b>Nut.</b> 4 BA ... ..                               |   |   |   |   |   |   |   |   |    | 2       | —                      | C                      |           |
| 13433       | DHS.781/65/16    | <b>Washer</b> ... ..                                  |   |   |   |   |   |   |   |   |    | 2       | S.510                  | C                      |           |

**RADIO AND RADAR INSTALLATIONS**  
**INSTALLATION OF U.H.F. RADIO AND EXTERNAL INTERCOM.**  
(A.R.I.18124/1)

| Ref. No.         | Part No.             | Description  | No. off | Material Specification | Class of Store or L.M. | Place No. |   |   |   |
|------------------|----------------------|--|---------|------------------------|------------------------|-----------|---|---|---|
|                  |                      |  |         |                        |                        |           | 1 | 2 | 3 |
|                  | 10-20 R 3077A        | <b>CABLE</b> , external, inter-com. mic/tel., Port, coded "C.TW." assembly                                       | 1       | —                      | ECC                    |           |   |   |   |
|                  | 10-20 R 3078A        | <b>CABLE</b> , external, inter-com. mic/tel., Starboard, coded "C.YU." assembly                                  | 1       | —                      | ECC                    |           |   |   |   |
|                  | 10-20 R 2949A/CABLES | <b>CABLES</b> , link, Port (Pre Mod. 827) ...  | QR      | —                      | ECC                    |           |   |   |   |
|                  | 10-20 R 9247/CABLES  | <b>CABLES</b> , link, Port (Mod. 827) ...  | QR      | —                      | ECC                    |           |   |   |   |
|                  | 10-20 R 2950A/CABLES | <b>CABLES</b> , link, Starboard ...  | QR      | —                      | ECC                    |           |   |   |   |
| 18240            | 10-20 R 4015         | <b>RING</b> , retaining, on mounting platform for cable socket   | 1       | —                      | C                      | NH4       |   |   |   |
|                  | DOWTY                |  |         |                        |                        |           |   |   |   |
| 5CW/5056         | C.5162Y Mk. 2        | <b>SWITCH</b> , push button, Type A, coded "B" ...<br>Attachments for Ref. No. 5CW/5056, Switch:—                | 1       | —                      | C                      |           |   |   |   |
| 28M/9403517      | A47/Z                | Nut, 8 BA  | 2       | —                      | C                      |           |   |   |   |
| 28S/1213423      | A32/Z14              | Screw, 8 BA  | 2       | —                      | C                      |           |   |   |   |
| 20414            | 10-20 R 3783         | Spacer, 1"26 x 0"89 x 0"2 thick  | 1       | —                      | C                      |           |   |   |   |
| 28W/16096        | AGS.2035/AA          | Washer, shakeproof   | 2       | —                      | C                      |           |   |   |   |
|                  |                      | Attachments for 10-20 R 2949A, 10-20 R 9247 or 10-20 R 2950A, Panel:—  |         |                        |                        |           |   |   |   |
| 1660             | DHS.358/4C           | Bolt, 1 BA   | 2       | —                      | C                      |           |   |   |   |
| 2348             | DHS.358/4E           | Bolt, 1" BSF   | 1       | —                      | C                      |           |   |   |   |
|                  | —                    | <b>INSTALLATION IN PORT BOOM</b> (Drg. No. 10-20 R 3555 (Mod. 181))  | 1       | —                      | —                      |           |   |   |   |
|                  | 10-20 R 3441A        | <b>CABLE</b> , co-axial, coded "UPPER.AE-Q37," assembly  | 1       | —                      | ECC                    |           |   |   |   |
|                  | —                    | <b>INSTALLATION OF UPPER U.H.F. AERIAL</b> (Drg. No. 10-20 R 3331)   | 1       | —                      | —                      |           |   |   |   |
| 5985-99-932-6362 | DERVEAUX             | <b>AERIAL</b> , Type 248   | 1       | —                      | P                      |           |   |   |   |
| OR               | OR                   |  |         |                        |                        |           |   |   |   |
| 5985-99-911-8266 | McMICHAEL            | <b>AERIAL</b>  | 1       | —                      | P                      |           |   |   |   |
|                  |                      | Attachments for 5985-99-932-6362 or 5985-99-911-8266, Aerial:—   |         |                        |                        |           |   |   |   |
| 28D/9709461      | AS.1242/3C           | Bolt, 1 BA   | 8       | —                      | C                      |           |   |   |   |
| 28M/10288        | AGS.2001/C/1         | Nut, 2 BA  | 8       | —                      | C                      |           |   |   |   |
| 28W/9419402      | SP.13/C              | Washer   | 8       | —                      | C                      |           |   |   |   |
| 5K/3415          | AS.3360/B8C          | <b>LEAD</b> , bonding, flexible at panel coded "AF" ...<br>Attachments for AS.3360/B5C or AS.3360/B8C, Lead:—    | 2       | —                      | C                      |           |   |   |   |
| 28M/10287        | AGS.2001/B/1         | Nut, 4 BA  | 1       | —                      | C                      |           |   |   |   |
| 28S/9992522      | A32/B16              | Screw, 4 BA  | 1       | —                      | C                      |           |   |   |   |
| 28W/9419465      | SP.13/B              | Washer   | 1       | —                      | C                      |           |   |   |   |
| 5F/9434858       | HELLERMANN HV.3254   | <b>STRAP</b> , cable fastening, 1/8" wide  | QR      | P.V.C.                 | C                      |           |   |   |   |
| 5F/9434857       | HELLERMANN HV.3341   | <b>STRAP</b> , cable fastening, 1/8" wide  | QR      | P.V.C.                 | C                      |           |   |   |   |
| 5F/9138823       | HELLERMANN NY.3255   | <b>STUD</b> , for 1/8" cable strap   | QR      | Nylon                  | C                      |           |   |   |   |
| 5F/2302          | HELLERMANN NY.3342   | <b>STUD</b> , for 1/8" cable strap   | QR      | Nylon                  | C                      |           |   |   |   |
| 32B/—            | —                    | <b>TAPE</b> , identification, numbers and letters, use from Ref. No. 32B/1087 to 32B/1120 inclusive, as required | QR      | —                      | C                      |           |   |   |   |

**RADIO AND RADAR INSTALLATIONS**  
**INSTALLATION OF U.H.F. RADIO AND EXTERNAL INTERCOM.**  
**(A.R.I.18124/1)**

| Ref. No. | Part No. | Description |   |   |   |   |   |   |   |   |    | No. off | Material Specification | Class of Store or L.M. | Plate No. |  |
|----------|----------|-------------|---|---|---|---|---|---|---|---|----|---------|------------------------|------------------------|-----------|--|
|          |          | 1           | 2 | 3 | 4 | 5 | 6 | 7 | 8 | 9 | 10 |         |                        |                        |           |  |
|          |          |             |   |   |   |   |   |   |   |   |    |         |                        |                        |           |  |

NH.1

# RADIO AND RADAR U.H.F. RADIO & EXTERNAL INTERCOMM. A.R.I.18124/1

RESTRICTED

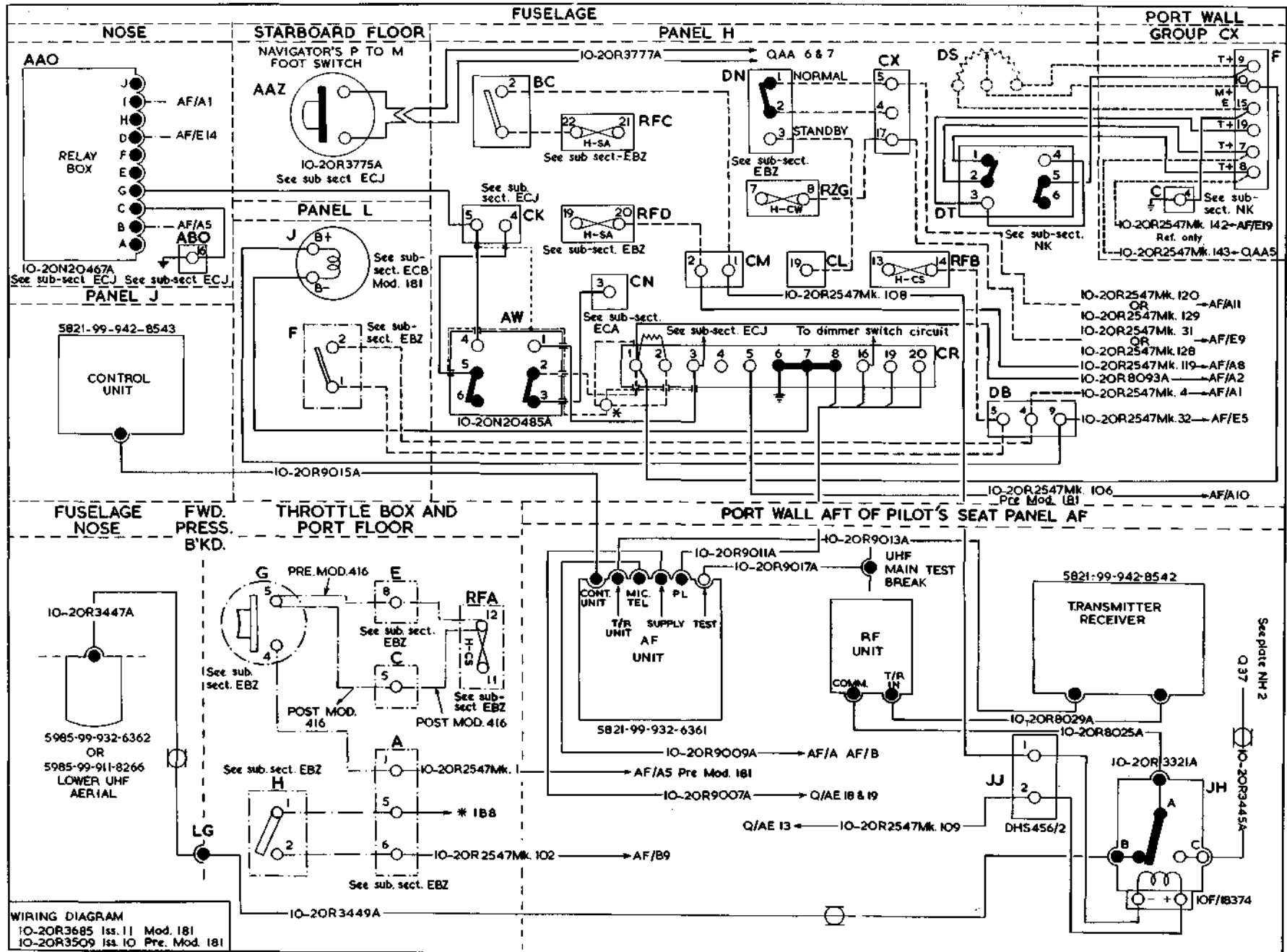

See Vixen Mk. 1

RESTRICTED

Plate NH1

NH.1  
AL 45



NH.3

**RADIO AND RADAR**  
U.H.F. RADIO & EXTERNAL INTERCOMM.  
A.R.I.18124/1

NH.3  
AL 60

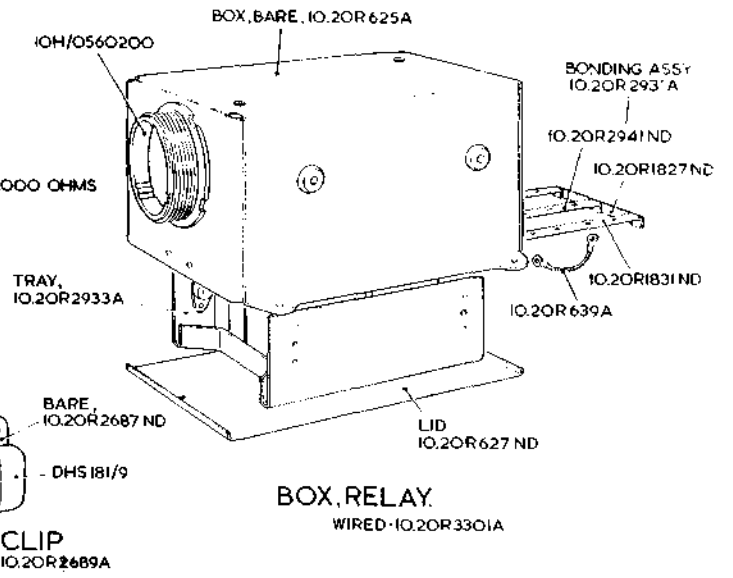
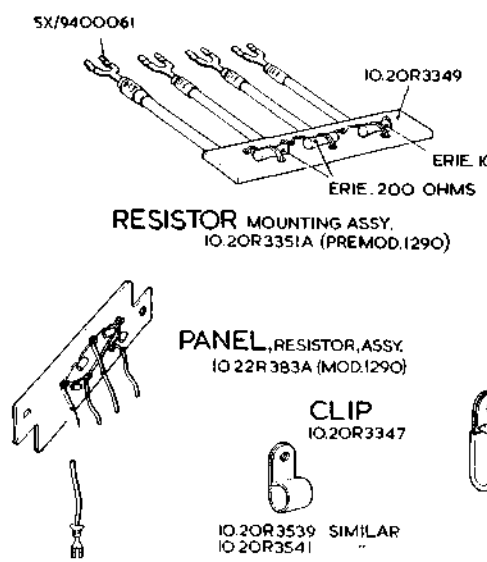
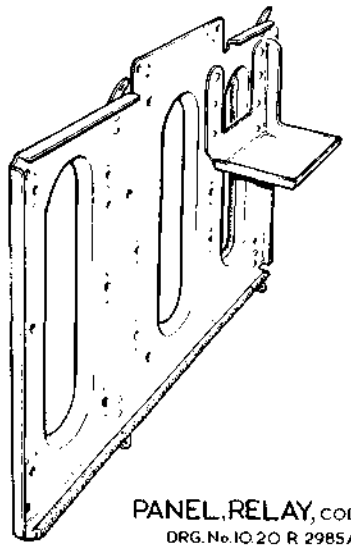
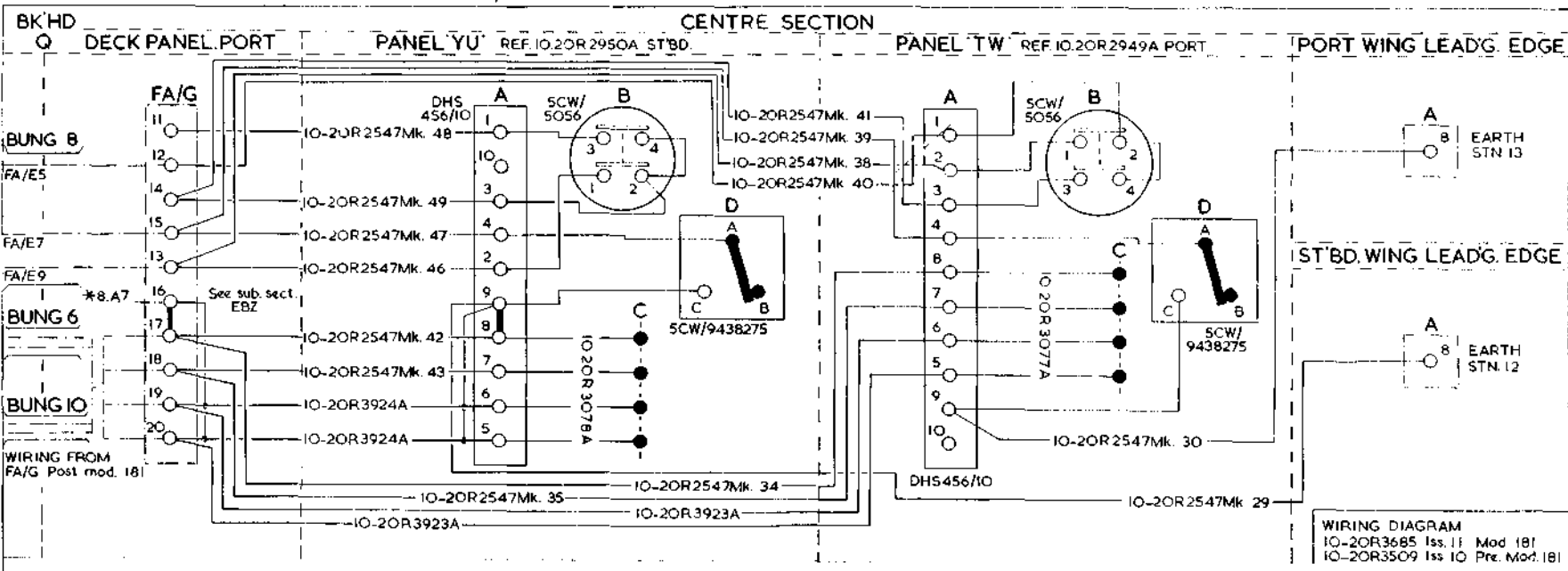

See Vixen Mk. 1

RESTRICTED

Plate NH.3

SEE TEXT FOR SPARES CONDITION OF ITEMS MARKED THUS: \*

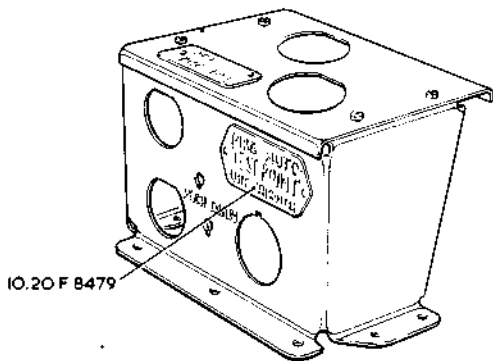

IO.20 F 8479

BRACKET, UHF RADIO, & MRG TEST POINT IO.20 F 8427A (MOD.1006)

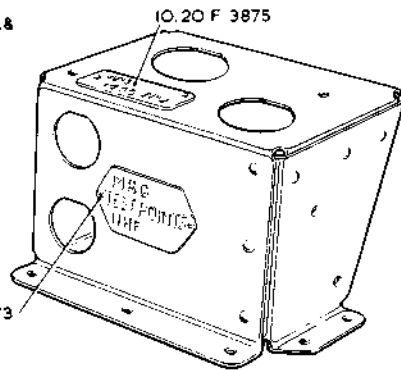

IO.20 F 3873

BRACKET, UHF RADIO, MRG. & AUTO-THROTTLE TEST POINT ASSY. IO.20 F 8541A (MOD.1428) IO.20 F 8479

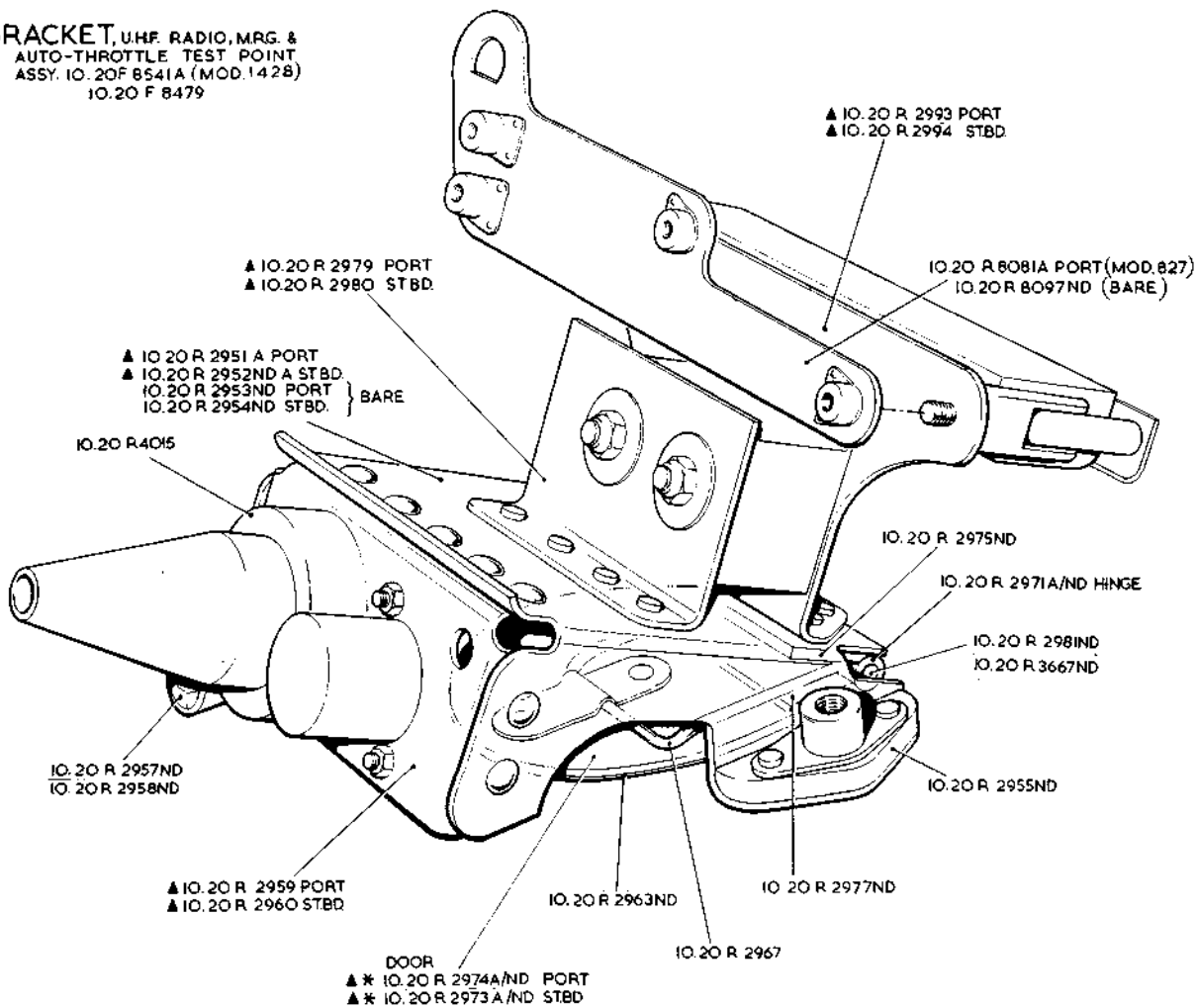

▲ IO.20 R 2979 PORT  
▲ IO.20 R 2980 STBD.

▲ IO.20 R 2951 A PORT  
▲ IO.20 R 2952ND A STBD.  
IO.20 R 2953ND PORT  
IO.20 R 2954ND STBD. } BARE

IO.20 R4015

IO.20 R 2957ND  
IO.20 R 2958ND

▲ IO.20 R 2959 PORT  
▲ IO.20 R 2960 STBD.

DOOR  
▲ \* IO.20 R 2974A/ND PORT  
▲ \* IO.20 R 2973 A/ND STBD

▲ IO.20 R 2993 PORT  
▲ IO.20 R 2994 STBD.

IO.20 R 8081A PORT (MOD.827)  
IO.20 R 8097ND (BARE)

IO.20 R 2975ND

IO.20 R 2971A/ND HINGE

IO.20 R 2981ND  
IO.20 R 3667ND

IO.20 R 2955ND

IO.20 R 2963ND

IO.20 R 2977ND

IO.20 R 2967

IO.20 R 3591 A/ND PANEL, BARE PORT } COMPRISING ITEMS  
IO.20 R 3592 A/ND PANEL, BARE STBD } MARKED ▲

PANEL, 'TW', EXTERNAL INTER-COM, PORT (PRE-MOD. 1101)  
PANEL, 'YU', EXTERNAL INTER-COM, STARBOARD  
(DRG. NOS. IO.20 R 2949A PRE-MOD 1101,  
IO.20 R 9247 MOD. 1101) PORT AND IO.20 R 2950A STBD.)

This file was downloaded  
from the RTFM Library.

Link: [www.scottbouch.com/rtfm](http://www.scottbouch.com/rtfm)

Please see site for usage terms,  
and more aircraft documents.

