

RAM AIR TURBINE

			No.	Material Specification	Class of Drawing or Code	Plate No.
		INSTALLATION OF RAM AIR TURBINE ...	1	—	—	QC1
		(Drg. No. 10-20 WC 28039) (Mod. 216)				
16052	10-20 WC 28069	ANCHORAGE , damper, ram air turbine, on side beam	1	—	C	QC1
		Attachments for 10-20 WC 28069, Anchorage :—				
28D/1008151	A25/4E	Bolt, 1/2" BSF	4	—	C	
28D/1011240	A25/5E	Bolt, 1/2" BSF	4	—	C	
28D/1010031	A25/8E	Bolt, 1/2" BSF	2	—	C	
28M/1007403	A27/ET	Nut, 1/2" BSF	10	—	C	
16054	10-20 WC 28075	Shim, 1/16" thick	2	—	C	QC1
16056	10-20 WC 28077	Shim, 1/16" thick	2	—	C	QC1
28W/9419405	SP.15/E	Washer	10	—	C	
		10-20 WC 30689A				
		ARM , swinging, ram air turbine, assembly (Mod. 830)	1	—	—	QC1
		Spares for :—				
16080	10-20 WC 28043A	ARM , swinging, assembly	1	—	P	QC1
		Spares for :—				
16081	10-20 WC 28149	BUSH , bearing, for flanged ends	2	—	C	QC1
16070	10-20 WC 28021	BALL , end fitting door operating rod	2	—	C	QC1
16074	10-20 WC 30339	BAR , locking, ram air turbine (Mod. 830)	1	—	C	QC1
		Attachments for 10-20 WC 30339, Bar :—				
28M/7002430	AGS.2002/E/1	Nut, 1/2" BSF	2	—	C	
	AS.2806/5/095	Tube, distance, 5/16" o/d x 22 SWG x 0"-95 long	2	T.35	LM	
	AS.2806/6/090	Tube, distance, 3/8" o/d x 22 SWG x 0"-90 long	2	T.35	LM	
16071	10-20 WC 28493	BEARING , housing, for ball end fitting	2	—	C	QC1
		Attachments for 10-20 WC 28493, Bearing :—				
28D.9140645	A25/10C	Bolt, 2 BA	2	—	C	
28M.9403520	A27/CP	Nut, 2 BA	2	—	C	
16067	10-20 WC 30109ND	Washer, rubber, 1/16" o/d x 1/16" i/d x 0"-07 thick	2	—	C	QC1
16072	10-20 WC 28495	BEARING , cup, for ball-end fitting	2	—	C	QC1
16066	10-20 WC 30691	BEARING , flanged, end, at hinge point, L.H. (Mod. 830)	1	—	C	QC1
16068	10-20 WC 30692	BEARING , flanged, end, at hinge point, R.H. (Mod. 830)	1	—	C	QC1
28N/9143884	AGS.596/C	CAP , protective, at pipe connections	2	—	C	
28E/9488798	AS.3181/6B	CLIP , "P" securing pipes in swing arm	2	—	C	
		Attachments for AS.3181/6B, Clip :—				
28D/1008149	A25/2B	Bolt, 4 BA	1	—	C	
28M/10287	AGS.2001/B/1	Nut, 4 BA	1	—	C	
28W/9419474	SP.15/B	Washer	1	—	C	
28Q/70144	DOWTY 12118.Y801	COUPLING , swivel, assembly (For spares see AP.4515B, Vol. 3, Pt. 1, Sect. 2, Chap. 22)	1	—	P	QC1
27Q	10-20 WC 28511	FORK , torque, at swivel coupling, 14 SWG	2	L.72	LM	QC1
		Attachments for 10-20 WC 28511, Fork :—				
28D/9133011	A25/2C	Bolt, 2 BA	2	—	C	
28D/1011022	A25/18C	Bolt, 2 BA	1	—	C	
28M/10288	AGS.2001/C1	Nut, 2 BA	3	—	C	
	AS.2806/4/040	Tube, distance, 1/2" o/d x 22 SWG x 0"-40 long	1	T.35	LM	
28W/9419402	SP.13/C	Washer	3	—	C	

SERVICES
RAM AIR TURBINE

Ref. No.	Part No.	Description	No. off	Material Specification	Class of Store or L.M	Plate No.
16076	10-20 S 14169A/ND	PIPE , pressure, from pump to swivel coupling, assembly	1	—	C	QC1
16077	10-20 S 14171A/ND	PIPE , suction, from pump to swivel coupling, assembly	1	—	C	QC1
5486	10-20 S 9193	PLATE , locking	1	—	C	QC1
5487	10-20 S 9195	PLATE , locking	1	—	C	QC1
16078	10-20 WC 30401A	PLATE , lock, winching, L.H. (Mod. 830) assembly	1	—	C	QC1
16079	10-20 WC 30402A	PLATE , lock, winching, R.H. (Mod. 830) assembly	1	—	C	QC1
	10-20 WC 30407ND	Spares for :— PAD , rubber, 1"25 × 0"40 × 0"125, shore hardness 40°	1	DHA.34	LM	QC1
		Attachments for 10-20 WC 30401A or 10-20 WC 30402A, Plate :—				
28D/9133012	A25.3C	Bolt, 2 BA	2	—	C	
28M/10328	AGS.2002/C/1 AS.2806/4/010	Nut, 2 BA Tube, distance, 1/4" o/d × 22 SWG × 0"10 long	2 2	— T.35	C LM	
37J/12001	PLESSEY CK.18920	PUMP , ram air turbine (For spares see AP.4515L Vol. 3)	1	—	P	QC1
		Attachments for CK.18920, Pump :—				
18291	A.102/5E/DHS.514/D	Bolt, 1/2" UNF	6	—	C	QC1
28W/9419405	SP.15/E	Washer	6	—	C	
27QA/489	DOWTY SP.915A/2	RING , sealing, at pipe connections	2	—	C	QC1
16075	10-20 WC 28079	SPRING , retaining, winching plate	2	—	C	QC1
		Attachments for 10-20 WC 28079, Spring :—				
28D/7002428	A25.6C	Bolt, 2 BA	1	—	C	
28D/13712	A25.41E	Bolt, 1/2" BSF	1	—	C	
28M/10288	AGS.2001/C/1	Nut, 2 BA	1	—	C	
28M/10290	AGS.2001/E/1	Nut, 1/2" BSF	1	—	C	
26FC/8577	DHS.180.Mk. 4/X	Tag	1	—	C	
	AS.2806/4/018	Tube, distance, 1/4" o/d × 22 SWG × 0"18 long	1	T.35	LM	
	AS.2806/5/390	Tube, distance, 1/8" o/d × 22 SWG × 3"9 long	1	T.35	LM	
28W/9418921	SP.13/E	Washer	1	—	C	
28W/9418920	SP.10/E	Washer	1	—	C	
16073	10-20 WC 28497	SPRING , retaining, cup bearing	2	—	C	QC1
16069	10-20 WC 28515	TUBE , distance, at swivel coupling	2	—	C	QC1
		Attachments for 10-20 WC 30689A, Arm :—				
28D/1011238	A25.3E	Bolt, 1/2" BSF	4	—	C	
28D/10.1240	A25.5E	Bolt, 1/2" BSF	2	—	C	
28D/9798	AS.1248/3E	Bolt, 1/2" BSF	4	—	C	
28M/10290	AGS.2001/E/1	Nut, 1/2" BSF	10	—	C	
16053	10-20 WC 28073	Shim	2	—	C	QC1
28W/9419405	SP.15/E	Washer	6	—	C	
28W/9419487	SP.16/E	Washer	4	—	C	

SERVICES

RAM AIR TURBINE

Ref. No.	Part No.	Description	No. off	Material Specification	Class of Store or L.M.	Place No.
27M/819	LOCKHEED AIR.44208	DAMPER , ram air turbine (For spares see AP.4515.F, Vol. 3, Sect. 2, Chap. 23) Attachments for AIR.44208, Damper :—	1	—	P	QC1
17345	10-20 WC 40811A	Bolt, special, shear, assembly (upper fitting) (Mod. 1186)	1	—	C	QC1
16055	10-20 WC 28153	Bolt, special, shear (lower fitting)	1	—	C	QC1
28M/14555	A58/NS	Nut, 1/2" BSF	2	—	C	
28P/9429652	SP.9/E10	Pin, split	2	—	C	
16057	10-20 WC 28157	Tube, distance (lower fitting)	2	—	C	QC1
16058	10-20 WC 28159	Tube, distance (upper fitting)	2	—	C	QC1
28W/9419458	SP.10/N	Washer	2	—	C	
16774	10-20 WC 28621A	HOOK , down, ram air turbine, assembly Spares for :—	1	—	P	QC1
28D/9434862	A61/6C	BOLT , stop, damper catch Attachments for A61/6C, Bolt :—	2	—	C	
28M/10288	AGS.2001/C/1	Nut, 2 BA	1	—	C	
	10-20 WC 28053ND	Tube, distance, 5/16" o/d x 0"-50, long (upper bolt)	1	L.64	LM	QC1
	AS.2806/4/050	Tube, distance, 1/4" o/d x 22 SWG x 0"-50 long (lower bolt)	1	T.35	LM	
16065	10-20 WC 28627A	CATCH , assembly Spares for :—	1	—	C	QC1
2A.9501380	—	BEARING , ball	1	—	C	QC1
		Attachments for 10-20 WC 28627A, Catch :—				
16062	10-20 WC 28615	Bolt, 3/8" BSF	1	—	C	QC1
28M/13451	A29/JS	Nut, 3/8" BSF	1	—	C	
28P/1007741	SP.9/C8	Pin, split	1	—	C	
16061	10-20 WC 28611	FITTING , end, catch retaining, group FITTING , end	1 1	— —	— C	QC1
		Attachments for 10-20 WC 28611, Fitting :—				
28P/815	SP.4Y/A5	Pin, shackle, 5/16" dia.	1	—	C	
28P/1007741	SP.9/C8	Pin, split	1	—	C	
16064	10-20 WC 28619	SPRING	1	—	C	QC1
16063	10-20 WC 28617	SUPPORT , spring Attachments for 10-20 WC 28617, Support :—	1	—	C	QC1
28D/9434862	A61/6C	Bolt, 2 BA	1	—	C	
28M/10288	AGS.2001/C/1	Nut, 2 BA	1	—	C	
	AS.2806/4/050	Tube, distance, 1/4" o/d x 22 SWG x 0"-50 long	1	T.35	LM	
		Attachments for 10-20 WC 28621A, Hook :—				
28D/1011245	A25/10E	Bolt, 1/4" BSF	2	—	C	
28M/10290	AGS.2001/E/1	Nut, 1/4" BSF	2	—	C	
26FN/3275	DHS.69/DD	Shim	4	—	C	
	AS.2806/5/060	Tube, distance, 5/16" o/d x 22 SWG x 0"-60 long	2	T.35	LM	
28W/9419405	SP.15/E	Washer	2	—	C	
16059	10-20 WC 28065	ROD , actuating, ram air turbine door Attachments for 10-20 WC 28065, Rod :—	2	—	C	QC1
28M/1007403	A27/ET	Nut, 1/4" BSF	2	—	C	
28P/9429652	SP.9/E10	Pin, split	2	—	C	

SERVICES
RAM AIR TURBINE

Ref. No.	Part No.	Description						No. of	Material Specification	Class of Store or L.M.	Plate No.
		1	2	3	4	5	6				

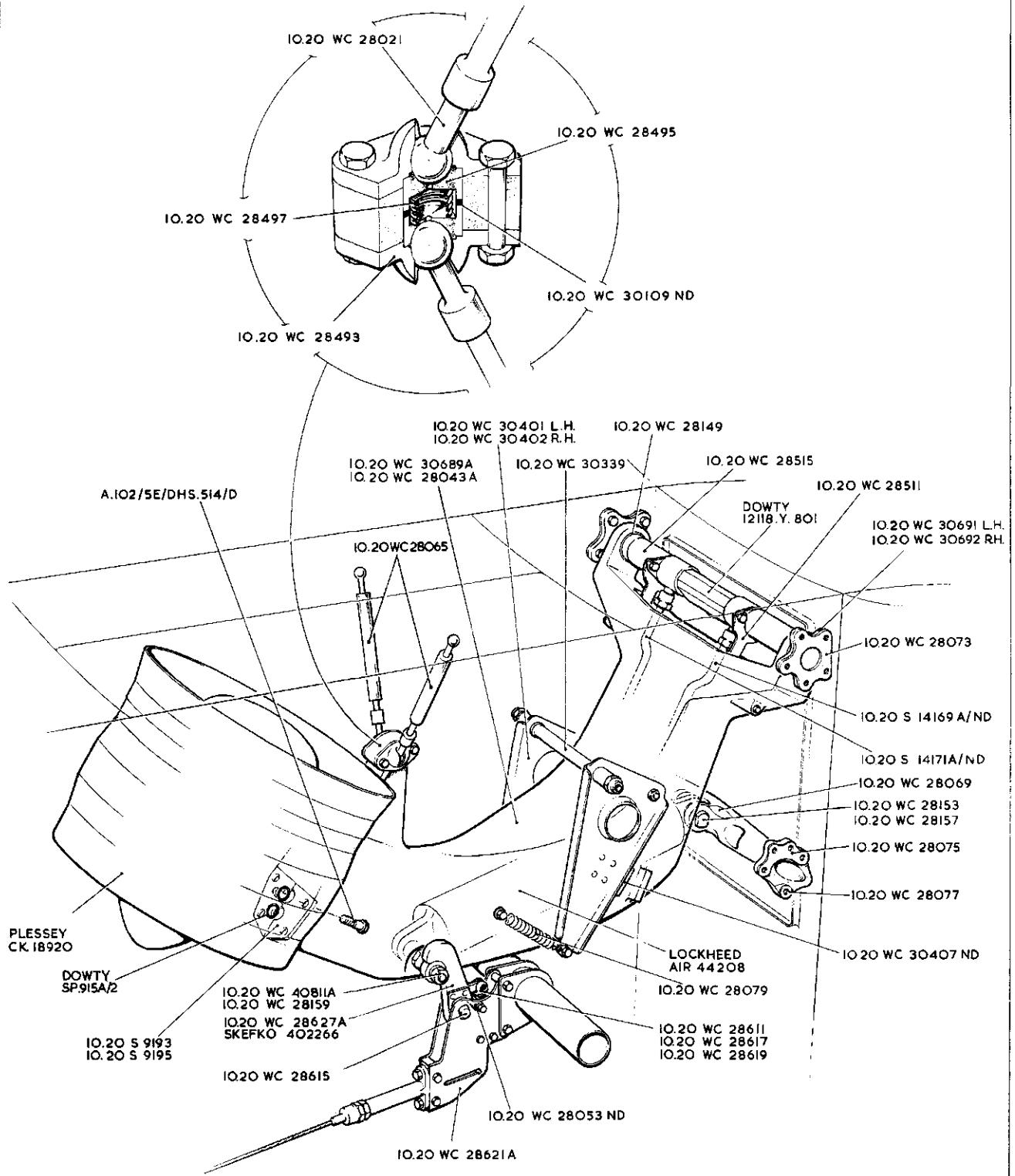

RAM AIR TURBINE.
 (DRG. No. IO.20 WC 28039)
 (MOD. 216)

QC.I

SERVICES

QC.I

RAM AIR TURBINE

[AL.4.4]



This file was downloaded from the RTFM Library.

Link: www.scottbouch.com/rtfm

Please see site for usage terms, and more aircraft documents.