

SERVICES

AIR STARTER PIPES

Ref. No.	Part No.	Description	No. off	Material Specification	Class of Score or L.M	Plate No.
	—	AIR STARTER PIPES	1	—	—	
	—	PIPES, LOW PRESSURE AIR STARTER, PORT ENGINE, group (Drg. Nos. 10-20 S 7487, 10-20 S 12143)	1	—	—	QE1
9750	10-20 S 11993A	BRACKET, mounting, air trolley plug connector, assembly	1	—	C	QE1
28E/9130219	AGS.605/4	Attachments for 10-20 S 11993A, Bracket :— Clip, hose, adjustable	2	—	C	QE1
10317	10-20 S 12031A	CAP, blanking, assembly	1	—	C	QE1
28D/1013172	AS.1242/5C	BOLT, 2 BA	3	—	C	
	10-20 S 12033	CAP	1	L.64	—	QE1
28M/9403520	A27/CP	NUT, 2 BA	3	—	C	
	10-20 S 12035	PLATE, locking	1	S.521	—	QE1
10318	10-20 S 12095	SPRING	3	—	C	QE1
26DL/7354	DHS.180 Mk. 1/X	TAG	1	—	C	QE1
	AS.2806/4/030	TUBE, distance, 1/4" o/d x 22 SWG x 3 long	3	T.35	LM	QE1
28W/9419402	SP.13/C	WASHER	3	—	C	
18910	DHS.1150/C/8/PVC	Attachments for 10-20 S 12031A, Cap :— Cable, assembly (Mod. 1261)	1	—	C	QE1
26DL/7354	DHS.180 Mk. 1/X	Tag	1	—	C	QE1
10522	10-20 S 9681A	COUPLING, air starter c/w elbow, assembly ...	1	—	C	QE1
		Spares for :—				
11728	10-20 S 12687A/ND	COUPLING (with pins), assembly	1	—	C	QE1
	—	Attachments for 10-20 S 9681A, Coupling :—				
18910	DHS.1150/C/8/PVC	Pin, "Pip" quick release, group	1	—	—	
28FP/953	AGS.2106/409	Cable, assembly (Mod. 1261)	1	—	C	QE1
26FN/3285	DHS.180 Mk. 3/X	Pin, "Pip" quick release	1	—	C	QE1
10523	10-20 S 7507	Tag	1	—	C	QE1
		Screw, stop	2	—	C	QE1
10450	10-20 S 7141	COUPLING, at engine	1	—	C	QE1
		Attachments for 10-20 S 7141, Coupling :—				
28D/1008145	A25/6E	Bolt, 1/4" BSF	3	—	C	
28M/1011475	A27/EP	Nut, 1/4" BSF	3	—	C	
26DV/12715	DHS.413/8	Ring, sealing	1	—	C	QE1
	OR					
28F/18039	AS.5403					
28W/9418921	SP.13/E	Washer	3	—	C	
28W/9416644	SP.47/E	Washer, spring	3	—	C	

SERVICES
AIR STARTER PIPES

Ref. No.	Part No.	Description	No. off	Material Specification	Class of Store or L.M	Place No.
8305	10-20 S 9671A	JOINT , flexible, assembly	1	—	P	QE1
		Spares for :—				
10453	10-20 S 7493	BEARING	2	—	C	QE1
10451	10-20 S 7511	HOUSING , bearing	1	—	C	QE1
10452	10-20 S 7513	HOUSING , bearing	1	—	C	QE1
10454	10-20 S 7561	RING , sealing	2	—	C	QE1
	10-20 S 9657	SLIDE	1	—	—	QE1
		Attachments for 10-20 S 9671A, Joint :—				
	KING AIRCRAFT					
14463	C.4205/3H	Clamp	1	—	C	QE1
5835	DHS.413/12	Ring, sealing	1	—	C	QE1
	OR					
28F/17516	AS.5406				/	
10520	10-20 S 7559	RING , sealing, sleeve and coupling joint	1	—	C	QE1
10521	10-20 S 7563	RING , sealing, sleeve and flexible joint	1	—	C	QE1
8306	10-20 S 9647	SLEEVE	1	—	C	QE1
		Attachments for 10-20 S 9647, Sleeve :—				
28D/9133012	A25/3C	Bolt, 2 BA	3	—	C	
28D/1011238	A25/3E	Bolt, 1/4" BSF	2	—	C	
28M/9403520	A27/CP	Nut, 2 BA	3	—	C	
28M/1011475	A27/EP	Nut, 1/4" BSF	2	—	C	
28W/9419402	SP.13/C	Washer	3	—	C	
28W/9418921	SP.13/E	Washer	2	—	C	

SERVICES
AIR STARTER PIPES

Ref. No.	Part No.	Description 1 2 3 4 5 6	No. off	Material Specification	Class of Store or L.M	Place No.
	—	PIPES, LOW PRESSURE, AIR STARTER, STARBOARD ENGINE, group (Drg. Nos. 10-20 S 7515, 10-20 S 12143)	1	—	—	QE2
	10-20 S 11741	BRACKET, support (For spares use 10-20 S 14405ND)	1	—	—	QE2
14687	10-20 S 14405ND	BRACKET, support (Spares condition) ...	1	—	C	
10317	10-20 S 12031A	CAP, blanking, assembly ...	1	—	C	QE2
28D/1013172	AS.1242/5C	BOLT, 2 BA ...	3	—	C	
	10-20 S 12033	CAP ...	1	L.64	—	QE2
28M/9403520	A27/CP	NUT, 2 BA ...	3	—	C	
	10-20 S 12035	PLATE, locking ...	1	S.521	—	QE2
10318	10-20 S 12095	SPRING ...	3	—	C	QE2
26DL/7354	DHS.180 Mk. 1/X	TAG ...	1	—	C	QE2
	AS.2806/4/030	TUBE, distance, 1/2" o/d x 22 SWG x 1/3 long	3	T.35	LM	QE2
28W/9419402	SP.13/C	WASHER ...	3	—	C	
		Attachments for 10-20 S 12031A, Cap :—				
18910	DHS.1150/C/8/PVC	Cable, assembly ...	1	—	C	QE2
26DL/7354	DHS.180 Mk. 1/X	Tag ...	1	—	C	QE2
	10524	CONNECTION, air starter, assembly ...	1	—	C	QE2
		Spares for :—				
28N/9156370	SP.21	NIPPLE, lubrication ...	1	—	C	QE2
10459	10-20 S 7521	NUT, barrel ...	1	—	C	QE2
10319	10-20 S 12145	PIN ...	3	—	C	QE2
8303	10-20 S 9677A/ND	PIPE, assembly ...	1	—	C	QE2
10460	10-20 S 7529	LINER ...	1	—	C	QE2
8302	10-20 S 9679	PIPE ...	1	—	C	QE2
10525	10-20 S 7567	RING, sealing ...	1	—	C	QE2
10320	10-20 S 12363	SCREW, locking ...	2	—	C	QE2
15163	10-20 S 7537	STUD, stop ...	2	—	C	QE2
		Attachments for 10-20 S 9675A, Connection :—				
28D/1010030	A25/7C	Bolt, 2 BA ...	4	—	C	
28M/9403520	A27/CP	Nut, 2 BA ...	4	—	C	
18759	10-20 S 7569	Shim ...	1	—	C	QE2
28W/9419402	SP.13/C	Washer ...	4	—	C	
	10456	COUPLING, at engine ...	1	—	C	QE2
		Attachments for 10-20 S 7143, Coupling :—				
28D/1008145	A25/6E	Bolt, 1/2" BSF ...	3	—	C	
28M/1011475	A27/EP	Nut, 1/2" BSF ...	3	—	C	
26DV/12715	DHS.413/8	Ring, sealing ...	1	—	C	QE2
	OR					
28F/18039	AS.5403	Seal ...	1	—	C	QE2
10457	10-20 S 7565	Washer ...	3	—	C	
28W/9418921	SP.13/E	Washer, spring ...	3	—	C	
28W/9416644	SP.47/E					

**SERVICES
AIR STARTER PIPES**

Ref. No.	Part No.	Description	No. off	Material Specification	Class of Score or L.M.	Plate No.
10458	10-20 S 7533	COUPLING , flange, support bracket	1	—	C	QE2
8301	10-20 S 9649	FLANGE , support bracket	1	—	C	QE2
		Attachments for 10-20 S 9649, Flange :—				
28D/1200119	A25/4C	Bolt, 2 BA	6	—	C	
28M/1006473	A27/CT	Nut, 2 BA	6	—	C	
28W/9419402	SP.13/C	Washer	6	—	C	
8304	10-20 S 9673A	JOINT , flexible, assembly	1	—	P	QE2
		Spares for :—				
10453	10-20 S 7493	BEARING	2	—	C	QE2
10451	10-20 S 7511	HOUSING , bearing	1	—	C	QE2
10452	10-20 S 7513	HOUSING , bearing	1	—	C	QE2
10454	10-20 S 7561	RING , sealing	2	—	C	QE2
	10-20 S 9663	SLIDE	1	—	—	QE2
		Attachments for 10-20 S 9673A, Joint :—				
14463	KING AIRCRAFT C.4205/3/H	Clamp	1	—	C	QE2
5835	DHS.413/12 OR	Ring, sealing	1	—	C	QE2
28F/17516	AS.5406					

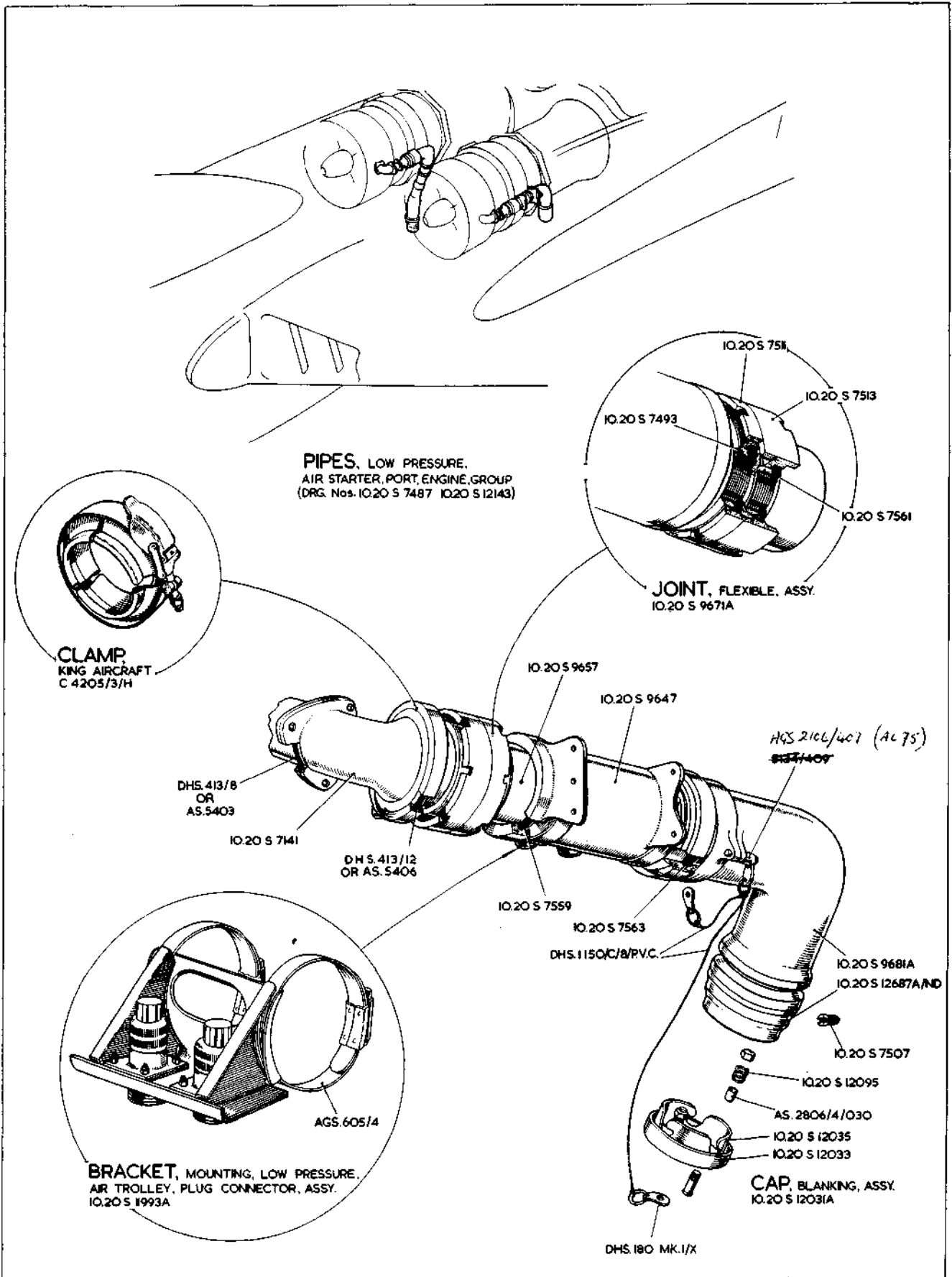

QE.1

SERVICES

QE.1
[AL.56]

AIR STARTER PIPES

SEE TEXT FOR SPARES CONDITION OF ITEMS MARKED THUS— *

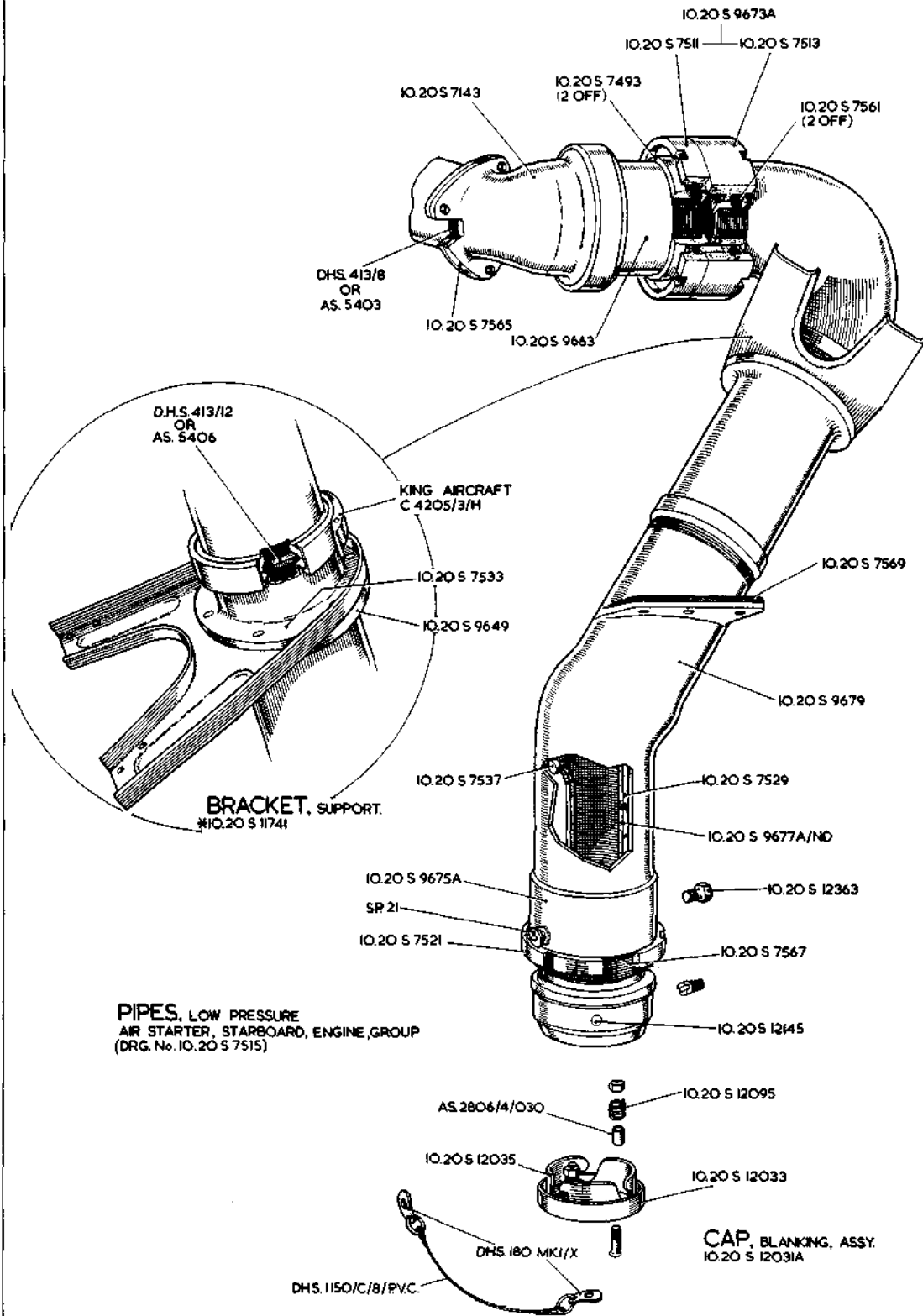

QE.2

SERVICES

QE.2
[AL56]

AIR STARTER PIPES



This file was downloaded
from the RTFM Library.

Link: www.scottbouch.com/rtfm

Please see site for usage terms,
and more aircraft documents.