

SERVICES

ANTI-"G" SYSTEM

| Ref. No. | Part No. | Description | No. off | Material Specification | Class of Store or L.M | Place No. |
|-------------|------------------------|--|---------|------------------------|-----------------------|------------|
| | | | | | | |
| | — | INSTALLATION OF ANTI-"G" SYSTEM IN FUSELAGE (For seats fitted with personal equipment connectors) (Drg. No. 10-20 S 14641) (Mod. 439) | 1 | — | — | QF1 |
| | DUNLOP DAS.412/E6 | HOSE , anti-kink, at navigator's anti-"G" valve, 6"0 long | 1 | DTD.625 | — | QF2 |
| 28E/1007984 | AGS.605/1A | Attachments for DAS.412/E6, Hose :— Clip, hose, adjustable | 2 | — | C | |
| 15295 | DUNLOP DAS.412/E15½ | HOSE , anti-kink, between anti-"G" valve and combined anti-"G" and ventilated suit connection on pilot's and navigator's seat | 2 | — | C | QF1 |
| 28E/9129090 | AGS.605/0 | Attachments for DAS.412/E15½, Hose :— Clip, hose, adjustable | 1 | — | C | |
| 5K/ | AS.3360/9C | LEAD , bonding, flexible, at navigator's anti-"G" valve | 1 | — | C | |
| 28D/9133012 | A25/2C | Attachments for AS.3360/9C, Lead :— Bolt, 2 BA | 1 | — | C | |
| 28E/18739 | AGS.2081/16 | Clip, "P" | 1 | — | — | |
| 28M/10288 | AGS.2001/C/1 | Nut, 2 BA | 1 | — | C | |
| 28W/9419402 | SP.13/C | Washer | 1 | — | C | |
| 28F/9439897 | AGS.1142/E | NIPPLE , adapter at connections of pipes code Nos. 1, 2, 3 and 4 | 9 | — | C | |
| 28F/10772 | AGS.1170/E | NIPPLE , at connections of pipes code No. 1 | 4 | — | C | |
| 15381 | 10-20 S 14695ND | PIPES , coded No. 1, missile heating pipe connection to stop valve, group PIPE , between joint aft of stn. 176" and joint at bulkhead adapter at stn. 148", assembly (Mod. 377) | 1 | — | C | QF1 QF2 |
| 28D/9137408 | AS.1246/½B | Attachments for 10-20 S 14695ND, Pipe :— Bolt, 4 BA | 3 | — | C | |
| 28E/9128270 | AGS.2080/10 | Clip, "P" | 3 | — | C | |
| 28W/9419465 | SP.13/B | Washer | 3 | — | C | |
| 10079 | 10-20 S 9741ND | PIPE , between second joint at bulkhead adapter at stn. 148" and third joint at port side fuselage, assembly | 1 | — | C | QF1 QF2 |
| 28D/9137408 | AS.1246/½B | Attachments for 10-20 S 9741ND, Pipe :— Bolt, 4 BA | 1 | — | C | |
| 28E/9128270 | AGS.2080/10 | Clip, "P" | 1 | — | C | |
| 28W/9419465 | SP.13/B | Washer | 1 | — | C | |
| 10076 | 10-20 S 12169ND | PIPE , between third joint at port side fuselage and stop valve, assembly | 1 | — | C | QF1 QF2 |
| 28D/9137408 | AS.1246/½B | Attachments for 10-20 S 12169ND, Pipe :— Bolt, 4 BA | 1 | — | C | |
| 28E/9128270 | AGS.2080/10 | Clip, "P" | 1 | — | C | |
| 28W/9419465 | SP.13/B | Washer | 1 | — | C | |

SERVICES
ANTI-"G" SYSTEM

| Ref. No. | Part No. | Description | No. off | Material Specification | Class of Store or L.M. | Plate No. |
|-------------|-----------------|---|---------|------------------------|------------------------|------------|
| | | | | | | |
| | — | PIPES , coded No. 2, stop valve to tee union, aft of stn. 131"-10 group (Mod. 358) | 1 | — | — | |
| 13894 | 10-20 S 12631ND | PIPE , between stop valve and first joint, aft of stn. 131"-10 (Pre Mod. 1341) | 1 | — | C | QF1 |
| 18918 | 10-20 S 21381ND | PIPE , between stop valve and first joint, aft of stn. 131"-10 (Mod. 1341) | 1 | — | C | QF2 |
| | | Attachments for 10-20 S 12631ND, or 10-20 S 21381ND, Pipe :— | | | | |
| 28E/9128270 | AGS.2080/10 | Clip, " P " | 1 | — | C | |
| 15823 | 10-20 S 13743ND | PIPE , between first joint from stop valve and second joint (Pre Mod. 1341) | 1 | — | C | QF1 |
| 18919 | 10-20 S 21383ND | PIPE , between first joint from stop valve and second joint (Mod. 1341) | 1 | — | C | QF1 QF2 |
| | | Attachments for 10-20 S 13743ND, or 10-20 S 21383ND, Pipe :— | | | | |
| 28D/9137408 | AS.1246/3B | Bolt, 4 BA | 2 | — | C | |
| 28E/9128270 | AGS.2080/10 | Clip, " P " | 2 | — | C | |
| 28W/9419465 | SP.13/B | Washer | 2 | — | C | |
| 15826 | 10-20 S 13747ND | PIPE , between tee union coupling and first joint, aft of stn. 131"-10, assembly | 1 | — | C | QF1 QF2 |
| | | Attachments for 10-20 S 13747ND, Pipe :— | | | | |
| 28D/9133011 | A25/2C | Bolt, 2 BA | 1 | — | C | |
| 28E/9128270 | AGS.2080/10 | Clip, " P " | 1 | — | C | |
| 28E/9153391 | AGS.2080/16 | Clip, " P " (attached to oxygen pipe) | 1 | — | C | |
| 28M/10288 | AGS.2001/C/1 | Nut | 1 | — | C | |
| 28W/9419402 | SP.13/C | Washer | 1 | — | C | |
| 17306 | 10-20 S 20553ND | PIPE , coded No. 3, between tee union coupling and pilot's anti-"G" valve (Mod. 534) | 1 | — | C | QF1 QF2 |
| | | Attachments for 10-20 S 20553ND, Pipe :— | | | | |
| 28E/9128270 | AGS.2080/10 | Clip, " P " | 1 | — | C | |
| 17305 | 10-20 S 15287ND | PIPE , coded No. 4, between tee union coupling to navigator's anti-"G" valve, assembly (Mod. 534) | 1 | — | C | QF1 QF2 |
| | | Attachments for 10-20 S 15287ND, Pipe :— | | | | |
| 28D/9436920 | A25/1C | Bolt | 1 | — | C | |
| 28E/9128270 | AGS.2080/10 | Clip, " P " | 1 | — | C | |
| 28W/9419402 | SP.13/C | Washer | 1 | — | C | |
| | 10-20 S 11843A | PLATE , " P " clip attachment, pipe coded No. 1, at lower, corner of rear bulkhead, Port, assembly | 1 | — | — | QF1 QF1 |
| 28M/9434253 | AGS.2007/B/1 | NUT , anchor, 4 BA | 2 | — | C | |
| | 10-20 S 11845ND | PLATE , bare, 16 SWG | 1 | L.72 | LM | QF1 QF2 |
| | | Attachments for 10-20 S 11843A, Plate :— | | | | |
| 28D/1007973 | AS.1242/2B | Bolt, 2 BA | 2 | — | C | |
| 28F/12194 | AGS.1119/E | UNION , tee pipe coupling, at inter-connection of pipes code Nos. 2, 3, and 4 | 1 | — | C | QF1 |
| 28F/9476128 | AGS.1112/E | UNION-BODY , flanged bulkhead adapter at stn. 148", Port side of fuselage lower | 1 | — | C | |
| | | Attachments for AGS.1112/E, Union-Body :— | | | | |
| 28D/9133012 | A25/3C | Bolt, 2 BA | 6 | — | C | |
| 28M/10288 | AGS.2001/C/1 | Nut, 2 BA | 6 | — | C | |
| 26FN/3285 | DHS.180 Mk. 3/X | Tag | 2 | — | C | QF2 |
| 28W/9419404 | SP.16/C | Washer | 6 | — | C | |

SERVICES
ANTI-"G" SYSTEM

| Ref. No. | Part No. | Description | No. off | Material Specification | Class of Store or L.M | Plate No. |
|-------------|-------------------|---|---------|------------------------|-----------------------|------------|
| | | | | | | |
| | — | VALVE, anti-"G," pilot's, complete with mounting bracket, on equipment deck forward of stn. 107", installation (Drg. No. 10-20 S 20193) (Mod. 534) | 1 | — | — | QF2 |
| 17310 | 10-20 S 20555 | BRACKET, anti-"G" valve | 1 | — | C | QF2 |
| | | Attachments for 10-20 S 20555, Bracket :— | | | | |
| 28D/9133012 | A25/3C | Bolt, 2 BA | 2 | — | C | |
| 28D/9709461 | AS.1242/3C | Bolt, 2 BA | 1 | — | C | |
| 28M/10288 | AGS.2001/C/1 | Nut, 2 BA | 3 | — | C | |
| 28W/9419404 | SP.16/C | Washer | 3 | — | C | |
| 5K/3417 | AS.3360/B7C | LEAD, bonding, flexible | 1 | — | C | |
| | 10-20 S 20197A | LEVER, test, anti-"G" valve, assembly | 1 | — | — | QF2 |
| 17308 | 10-20 S 20169ND | BRACKET, hinge, 20 SWG | 1 | — | C | QF2 |
| | | Attachments for 10-20 S 20169ND, Bracket :— | | | | |
| 28P/850 | SP.4Y/CB | Pin, shackle | 1 | — | C | |
| 28P/1007741 | SP.9/CB | Pin, split | 1 | — | C | |
| 28E/14138 | AS.486/14 | CLIP, saddle | 1 | — | C | |
| 17309 | 10-20 S 15285A/ND | LEVER, assembly | 1 | — | C | QF2 |
| 17307 | 10-20 S 20159ND | SPRING, 20 SWG | 1 | — | C | QF2 |
| | | Attachments for 10-20 S 20197A, Lever :— | | | | |
| 28D/1011019 | A25/8C | Bolt, 2 BA | 1 | — | C | |
| 28M/10328 | AGS.2002/C/1 | Nut, 2 BA | 1 | — | C | |
| 28W/9419454 | SP.10/C | Washer | 1 | — | C | |
| 27VB/5994 | — | VALVE, anti-"G" (For spares see A.P.4515E, Vol. 3, Part 1) | 1 | — | P | QF1 |
| | | Attachments for Ref. No. 27VB/5994, Valve :— | | | | |
| 5612 | 10-20 S 20157ND | Block, packing, 1"-50 x 1/2"-56 x 1/4"-45 | 1 | L.64 | LM | QF2 |
| 28D/1011006 | A25/1B/DHS.514/D | Bolt, 4 BA | 2 | — | C | |
| 28W/9419401 | A25/5B | Bolt, 4 BA (Lock to DHS.514/D) | 2 | — | C | |
| | SP.10/B | Washer | 4 | — | C | |
| 27VB/5994 | — | VALVE, anti-"G" navigator's, installation (Drg. No. 10-20 S 20199) (Mod. 534) | 1 | — | — | |
| | | VALVE, anti-"G," (For spares see A.P.4515E, Vol. 3, Part 1) | 1 | — | P | QF1 QF2 |
| | | Attachments for Ref. No. 27VB/5994, Valve :— | | | | |
| 28S/1200033 | 10-20 S 20007ND | Block, packing, 1"-25 x 0"-5 x 0"-4 | 2 | L.64 | LM | QF2 |
| 28W/9419474 | A31/B24 | Screw, 4 BA (Lock to DHS.514/D) | 4 | — | C | |
| | SP.16/B | Washer | 4 | — | C | |
| 27VB/5343 | HYMATIC SV.31/3 | VALVE, stop, mounted on top side of Port fuselage between frame stns. 118"-5 and 131"-10 (For spares see A.P.4515E, Vol. 3, Part 1) | 1 | — | P | QF1 QF2 |
| | | Attachments for SV.31/3, Valve :— | | | | |
| 28D/1010030 | A25/7C | Bolt, 2 BA | 2 | — | C | |
| | AS.2811/5/045 | Tube, distance, 1/8" o/d x 17 SWG x 0"-45 long | 2 | L.62 | LM | |

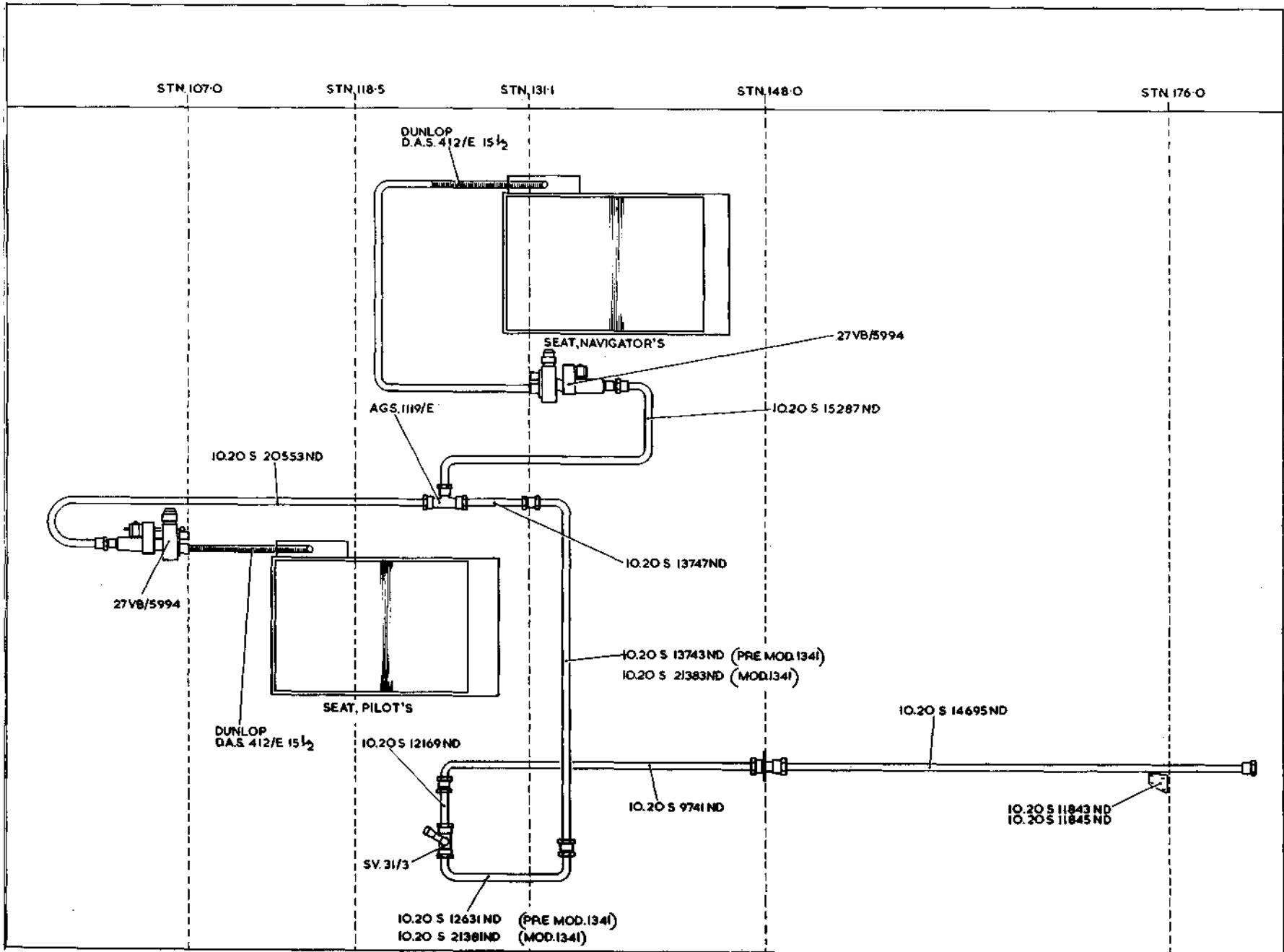

QF.1

SERVICES

QF.1

ANTI-G SYSTEM

RESTRICTED

[A.5g]

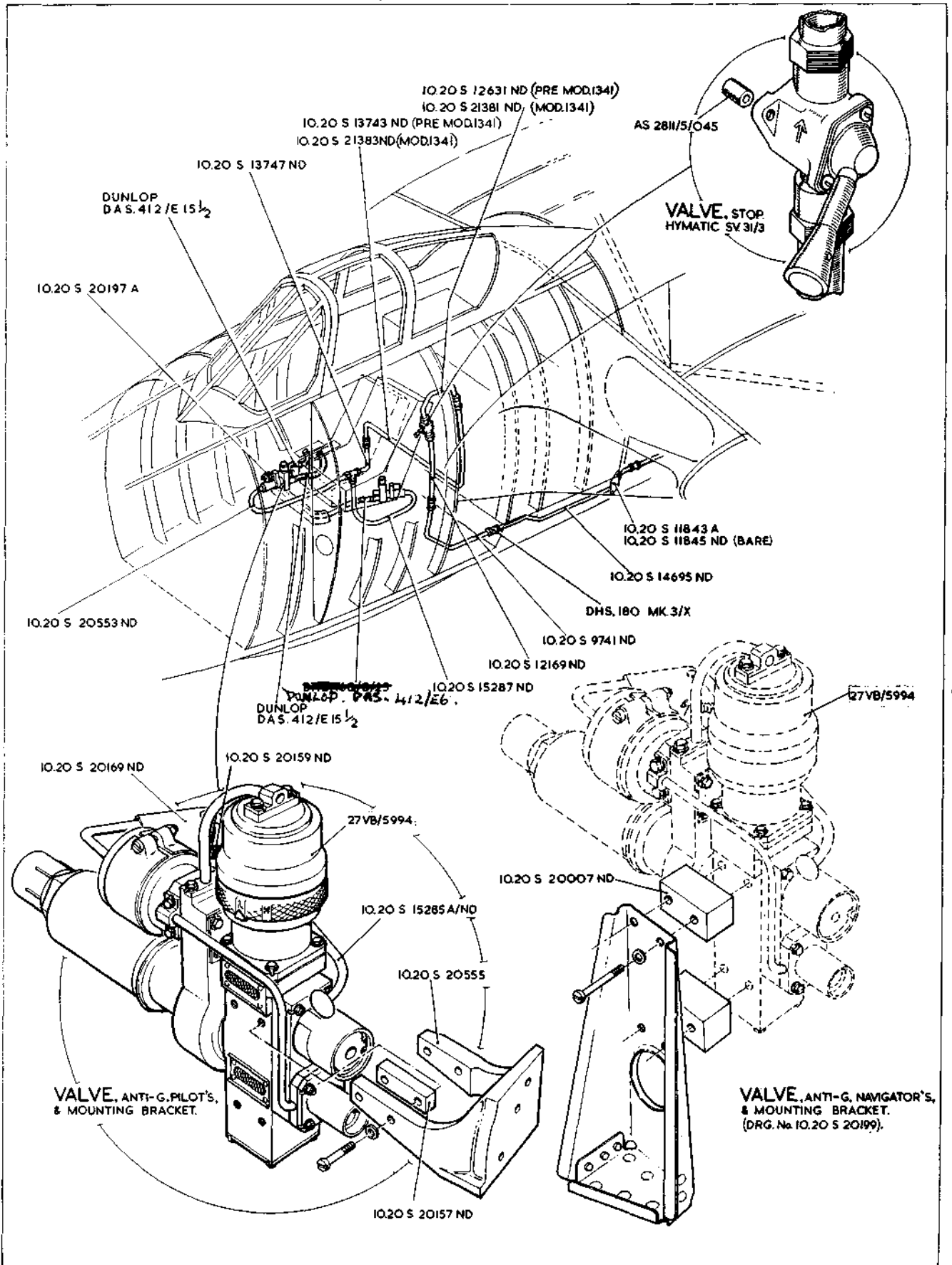

QF.2

SERVICES

ANTI-'G' SYSTEM

QF.2
[AL56]

This file was downloaded
from the RTFM Library:

Link: www.scottbouch.com/rtfm

Please see site for usage terms,
and more aircraft documents.

