

**TAIL UNIT
FIN AND TAIL BOOM**

Ref. No.	Part No.	Description	No. off	Material Specification	Class of Store or L.M.	Place No.
117	S10-20 T 101	FIN AND TAIL BOOM, PORT (Special spares assembly complete with attachments)	1	—	P	
118	S10-20 T 102	FIN AND TAIL BOOM, STARBOARD (Special spares assembly, complete with attachments)	1	—	P	
	—	BUMPER , tail, Port and Starboard, group (Drg. No. 10-20 TB 449)	1	—	—	RC1
86	S10-20 TB 1	FAIRING , underfin (Special spares assembly, complete with attachments)	1	—	P	RC1
	10-20 TB 941A	FAIRING , underfin, assembly	1	—	—	RC1
7158	10-20 TB 983	BLOCK , trailing edge	1	—	C	RC1
	10-20 TB 971	DIAPHRAGM , between main forward and centre formers (For spares use 10-20 TB 1477ND)	1	—	—	RC1
10218	10-20 TB 1477ND	DIAPHRAGM , between main forward and centre formers (Spares condition)	1	—	C	
	10-20 TB 1691A	FORMER , forward longitudinal, between forward edge and main former (For spares use 10-20 TB 1751A/ND)	1	—	—	RC1
14700	10-20 TB 1751A/ND	FORMER , forward longitudinal, between forward edge and main former (Spares condition)	1	—	C	
	10-20 TB 949A	FORMER , main forward, assembly (For spares use 10-20 TB 1445A/ND)	1	—	—	RC1
10214	10-20 TB 1445A/ND	FORMER , main forward, assembly (Spares condition)	1	—	C	
	10-20 TB 973A	FORMER , centre, assembly (For spares use 10-20 TB 1463A/ND)	1	—	—	RC1
10217	10-20 TB 1463A/ND	FORMER , centre, assembly (Spares condition)	1	—	C	
	10-20 TB 977A	FORMER , rear, assembly (For spares use 10-20 TB 1469A/ND)	1	—	—	RC1
10379	10-20 TB 1469A/ND	FORMER , rear, assembly (Spares condition)	1	—	C	
7161	10-20 TB 965	MEMBER , bottom	1	—	C	RC1
		Attachments for 10-20 TB 965, Member :—				
7198	DHS.964/1C	Bolt, 2 BA	1	—	C	RC1
28D/1007982	AS.1248/1C	Bolt, 2 BA	33	—	C	
28D/1013284	AS.1248/2C	Bolt, 2 BA	8	—	C	
28D/9142406	AS.1248/3C	Bolt, 2 BA	2	—	C	
28M/9435067	AGS.2008/C/1	NUT , anchor, 2 BA	26	—	C	
	10-20 TB 963	RIB , top (For spares use 10-20 TB 1455ND)	1	—	—	RC1
10216	10-20 TB 1455ND	RIB , top (Spares condition)	1	—	C	
	10-20 TB 1035A/ND	SKIN and doubler, L.H., assembly (For spares use 10-20 TB 1521A/ND)	1	—	—	RC1
12169	10-20 TB 1521A/ND	SKIN and doubler, L.H., assembly (Spares condition)	1	—	C	

**TAIL UNIT
FIN AND TAIL BOOM**

Ref. No.	Part No.	Description						No. off	Material Specification	Class of Store or L.M.	Plate No.
		1	2	3	4	5	6				
	10-20 TB 1036A/ND							1	—	—	RC1
12170	10-20 TB 1522A/ND							1	—	C	
	10-20 TB 947A							1	—	—	RC1
10213	10-20 TB 1441A/ND							1	—	C	
	10-20 TB 967A							1	—	—	RC1
10380	10-20 TB 1457A/ND							1	—	C	
	10-20 TB 968A							1	—	—	RC1
10381	10-20 TB 1458A/ND							1	—	C	
	10-20 TB 1743A							1	—	—	RC1
15757	10-20 TB 2153A/ND							1	—	C	
	10-20 TB 1744A							1	—	—	RC1
15758	10-20 TB 2154A/ND							1	—	C	
	10-20 TB 961ND							1	L.72	—	RC1
28D/9436920	A25/1C							4	—	C	
28D/9133011	A25/2C							4	—	C	
28D/1200119	A25/4C							4	—	C	
28D/12473	AS.1248/4E							2	—	C	
28D/12135	AS.1248/5E							2	—	C	
28D/10473	AS.1248/6E							2	—	C	
28D/9554	AS.1248/7E							4	—	C	
1092	DHS.365/2C							2	—	C	RC1
4371	DHS.365/2½C							16	—	C	RC1
2729	DHS.365/3¼C							8	—	C	RC1

TAIL UNIT
FIN AND TAIL BOOM

Ref. No.	Part No.	Description	No. off	Material Specification	Class of Store or L.M	Plate No.
2742	DHS.365/4C	Bolt, 2 BA	8	—	C	RC1
4161	DHS.365/4C	Bolt, 2 BA	16	—	C	RC1
28M/9403520	A27/CP	Nut, 2 BA	4	—	C	
28M/10288	AGS.2001/C/1	Nut, 2 BA	4	—	C	
28M/10328	AGS.2002/C/1	Nut, 2 BA	42	—	C	
28M/10290	AGS.2001/E/1	Nut, 1/2" BSF	8	—	C	
28M/7002430	AGS.2002/E/1	Nut, 1/2" BSF	2	—	C	
17114	10-20 TB 2201ND	Packing, between underfin fairing and joint casting	2	—	C	RC1
	10-20 TB 1335ND	Packing, tapered, reinforcing strip, L.H.	1	L.16	—	RC1
	10-20 TB 1336ND	Packing, tapered, reinforcing strip, R.H.	1	L.16	—	RC1
28W/9419402	SP.13/C	Washer	8	—	C	
28W/7000392	SP.14/E	Washer	10	—	C	
28W/9419475	SP.15/C	Washer	46	—	C	
7964	S10-20 TB 3	SHOE-SKID (Special spares assembly complete with attachments)	1	—	P	RC1
	10-20 TB 1783A	SHOE-SKID , assembly (Mod. 724)	1	—	—	RC1
	10-20 TB 1817A	ARM , radius, assembly (Mod. 724)	1	—	—	RC1
4440	10-20 TB 683	BUSH , at pivot bolt holes (For oversize replacement see Repair section PA)	2	—	C	RC1
4441	10-20 TB 685	BUSH , at shock absorber strut bolt holes (For oversize replacement see Repair section PA)	2	—	C	RC1
28M/9435560	AGS.2007/E/1	NUT , anchor, 1/2" BSF	6	—	C	
15308	10-20 TB 1763A	FAIRING , shoe-skid, assembly	1	—	C	RC1
28D/1013179	AS.1242/6E	Attachments for 10-20 TB 1763A, Fairing :—	6	—	C	
4439	10-20 TB 541	Bolt , 2 BA	6	—	C	
		SHOE	1	—	C	RC1
		Attachments for 10-20 TB 541, Shoe :—				
28D/1013178	AS.1242/5E	Bolt , 1/2" BSF	2	—	C	
28M/10290	AGS.2001/E/1	Nut , 1/2" BSF	2	—	C	
28W/9419405	SP.15/E	Washer	2	—	C	
15307	10-20 TB 1765ND	STRIP , rubbing, 14 SWG	1	—	C	RC1
		Attachments for 10-20 TB 1765ND, Strip :—				
28D/1218444	AS.1242/1E	Bolt , 1/2" BSF	1	—	C	
28D/1212825	AS.1242/4E	Bolt , 1/2" BSF	5	—	C	
28M/10290	AGS.2001/E/1	Nut , 1/2" BSF	5	—	C	
28W/9419405	SP.15/E	Washer	5	—	C	
		Attachments for 10-20 TB 1783A, Shoe-Skid :—				
4443	10-20 TB 441	Bolt , special, pivot	1	—	C	RC1
18878	10-20 TB 5039A	Bolt , special, at shock absorber strut (Mod. 1182)	1	—	C	RC1
4444	10-20 TB 445	Nut , at pivot bolt	1	—	C	RC1
28M/1011476	A27/JS	Nut , 3/8" BSF	1	—	C	
28P/9527619	SP.90/C7	Pin , split (SP.9/C8)	1	—	C	
4445	10-20 TB 443	Washer , locking, at pivot bolt	1	—	C	RC1
4578	DHS.781/46/18	Washer	1	—	C	RC1
88	S10-20 TB 2	STRUT , shock absorber (Special spares assembly complete with attachments)	1	—	P	
27M/970	LOCKHEED AIR.47060	STRUT , shock absorber (For spares see AP.4515F, Vol. 3, Pt. 1, Sect. 2, Chap. 23)	1	—	P	RC1
		Attachments for AIR.47060, Strut :—				
4446	10-20 TF 1319	Bolt , special, top attachment	1	—	C	RC1
18878	10-20 TB 5039A	Bolt , special, bottom attachment, assembly (Mod. 1182)	1	—	C	RC1
28M/1011476	A27/JS	Nut , 3/8" BSF	2	—	C	
28P/9527619	SP.90/C7	Pin , split (SP.9/C8)	2	—	C	
4447	10-20 TF 1321	Spacer , top attachment bolt	1	—	C	RC1
4578	DHS.781/46/18	Washer , bottom attachment bolt	1	—	C	RC1

**TAIL UNIT
FIN AND TAIL BOOM**

Ref. No.	Part No.	Description	No. off	Material Specification	Class of Store or LM	Plate No.
—	—	<p>CONTROLS (See sub-section CB)</p> <p>Note :—The Fin and Tail Boom spares assembly is supplied complete with all Controls except for the following items :—</p> <p>(Fin and Tail Boom, Port and Starboard) :—Rudder booster, Tailplane booster, Tailplane actuating link, Elevator operating area and connector rod, Elevator position warning micro-switch, coded "UP" Port, "ZP" Starboard</p> <p>(Fin and Tail Boom, Port) :—Rudder yaw damper, Tailplane mach sensitive gearchange actuator, coded "UM," Tailplane trim actuator, coded "UJ," Tailplane position indicator transmitter, coded "UH," Tailplane trim actuator solenoid, coded "UK," Tailplane trim actuator micro-switch coded "UY "</p> <p>(Fin and Tail Boom, Starboard) :—Rudder trim actuator, coded "ZJ," Rudder position transmitter, coded "ZW "</p>	—	—	—	
—	—	<p>ELECTRICAL COMPONENTS (See appropriate Electrical sub-sections)</p> <p>Note :—The following components are not fitted to the Fin and Tail Boom Spares assemblies :—</p> <p>Control panel, Type 15, coded "UD" Port, "ZC" Starboard</p> <p>Control panel, Type 26B, coded "UX" Port, "ZF" Starboard</p> <p>Starter Units, coded "UZ" and "UC" Port, "ZD" and "ZG" Starboard</p> <p>Starter unit relays, coded "VF" and "UE" Port, "ZL" and "ZK" Starboard, Inverter Type 103, coded "UB" Port, "ZB" Starboard, Inverter Type 112, coded "UT" Port, Inverter Type 108, coded "ZE" Starboard</p> <p>Relay and condenser box, coded "UF" Port</p>	—	—	—	

**TAIL UNIT
FIN AND TAIL BOOM**

Ref. No.	Part No.	Description	No. off	Material Specification	Class of Score or L.M	Plate No.
	10-20 TF 1943	FIN, PORT, ASSEMBLY (Mod. 650)	1	—	—	RC2
	10-20 TF 1945	FIN, STARBOARD, ASSEMBLY (Mod. 650)	1	—	—	RC2
	10-20 TF 1263	Spares for :— ANGLE , at pivot connection and lower diaphragm (fin head assembly to fin structure), Port	1	L.65	—	RC2 RC4
	10-20 TF 1264	ANGLE , at pivot connection and lower diaphragm (fin head assembly to fin structure), Starboard	1	L.65	—	RC2 RC4
		Attachments for 10-20 TF 1263 or 10-20 TF 1264, Angles :—				
28D/9133011	A25/2C	Bolt, 2 BA	6	—	C	
28D/9133012	A25/3C	Bolt, 2 BA	5	—	C	
2727	DHS.901/2E	Bolt, 1/4" BSF	4	—	C	RC4
2364	DHS.901/2 1/2 E	Bolt, 1/4" BSF	2	—	C	RC4
2732	DHS.901/3E	Bolt, 1/4" BSF	6	—	C	RC4
1653	DHS.365/2E	Bolt, 1/4" BSF	3	—	C	RC4
1657	DHS.365/3E	Bolt, 1/4" BSF	7	—	C	RC4
28M/9403520	A27/CP	Nut, 2 BA	11	—	C	
28M/1011475	A27/EP	Nut, 1/4" BSF	10	—	C	
2227	DHS.983/E	Nut, 1/4" BSF	8	—	C	RC4
28W/9419405	SP.15/E	Washer	8	—	C	
	10-20 TF 1463	Washer, support, 0"-66 x 0"-6 x 12 SWG	1	L.72	LM	RC4
	10-20 TF 1461	Washer, support, 0"-73 x 0"-6 x 12 SWG	1	L.72	LM	RC4
1092	DHS.365/2C	BOLT , 2 BA, attachment, at fin head joint Attachments for DHS.365/2C, Bolt :—	5	—	C	RC2
28M/9403520	A27/CP	Nut, 2 BA	5	—	C	
28W/9419475	SP.15/C	Washer	5	—	C	
1792	DHS.365/3C	BOLT , 2 BA, at intersection of fin rib No. 10 and stringer "A"	4	—	C	RC9
1092	DHS.365/2C	BOLT , 2 BA, attachment at intersection of fin diaphragm and stringer "D," inboard and outboard and at junction of fin diaphragm and false spar, inboard	6	—	C	RC9
		Attachments for DHS.365/2C, Bolt :—				
28M/1010996	A24/CP	Nut, 2 BA	1	—	C	
28M/10288	AGS.2001/C/1	Nut, 2 BA	1	—	C	
28W/9419402	SP.13/C	Washer	1	—	C	
1790	DHS.726/C16	Washer, support	1	—	C	RC9
1092	DHS.365/2C	BOLT , 2 BA, for skin attachment, outer, fin joint to boom	30	—	C	RC9
4371	DHS.365/2 1/2 C	BOLT , 2 BA, for skin attachment, outer, fin joint to boom	18	—	C	RC9
2729	DHS.365/3 1/2 C	BOLT , 2 BA, for skin attachment, outer, fin joint to boom	23	—	C	RC9
2742	DHS.365/4C	BOLT , 2 BA, for skin attachment, outer, fin joint to boom	4	—	C	RC9
		Attachments for DHS.365/2C, DHS.365/2 1/2 C, DHS.365/3 1/2 C or DHS.365/4C, Bolt :—				
28M/10288	AGS.2001/C/1	Nut, 2 BA	1	—	C	
28W/9419475	SP.15/C	Washer	1	—	C	

**TAIL UNIT
FIN AND TAIL BOOM**

Ref. No.	Part No.	Description	No of	Material Specification	Class of Store or L.M.	Plate No.
1792	DHS.365/3C	BOLT , 2 BA, reinforcement, inner and outer skins at head of fin spar	16	—	C	RC7
2742	DHS.365/4C	BOLT , 2 BA, reinforcement, inner and outer skins at head of fin spar	12	—	C	EC7
28M/1010996	A24/CP	Attachments for DHS.365/3C or DHS.365/4C, Bolt :— Nut, 2 BA	1	—	C	
	10-20 TF 649	BRACKET , angle attachment for cover plate, reinforcing, between stringers "B" and "C" at rib No. 8, 18 SWG	2	L.72	—	
7478	10-20 TF 555	BRACKET , angle, for fairing attachment, 16 SWG Attachments for 10-20 TF 555, Bracket :—	1	—	C	
28D/1200119	A25/4C	Bolt, 2 BA	1	—	C	
28D/9133013	A25/5C	Bolt, 2 BA	2	—	C	
28W/9419475	SP.15/C	Washer	3	—	C	
	10-20 TF 1637A	BRACKET , cable attachment, assembly Spares for :—	4	—	LM	RC4
28M/9434251	AGS.2008/B1	NUT , anchor, 4 BA	1	—	C	
6338	10-20 TF 1669A	BRACKET , hinge, for rudder, bottom, assembly Spares for :—	1	—	P	RC2
6412	10-20 TF 611	BUSH (See Repair Section PA)	2	—	C	RC2
1623	10 TF 2181ND	SHIM , washer	2	—	C	RC2
26FN/3002	A25/5E/DHS.514/D	Attachments for 10-20 TF 1669A, Bracket :— Bolt, 1/2" BSF (Alternative S21.A25/5E)	4	—	C	
26FN/3275	DHS.69/DD	Shim, 0"-26 1/d x 1/8" thick x 0"-6 o/d	4	—	C	RC2
17629	10-20 TF 4119A	BRACKET , hinge, for rudder centre, assembly (Mod. 1225) Spares for :—	1	—	P	RC2
26FN/3557	RANSOME & MARLES CN/8	BEARING , ball Attachments for CN/B, Bearing :—	1	—	C	RC2
28N/9488443	AGS.2030/31	Circlip	1	—	C	
9810	10-20 TF 919	Washer, split, 22 SWG	2	—	C	RC2
2A/9500149	BAL.010	BEARING , ball (3110-99-950-0149) Attachments for 10-20 TF 4119A, Bracket :—	1	—	C	RC2
28D/1213764	A30/6E	Bolt, 1/2" BSF	4	—	C	
28M/1011475	A27/EP	Nut, 1/2" BSF	4	—	C	
6340	10-20 TF 1677A	BRACKET , hinge for rudder, top, assembly Spares for :—	1	—	P	RC2
6412	10-20 TF 611	BUSH (See Repair Section PA)	2	—	C	RC2
1623	10 TF 2181ND	SHIM , washer	2	—	C	RC2
28D/1008145	A25/6E	Attachments for 10-20 TF 1677A, Bracket :— Bolt, 1/2" BSF	4	—	C	
28M/13266	A24/ES	Nut, 1/2" BSF	4	—	C	
28P/9527619	SP.90/C7	Pin, split (SP.9/C8)	4	—	C	
1629	10 TF 2079	Shim, 1"-8 x 0"-9 x 0"-06 thick, "Attewell"	2	—	C	RC2

TAIL UNIT
FIN AND TAIL BOOM

Ref. No.	Part No.	Description	No. off	Material Specification	Class of Score or L.M	Plate No.
1624	10-20 TF 1167A	BRACKET , lower booster pick-up at fin rib No. 11, Port, assembly	1	—	P	RC2
1625	10-20 TF 1168A	BRACKET , lower booster pick-up at fin rib No. 11, Starboard, assembly	1	—	P	RC2
1626	10 TF 1233	BUSH , in lower booster pick-up (See Repair Section PA)	2	—	C	RC2
		Attachments for 10-20 TF 1167A or 10-20 TF 1168A, Bracket (to diaphragm) :—				
28D/1214288	A30/2C	Bolt, 2 BA	8	—	C	
28M/1010996	A24/CP	Nut, 2 BA	8	—	C	
	10-20 TF 1995ND	Shim, inboard (if required) (Mod. 838) "Attewell"	1	LA.3	—	RC2
	10-20 TF 1997ND	Shim, outboard (if required) (Mod. 838) "Attewell"	1	LA.3	—	RC2
28W/9419402	SP.13/C	Washer	8	—	C	
		Attachments for 10-20 TF 1167A or 10-20 TF 1168A, Bracket (to skin) :—				
1792	DHS.365/3C	Bolt, 2 BA (Starboard only)	1	—	C	RC2
2742	DHS.365/4C	Bolt, 2 BA (Lock to DHS.514/D)	103	—	C	RC2
4161	DHS.365/4½C	Bolt, 2 BA (Lock to DHS.514/D)	8	—	C	RC2
28M/1010996	A24/CP	Nut, 2 BA	103	—	C	
28M/1010997	A24/CT	Nut, 2 BA (Starboard only)	1	—	C	
28M/10288	AGS.2001/C/1	Nut, 2 BA (inboard side only)	9	—	C	
28W/9419402	SP.13/C	Washer	102	—	C	
	10-20 TF 1777ND	Washer, special, tapered, 0"50 × 0"50 × 14 SWG	8	L.72	LM	RC2
	10-20 CF 4195A	BRACKET , pulley, flying control cables, between fin stringers "C" and "D," Port, assembly	1	—	—	RC2 RC4
	10-20 CF 4196A	BRACKET , pulley, flying control cables, between fin stringers "C" and "D," Starboard, assembly	1	—	—	RC2 RC4
5863	10-20 CF 7347A/ND	BRACKET , pulley, complete with bush and wire thread insert, Port, assembly	1	—	C	RC4
5864	10-20 CF 7348A/ND	BRACKET , pulley, complete with bush and wire thread insert, Starboard, assembly	1	—	C	RC4
		Spare for :—				
4792	10-20 CF 2363	PIN , cable guard	2	—	C	RC4
2971	DHS.790	PULLEY , 4"0 dia., assembly	1	—	C	RC4
		Spare for :—				
2A/9501471	SKEFKO 401458	BEARING , ball (3110-99-950-1471)	1	—	C	RC4
2969	DHS.793	PLATE , retaining	1	—	C	RC4
		Attachments for DHS.793, Plate :—				
28D/9709461	AS.1242/3C	Bolt, 2 BA	3	—	C	
28M/1006473	A27/CT	Nut, 2 BA	3	—	C	
		Attachments for DHS.790, Pulley :—				
28M/1007404	A27/JT	Nut, ¾" BSF, stud retaining	1	—	C	
28M/1011476	A27/JS	Nut, ¾" BSF	1	—	C	
28P/9527619	SP.90/67	Pin, split (SP.9/C8)	1	—	C	
	10-20 CF 4199	Strut, special, pulley spindle threaded ¾" BSF	1	5.96	—	RC4
	10 S 4459	BRACKET , support, rudder booster hoses, Port	1	L.72	—	RC4
	10 S 4460	BRACKET , support, rudder booster hoses, Starboard	1	L.72	—	RC4

**TAIL UNIT
FIN AND TAIL BOOM**

Ref. No.	Part No	Description	No of	Material Specification	Class of Store or L.M	Plate No.
	10 TF 1323	CAPPING , fin stringer, L.H., 18 SWG (For spares use 10-20 TF 1957ND)	1	L.73	—	RC2
15093	10-20 TF 1957ND	CAPPING , fin stringer, L.H., 18 SWG (Spares condition)	1	—	C	
	10 TF 1326	CAPPING , fin stringer, L.H., 18 SWG (For spares use 10-20 TF 1960ND)	1	L.73	—	RC2
15096	10-20 TF 1960ND	CAPPING , fin stringer, L.H., 18 SWG (Spares condition)	1	—	C	
	10 TF 1327	CAPPING , fin stringer, L.H., 18 SWG (For spares use 10-20 TF 1961ND)	1	L.72	—	RC2
15097	10-20 TF 1961ND	CAPPING , fin stringer, L.H., 18 SWG (Spares condition)	1	—	C	
	10-20 TF 1324	CAPPING , fin stringer, R.H., 18 SWG (For spares use 10-20 TF 1959ND)	1	L.73	—	RC2
15094	10-20 TF 1959ND	CAPPING , fin stringer, R.H., 18 SWG (Spares condition)	1	—	C	
	10 TF 1325	CAPPING , fin stringer, R.H., 18 SWG (For spares use 10-20 TF 1959ND)	1	L.73	—	RC2
15095	10-20 TF 1959ND	CAPPING , fin stringer, R.H., 18 SWG (Spares condition)	1	—	C	
	10 TF 1328	CAPPING , fin stringer, R.H., 18 SWG (For spares use 10-20 TF 1962ND)	1	L.73	—	RC2
15098	10-20 TF 1962ND	CAPPING , fin stringer, R.H., 18 SWG (Spares condition)	1	—	C	
	10 TF 1329	CAPPING , stringer, at head of stringer "D," Port, 18 SWG (For spares use 10-20 TF 1963ND)	1	L.73	—	RC2
15099	10-20 TF 1963ND	CAPPING , stringer, at head of stringer "D," Port, 18 SWG (Spares condition)	1	—	C	
	10 TF 1330	CAPPING , stringer, at head of stringer "D," Starboard, 18 SWG (For spares use 10-20 TF 1964ND)	1	L.73	—	RC2
15100	10-20 TF 1964ND	CAPPING , stringer, at head of stringer "D," Starboard, 18 SWG (Spares condition)	1	—	C	
	10 TB 487	CAPPING , stringer "B," L.H., 18 SWG (4 off Port, 2 off Starboard) (For spares use 10-20 TB 1733ND)	6	L.72	—	RC2
14593	10-20 TB 1733ND	CAPPING , stringer "B," L.H., 18 SWG (4 off Port, 2 off Starboard) (Spares condition)	6	—	C	
	10 TB 488	CAPPING , stringer "B," R.H., 18 SWG (4 off Port, 2 off Starboard) (For spares use 10-20 TB 1734ND)	6	L.72	—	RC2
14594	10-20 TB 1734ND	CAPPING , stringer "B," R.H., 18 SWG (4 off Port, 2 off Starboard) (Spares condition)	6	—	C	
	10 TB 297	CAPPING , stringer "C," L.H., 18 SWG	1	L.72	—	RC2
	10 TB 298	CAPPING , stringer "C," R.H., 18 SWG	1	L.72	—	RC2
	10 TF 1787	CAPPING , stringer "D," L.H., 18 SWG	1	L.72	—	RC2
	10 TF 1788	CAPPING , stringer "D," R.H., 18 SWG	1	L.72	—	RC2
	10-20 TF 1533A	CHANNEL , bridge, between joint rib and fin rib No. 8, inboard, Port, assembly	1	—	—	RC2
	10-20 TF 1534A	CHANNEL , bridge, between joint rib and fin rib No. 8, inboard, Starboard, assembly	1	—	—	RC2
	10 TF 1837	ANGLE , 18 SWG	2	L.72	LM	RC2
28M/10229	AGS.2009/C/1	NUT , 2 BA, anchor	10	—	C	
	10-20 TF 1537ND	PACKING , 18 SWG	1	L.72	LM	RC2
	10-20 TF 1538ND	PACKING , 18 SWG	1	L.72	LM	RC2

**TAIL UNIT
FIN AND TAIL BOOM**

Ref. No.	Part No.	Description	No. off	Material Specification	Class of Store or L.M	Plate No.	
							1
7479	10 TF 1805	CHANNEL , L.H., between stringers "C" and "D," outer skin, Port	1	—	C	RC5	
7480	10 TF 1806	CHANNEL , R.H., between stringers "C" and "D," outer skin, Starboard	1	—	C	RC5	
15445	10-20 TF 1907A	COVER , access, auto-stabilizer trim actuator, Port, assembly (Mod. 737)	1	—	C	RC6	
	OR						
17437	10-20 TF 2031A	COVER , access, auto-stabilizer trim actuator, Port, assembly	1	—	C	RC6	
15446	10-20 TF 1908A	COVER , access, auto-stabilizer trim actuator, Starboard, assembly (Mod. 737)	1	—	C	RC6	
	OR						
17438	10-20 TF 2032A	COVER , access, auto-stabilizer trim actuator, Starboard, assembly	1	—	C	RC6	
		Attachments for 10-20 TF 1907A, 10-20 TF 1908A, 10-20 TF 2031A or 10-20 TF 2032A, Cover :—					
28D/8307	AS.1242/2C	Bolt, 2 BA	21	—	C		
15447	10-20 TF 1887	Bolt, special (Mod. 737)	1	—	C	RC6	
	10-20 TF 1783	COVER , access, hydraulic hose connections at rudder booster, outer skin, Port and Starboard, 16 SWG	1	L.72	LM	RC6	
		Attachments for 10-20 TF 1783, Cover :—					
28D/1007975	AS.1242/1C	Bolt, 2 BA	14	—	C		
	10-20 TF 1785	COVER , access, hydraulic hose connections, at rudder booster, outer skin, Port and Starboard, 16 SWG	1	L.73	LM	RC6	
		Attachments for 10-20 TF 1785, Cover :—					
28D/1007975	AS.1242/1C	Bolt, 2 BA	16	—	C		
	15444	10-20 TF 1903A	COVER , access, hydraulic hose and pipe connections, tail plane booster, outer skin, Port, assembly (Mod. 737)	1	—	C	RC6
		Attachments for 10-20 TF 1903A, Cover :—					
28D/1007975	AS.1242/1C	Bolt, 2 BA	23	—	C		
9144	10-20 TF 969	Bolt, special, 2 BA	3	—	C	RC6	
	1567	10 TF 1478A	COVER , access, hydraulic hose and pipe connections, tail plane booster, outer skin, Starboard, assembly	1	—	C	RC6
		Attachments for 10 TF 1478A, Cover :—					
28D/1007975	AS.1242/1C	Bolt, 2 BA	30	—	C		
	1571	10 TF 1807A	COVER , access, hydraulic pipes between fin ribs Nos. 8 and 9, inner skin, Port, assembly	1	—	C	RC6
		Attachments for 10 TF 1807A, Cover :—					
28D/8307	AS.1242/2C	Bolt, 2 BA	14	—	C		

**TAIL UNIT
FIN AND TAIL BOOM**

Ref. No.	Part No.	Description	No. off	Material Specification	Class of Store or L.M.	Plate No.
9141	10-20 TF 873A	COVER , access, hydraulic pipe connections and auto-pilot cables, also tail plane booster, inner skin, Port, assembly	1	—	C	RC6
28D/8307	AS.1242/2C	Attachments for 10-20 TF 873A, Cover :—				
9144	10-20 TF 969	Bolt, 2 BA	19	—	C	
		Bolt, special, 2 BA	4	—	C	RC6
1569	10 TF 2092	COVER , access, hydraulic pipe connections, tail plane booster, inner skin, Starboard, assembly	1	—	C	RC6
		Attachments for 10 TF 2092, Cover :—				
28D/8307	AS.1242/2C	Bolt, 2 BA	25	—	C	
1582	10 TF 1423	COVER , access, jack-head, tail plane booster, outer skin, Port and Starboard	1	—	C	RC6
		Attachments for 10 TF 1423, Cover :—				
28D/1007975	AS.1242/1C	Bolt, 2 BA	10	—	C	
1572	10 TF 1529A	COVER , access, junction terminal blocks for electric cables to trim actuator and elevator lock micro switch, inner and outer skins, Port and Starboard, assembly	2	—	C	RC6
		Attachments for 10-20 TF 1529A, Cover :—				
28D/8307	AS.1242/2C	Bolt, 2 BA	20	—	C	
1580	10 TF 1425	COVER , access, micro switch, outer skin, Port and Starboard	1	—	C	RC6
		Attachments for 10 TF 1425, Cover :—				
28D/1007975	AS.1242/1C	Bolt, 2 BA	4	—	C	
1588	10 TF 1456	COVER , access, pivot bolt assembly, cable inter-connection compensator, inner skin, Starboard fin only	1	—	C	RC6
		Attachments for 10 TF 1456, Cover :—				
28D/1007975	AS.1242/1C	Bolt, 2 BA	4	—	C	
1605	10-20 TF 1143	COVER , access, pivot bolt, tail plane mach. sensitive gear change, inner and outer skins, Port fin only	2	—	C	RC6
		Attachments for 10-20 TF 1143, Cover :—				
28D/8307	AS.1242/2C	Bolt, 2 BA	6	—	C	
1583	10-20 TF 271	COVER , access, rudder control booster-mounting beam and auto-pilot cable assembly, inner skin, Port and Starboard	1	—	C	RC6
		Attachments for 10-20 TF 271, Cover :—				
28D/8307	AS.1242/2C	Bolt, 2 BA	20	—	C	
6337	10-20 TF 559	COVER , access, tail plane booster rod head, inner and outer skins, Port and Starboard	2	—	C	RC6
		Attachments for 10-20 TF 559, Cover :—				
28D/1007975	AS.1242/1C	Bolt, 2 BA	5	—	C	

**TAIL UNIT
FIN AND TAIL BOOM**

Ref. No.	Part No.	Description	No. off						Material Specification	Class of Store or L.M.	Place No.	
			1	2	3	4	5	6				
1584	10-20 TF 1073	COVER , access, tail plane cable and chain adjustment, outer skin, Port and Starboard							1	—	C	RC6
28D/1007975	AS.1242/1C	Attachments for 10-20 TF 1073, Cover :— Bolt, 2 BA							4	—	C	
11494	10-20 TF 1695A	COVER , access, tail plane inter-connection cable compensator and potentiometer, outer skin, Starboard, assembly							1	—	C	RC6
28D/1007975	AS.1242/1C	Attachments for 10-20 TF 1695A, Cover :— Bolt, 2 BA							36	—	C	
18342	10-20 TF 2049	COVER , access, tail plane phase 2 control unit, Port (Mod. 1297)							1	—	C	RC6
28D/8307	AS.1242/2C	Attachments for 10-20 TF 2039, Cover :— Bolt, 2 BA							23	—	C	
28D/8308	AS.1242/3C	Bolt, 2 BA							2	—	C	
28D/1007976	AS.1242/4C	Bolt, 2 BA							8	—	C	
16779	10-20 TF 2005	Screw, 2 BA							51	—	C	RC6
18343	10-20 TF 2037	Screw, 2 BA							4	—	C	RC6
1585	10-20 TF 383	COVER , access, tail plane pivot, Port							1	—	C	RC6
1586	10-20 TF 384	COVER , access, tail plane pivot, Starboard							1	—	C	RC6
28D/8308	AS.1242/3C	Attachments for 10-20 TF 383 or 10-20 TF 384, Cover :— Bolt, 2 BA							9	—	C	
1575	10-20 TF 7A	COVER , access, trim actuator, inner skin, Port, assembly							1	—	C	RC6
28D/1007975	AS.1242/1C	Attachments for 10-20 TF 7A, Cover :— Bolt, 2 BA							33	—	C	
28D/8307	AS.1242/2C	Bolt, 2 BA							1	—	C	
28D/8322	AS.1242/1E	Bolt, 1/4" BSF							1	—	C	
15448	10-20 TF 1901	COVER , access, trim unit, inner skin, Port (Mod. 737)							1	—	C	RC6
28D/1007975	AS.1242/1C	Attachments for 10-20 TF 1901, Cover :— Bolt, 2 BA							11	—	C	
28D/8307	AS.1242/2C	Bolt, 2 BA							2	—	C	
28D/8308	AS.1242/3C	Bolt, 2 BA							13	—	C	
15449	10-20 TF 1885	Bolt, special (Mod. 737)							1	—	C	RC6
1576	10-20 TF 1179A	COVER , panel, access, tail plane booster, Port, assembly							1	—	P	RC6
1577	10-20 TF 1180A	COVER , panel, access, tail plane booster, Starboard, assembly							1	—	P	RC6
		Spares for :—										
	10-20 TF 1189ND	PLATE , dished, Port, 18 SWG							1	L.73	—	RC6
	10-20 TF 1190ND	PLATE , dished, Starboard, 18 SWG							1	L.73	—	RC6
	10-20 TF 1187ND	RING , reinforcing at flange of panel, between inner plate and outer skin, 18 SWG							1	L.73	—	RC6
	10 TF 1753ND	STIFFENER , across panel, between inner plate and outer skin							1	L.72	—	RC6

**TAIL UNIT
FIN AND TAIL BOOM**

Ref. No.	Part No.	Description	No. off	Material Specification	Class of Score or L.M.	Plate No.
	10 TF 1755ND	STIFFENER , across panel, between inner plate and outer skin, 6"2 long x 20 SWG	1	L.72	—	RC6
	10 TF 1757ND	STIFFENER , across panel, between inner plate and outer skin, 6"45 long x 20 SWG	1	L.72	—	RC6
	10 TF 1759ND	STIFFENER , across panel, between inner plate and outer skin, 6"60 long x 20 SWG	1	L.72	—	RC6
		Attachments for 10-20 TF 1179A or 10-20 TF 1180A, Cover :—				
28D/8324	AS.1242/3E	Bolt, 1/2" BSF	11	—	C	
28D/8325	AS.1242/4E	Bolt, 1/2" BSF	10	—	C	
	10-20 TF 1895A	COVER , panel, detachable, assembly (Mod. 737) (For spares use 10-20 TF 1985A/ND)	1	—	—	RC5 RC6
15451	10-20 TF 1985A/ND	COVER , panel, detachable, assembly (Spares condition)	1	—	C	
		Attachments for 10-20 TF 1895A, Cover :—				
9144	10-20 TF 969	Bolt	2	—	C	RC5
15450	10-20 TF 1889	Bolt	2	—	C	RC5
28D/8307	AS.1242/2C	Bolt, 2 BA	32	—	C	
28D/8308	AS.1242/3C	Bolt, 2 BA	12	—	C	
28D/1013177	AS.1242/2E	Bolt, 1/2" BSF	10	—	C	
28M/9993192	AGS.2009/C/1	Nut, anchor, 2 BA	40	—	C	
28M/9435068	AGS.2008/E/1	Nut, anchor, 1/2" BSF	3	—	C	
28M/10230	AGS.2009/E/1	Nut, anchor, 1/2" BSF	7	—	C	
28E/14072	AS.3181/10B	CLIP , "P." securing pipes at fin nose rib	2	—	C	
		Attachments for AS.3181/10B, Clip :—				
28D/1010658	A25/1B	Bolt, 4 BA	1	—	C	
28M/10287	AGS.2001/B/1	Nut, 4 BA	1	—	C	
28W/9419474	SP.15/B	Washer	1	—	C	
	10-20 TF 1457A	DIAPHRAGM , fin, forward, assembly	1	—	—	RC5
		Spares for :—				
28M/9435067	AGS.2008/C/1	NUT , 2 BA, anchor	5	—	C	
8003	10-20 TF 625	FAIRLEAD , control cables on main fin rib, centre, 3/16" thick	1	—	C	RC2
		Attachments for 10-20 TF 625, Fairlead :—				
28D/16031	A28/3C	Bolt, 2 BA	3	—	C	
28M/13324	A29/CP	Nut, 2 BA	3	—	C	
8004	10-20 TF 627	FAIRLEAD , control cables on main fin rib, rear	1	—	C	RC2
		Attachments for 10-20 TF 627, Fairlead :—				
28D/13284	A28/3C	Bolt, 2 BA	3	—	C	
28M/10328	AGS.2002/C/1	Nut, 2 BA	3	—	C	
	10-20 CF 9329A	FAIRLEAD , tube, for rudder controls, assembly, Port and Starboard	1	—	—	RC2
		Spares for :—				
11618	10-20 CF 9139	BRACKET , tube	1	—	C	RC2
		Attachments for 10-20 CF 9139, Bracket :—				
28D/9436920	A25/1C	Bolt, 2 BA	1	—	C	
28M/9403520	A27/CP	Nut, 2 BA	1	—	C	

**TAIL UNIT
FIN AND TAIL BOOM**

Ref. No.	Part No.	Description	No. off						Material Specification	Class of Score or L.M.	Plate No.
			1	2	3	4	5	6			
11619	10-20 CF 9137	TUBE , fairlead, fibreglass						1	—	C	RC2
28D/9133012	A25/3C	Attachments for 10-20 CF 9329A, Fairlead :— Bolt, 2 BA						1	—	C	
	10-20 TF 721A/2	FINHEAD , Port, assembly						1	—	—	RC2
	10-20 TF 723A/1	FINHEAD , Starboard, assembly						1	—	—	RC2
		Spares for :—									
	10-20 TF 715	ANGLE , attachment for trim unit mounting, Port, 18 SWG						1	L.72	LM	RC2
	10-20 TF 1331ND	ANGLE , L.H. (Make from standard section J278)						1	—	LM	RC9
	10-20 TF 1332ND	ANGLE , R.H. (Make from standard section J278)						1	—	LM	RC9
	10-20 TF 1191A/1	BEARING , tail plane, front, Port, assembly ... (For spares use 10-20 TF 1987A/ND)						1	—	—	RC2
15770	10-20 TF 1987A/ND	BEARING , tail plane, front, Port, assembly (Spares condition)						1	—	P	
	10-20 TF 1193A	BEARING , tail plane, front, Starboard, assembly (For spares use 10-20 TF 1989A/ND)						1	—	—	RC2
15771	10-20 TF 1989A/ND	BEARING , tail plane, front, Starboard, assembly (Spares condition)						1	—	P	
		Spares for :—									
	10-20 TF 749A	BEARING , half, bottom, Port, assembly Spares for :—						1	—	—	RC2
1635	10 TF 1065A	BEARING , connecting rod mating, assembly						1	—	C	RC2
	10-20 TF 751	FAIRLEAD , $\frac{3}{16}$ " thick Attachments for 10-20 TF 751, Fairlead :—						1	P.T.F.E.	—	RC7
28D/13356	A28/4C	Bolt, 2 BA						2	—	C	
28M/13324	A29/CP	Nut, 2 BA						2	—	C	
28W/9419402	SP.13/C	Washer						2	—	C	
28M/11957	AGS.2007/C/1	NUT , 2 BA, anchor						6	—	C	
28M/9435067	AGS.2008/C/1	NUT , 2 BA, anchor						3	—	C	
28M/12421	AGS.2018/C/1	NUT , 2 BA, anchor						1	—	C	
28M/9435560	AGS.2007/E/1	NUT , $\frac{1}{2}$ " BSF, anchor						2	—	C	
		Attachments for 10-20 TF 749A, Bearing :—									
28D/9133012	A25/3C	Bolt, 2 BA						2	—	C	
2364	DHS.901/2½E	Bolt, $\frac{1}{2}$ " BSF						33	—	C	RC2
28M/9403520	A27/CP	Nut, 2 BA						2	—	C	
2227	DHS.983/E	Nut, $\frac{1}{2}$ " BSF						33	—	C	RC2
28W/9419405	SP.15/E	Washer						6	—	C	
28W/9419404	SP.16/C	Washer						2	—	C	
	10-20 TF 1323A	BEARING , half, bottom, Starboard, assembly Spares for :—						1	—	—	RC2
1635	10 TF 1065A	BEARING , connecting rod mating, assembly						1	—	C	RC2
28M/11957	AGS.2007/C/1	NUT , 2 BA, anchor						6	—	C	
28M/9435067	AGS.2008/C/1	NUT , 2 BA, anchor						3	—	C	
28M/12421	AGS.2018/C/1	NUT , 2 BA, anchor						1	—	C	
28M/9435560	AGS.2007/E/1	NUT , $\frac{1}{2}$ " BSF, anchor						2	—	C	
		Attachments for 10-20 TF 1323A, Bearing :—									
28D/9133011	A25/2C	Bolt, 2 BA						6	—	C	
28D/9133012	A25/3C	Bolt, 2 BA						7	—	C	
2364	DHS.901/2½E	Bolt, $\frac{1}{2}$ " BSF						33	—	C	RC2
28M/9403520	A27/CP	Nut, 2 BA						13	—	C	
2227	DHS.983/E	Nut, $\frac{1}{2}$ " BSF						33	—	C	RC2
28W/9419405	SP.15/E	Washer						6	—	C	
28W/9419404	SP.16/C	Washer						2	—	C	

**TAIL UNIT
FIN AND TAIL BOOM**

Ref. No.	Part No.	Description	No. off	Material Specification	Class of Store or L.M.	Plate No.
		Attachments for 10-20 TF 1191A/1 or 10-20 TF 1193A, Bearing :-				
1660	DHS.358/4C	Bolt, 2 BA	20	—	C	RC2
28M/9403520	A27/CP	Nut, 2 BA	20	—	C	
	10-20 TF 863A	BRACKET , anchor nut, trim unit mounting, Port, assembly Spares for :-	2	—	—	RC2
	10-20 TF 865ND	BRACKET , 18 SWG	1	L.72	LM	RC2
28M/9434251	AGS.2008/B/1	NUT , 4 BA, anchor	1	—	C	
	10-20 TF 1765A	BRACKET , auto-pilot potentiometer, assembly Spares for :-	1	—	—	RC8
	10-20 TF 1767ND	BRACKET , bare, 18 SWG	1	L.72	LM	RC8
28M/9434253	AGS.2007/B/1	NUT , 4 BA, anchor	4	—	C	
	10-20 TF 1769ND	PACKING , 1"25 thick	1	LFS.21, 23 and 26	LM	RC8
		Attachments for 10-20 TF 1765A, Bracket :-				
28D/9419452	A25/3B	Bolt, 4 BA	3	—	C	
28D/8316	AS.1242/13C	Bolt, 2 BA	2	—	C	
28M/10287	AGS.2001/B/1	Nut, 4 BA	4	—	C	
28M/10288	AGS.2001/C/1	Nut, 2 BA	2	—	C	
	10-20 TF 1763ND	Tube, distance, 1/2" o/d x 3/16" i/d x 1"13 long	1	LFB.82	LM	RC8
	10-20 TF 1761ND	Tube, distance, 1/2" o/d x 3/16" i/d x 1"08 long	1	LFB.82	LM	RC8
28W/9419465	SP.13/B	Washer	6	—	C	
28W/9419402	SP.13/C	Washer	2	—	C	
	10-20 TF 1631A	BRACKET , cable guard, tailplane compensator, Starboard, assembly Spares for :-	1	—	—	RC2
	10-20 TF 1633ND	CHANNEL , 16 SWG	1	L.72	LM	RC2
28M/11957	AGS.2007/C/1	NUT , 2 BA, anchor	1	—	C	
	10-20 TF 1635	BRACKET , cable guard, tail plane compensator, Starboard only	1	L.72	LM	RC2
	10-20 TF 1120A	BRACKET , pivot, tail plane spring feel, Starboard, assembly (For spares use 10-20 TF 1836A/ND)	1	—	—	RC2
14333	10-20 TF 1836A/ND	BRACKET , pivot, tail plane spring feel, Starboard (Spares condition) Spares for :-	1	—	C	
	10-20 TF 1133	BUSH (See Repair section PA)	1	—	C	RC2
28M/9435067	AGS.2008/C/1	NUT , 2 BA, anchor	4	—	C	
16698	10-20 TF 2001A	BRACKET , pivot, tail plane spring feel unit, Starboard, assembly (Mod. 926) Spares for :-	1	—	P	RC2
	10-20 TF 1131	BUSH , screwed (See Repair section PA) ...	1	—	C	RC2
9817	10-20 TF 941A	BRACKET , skin, inner, Port and Starboard, assembly	2	—	C	RC2
	10-20 TF 1139A	BRACKET , support, gear change in Port fin, assembly (For spares use 10-20 TF 947A/ND)	1	—	—	RC2
10219	10-20 TF 947A/ND	BRACKET , support, gear change in Port fin, assembly (Spares condition) Spares for :-	1	—	P	
	10-20 TF 1683	BUSH , special, tapped 2 BA	1	—	C	RC2
28M/9435067	AGS.2008/C/1	NUT , 2 BA, anchor	3	—	C	
		Attachments for 10-20 TF 1139A, Bracket :-				
	1654	Bolt, 2 BA	9	—	C	RC2
28M/9403520	A27/CP	Nut, 2 BA	9	—	C	
28W/9419404	SP.16/C	Washer	9	—	C	

**TAIL UNIT
FIN AND TAIL BOOM**

Ref. No.	Part No.	Description	No. off	Material Specification	Class of Store or L.M.	Plate No.
	10-20 TF 923A	BRACKET , support, gear-change mounting, Port. assembly (For spares use 10-20 TF 4115A/ND)	1	—	—	RC2
17343	10-20 TF 4115A/ND	BRACKET , support, gear change mounting, Port. assembly (Spares condition) Spares for :—	1	—	C	
4453	10-20 TF 1131	BUSH , screwed	1	—	C	RC16
	10-20 TF 1685	BUSH , special	2	S.1	—	RC16
28M/9435067	AGS.2008/C/1	NUT , 2 BA, anchor	2	—	C	
17344	10-20 TF 1687	NUT , special (Mod. 1153)	2	—	C	RC16
		Attachments for 10-20 TF 923A, Bracket :—				
1654	DHS.358/2C	Bolt, 2 BA	3	—	C	RC2
1655	DHS.358/3C	Bolt, 2 BA	3	—	C	RC2
1660	DHS.358/4C	Bolt, 2 BA	3	—	C	RC2
28M/9403520	A27/CP	Nut, 2 BA	9	—	C	
28W/9419404	SP.16/C	Washer	9	—	C	
10572	10-20 TF 653	BRACKET , support, trim unit mounting, Port	1	—	C	RC2
1638	10-20 TF 475A	BRACKET , tail plane track, forward, Port, assembly	1	—	C	RC2
1639	10-20 TF 476A	BRACKET , tail plane track, forward, Starboard, assembly Spares for :—	1	—	C	RC2
3724	10-20 TF 1653	BUSH , special, 1/4" BSF	3	—	C	RC2
7153	10-20 TF 553	BUSH , special, 1/2" BSF	2	—	C	RC2
4153	DHS.94/5/65	PIN , locking, for sleeve, tail plane track	2	—	C	RC2
	10-20 TF 1655	PLATE , locking, tail plane track, 18 SWG	1	S.511	LM	RC2
	10-20 TF 1019	SLEEVE , threaded, 1/4" BSF, tail plane track	2	S.1	—	RC2
	10 TF 1015	TRACK , slider (For spares use 10-20 TF 1723ND)	2	DTD.197 or BSS.249	—	RC2
11095	10-20 TF 1723ND	TRACK , slider (Spares condition)	2	—	C	
		Attachments for 10 TF 1015, Track :—				
1655	DHS.358/3C	Bolt, 2 BA	4	—	C	RC2
28M/1006473	A27/CT	Nut, 2 BA	4	—	C	
		Attachments for 10-20 TF 475A or 10-20 TF 476A Bracket :—				
3222	DHS.901/3 1/2 E	Bolt 3/4" BSF	5	—	C	RC2
2238	DHS.901/4E	Bolt 3/4" BSF	2	—	C	RC2
2227	DHS.983/E	Nut 3/4" BSF	7	—	C	RC2
28W/9418921	SP.13/E	Washer	7	—	C	
1641	10-20 TF 477A	BRACKET , tail plane track rear Port, assembly	1	—	C	RC2
1642	10-20 TF 478A	BRACKET , tail plane track, rear, Starboard, assembly Spares for :—	1	—	C	RC2
3724	10-20 TF 1653	BUSH , special, 1/4" BSF	5	—	C	RC2
4153	DHS.94/5/65	PIN , locking, for sleeve, tail plane track...	2	—	C	RC2
	10-20 TF 1657	PLATE , locking, 18 SWG	1	S.511	LM	RC2
	10-20 TF 1659	PLATE , locking, 18 SWG	1	S.511	LM	RC2
	10 TF 1019	SLEEVE , threaded, 1/4" BSF, tailplane track	2	S.1	—	RC2
	10 TF 1017	TRACK , slider (For spares use 10-20 TF 1725ND)	2	DTD.197 or BSS.249	—	RC2
11094	10-20 TF 1725ND	TRACK , slider (Spares condition)	2	—	C	

TAIL UNIT
FIN AND TAIL BOOM

Ref. No.	Part No.	Description	No. off	Material Specification	Class of Score or L.M.	Plate No.
1655	DHS.358/3C	Attachments for 10 TF 1017, Track :—				
28M/1006473	A27/CT	Bolt, 2 BA	4	—	C	RC2
		Nut, 2 BA	4	—	C	
		Attachments for 10-20 TF 477A or 10-20 TF 478A, Bracket :—				
3777	DHS.901/4½E	Bolt, ½" BSF	4	—	C	RC2
2227	DHS.983/E	Nut, ½" BSF	4	—	C	RC2
5984	10-20 TF 513A	BRACKET , tail plane trim actuator mounting, assembly	1	—	C	RC2
		Attachments for 10-20 TF 513A, Bracket :—				
28D/9133011	A25/2C	Bolt, 2 BA	4	—	C	
28M/9403520	A27/CP	Nut, 2 BA	4	—	C	
28W/9419402	SP.13/C	Washer	4	—	C	
	10-20 TF 425A	BRIDGE , fin top rib, Port, assembly ...	1	—	—	RC3
	10-20 TF 426A	BRIDGE , fin top rib, Starboard, assembly ...	1	—	—	RC3
		Spares for :—				
28D/1011030	A25/2E	BOLT , ½" BSF, for inner and outer anchor nuts	3	—	C	
28D/1011238	A25/3E	BOLT , ½" BSF, for outer anchor nuts ...	2	—	C	
28M/9993192	AGS.2009/C/1	NUT , 2 BA, anchor	16	—	C	
28M/13481	AGS.2020/C/1	NUT , 2 BA, anchor	2	—	C	
28M/10230	AGS.2009/E/1	NUT , ½" BSF, anchor	3	—	C	
28M/9435649	AGS.2018/E/1	NUT , ½" BSF, anchor	2	—	C	
	10-20 TF 431ND	PLATE , packing, 14 SWG	1	L.72	LM	RC3
	DHS.878/E14	PLATE , packing, 14 SWG	2	L.72	LM	RC3
	10-20 TF 603ND	PLATE , packing, 16 SWG	1	L.72	—	RC3
28W/9418921	SP.13/E	WASHER	5	—	C	
		Attachments for 10-20 TF 425A or 10-20 TF 426A, Bridge :—				
28D/9133011	A25/2C	Bolt, 2 BA	2	—	C	
4926	A25/2E/DHS.514/D	Bolt, ½" BSF	14	—	C	
28M/10288	AGS.2001/C/1	Nut, 2 BA	2	—	C	
28W/9418920	SP.10/E	Washer	2	—	C	
28W/9419487	SP.16/E	Washer	4	—	C	
	DHS.781/7/16	Washer, 0"·5 o/d × 0"·265 i/d × 16 SWG ...	6	S.510	LM	RC3
	DHS.781/7/22	Washer, 0"·5 o/d × 0"·265 i/d × 22 SWG ...	2	S.510	LM	RC3
18351	10-20 TF 1469A	CAP , bearing, Port, assembly	1	—	C	RC3
18352	10-20 TF 1407A	CAP , bearing, Starboard, assembly	1	—	C	RC3
		Spares for :—				
28M/9435067	AGS.2008/C/1	NUT , 2 BA, anchor	6	—	C	
	10-20 TF 1517	PACKING , tapered, under anchor nut, L.H.	5	L.64	LM	RC3
	10-20 TF 1518	PACKING , tapered, under anchor nut, R.H.	1	L.64 or L.72	LM	RC3
		Attachments for 10-20 TF 1469A or 10-20 TF 1470A, Cap :—				
28D/1008151	A25/4E	Bolt, ½" BSF	10	—	C	
1634	10 TF 1117	Bolt, ⅜" BSF	2	—	C	RC3
28M/1011467	A27/ES	Nut, ½" BSF	10	—	C	
28M/13275	A27/PC	Nut, ⅜" BSF	2	—	C	
28P/1007741	SP.9/C8	Pin, split	10	—	C	
28P/9429653	SP.9/G12	Pin, split	2	—	C	
28W/9419492	SP.16/P	Washer	2	—	C	

**TAIL UNIT
FIN AND TAIL BOOM**

Ref. No.	Part No.	Description	No. off	Material Specification	Class of Store or L.M.	Plate No.
12401	10-20 TF 1739	CAP , blanking, for anchor nut, at elevator trim unit mounting, Port (Mod. 737)	1	—	C	RC2
	10-20 TF 1055A	CAP , detachable, access to forward tail plane bearing, Port, assembly (For spares use 10-20 TF 1819A/ND)	1	—	—	RC3
14326	10-20 TF 1819A/ND	CAP , detachable, access to forward tail plane bearing, Port, assembly (Spares condition)	1	—	P	
	10-20 TF 1056A	CAP , detachable, access to forward tail plane bearing, Starboard, assembly (For spares use 10-20 TF 1820A/ND)	1	—	—	RC3
14327	10-20 TF 1820A/ND	CAP , detachable, access to forward tail plane bearing, Starboard, assembly (Spares condition)	1	—	P	
		Attachments for 10-20 TF 1055A or 10-20 TF 1056A, Cap :—				
28D/1007975	AS.1242/1C	Bolt, 2 BA	14	—	C	
28D/8307	AS.1242/2C	Bolt, 2 BA	4	—	C	
28D/1007976	AS.1242/4C	Bolt, 2 BA	4	—	C	
28D/8310	AS.1242/6C	Bolt, 2 BA	2	—	C	
	10-20 TF 499A	CAP , detachable, rear, fin top, Port (For spares use 10-20 TF 1921A/ND)	1	—	—	RC3
14702	10-20 TF 1921A/ND	CAP , detachable, rear, fin top, Port (Spares condition)	1	—	C	
	10-20 TF 500A	CAP , detachable, rear, fin top, Starboard (For spares use 10-20 TF 1922A/ND)	1	—	—	RC3
14703	10-20 TF 1922A/ND	CAP , detachable, rear, fin top, Starboard (Spares condition)	1	—	C	
		Attachments for 10-20 TF 499A or 10-20 TF 500A, Cap :—				
28D/8307	AS.1242/2C	Bolt, 2 BA	32	—	C	
28D/8308	AS.1242/3C	Bolt, 2 BA	10	—	C	
	10-20 TF 1105	DIAPHRAGM , aft, Port, 20 SWG	1	L.72	—	RC3
	10-20 TF 463	DIAPHRAGM , aft, Starboard, 20 SWG	1	L.72	—	RC3
	10-20 TF 1089A	DIAPHRAGM , fixed, aft, detachable cap, fin top assembly (For spares use 10-20 TF 1951A/ND)	1	—	—	RC3
15091	10-20 TF 1951A/ND	DIAPHRAGM , fixed, aft, detachable cap, fin top assembly (Spares condition)	1	—	P	
14401	10-20 TF 387A	DIAPHRAGM , forward, fin top, Port, assembly	1	—	P	RC3
14402	10-20 TF 388A	DIAPHRAGM , forward, fin top, Starboard, assembly	1	—	P	RC3
		Attachments for 10-20 TF 387A or 10-20 TF 388A, Diaphragm :—				
28D/9133011	A25/2C	Bolt, 2 BA	5	—	C	
28M/9403520	A27/CP	Nut, 2 BA	5	—	C	
28W/9419404	SP.16/C	Washer	5	—	C	

**TAIL UNIT
FIN AND TAIL BOOM**

Ref. No.	Part No.	Description						No. off	Material Specification	Class of Score or L.M.	Plate No.
		1	2	3	4	5	6				
	10-20 TF 1109							1	L.72	—	RC3
	10-20 TF 461							1	L.72	—	RC3
	10-20 TF 483							1	L.72	—	RC3
	10-20 TF 1065A							1	—	—	RC3
14689	10-20 TF 1891A/ND							1	—	C	
	10-20 TF 455A							1	—	—	RC3
	10-20 TF 456A							1	—	—	RC3
28M/9434253	AGS.2007/B/1							2	—	C	
	10-20 TF 1417ND							1	L.73	—	RC4
87	S10-20 TF 1							1	—	P	RC3
	10-20 TF 1069A/1							1	—	—	RC3
8020	10-20 TF 1575							1	—	C	RC3
	10-20 TF 1611ND							1	L.72	—	RC3
	10-20 TF 1607ND							1	L.72	—	RC3
	10-20 TF 809							1	L.72	—	RC3
10428	10-20 TF 1701ND							1	—	C	
	10-20 TF 1567							1	L.72	—	RC3
10222	10-20 TF 981ND							1	—	C	
	10-20 TF 825ND							1	L.72	LM	RC3
8021	10-20 TF 1599ND							1	—	C	RC3
8022	10-20 TF 1577ND							1	—	C	RC3
28M/9993192	AGS.2009/C/1							4	—	C	
	10-20 TF 1579ND							2	L.72	LM	RC3
	10-20 TF 1598A/ND							1	—	—	RC7
10433	10-20 TF 1718A/ND							1	—	C	
	10-20 TF 1597A/ND							1	—	—	RC7
10432	10-20 TF 1717A/ND							1	—	C	
	10-20 TF 1587ND							2	L.72	LM	RC7
	10-20 TF 589A/ND							1	—	—	RC7
10430	10-20 TF 1709A/ND							1	—	C	

**TAIL UNIT
FIN AND TAIL BOOM**

Ref. No.	Part No.	Description	No. off	Material Specification	Class of Store or L.M	Plate No.
	10-20 TF 1573	RIB , lower, 20 SWG (For spares use 10-20 TF 989ND)	1	L.72	—	RC3
10249	10-20 TF 989ND	RIB , lower, 20 SWG (Spares condition)	1	—	C	
	10-20 TF 1571A	RIB , lower, sloping, assembly (For spares use 10-20 TF 983A/ND)	1	—	—	RC3
10248	10-20 TF 983A/ND	RIB , lower, sloping, assembly (Spares condition)	1	—	C	
	10-20 TF 1565A	RIB , top, horizontal, assembly (For spares use 10-20 TF 1703A/ND)	1	—	—	RC3
10429	10-20 TF 1703A/ND	RIB , top, horizontal, assembly (Spares condition)	1	—	C	
	10-20 TF 1569A	RIB , top, sloping, assembly (For spares use 10-20 TF 977A/ND)	1	—	—	RC7
10221	10-20 TF 977A/ND	RIB , top, sloping, assembly (Spares condition)	1	—	C	
	10-20 TF 1601ND	RIBLET , lower, aft, 22 SWG (For spares use 10-20 TF 1853ND)	1	L.72	—	RC3
14534	10-20 TF 1853ND	RIBLET , lower, aft (Spares condition) ...	1	—	C	
	10-20 TF 1609ND	RIBLET , lower centre, aft, 22 SWG (For spares use 10-20 TF 1851ND)	1	L.72	—	RC7
14533	10-20 TF 1851ND	RIBLET , lower centre, aft ... (Spares condition)	1	—	C	
	10-20 TF 1605ND	RIBLET , lower centre, forward, 22 SWG (For spares use 10-20 TF 1849ND)	1	L.72	—	RC7
14532	10-20 TF 1849ND	RIBLET , lower centre, forward, 22 SWG (Spares condition)	1	L.72	C	
	10-20 TF 1603ND	RIBLET , lower, forward, 22 SWG (For spares use 10-20 TF 1847ND)	1	L.72	—	RC7
14531	10-20 TF 1847ND	RIBLET , lower, forward ... (Spares condition)	1	—	C	
	10-20 TF 1585ND	SKIN , top panel, 22 SWG (For spares use 10-20 TF 1715ND)	1	L.72	—	RC7
10431	10-20 TF 1715ND	SKIN , top panel (Spares condition) ...	1	—	C	
	10-20 TF 1589ND	STIFFENER , aft, centre, Port, 22 SWG	1	L.72	LM	RC7
	10-20 TF 1590ND	STIFFENER , aft, centre, Starboard, 22 SWG	1	L.72	LM	RC7
	10-20 TF 1591ND	STIFFENER , forward, centre, Port, 22 SWG	1	L.72	LM	RC7
	10-20 TF 1592ND	STIFFENER , forward, centre, Starboard, 22 SWG	1	L.72	LM	RC7
		Attachments for 10-20 TF 1069A/1, Fairing:—				
28D/8307	AS.1242/2C	Bolt, 2 BA ...	28	—	C	
28D/9436920	A25/1C	Bolt, 2 BA ...	2	—	C	
28D/9133011	A25/2C	Bolt, 2 BA ...	2	—	C	
	10-20 TF 1011	FORMER , fin head, 20 SWG (For spares use 10-20 TF 1965ND)	1	L.72	—	RC7

**TAIL UNIT
FIN AND TAIL BOOM**

Ref. No.	Part No.	Description						No. off	Material Specification	Class of Store or L.M	Plate No.
		1	2	3	4	5	6				
15089	10-20 TF 1965ND 10-20 TF 633A										
11118	10-20 TF 999A/ND										
28M/9993192	AGS.2009/C/1 10-20 TF 1087ND 10-20 TF 639										
10427	10-20 TF 1699ND 10-20 TF 1033A										
15090	10-20 TF 1967A/ND — 10-20 TF 845A										
14661	10-20 TF 1881A/ND 10-20 TF 843A										
14660	10-20 TF 1877A/ND 10-20 TF 841A										
14659	10-20 TF 1873A/ND 10-20 TF 839A										
14697	10-20 TF 1865A/ND										
28D/9133012 28M/9403520 28W/9419475	A25/3C A27/CP SP.15/C										
	10-20 TF 837A										
14696	10-20 TF 1857A/ND										

**TAIL UNIT
FIN AND TAIL BOOM**

Ref. No.	Part No.	Description	No. off	Material Specification	Class of Store of L.M	Place No.
28M/14347	AGS.2019/E/1	NUT , 1/4" BSF, anchor ("Nyloc") ...	3	—	C	
		Attachments for 10-20 TF 837A, Bracket :—				
28D/9133011	A25/2C	Bolt, 2 BA ...	4	—	C	
28M/9403520	A27/CP	Nut, 2 BA ...	4	—	C	
28W/9419402	SP.13/C	Washer ...	4	—	C	
	10-20 TF 835A	STIFFENER , machined, aft, assembly (For spares use 10-20 TF 1869A/ND)	1	—	—	RC8
14676	10-20 TF 1869A/ND	STIFFENER , machined, aft, assembly (Spares condition)	1	—	P	
		Attachments for 10-20 TF 835A, Stiffener :—				
28D/9133011	A25/2C	Bolt, 2 BA ...	3	—	C	
28M/9403520	A27/CP	Nut, 2 BA ...	3	—	C	
28W/9419475	SP.15/C	Washer ...	3	—	C	
	10-20 TF 833A	STIFFENER , machined, forward, assembly (For spares use 10-20 TF 1861A/ND)	1	—	—	RC8
14675	10-20 TF 1861A/ND	STIFFENER , machined, forward, assembly (Spares condition)	1	—	C	
		Attachments for 10-20 TF 833A, Stiffener :—				
28D/9133011	A25/2C	Bolt, 2 BA ...	4	—	C	
28M/9403520	A27/CP	Nut, 2 BA ...	4	—	C	
28W/9419475	SP.15/C	Washer ...	4	—	C	
28M/11957	AGS.2007/C/1	NUT , 2 BA, anchor, for access cover trim unit mounting, cover panel leading edge, and skin attachment top rib	15	—	C	
28M/9435067	AGS.2008/C/1	NUT , 2 BA, anchor, for access cover and blanking cap trim unit, Port, and junction of top rib and vertical rib, Port and Starboard	6	—	C	
28M/9993192	AGS.2009/C/1	NUT , 2 BA, anchor, for access cover trim unit, and on reinforcing for access cover, mach sensitive gear change, Port	23	—	C	
28M/12421	AGS.2018/C/1	NUT , 2 BA, anchor, for access cover trim unit mounting	1	—	C	
28M/9144673	AGS.2019/C/1	NUT , 2 BA, anchor, for access cover trim unit, Port, and rear fairing at top of diaphragm	3	—	C	
28M/13481	AGS.2020/C/1	NUT , 2 BA, anchor, for access cover trim unit, Port	2	—	C	
	10-20 TF 1423ND	PACKING , under pivot bracket, 18 SWG ...	1	L.72	LM	RC8
7485	10-20 TF 647A/ND	PANEL , forward, top skin, Port, assembly	1	—	P	RC3
		Spares for :—				
	10-20 TF 645A	PANEL , forward, top skin, Port, assembly	1	—	—	RC3
		Spares for :—				
28M/9993192	AGS.2009/C/1	NUT , 2 BA, at outboard skin panel ...	4	—	C	
2258	10-20 TF 1099	PLUG , screwed, for blanking aperture at sling point	1	—	C	RC3
	7486	PANEL , forward, top skin, Starboard assembly	1	—	P	RC3
		Spares for :—				
	10-20 TF 646A	PANEL , forward top skin, Starboard assembly	1	—	—	RC3
		Spares for :—				
28M/9993192	AGS.2009/C/1	NUT , 2 BA, anchor at outboard skin panel	4	—	C	
2258	10-20 TF 1099	PLUG , screwed, for blanking aperture at sling point	1	—	C	RC3

**TAIL UNIT
FIN AND TAIL BOOM**

Ref. No.	Part No.	Description	No. off						Material Specification	Class of Score or L.M	Plate No.
			1	2	3	4	5	6			
	10-20 TF 1401ND	PANEL , upper skin, 18 SWG (For spares use 10-20 TF 1845ND)						1	L.73	—	RC7
14530	10-20 TF 1845ND	PANEL , upper skin, 18 SWG (Spares condition)						1	—	C	
20474	10-20 TF 491	PLATE , blanking, fin head rubber shroud,						1	—	C	RC3
	10-20 TF 1411ND	PLATE , gusset, Starboard, 20 SWG ...						1	L.73	LM	RC9
	10-20 TF 1287ND	PLATE , packing, for pivot bracket, 18 SWG						1	L.72	LM	RC2
	10-20 TF 1403ND	REINFORCING , edge, for panel, upper skin, 18 SWG						2	L.73	—	RC7
	10-20 TF 709A/1	RIB , fin head, Port, assembly (Mod. 52) ...						1	—	—	RC3
	10-20 TF 711A	RIB , fin head, Starboard, assembly ... Spares for 10-20 TF 709A/1 or 10-20 TF 711A, Rib :—						1	—	—	RC3
	10-20 TF 1093ND	ANGLE , L.H., 6" x 4 long (Make from standard section X21C, Ref. No. 26FY/4579)						1	—	LM	RC3
	10-20 TF 1094ND	ANGLE , R.H., 6" x 4 long (Make from standard section X21C, Ref. No. 26FT/4579)						1	—	LM	RC3
9046	10-20 TF 505	BEARING , elevator track, L.H. ...						1	—	C	RC3
9047	10-20 TF 506	BEARING , elevator track, R.H. ... Attachments for 10-20 TF 505 or 10-20 TF 506, Bearing :—						1	—	C	RC3
9797	DHS.901/2JEE	Bolt, 1/4" BSF ...						2	—	C	RC3
14464	DHS.901/4EE	Bolt, 1/4" BSF ...						4	—	C	RC3
28M/13376	A29/EP	Nut, 1/4" BSF ...						6	—	C	
	10 TF 1653A	BRACKET , for conduit clamp, assembly Spares for :—						1	—	—	RC7
	10 TF 1655ND	BRACKET , 18 SWG ...						1	L.72	LM	RC7
28M/9434252	AGS.2018/B/1	NUT , 4 BA, anchor ...						2	—	C	
28M/9434253	AGS.2007/B/1	NUT , 4 BA, anchor ...						1	—	C	
28M/9435560	AGS.2007/E/1	NUT , 1/4" BSF, anchor ...						2	—	C	
	10-20 TF 485A	RIB , fin lower, Port, assembly (For spares use 10-20 TF 4103A/ND)						1	—	—	RC7
17242	10-20 TF 4103A/ND	RIB , fin lower, Port, assembly (Spares condition)						1	—	C	
	10-20 TF 486A	RIB , fin lower, Starboard, assembly (For spares use 10-20 TF 4104A/ND)						1	—	—	RC7
17243	10-20 TF 4104A/ND	RIB , fin lower, Starboard, assembly (Spares condition)						1	—	C	
	10-20 TF 427A	RIB , fin top, aft, Port, assembly (For spares use 10-20 TF 2043A/ND)						1	—	—	RC7
21037	10-20 TF 2043A/ND	RIB , fin top, aft, Port, assembly (Spares condition)						1	—	C	
	10-20 TF 428A	RIB , fin top, aft, Starboard, assembly (For spares use 10-20 TF 2044A/ND)						1	—	—	RC7
21038	10-20 TF 2044A/ND	RIB , fin top, aft, Starboard, assembly (Spares condition) Spares for 10-20 TF 2043A/ND or 10-20 TF 2044A/ND, Rib :—						1	—	C	
28M/9435067	AGS.2008/C/1	NUT , 2 BA, anchor ...						27	—	C	
28M/9993192	AGS.2009/C/1	NUT , 2 BA, anchor ...						16	—	C	
28M/13481	AGS.2020/C/1	NUT , 2 BA, anchor ...						2	—	C	
	10-20 TF 423A	RIB , fin top, forward, assembly ...						1	—	—	RC7
	10-20 TF 1015A	RIB , forward portion, fin top, Port, assembly						1	—	—	RC7
	10-20 TF 1016A	RIB , forward portion, fin top, Starboard assembly						1	—	—	RC7

**TAIL UNIT
FIN AND TAIL BOOM**

Ref. No.	Part No.	Description	No. off	Material Specification	Class of Store or LM	Place No.
		Spares for 10-20 TF 1015A or 10-20 TF 1016A, Rib :—				
	10-20 TF 819	GUIDE , fairlead, elevator flap circuit, Port	1	LFS.23	LM	RC7
	10-20 TF 1817	GUIDE , fairlead, elevator flap circuit, Starboard (Mod. 331)	1	LFS.32	LM	RC7
		Attachments for 10-20 TF 819 or 10-20 TF 1817, Guide :—				
28D/9133011	A25/2C	Bolt, 2 BA	3	—	C	
28W/1200071	SP.23/C	Washer	3	—	C	
28M/9435067	AGS.2008/C/1	NUT , 2 BA, anchor	3	—	C	
	10-20 TF 599A/2	SKIN , inner, Port, assembly (For spares use 10-20 TF 1843A/ND)	1	—	—	RC6
14590	10-20 TF 1843A/ND	SKIN , inner, Port, assembly (Spares condition)	1	—	C	
		Spares for :—				
12401	10-20 TF 1739	CAP , blanking for anchor nut	4	—	C	RC6
28M/9435067	AGS.2008/C/1	NUT , 2 BA, anchor ("Nylor") at blanking cap	4	—	C	
28M/9993192	AGS.2009/C/1	NUT , 2 BA, anchor	57	—	C	
28M/10230	AGS.2009/E/1	NUT , 1/4" BSF, anchor	1	—	C	
		Attachments for 10-20 TF 599A/2, Skin :—				
1654	DHS.358/2C	Bolt, 2 BA	9	—	C	RC6
1655	DHS.358/3C	Bolt, 2 BA	11	—	C	RC6
2347	DHS.358/3 1/2 C	Bolt, 2 BA	30	—	C	RC6
1792	DHS.365/3C	Bolt, 2 BA	8	—	C	RC6
1653	DHS.365/2E	Bolt, 1/2" BSF	7	—	C	RC6
1657	DHS.365/3E	Bolt, 1/2" BSF	25	—	C	RC6
3234	DHS.365/4 1/2 G	Bolt, 5/16" BSF	4	—	C	RC6
26FC/11711	DHS.365/6G	Bolt, 5/16" BSF	4	—	C	RC6
28M/1006473	A27/CT	Nut, 2 BA	8	—	C	
28M/1007403	A27/ET	Nut, 1/2" BSF	25	—	C	
28M/9403520	A27/CP	Nut, 2 BA	50	—	C	
28M/5808571	A27/GS	Nut, 5/16" BSF	8	—	C	
28P/9527619	SP.90/C7	Pin, split (SP.9/C8)	3	—	C	
28W/9419402	SP.13/C	Washer	6	—	C	
28W/9419404	SP.16/C	Washer	52	—	C	
28W/9419487	SP.16/E	Washer	32	—	C	
28W/9419476	SP.15/G	Washer	8	—	C	
7883	10-20 TF 601A	SKIN , inner, Starboard, assembly	1	—	C	RC6
		Attachments for 10-20 TF 601A, Skin :—				
1654	DHS.358/2C	Bolt, 2 BA	12	—	C	RC6
1655	DHS.358/3C	Bolt, 2 BA	11	—	C	RC6
2347	DHS.358/3 1/2 C	Bolt, 2 BA	34	—	C	RC6
1792	DHS.365/3C	Bolt, 2 BA	8	—	C	RC6
1653	DHS.365/2E	Bolt, 1/2" BSF	7	—	C	RC6
1657	DHS.365/3E	Bolt, 1/2" BSF	25	—	C	RC6
3234	DHS.365/4 1/2 G	Bolt, 5/16" BSF	4	—	C	RC6
26FC/11711	DHS.365/6G	Bolt, 5/16" BSF	4	—	C	RC6
28M/1006473	A27/CT	Nut, 2 BA	8	—	C	
28M/1007403	A27/ET	Nut, 1/2" BSF	32	—	C	
28M/9403520	A27/CP	Nut, 2 BA	54	—	C	
28M/5808571	A27/GS	Nut, 5/16" BSF	8	—	C	
28P/9527619	SP.90/C7	Pin, split (SP.9/C8)	8	—	C	
28W/9419402	SP.13/C	Washer	6	—	C	
28W/9419475	SP.15/C	Washer	11	—	C	
28W/9419404	SP.16/C	Washer	40	—	C	
28W/9419487	SP.16/E	Washer	32	—	C	
28W/9419476	SP.15/G	Washer	8	—	C	

TAIL UNIT
FIN AND TAIL BOOM

Ref. No.	Part No.	Description	No. off	Material Specification	Class of Store or L.M	Plate No.
	10-20 TF 1917A	SKIN , outer, Port, assembly (Mod. 737) (For spares use 10-20 TF 1981A/ND)	1	—	—	RC6
15452	10-20 TF 1981A/ND	SKIN , outer, Port, assembly (Spares condition) Spares for:—	1	—	C	
12401	10-20 TF 1739	CAP , blanking, anchor nut	3	—	C	RC6
28M/9435067	AGS.2008/C/1	NUT , 2 BA, anchor ("Nylloc")	3	—	C	
28M/11957	AGS.2007/C/1	NUT , 2 BA, anchor	1	—	C	
28M/9993192	AGS.2009/C/1	NUT , 2 BA, anchor	90	—	C	
		Attachments for 10-20 TF 1917A, Skin:—				
1654	DHS.358/2C	Bolt, 2 BA	12	—	C	RC6
1655	DHS.358/3C	Bolt, 2 BA	15	—	C	RC6
2347	DHS.358/3½C	Bolt, 2 BA	30	—	C	RC6
4371	DHS.365/2½C	Bolt, 2 BA	8	—	C	RC6
1792	DHS.365/3C	Bolt, 2 BA	8	—	C	RC6
1657	DHS.365/3E	Bolt, ¾" BSF	25	—	C	RC6
28M/1006473	A27/CT	Nut, 2 BA	8	—	C	
28M/1007403	A27/ET	Nut, ¾" BSF	23	—	C	
28M/9403520	A27/CP	Nut, 2 BA	46	—	C	
28M/10288	AGS.2001/C/1	Nut, 2 BA	16	—	C	
28M/10290	AGS.2001/E/1	Nut, ¾" BSF	12	—	C	
28W/9419402	SP.13/C	Washer	10	—	C	
28W/9419404	SP.16/C	Washer	60	—	C	
28W/9419487	SP.16/E	Washer	31	—	C	
	—	SKIN , outer, Starboard, group (Pre Mod. 64)	1	—	—	
	10-20 TF 1151A	DOUBLER , machined	1	—	—	RC6
		Spares for:—				
28M/9993192	AGS.2009/C/1	NUT , 2 BA, anchor	83	—	C	
	10-20 TF 1433ND	SKIN , outer, 18 SWG	1	DTD.746	—	RC6
	10-20 TF 607A	SKIN , outer, Starboard, assembly (Mod. 64) (For spares use 10-20 TF 1855A/ND)	1	—	—	RC6
14535	10-20 TF 1855A/ND	SKIN , outer, Starboard, assembly (Spares condition)	1	—	—	
		Attachments for 10-20 TF 607A, Skin:—				
1654	DHS.358/2C	Bolt, 2 BA	12	—	C	RC6
1655	DHS.358/3C	Bolt, 2 BA	12	—	C	RC6
2347	DHS.358/3½C	Bolt, 2 BA	39	—	C	RC6
4371	DHS.365/2½C	Bolt, 2 BA	8	—	C	RC6
1653	DHS.365/2E	Bolt, ¾" BSF	6	—	C	RC6
1657	DHS.365/3E	Bolt, ¾" BSF	26	—	C	RC6
28M/1006473	A27/CT	Nut, 2 BA	16	—	C	
28M/1007403	A27/ET	Nut, ¾" BSF	20	—	C	
28M/9403520	A27/CP	Nut, 2 BA	46	—	C	
28M/10290	AGS.2001/E/1	Nut, ¾" BSF	12	—	C	
28W/9419402	SP.13/C	Washer	4	—	C	
28W/9419404	SP.16/C	Washer	66	—	C	
28W/9419487	SP.16/E	Washer	20	—	C	
	10-20 TF 1021A	SPAR , false, fin top, Port, assembly	1	—	—	RC3
	10-20 TF 1022A	SPAR , false, fin top, Starboard, assembly	1	—	—	RC3
		Spares for:—				
	10 TF 1650	BRACKET , conduit clip (Starboard only), 18 SWG	1	L.72	LM	RC3

TAIL UNIT FIN AND TAIL BOOM

Ref. No.	Part No.	Description	No of	Material Specification	Iss of Store or L.M.	Place No
28M/9434251	AGS.2008/B/1	NUT , 4 BA, anchor	1	—	C	
28M/12153	AGS.2007/B/1	NUT , 4 BA, anchor	4	—	C	
	10-20 TF 1789	PLATE , packing, Port, 14 SWG	1	L.72	—	RC3
17150	10-20 TF 493A	SPAR , fin top, Port, assembly	1	—	C	RC7
17147	10-20 TF 494A	SPAR , fin top, Starboard, assembly	1	—	C	RC7
		Spares for :—				
	10 TF 1561	FAIRLEAD , for conduit	1	LFS.23-26	LM	RC7
	10-20 TF 497ND	REINFORCING , 18 SWG	1	L.73	LM	RC7
	10-20 TF 1101ND	SPAR , fin top, Port, 16 SWG	1	L.73	LM	RC7
	10-20 TF 1102ND	SPAR , fin top, Starboard, 16 SWG	1	L.73	LM	RC7
10573	10-20 TF 701	SPIGOT , trim unit mounting, Port	1	—	C	RC7
		Attachments for 10-20 TF 701, Spigot :—				
28D/8308	AS.1242/3C	Bolt, 2 BA	3	—	C	
28M/1006473	A27/CT	Nut, 2 BA	3	—	C	
28W/9419402	SP.13/C	Washer	3	—	C	
	10-20 TF 1301ND	STIFFENER , L.H. (Make from Standard section × 21 C, Ref. No. 26FY/4579)	1	—	LM	RC9
	10-20 TF 1303ND	STIFFENER , L.H. (Make from Standard section × 21 C, Ref. No. 26FY/4579)	1	—	LM	RC9
	10-20 TF 1425ND	STIFFENER , L.H. (Make from Standard section × 21 C, Ref. No. 26FY/4579)	1	—	LM	RC9
	10-20 TF 1427ND	STIFFENER , L.H. (Make from Standard section × 21 C, Ref. No. 26FY/4579)	1	—	LM	RC9
	10-20 TF 1429ND	STIFFENER , L.H. (Make from Standard section × 21 C, Ref. No. 26FY/4579)	1	—	LM	RC9
	10-20 TF 1437ND	STIFFENER , L.H. (Make from Standard section × 21 C, Ref. No. 26FY/4579)	1	—	LM	RC9
	10-20 TF 1405ND	STIFFENER , L.H. (Make from Standard section × 21 B, Ref. No. 26FY/2565)	1	—	LM	RC9
	10-20 TF 1415ND	STIFFENER , (Make from Standard section J.800, Ref. No. 26FY/4580)	1	—	LM	RC9
	10-20 TF 1413ND	STIFFENER , (Make from Standard section J.800, Ref. No. 26FY/4580)	1	—	LM	RC9
	10-20 TF 1281ND	STIFFENER , (Make from Standard section × 21 C, Ref. No. 26FY/4579)	1	—	LM	RC9
	10-20 TF 1283ND	STIFFENER , (Make from Standard section × 21 C, Ref. No. 26FY/4579)	1	—	LM	RC9
	10-20 TF 1285ND	STIFFENER , (Make from Standard section × 21 C, Ref. No. 26FY/4579)	1	—	LM	RC9
	10-20 TF 1329ND	STIFFENER , Port fairing (Make from Standard Section J.645, aged to L.73)	2	—	LM	RC9
	10-20 TF 1779	STIFFENER , Port only, 18 SWG	1	L.73	LM	RC9
	10-20 TF 1315	STIFFENER , Port only, 18 SWG	1	L.72	LM	RC9
	10-20 TF 1296ND	STIFFENER , R.H. (Make from Standard section × 21 C, Ref. No. 26FY/4579)	1	—	LM	RC9
	10-20 TF 1302ND	STIFFENER , R.H. (Make from Standard section × 21 C, Ref. No. 26FY/4579)	1	—	LM	RC9
	10-20 TF 1309ND	STIFFENER , R.H. (Make from Standard section × 21 C, Ref. No. 26FY/4579)	1	—	LM	RC9
	10-20 TF 1304ND	STIFFENER , R.H. (Make from Standard section × 21 C, Ref. No. 26FY/4579)	1	—	LM	RC9
	10-20 TF 1398ND	STIFFENER , R.H. (Make from Standard section J.800, Ref. No. 26FY/4580)	1	—	LM	RC9
	10-20 TF 1438ND	STIFFENER , R.H. (Make from Standard section J.800, Ref. No. 26FY/4580)	1	—	LM	RC9

TAIL UNIT
FIN AND TAIL BOOM

Ref. No.	Part No.	Description						No. off	Material Specification	Class of Store or L.M.	Plate No.
		1	2	3	4	5	6				
	10-20 TF 1436ND							1	—	LM	RC9
	10-20 TF 1426ND							1	—	LM	RC9
	10-20 TF 1428ND							1	—	LM	RC9
	10-20 TF 1430ND							1	—	LM	RC9
	10-20 TF 1330ND							2	—	LM	RC9
	10-20 TF 1780							1	L.73	LM	RC9
	10-20 TF 703							1	L.72	LM	RC9
	10-20 TF 1298ND							1	—	LM	RC8 RC9
26DL/7804	DHS.437/C							1	—	C	RC9
2339	DHS.358/5C							2	—	C	RC9
28W/9419475	SP.15/C							2	—	C	
1644	10-20 TF 1027							1	—	C	RC7
3222	DHS.901/3½E							4	—	C	RC7
2227	DHS.983/E							4	—	C	RC7
28M/10230	AGS.2009/E/1							6	—	C	
28M/10230	AGS.2009/E/1							5	—	C	
28M/9435067	AGS.2008/C/1							6	—	C	
28M/9993192	AGS.2009/C/1							40	—	C	
28M/9144673	AGS.2019/C/1							10	—	C	
28M/9435068	AGS.2008/E/1							3	—	C	
28M/10230	AGS.2009/E/1							7	—	C	
28M/11957	AGS.2007/C/1							1	—	C	
	10-20 TF 1979ND							1	L.16	LM	RC9
	10-20 TF 1980ND							1	L.16	LM	RC9
	10-20 TF 4139ND							QR	L.72	—	RC9
	10-20 TF 1557ND							1	L.72	LM	RC9

**TAIL UNIT
FIN AND TAIL BOOM**

Ref. No.	Part No.	Description	No. off						Material Specification	Class of Score or L.M.	Plate No.
			1	2	3	4	5	6			
	10-20 TF 1559ND	PACKING , reinforcement, inner skin, at corners, between fin stringers "C" and "D," L.H., 18 SWG	1						L.72	LM	RC9
	10-20 TF 1554ND	PACKING , reinforcement, inner skin, at corners, between fin stringers "C" and "D," R.H., 18 SWG	1						L.72	LM	RC9
	10-20 TF 1558ND	PACKING , reinforcing, inner skin, at corners, between fin stringers "C" and "D," R.H., 18 SWG	1						L.72	LM	RC9
	10-20 TF 1560ND	PACKING , reinforcement, inner skin, at corners, between fin stringers "C" and "D," R.H., 18 SWG	1						L.72	LM	RC9
	10-20 TF 1553ND	PACKING , reinforcement, outer skin, between fin stringer "C" and "D," 18 SWG	1						L.72	LM	RC9
1603	10-20 TF 1465	PLATE , joint, L.H., fin head to fin, assembly ...	1						—	C	RC5
1604	10-20 TF 1466	PLATE , joint, R.H., fin head to fin, assembly ... Attachments for 10-20 TF 1465 or 10-20 TF 1466, Plate :—	1						—	C	RC5
1792	DHS.365/3C	Bolt, 2 BA	12						—	C	RC5
28M/9403520	A27/CP	Nut, 2 BA	12						—	C	
28W/9419475	SP.15/C	Washer	12						—	C	
1647	10 TF 1751A	PLATE , cover, inner skin access hole at centre rudder hinge bracket, assembly	2						—	C	RC6
	10-20 TF 959ND	LIP , attachment, 18 SWG	1						L.72	—	RC6
	10-20 TF 957ND	PLATE , bare, 18 SWG	1						L.72	—	RC6
		Attachment for 10 TF 1751A, Plate :—									
7193	DHS.964/2C	Bolt, 2 BA	1						—	C	RC6
	10-20 TF 1388A	PLATE , doubling, outboard, Port fin, assembly	1						—	—	RC6
	10-20 TF 1387A	PLATE , doubling, outboard, Starboard fin, assembly Spares for :—	1						—	—	RC6
28M/9993192	AGS.2009/C/1	NUT , 2 BA, anchor	14						—	C	
	10-20 TF 1471ND	PLATE , joint at intersection of fin rib No. 10 and forward diaphragm, 14 SWG	1						L.73	—	RC5
	10-20 TF 1472ND	PLATE , joint, at intersection of fin rib No. 10 and forward diaphragm, 14 SWG	1						L.73	—	RC5
	10-20 TF 1475ND	PLATE , joint, butt strap, Port, 16 SWG ...	1						L.73	—	RC5
	10-20 TF 1476ND	PLATE , joint, butt strap, Starboard, 16 SWG ...	1						L.73	—	RC5
	10-20 TF 1551ND	PLATE , packing, at fin joint to boom, forward of fin stringer "A," 18 SWG Attachments for 10-20 TF 1551ND, Plate :—	1						L.72	—	RC9
1092	DHS.365/2C	Bolt, 2 BA	24						—	C	RC9
2729	DHS.365/3½C	Bolt, 2 BA	4						—	C	RC9
28M/10288	AGS.2001/C/1	Nut, 2 BA	28						—	C	
28W/9419475	SP.15/C	Washer	28						—	C	
	10-20 TF 571A	PLATE , reinforcing, inboard, Port, at rudder mass balance access hole, assembly	1						—	—	RC6
	10-20 TF 572A	PLATE , reinforcing, inboard, Starboard, at rudder mass balance access hole, assembly Spares for :—	1						—	—	RC6
	10-20 N 9755A	BRACKET , assembly Spares for :—	2						—	—	RC6
28M/13774	AGS.2019/B/1	NUT , 4 BA, anchor	2						—	C	
28M/9435067	AGS.2008/C/1	NUT , 2 BA, anchor, Port	4						—	C	
28M/9993192	AGS.2009/C/1	NUT , 2 BA, anchor, Port	16						—	C	
28M/9993192	AGS.2009/C/1	NUT , 2 BA, anchor, Starboard	20						—	C	

**TAIL UNIT
FIN AND TAIL BOOM**

Ref. No.	Part No.	Description	No. off	Material Specification	Class of Store or L.M.	Place No.	
							1
	10-20 TF 1541A	PLATE , reinforcing, skin, outer, at fin joint to boom, Port	1	—	—	RC6	
	10-20 TF 1542A	PLATE , reinforcing, skin, outer, at fin joint to boom, Starboard	1	—	—	RC6	
28M/9993192	AGS.2009/C1	Spares for :—	10	—	C		
	10-20 TF 1545ND	PLATE , 2 BA, anchor	1	L.72	—	RC6	
	10-20 TF 1546ND	PLATE , packing, L.H., 18 SWG	1	L.72	—	RC6	
	10-20 TF 567A	PLATE , reinforcing, outboard, Port, at rudder mass balance access hole, assembly	1	—	—	RC6	
	10-20 TF 568A	PLATE , reinforcing, outboard, Starboard, at rudder mass balance access hole, assembly	1	—	—	RC6	
28M/9993192	AGS.2009/C/1	Spares for :—	16	—	C		
	10-20 TF 1563	NUT , 2 BA, anchor	1	DTD.746	—	RC6	
	10-20 TF 1564	PLATE , reinforcing, outer skin at head of false spar, Port, 16 SWG	1	DTD.746	—	RC6	
	10-20 TF 1509ND	PLATE , reinforcing, outer skin at head of false spar, Starboard, 16 SWG	1	L.72	—	RC9	
	10-20 TF 1510ND	REINFORCING , fin joint to boom, inner skin, Port, 16 SWG	1	L.72	—	RC9	
	10-20 TF 687A	REINFORCING , fin joint to boom, inner skin, Starboard, 16 SWG	1	—	—	RC6	
	10-20 TF 688A	REINFORCING , for cover plate, inboard, between fin ribs Nos. 8 and 9, Port, assembly	1	—	—	RC6	
28M/9993192	AGS.2009/C/1	REINFORCING , for cover plate, inboard, between fin ribs Nos. 8 and 9, Starboard, assembly	1	—	—	RC6	
	10-20 TF 689ND	NUT , 2 BA, anchor	14	—	C		
	10-20 TF 690ND	PLATE , bare, L.H., 16 SWG	1	L.73	LM	RC6	
	10-20 TF 1825ND	PLATE , bare, R.H., 16 SWG	1	L.73	LM	RC6	
	10-20 TF 1826ND	PLATE , packing, L.H., 18 SWG	1	L.72	LM	RC6	
	10-20 TF 1827ND	PLATE , packing, R.H., 18 SWG	1	L.72	LM	RC6	
	10-20 TF 1828ND	PLATE , packing, L.H., 18 SWG	1	L.72	LM	RC6	
	10-20 TF 1828ND	PLATE , packing, R.H., 18 SWG	1	L.72	LM	RC6	
	10-20 TF 1195A	RIB , fin, No. 8, Port, assembly	1	—	—	RC3	
	10-20 TF 1196A	RIB , fin, No. 8, Starboard, assembly	1	—	—	RC3	
		Spares for :—					
	18413	10-20 TF 4131ND	ANGLE , reinforcing inboard aft, Port... .. (Mod. 1246)	1	—	C	RC3
	18418	10-20 TF 4132ND	ANGLE , reinforcing inboard aft, Starboard (Mod. 1246)	1	—	C	RC3
18414	10-20 TF 4133ND	ANGLE , reinforcing inboard forward, Port (Mod. 1246)	1	—	C	RC3	
18415	10-20 TF 4134ND	ANGLE , reinforcing inboard forward, Starboard (Mod. 1246)	1	—	C	RC3	
18416	10-20 TF 4135ND	ANGLE , reinforcing outboard, Port (Mod. 1246)	1	—	C	RC3	
18417	10-20 TF 4136ND	ANGLE , reinforcing outboard, Starboard (Mod. 1246)	1	—	C	RC3	
28M/13307	10-20 TB 883A	BRACKET , mounting for clamp block, assembly	1	—	—	RC3	
	10-20 TB 881ND	BRACKET , bare, 18 SWG	1	L.72	LM	RC3	
	AGS.2018/B/1	NUT , 4 BA, anchor	2	—	C		
	10-20 S 8069A	CLAMP , L.H. for hydraulic pipes, Port and Starboard, assembly	1	—	—	RC3	
	Spares for :—						
7059	10-20 S 8071ND	CLAMP , block, L.H., ½" thick	1	LFS.21 or 23	C	RC3	

TAIL UNIT
FIN AND TAIL BOOM

Ref. No.	Part No.	Description	No. off	Material Specification	Class of Score or L/M	Plate No.
7060	10-20 S 8073ND	CLAMP , body, L.H., $\frac{1}{2}$ " thick	1	LFS.21 or 23	C	RC3
		Attachments for 10-20 S 8071ND to 10-20 S 8073ND, Clamp :—				
28D/9140644	A25/9C	Bolt, 2 BA	2	—	C	
28W/9419475	SP.15/C	Washer	2	—	C	
28M/9435067	AGS.2008/C/1	NUT , 2 BA, anchor	2	—	C	
28D/12533	A25/5C	Attachments for 10-20 S 8069A, Clamp :—				
		Bolt, 2 BA	2	—	C	
	10-20 S 8070A	CLAMP , R.H., for hydraulic pipes, Port and Starboard, assembly	1	—	—	RC3
		Spares for :—				
7061	10-20 S 8072ND	CLAMP , block, R.H., $\frac{1}{2}$ " thick	1	LFS.21 or 23	C	RC3
7062	10-20 S 8074ND	CLAMP , body, R.H., $\frac{1}{2}$ " thick	1	LFS.21 or 23	C	RC3
28M/9435067	AGS.2008/C/1	NUT , 2 BA, anchor	2	—	C	
		Attachments for 10-20 S 8072ND to 10-20 S 8074ND, Clamp :—				
28D/9140644	A25/9C	Bolt, 2 BA	2	—	C	
28W/9419475	SP.15/C	Washer	2	—	C	
28D/12533	A25/5C	Attachments for 10-20 S 8070A, Clamp :—				
		Bolt, 2 BA	2	—	C	
	10-20 TF 537	FAIRLEAD , flying control cables, Port and Starboard, $\frac{1}{2}$ " thick	1	LFS.23 or 26	LM	RC3
		Attachments for 10-20 TF 537, Fairlead :—				
28D/9419452	A25/3B	Bolt, 4 BA	2	—	C	
28W/9419401	SP.10/B	Washer	2	—	C	
	10-20 TF 539	FAIRLEAD , flying control cables, Port only, $\frac{1}{4}$ " thick	1	P.T.F.E.	—	RC3
		Attachments for 10-20 TF 539, Fairlead :—				
28D/9419452	A25/3B	Bolt, 4 BA	2	—	C	
28W/9419401	SP.10/B	Washer	2	—	C	
	10 TF 65	FAIRLEAD , rudder control cables, Port and Starboard	1	LFS.26	LM	RC3
28M/8904	AGS.2012/B/11	NUT , 4 BA, anchor, for clamp bracket ...	2	—	C	
28M/12153	AGS.2007/B/1	NUT , 4 BA, anchor, for flying control cable fairleads	3	—	C	
28M/13307	AGS.2018/B/1	NUT , 4 BA, anchor, for flying control cable fairleads, Port	1	—	C	
28M/11957	AGS.2007/C/1	NUT , 2 BA, anchor, for pipe clamp, L.H. and R.H.	2	—	C	
	10-20 TF 1199A	RIB , fin, No. 9, Port, assembly	1	—	—	RC3
	10-20 TF 1200A	RIB , fin, No. 9, Starboard, assembly ...	1	—	—	RC3
		Spares for :—				
18407	10-20 TF 4127ND	ANGLE , reinforcing inboard, Port (Mod. 1246)	1	—	C	RC3
18408	10-20 TF 4128ND	ANGLE , reinforcing inboard, Starboard ... (Mod. 1246)	1	—	C	RC3
18409	10-20 TF 4129ND	ANGLE , reinforcing outboard, Port ... (Mod. 1246)	1	—	C	RC3
18410	10-20 TF 4130ND	ANGLE , reinforcing outboard, Starboard ... (Mod. 1246)	1	—	C	RC3
	10-20 S 8063A	BRACKET , angle, attachment for hydraulic clamps, assembly	1	—	—	RC3
	10-20 S 8065ND	BRACKET , bare, 18 SWG	1	L.72	LM	RC3

**TAIL UNIT
FIN AND TAIL BOOM**

Ref. No.	Part No.	Description	No. off	Material Specification	Class of Store or LM	Plate No.
28M/9144673	AGS.2019/C/1	NUT , 2 BA, anchor	2	—	C	
7063	10-20 S 8067	CLAMP , half, bottom, for hydraulic pipes ...	1	Helathene Grade A	C	RC3
7064	10-20 S 8068	CLAMP , half, top, for hydraulic pipes ...	1	Helathene Grade A	C	RC3
		Attachments for 10-20 S 8067 to 10-20 S 8068, Clamp :—				
28D/9435710	A25/11C	Bolt , 2 BA	2	—	C	
7189	DHS.738/3/65	Strip , capping	1	L.72	C	RC3
	10 TF 1563	FAIRLEAD , flying control cables, Port and Starboard	2	LFS.26	LM	RC3
	10-20 TF 707A	RIB , fin, No. 10, Port, assembly	1	—	—	RC7
	10-20 TF 708A	RIB , fin, No. 10, Starboard, assembly	1	—	—	RC7
		Spares for :—				
18411	10-20 TF 4137ND	ANGLE , reinforcing, Starboard (Mod. 1246) ...	1	—	C	RC7
18412	10-20 TF 4138ND	ANGLE , reinforcing, Port (Mod. 1246) ...	1	—	C	RC7
	10-20 CF 1715A	BRACKET , bearing, rudder booster controls, Port, assembly (For spares use 10-20 CF 9735A/ND)	1	—	—	RC7
14294	10-20 CF 9735A/ND	BRACKET , bearing, rudder booster controls, Port, assembly (Spares condition)	1	—	C	
	10-20 CF 1716A	BRACKET , bearing, rudder booster controls, Starboard, assembly (For spares use 10-20 CF 9736A/ND)	1	—	—	RC7
14295	10-20 CF 9736A/ND	BRACKET , bearing, rudder booster controls, Starboard, assembly (Spares condition)	1	—	C	
		Spares for :—				
3718	10-20 CF 5055	BUSH , tapped, $\frac{5}{16}$ " BSF	1	S.1	C	RC7
9054	10-20 CF 1711A	BRACKET , bearing, rudder torque shaft, bottom, Port, assembly	1	—	P	RC7
9055	10-20 CF 1712A	BRACKET , bearing, rudder torque shaft, bottom, Starboard, assembly	1	—	P	RC7
		Spares for :—				
	HOFFMANN UL.55	BEARING , ball	1	—	—	
1620	10-20 CF 2417	RING , retaining bearing	1	—	C	RC7
		Attachments for 10-20 CF 1711A or 10-20 CF 1712A, Bracket :—				
28D/9133012	A25/3C	Bolt , 2 BA	3	—	C	
28D/8308	AS.1242/3C	Bolt , 2 BA	1	—	C	
28D/15710	A59/5E	Bolt , $\frac{1}{2}$ " BSF	2	—	C	
28M/9403520	A27/CP	Nut , 2 BA	4	—	C	
28M/12928	A27/EP	Nut , $\frac{1}{2}$ " BSF	2	—	C	
	10-20 TF 265	Plate , washer (forward pair of bolts) 12 SWG	2	L.72	LM	RC7
	10-20 TF 267	Plate , washer (rear pair of bolts) 12 SWG ...	2	L.72	LM	RC7
28W/9419402	SP.13/C	Washer	4	—	C	
	10-20 TF 257A	BRACKET , clamp, Port, assembly	1	—	—	RC7
	10-20 TF 258A	BRACKET , clamp, Starboard, assembly	1	—	—	RC7
		Spares for :—				
28M/13307	AGS.2019/B/1	NUT , 4 BA, anchor	2	—	C	
1617	10-20 TF 261	BRACKET , reinforcing	1	L.53	C	RC7
	10-20 TF 251	CHANNEL , reinforcing, Port, aft	1	L.72	—	RC7
	10-20 TF 252	CHANNEL , reinforcing, Starboard, aft	1	L.72	—	RC7
	10-20 TF 253	CHANNEL , reinforcing, Port, forward	1	L.72	—	RC7
	10-20 TF 254	CHANNEL , reinforcing, Starboard, forward	1	L.72	—	RC7

**TAIL UNIT
FIN AND TAIL BOOM**

Ref. No.	Part No.	Description	No. off						Material Specification	Class of Store or L.M	Place No.
			1	2	3	4	5	6			
9776	10-20 TF 883 10-20 TF 1781ND	FAIRLEAD , detachable FAIRLEAD , detachable, 0".25 thick Attachments for 10-20 TF 883 or 10-20 TF 1781ND, Fairlead :—						1	—	C	RC7
28D/9434862	A61/6C	Bolt, 2 BA						2	—	C	
9775	10-20 TF 881 10-20 TF 523	FAIRLEAD , fixed... .. FAIRLEAD , Port, 1" thick Attachments for 10-20 TF 523, Fairlead :—						1	—	C	RC7
28D/9140638	A25/4B	Bolt, 4 BA						4	—	C	
28W/9419465	SP.13/B	Washer						4	—	C	
	10-20 TF 529 10-20 TF 1223	FAIRLEAD , Port, 1" thick FAIRLEAD , Starboard, 1" thick Attachments for 10-20 TF 529 or 10-20 TF 1223, Fairlead :—						1	P.T.F.E.	—	RC7
								1	LFS.26	—	RC7
28D/9419452	A25/3B	Bolt, 4 BA						4	—	C	
28D/9140638	A25/4B	Bolt, 4 BA						1	—	C	
28W/9419465	SP.13/B	Washer						5	—	C	
28M/11957	AGS.2007/C/1	NUT , 2 BA, anchor						2	—	C	
28M/9435560	AGS.2007/E/1	NUT , 1" BSF, anchor, Port						2	—	C	
28M/9434252	AGS.2018/B/1	NUT , 4 BA, anchor, Starboard						1	—	C	
	10-20 TF 1935A 10-20 TF 706A/1	RIB , fin, No. 11, Port, assembly (Mod. 650) RIB , fin, No. 11, Starboard, assembly						1	—	—	RC7
		Spares for :—						1	—	—	RC7
	10-20 CF 3309A	BEAM , stop, rudder control in fin, Port, assembly (For spares use 10-20 CF 8813A/ND)						1	—	—	RC7
1599	10-20 CF 8813A/ND	BEAM , stop, rudder control in fin, Port, assembly (Spares condition)						1	—	C	
	10-20 CF 3310A	BEAM , stop, rudder control in fin, Starboard, assembly (For spares use 10-20 CF 8814A/ND)						1	—	—	RC7
1600	10-20 CF 8814A/ND	BEAM , stop, rudder control in fin, Starboard, assembly (Spares condition)						1	—	C	
	10-20 TF 519A	BRACKET , angle, mounting for clamp block, Port, assembly						1	—	—	RC7
	10-20 TF 520A	BRACKET , angle, mounting for clamp block, Starboard, assembly Spares for :—						1	—	—	RC7
	10-20 TF 517ND	BRACKET , bare, Port, 18 SWG						1	L.72	LM	RC7
	10-20 TF 518ND	BRACKET , bare, Starboard, 18 SWG						1	L.72	LM	RC7
28M/9434253	AGS.2007/B/1	NUT , 4 BA, anchor						2	—	C	
	10-20 CF 1641A	BRACKET , cable guide, Port, assembly (For spares use 10-20 CF 8683A/ND)						1	—	—	RC7
11914	10-20 CF 8683A/ND	BRACKET , cable guide, Port, assembly (Spares condition)						1	—	C	
	10-20 CF 1642A	BRACKET , cable guide, Starboard, assembly (For spares use 10-20 CF 8684A/ND)						1	—	—	RC7
11915	10-20 CF 8684A/ND	BRACKET , cable guide, Starboard, assembly (Spares condition)						1	—	C	
		Spares for :—									
3718	10-20 CF 5055	BUSH , tapped, 1/8" BSF						1	—	C	RC7

**TAIL UNIT
FIN AND TAIL BOOM**

Ref. No.	Part No.	Description	No. off	Material Specification	Class of Store or L.M.	Plate No.
11620	10-20 TF 1737A 10-20 TF 993	FAIRLEAD , for elevator cables, Port, assembly FAIRLEAD , for elevator cables, Starboard	1 1	— LFS.23 or 26	C LM	RC7 RC7
		Attachments for 10-20 TF 1737A or 10-20 TF 993, Fairlead :—				
28D/9140638 28W/9419465	A25/4B SP.13/B	Bolt, 4 BA Washer	4 4	— —	C C	
	10-20 TF 531 10-20 TF 213	FAIRLEAD , for hydraulic pipes, Port, 1/4" thick FAIRLEAD , for hydraulic pipes, Starboard, 1/4" thick	1 1	P.T.F.E. LFS.23	LM LM	RC7 RC7
		Attachments for 10-20 TF 531 or 10-20 TF 213, Fairlead :—				
28D/9140638 28W/9419465	A25/4B SP.13/B	Bolt, 4 BA Washer	2 2	— —	C C	
28M/9434253 28M/9434252	AGS.2007/B/1 AGS.2018/B/1 10-20 TF 541A	NUT , 4 BA, anchor, for elevator cable fairleads NUT , 4 BA, anchor, for hydraulic pipe fairlead RIB , nose, fin, Port, assembly (For spares use 10-20 TF 1973A/ND)	4 1 1	— — —	C C —	RCS
15242	10-20 TF 1973A/ND 10-20 TF 542A	RIB , nose, fin, Port, assembly (Spares condition) RIB , nose, fin, Starboard, assembly (For spares use 10-20 TF 1974A/ND)	1 1	— —	C —	C RCS
15243	10-20 TF 1974A/ND	RIB , nose fin, Starboard, assembly (Spares condition) Spares for :—	1	—	C	
	10-20 TF 545ND 10-20 TF 546ND 10-20 TF 795	ANGLE , stiffening, Port, 20 SWG ANGLE , stiffening, Starboard, 20 SWG BRACKET , attachment for fairlead tube, Port, 20 SWG	1 1 1	L.72 L.72 L.72	LM LM LM	RCS RCS RCS
	10-20 TF 796	BRACKET , attachment for fairlead tube, Star- board, 20 SWG	1	L.72	LM	RCS
	10-20 TF 817	BRACKET , attachment for fairlead tube, Star- board, 20 SWG	1	L.72	LM	RCS
	10-20 TF 818	BRACKET , attachment for fairlead tube, Star- board, 18 SWG	1	L.72	LM	RCS
28M/9435067 28M/9144673	AGS.2008/C/1 AGS.2019/C/1	NUT , 2 BA, anchor NUT , 2 BA, anchor	2 2	— —	C C	
		Attachments for 10-20 TF 541A or 10-20 TF 542A, Rib :—				
28D/9436920	A25/1C	Bolt, 2 BA	3	—	C	
	10-20 TF 1339A/ND	SKIN , front side, inboard, c/w stringers, Port assembly (For spares use 10-20 TF 1837A/ND)	1	—	—	RC9
14605	10-20 TF 1837A/ND 10-20 TF 1340A/ND	SKIN , front side, inboard, c/w stringers, Port, assembly (Spares condition) SKIN , front side, inboard, c/w stringers, Starboard, assembly (For spares use 10-20 TF 1838A/ND)	1 1	— —	C —	C RC9
14606	10-20 TF 1838A/ND 10-20 TF 1359ND	SKIN , front, side, inboard, c/w stringers, Starboard, assembly (Spares condition) Spares for :— STRINGER , Port (Make from standard section J.755, Ref. No. 26FY/1659)	1 1	— —	C LM	C RC9

**TAIL UNIT
FIN AND TAIL BOOM**

Ref No	Part No	Description	No off	Material Specification	Class of Store or L.M	Plate No.
	10-20 TF 1647ND	STRINGER , Port (Make from standard section J.258 Ref. No. 26FY/1656)	1	—	LM	RC9
	10-20 TF 1649ND	STRINGER , Port (Make from standard section J.258 Ref. No. 26FY/1656)	1	—	LM	RC9
	10-20 TF 1360ND	STRINGER , Starboard (Make from standard section J.755 Ref. No. 26FY/1659)	1	—	LM	RC9
	10-20 TF 1648ND	STRINGER , Starboard (Make from standard section J.258 Ref. No. 26FY/1656)	1	—	LM	RC9
	10-20 TF 1650ND	STRINGER , Starboard (Make from standard section J.258 Ref. No. 26FY/1656)	1	—	LM	RC9
	10-20 TF 1343ND	SKIN , nose, Port and Starboard, 16 SWG (For spares use 10-20 TF 1839ND)	1	DTD.746	—	RC9
14607	10-20 TF 1839ND	SKIN , nose, Port and Starboard, 16 SWG (Spares condition)	1	DTD.746	C	
7488	10-20 TF 587A/ND	SKIN , rear, side, inboard, c/w stringers, Port, assembly	1	—	C	RC9
7489	10-20 TF 588A/ND	SKIN , rear, side, inboard, c/w stringers, Starboard, assembly Spares for :—	1	—	C	RC9
	10-20 TF 1651ND	STRINGER , Port (Make from standard section J.258 Ref. No. 26FY/1656)	1	—	LM	RC9
	10-20 TF 1652ND	STRINGER , Starboard (Make from standard section J.258 Ref. No. 26FY/1656)	1	—	LM	RC9
7490	10-20 TF 583A/ND	SKIN , side, outboard, c/w stringers, Port, assembly	1	—	C	RC9
7491	10-20 TF 584A/ND	SKIN , side, outboard, c/w stringers, Starboard, assembly Spares for :—	1	—	C	RC9
	10-20 TF 1351ND	STRINGER , Port (Make from standard section J.258 Ref. No. 26FY/1656)	1	L.73	LM	RC9
	10-20 TF 1353ND	STRINGER , Port (Make from standard section J.258 Ref. No. 26FY/1656)	1	L.73	LM	RC9
	10-20 TF 1355ND	STRINGER , Port (Make from standard section J.258 Ref. No. 26FY/1656)	1	L.73	LM	RC9
	10-20 TF 1357ND	STRINGER , Port (Make from standard section J.258 Ref. No. 26FY/1656)	1	L.73	LM	RC9
	10-20 TF 1352ND	STRINGER , Starboard (Make from standard section J.258 Ref. No. 26FY/1656)	1	L.73	LM	RC9
	10-20 TF 1354ND	STRINGER , Starboard (Make from standard section J.258 Ref. No. 26FY/1656)	1	L.73	LM	RC9
	10-20 TF 1356ND	STRINGER , Starboard (Make from standard section J.258 Ref. No. 26FY/1656)	1	L.73	LM	RC9
	10-20 TF 1358ND	STRINGER , Starboard (Make from standard section J.258 Ref. No. 26FY/1656)	1	L.73	LM	RC9
	10-20 TF 1175A	SPAR , fin, Port, assembly (For spares use 10-20 TF 2009A/ND)	1	—	—	RC3
16419	10-20 TF 2009A/ND	SPAR , fin, Port, assembly (Spares condition) ...	1	—	P	
	10-20 TF 1176A	SPAR , fin, Starboard, assembly (For spares use 10-20 TF 2010A/ND)	1	—	—	RC3
16420	10-20 TF 2010A/ND	SPAR , fin, Starboard, assembly (Spares condition) Spares for :—	1	—	P	
28M/9435560	AGS.2007/E/1	NUT , 1/2" BSF, anchor	9	—	C	
28M/9435649	AGS.2018/E/1	NUT , 1/4" BSF, anchor	1	—	C	
	10-20 TF 609	STIFFENER , between stringers "C" and "D" and fin diaphragm, inner skin, Port	1	L.73	LM	RC9

**TAIL UNIT
FIN AND TAIL BOOM**

Ref. No.	Part No.	Description	No. off	Material Specification	Class of Store or L.M	Plate No.
	10 TF 1744ND	STIFFENER , between stringers "C" and "D" and fin diaphragm, outer skin, Starboard	1	L.73	LM	RC9
	10 TF 1743ND	STIFFENER , between stringers "C" and "D" and fin, diaphragm, outer skin, Port, and inner skin, Starboard	1	L.73	LM	RC9
	10-20 TF 613ND	STIFFENER , fin joint to boom, outer skin, Port, 16 SWG	1	L.73	LM	RC9
	10-20 TF 615ND	STIFFENER , fin joint to boom, outer skin, Port, 16 SWG	1	L.72	LM	RC9
	10-20 TF 614ND	STIFFENER , fin joint to boom, outer skin, Starboard, 16 SWG	1	L.72	LM	RC9
	10-20 TF 616ND	STIFFENER , fin joint to boom, outer skin, Starboard, 16 SWG	1	L.72	LM	RC9
6340	10 TF 1677A	STIFFENER , inner skin, at rudder mass balance access hole, Port, assembly	1	—	C	RC9
	10-20 TF 765A	STIFFENER , inner skin, at rudder mass balance access hole, Starboard, assembly Attachments for 10 TF 1677A or 10-20 TF 765A, Stiffener :—	1	—	—	RC9
4161	DHS.365/4½C	Bolt, 2 BA	4	—	—	RC9
28M/13591	A24/CP	Nut, 2 BA	4	—	C	RC9
	10-20 TF 1777ND	Washer, special, tapered, 14 SWG × 0"50 × 0"50	4	L.72	—	RC9
	10 TF 1675A	STIFFENER , outer skin, at rudder mass balance access hole, Port and Starboard, 18 SWG	2	—	LM	RC9
17355	10-20 TF 2029	STOP , rudder balance weight lever, inboard ...	1	DTD.304	C	RC2
14995	10-20 TF 1815	STOP , rudder balance weight lever, outboard ... Attachments for 10-20 TF 1815 or 10-20 TF 2029, Stop :—	1	DTD.304	C	RC2
15286	DHS.365/7C	Bolt, 2 BA	1	—	C	RC2
6759	DHS.365/8C	Bolt, 2 BA	1	—	C	RC2
28M/10288	AGS.2001/C/1	Nut, 2 BA	1	—	C	
28M/10328	AGS.2002/C/1	Nut, 2 BA	1	—	C	
28W/9419454	SP.10/C	Washer, facing ...	6	—	C	
	10-20 TF 1349ND	STRINGER , nose, Port (Make from section J.258 Ref. No. 26FY/1656)	1	—	LM	RC9
	10-20 TF 1350ND	STRINGER , nose, Starboard (Make from section J.258 Ref. No. 26FY/1656)	1	—	LM	RC9
	10-20 TF 1391	STRIP , bearing, reinforcement at access hole, tail-plane booster, Port and Starboard, 14 SWG	1	L.72	LM	RC9
7482	10-20 TF 563	STRIP , reinforcing, at fin spar, from fin/boom joint to centre hinge bracket, rudder, inner skin, Port and Starboard	1	DTD.746	C	RC9
7481	10-20 TF 561	STRIP , reinforcing, at fin spar, from fin/boom joint to centre hinge bracket, outer skin Port and Starboard, 16 SWG	1	DTD.746	C	RC9

**TAIL UNIT
FIN AND TAIL BOOM**

Ref. No.	Part No.	Description	No. off	Material Specification	Class of Store or L.M	Place No.
14397	10-20 TF 1211A	SUPPORT , oleo, upper end, tail bumper, Port, assembly	1	—	C	RC2
14398	10-20 TF 1212A	SUPPORT , oleo, upper end, tail bumper, Starboard, assembly	1	—	C	RC2
1606	10-20 TF 1215	BUSH (See Repair section PA)	2	—	C	RC2
28M/11957	AGS.2007/C/1	NUT , 2 BA, anchor	8	—	C	
	DHS.877/C16	PLATE , packing	2	—	—	RC2
		Attachments for 10-20 TF 1211A or 10-20 TF 1212A, Support :—				
28D/9133012	A25/3C	Bolt, 2 BA, at fin spar	5	—	C	
	4371	Bolt, 2 BA	60	—	C	RC2
	2742	Bolt, 2 BA	12	—	C	RC2
28M/10288	AGS.2001/C/1	Nut, 2 BA	42	—	C	
28M/9403520	A27/CP	Nut, 2 BA	30	—	C	
28W/9419402	SP.13/C	Washer	72	—	C	
8008	10-20 TF 811A/1	TUBE , fairlead, elevator cable, Port and Starboard, assembly	1	—	C	RC5
1596	10 TF 1735	TUBE , fairlead, elevator cable, Port and Starboard	1	—	C	RC5
28W/9419404	SP.16/C	WASHER , at intersection of fin rib No. 10 and stringer "A"	4	—	C	
28W/9419475	SP.15/C	WASHER , for attachments at main fin rib, forward diaphragm, and rib No. 11	10	—	C	
		Attachments for 10-20 TF 1943 or 10-20 TF 1945, Fin :— At Rudder centre hinge :—				
28D/9436920	A25/1C	Bolt, 2 BA	2	—	C	
	9619	Bolt	1	—	C	RC2
	5K/3403	Lead, bonding, flexible	1	—	C	
28M/10288	AGS.2001/C/1	Nut, 2 BA	2	—	C	
28M/5808571	A27/GS	Nut, 3/8" BSF	1	—	C	
28P/9527619	SP.90/C7	Pin, split (SP.9/C8)	1	—	C	
28W/9419402	SP.13/C	Washer	2	—	C	
28W/9419403	SP.13/G	Washer	1	—	C	
		At Rudder top and bottom hinges :—				
28D/1213749	A30/23E	Bolt, 3/4" BSF	2	—	C	
28M/1011467	A27/ES	Nut, 1/2" BSF	2	—	C	
28P/9527619	SP.90/C7	Pin, split (SP.9/C8)	2	—	C	
28W/9418921	SP.13/E	Washer	2	—	C	
	—	SERVICES (See sub-sections QJ, QP and QS)	—	—	—	
		Note:—The Fin and Tail Boom Spares assembly is supplied complete with all Services except for the following items :—				
		Fuel vent pipes, connector, and attachments forward of diaphragm, Stn. 379"55, Port				
		Hydraulic accumulator assemblies, accumulators, pressure gauges, charging valves, banjo bolts and sealing washers, Port and Starboard				

**TAIL UNIT
FIN AND TAIL BOOM**

Ref. No.	Part No.	Description	No. of						Material Specification	Class of Store or L.M	Plate No.
			1	2	3	4	5	6			
	10-20 TB 1301A	TAIL BOOM , Port, assembly (Pre Mod. 7) ...	1						—	RC10	
	10-20 TB 1699A	TAIL BOOM , Port, assembly (Mod. 7) ...	1						—	RC10	
	10-20 TB 1303A	TAIL BOOM , Starboard, assembly ...	1						—	RC10	
	—	Spares for :—									
	10-20 TB 689A/ND	BEAM , support, cable, at frame No. 3, Port, group (Drg. No. 10-20 TB 687)	1						—	RC12	
	10-20 TB 691	BEAM , assembly ...	1						—	RC12	
	10-20 TB 693	CHANNEL , beam, 20 SWG ...	1					L.72	—	RC12	
		CHANNEL , fairlead mounting, 20 SWG	1					L.72	LM	RC12	
		Attachments for 10-20 TB 689A/ND, Beam :—									
28D/9138768	A25/1/2 C	Bolt, 2 BA ... (Pre Mod. 7) ...	5					—	C		
		(Mod. 7) ...	6					—	C		
28M/9403520	A27/CP	Nut, 2 BA ... (Pre Mod. 7) ...	5					—	C		
		(Mod. 7) ...	6					—	C		
	10-20 TB 143	FAIRLEAD , upper, on mounting channel ...	1					LFS.21	LM	RC12	
		Attachments for 10-20 TB 143, Fairlead :—									
28D/1011019	A25/8C	Bolt, 2 BA ...	2					—	C		
28M/10288	AGS.2001/C/1	Nut, 2 BA ...	2					—	C		
	10-20 TB 145	FAIRLEAD , lower, on mounting channel ...	1					LFS.21	LM	RC12	
		Attachments for 10-20 TB 145, Fairlead :—									
28D/9133013	A25/5C	Bolt, 2 BA ...	2					—	C		
28M/9403520	A27/CP	Nut, 2 BA ...	2					—	C		
	10-20 TB 695	FAIRLEAD , vertical, on beam channel ...	1					LFS.21	LM	RC12	
		Attachments for 10-20 TB 695, Fairlead :—									
28D/9133013	A25/5C	Bolt, 2 BA ...	2					—	C		
28M/9403520	A27/CP	Nut, 2 BA ...	2					—	C		
	10-20 TB 697	FAIRLEAD , horizontal, on beam channel ...	2					LFS.21	LM	RC12	
		Attachments for 10-20 TB 697, Fairlead :—									
28D/9140647	A25/14C	Bolt, 2 BA ...	2					—	C		
28M/10288	AGS.2001/C/1	Nut, 2 BA ...	2					—	C		
	—	BEAM , support, cable, at frame No. 3, Starboard, group (Drg. No. 10-20 TB 699)	1					—	—	RC12	
	10-20 TB 701	CHANNEL , beam, 20 SWG ...	1					L.72	LM	RC12	
		Attachments for 10-20 TB 701, Channel :—									
28D/9138768	A25/1/2 C	Bolt, 2 BA ...	4					—	C		
28M/9403520	A27/CP	Nut, 2 BA ...	4					—	C		
	10-20 TB 143	FAIRLEAD , upper ...	1					LFS.21	LM	RC12	
		Attachments for 10-20 TB 143, Fairlead :—									
28D/1011019	A25/8C	Bolt, 2 BA ...	2					—	C		
28M/10288	AGS.2001/C/1	Nut, 2 BA ...	2					—	C		
	10-20 TB 145	FAIRLEAD , lower ...	1					LFS.21	LM	RC12	
		Attachments for 10-20 TB 145, Fairlead :—									
28D/9133013	A25/5C	Bolt, 2 BA ...	2					—	C		
28M/9403520	A27/CP	Nut, 2 BA ...	2					—	C		

**TAIL UNIT
FIN AND TAIL BOOM**

Ref. No.	Part No.	Description	No. off						Material Specification	Class of Store or L.M	Place No.
			1	2	3	4	5	6			
	10-20 TB 1793A	BRACKET , attachment, forward lower, for panel coded "UF," forward of frame No. 1 (Mod. 740) Spares for :—	1						—	—	RC16
28M/11957	10-20 TB 1795ND	BRACKET , bare, 18 SWG	1					L.72	LM	RC16	
	AGS.2007/C/1	NUT , anchor, 2 BA	1					—	C		
	10-20 TB 1789A	BRACKET , attachment, forward upper, for panel coded "UF," forward of frame No. 1 (Mod. 740) Spares for :—	1					—	—	RC16	
28M/11957	10-20 TB 1791ND	BRACKET , bare, 18 SWG	1					L.72	LM	RC16	
	AGS.2007/C/1	NUT , anchor, 2 BA	1					—	C		
	—	BRACKET , attachment, hinged panel, between frames No. 1 and No. 2, Port, group (Drg. No. 10-20 TB 1501)	1					—	—	RC11	
	—	BRACKET , attachment, hinged panel, between frames No. 1 and No. 2, Starboard, group (Drg. No. 10-20 TB 1502)	1					—	—	RC11	
	10-20 TB 777	ANGLE , bracket attachment, at frames No. 1 and No. 2, 18 SWG	2					L.72	LM	RC11	
28M/9993192	10-20 TB 769A	BRACKET , attachment, assembly	1					—	—	RC11	
	10-20 TB 773ND	ANGLE , reinforcing, 18 SWG	2					L.72	LM	RC11	
	10-20 TB 771ND	BRACKET , bare, 20 SWG	1					L.72	LM	RC11	
	AGS.2009/C/1	NUT , anchor, 2 BA	2					—	C		
	10-20 TB 1567A	BRACKET , attachment, telebrief plug mounting bracket, between frames No. 3 and No. 4, Port, upper, assembly	1					—	—	RC12	
	10-20 TB 1568A	BRACKET , attachment, telebrief plug mounting bracket, between frames No. 3 and No. 4, Starboard, upper, assembly	1					—	—	RC12	
28M/11957	10-20 TB 1569ND	BRACKET , Port, 16 SWG	1					L.72	LM	RC12	
	10-20 TB 1570ND	BRACKET , Starboard, 16 SWG	1					L.72	LM	RC12	
	AGS.2007/C/1	NUT , anchor, 2 BA	2					—	C		
	10-20 TB 1573	BRACKET , attachment, telebrief plug mounting bracket, between frames No. 3 and No. 4, Port, lower, 16 SWG	1					L.72	LM	RC12	
	10-20 TB 1574	BRACKET , attachment, telebrief plug mounting bracket, between frames No. 3 and No. 4, Starboard, lower, 16 SWG	1					L.72	LM	RC12	
	10-20 TB 1345A	BRACKET , mounting, between frames No. 1 and No. 2, for hinged terminal panel, Port and Starboard inboard, assembly	2					—	—	RC12	
28M/13307	10-20 TB 1343ND	BRACKET , bare, 18 SWG	1					L.72	LM	RC12	
	AGS.2018/B/1	NUT , anchor, 4 BA	2					—	C		
	10-20 TB 1823A	BRACKET , pivot, tail bumper, assembly (Mod. 724) (For spares use 10-20 TB 1815A/ND)	1					—	—	RC13	
15113	10-20 TB 1815A/ND	BRACKET , pivot, tail bumper, assembly (Spares condition)	1					—	C		
	10-20 TB 2117A	BRACKET , joint, aft, assembly (For spares use 10-20 TB 1741A/ND)	1					—	—	RC13	
14536	10-20 TB 1741A/ND	BRACKET , joint, aft, assembly (Spares condition)	1					—	P		
28D/1200119	A25/4C	Attachments for 10-20 TB 2117A, Bracket :—									
28M/9403520	A27/CP	Bolt, 2 BA	8					—	C		
28W/9419402	SP.13/C	Nut, 2 BA	8					—	C		
		Washer	8					—	C		

**TAIL UNIT
FIN AND TAIL BOOM**

Ref. No.	Part No.	Description						No. off	Material Specification	Class of Store or L.M.	Plate No.
		1	2	3	4	5	6				
	10-20 TB 323							2	DTD.197	—	RC13
	10-20 TB 313							1	L.65	—	RC13
	10-20 TB 314							1	L.65	—	RC13
28D/1200119	A25/4C							4	—	C	
1147	DHS.358/3E							6	—	C	RC13
2348	DHS.358/4E							8	—	C	RC13
2248	DHS.358/5E							6	—	C	RC13
2341	DHS.358/6E							6	—	C	RC13
28M/9403520	A27/CP							4	—	C	
28M/12928	A27/EP							26	—	C	
28W/9419402	SP.13/C							4	—	C	
28W/7000392	SP.14/E							36	—	C	
	—										
								1	—	—	
	10-20 TB 1721A							1	—	—	RC12
	10-20 TB 1727ND							1	L.72	LM	RC12
	10-20 TB 1723ND							1	L.72	LM	RC12
28M/9434253	AGS.2007/B/1							4	—	C	
	—							1	—	—	RC12
	10-20 TB 1493A							1	—	—	RC12
	10-20 TB 1495ND							1	L.72	LM	RC12
28M/12421	AGS.2018/C/1							2	—	C	
	10-20 TB 1497A							1	—	—	RC12
	10-20 TB 1499ND							1	L.72	LM	RC12
28M/12421	AGS.2018/C/1							2	—	C	
15709	10-20 R 3611A							1	—	C	RC19
15710	10-20 R 3612A							1	—	C	RC19
17088	10-20 TB 1797A							1	—	C	RC16
28M/9434251	AGS.2008/B/1							7	—	C	
	10-20 TB 779							1	—	—	RC10
	10-20 TB 780							1	—	—	RC10
	10-20 TB 531							1	L.72	—	RC10
	10-20 TB 532							1	L.72	—	RC10

**TAIL UNIT
FIN AND TAIL BOOM**

Ref. No.	Part No.	Description	No. off	Material Specification	Class of Score or L.M	Plate No.
	10-20 TB 1127ND	CHANNEL-FAIRING , tail boom to fin bottom joint, between frame No. 6 and fin (For spares use 10-20 TB 1523ND)	1	—	—	RC10
11124	10-20 TB 1523ND	CHANNEL-FAIRING , tail boom to fin bottom joint, between frame No. 6 and fin (Spares condition)	1	—	C	
		Attachments for 10-20 TB 1127ND, Channel-Fairing :—				
7199	DHS.358/1½C	Bolt, 2 BA	12	—	C	RC10
1654	DHS.358/2C	Bolt, 2 BA	32	—	C	RC10
2347	DHS.358/3½C	Bolt, 2 BA	11	—	C	RC10
1660	DHS.358/4C	Bolt, 2 BA	2	—	C	RC10
3815	DHS.358/4½C	Bolt, 2 BA	22	—	C	RC10
28M/9403520	A27/CP	Nut, 2 BA	64	—	C	
28W/9128924	SP.14/C	Washer	10	—	C	
	10-20 TB 333A	CHANNEL , stiffener, tail bumper pivot bracket, assembly (For spares use 10-20 TB 5043A/ND)	1	—	—	RC13
20170	10-20 TB 5043A/ND	CHANNEL , stiffener, tail bumper pivot bracket, assembly (Spares condition)	1	—	C	
	10-20 TB 335ND	CHANNEL , bare, 18 SWG	1	L.72	LM	RC13
28M/11957	AGS.2007/C/1	NUT , anchor, 2 BA	18	—	C	
	10-20 TB 493ND	PLATE , packing, under anchor nuts, aft, L.H., 12 SWG	1	L.72	LM	RC13
	10-20 TB 494ND	PLATE , packing, under anchor nuts, aft, R.H., 12 SWG	1	L.72	LM	RC13
	10-20 TB 1673A	COVER-DOOR , access, telebrief plug, between frames No. 3 and No. 4, Port, assembly	1	—	—	RC14
	10-20 TB 1674A	COVER-DOOR , access, telebrief plug, between frames No. 3 and No. 4, Starboard, assembly	1	—	—	RC14
		Spares for :—				
		BRACKET , trunnion mounting, group	1	—	—	
28D/9435711	A25/10B	BOLT , 4 BA, bracket end closing	2	—	C	
13122	10-20 TB 1563	BRACKET , trunnion mounting	1	—	C	RC14
28M/1006504	A27/BT	NUT , 4 BA	2	—	C	
28M/10326	AGS.2002/A/1	NUT , 6 BA	2	—	C	
28S/1200060	A33/A16	SCREW , 6 BA	2	—	C	
	AS.2810/4/086	TUBE , distance, ½" o/d x 20 SWG x 0"86 long	2	L.62	LM	RC14
28W/9480389	SP.26/B	WASHER	2	—	C	
28W/9403515	SP.26/A	WASHER	2	—	C	
13123	10-20 TB 1565	GUIDE , spring	1	—	C	RC14
		Attachments for 10-20 TB 1565, Guide :—				
28P/816	SP.4/Y/A6	Pin, shackle	1	—	C	RC14
28P/9527619	SP.90/C7	Pin, split (SP.9/C8)	1	—	C	
	10-20 TB 1589ND	HINGE , door, Port (Make from Part No. AS.1879, Ref. No. 28N/16453)	1	L.72	LM	RC14
	10-20 TB 1590ND	HINGE , door, Starboard (Make from Part No. AS.1879, Ref. No. 28N/16453)	1	L.72	LM	RC14
13127	10-20 TB 1575A	LEVER , door, assembly	1	—	C	RC14
	10-20 TB 1591ND	PLATE , cover, Port (For spares use 10-20 TB 1809ND)	1	—	—	RC14

**TAIL UNIT
FIN AND TAIL BOOM**

Ref. No.	Part No.	Description	No. off	Material Specification	Class of Score or L.M	Plate No.
14714	10-20 TB 1809ND 10-20 TB 1592ND	PLATE , cover, Port (Spares condition) ... PLATE , cover, Starboard (For spares use 10-20 TB 1810ND)	1 1	— —	C —	RC14
14715	10-20 TB 1810ND	PLATE , cover, Starboard (Spares condition)	1	—	C	
13126	10-20 TB 1607	SEAL , door, $\frac{1}{16}$ " thick, shore hardness 30°	1	Neoprene	LM	RC14
13125	10-20 TB 1587	SEATING , spring	1	—	C	RC14
13125	10-20 TB 1583	SPRING	1	—	C	RC14
13124	10-20 TB 1585	TRUNNION	1	—	C	RC14
		Attachments for 10-20 TB 1673A or 10-20 TB 1674A, Cover-Door :—				
28D/1214091	AS.1242/2C	Bolt, 2 BA	22	—	C	
8244	10-20 TB 1065	COVER , access, handhole, between frames No. 1 and No. 2, Port, inboard Attachments for 10-20 TB 1065, Cover :—	1	—	C	RC14
28D/9709461	AS.1242/3C	Bolt, 2 BA	38	—	C	
8245	10-20 TB 1067A	COVER , access, flush air intake, inverter cooling, Port, outboard, Starboard, inboard, assembly	1	—	C	RC14
8246	10-20 TB 1068A	COVER , access, flush air intake, inverter cooling, Starboard, outboard Attachments for 10-20 TB 1067A or 10-20 TB 1068A, Cover :—	1	—	C	RC14
28D/9709461	AS.1242/3C	Bolt, 2 BA	38	—	C	
17502	10-20 TB 5031A	COVER-PLATE , access, for handhole, between frames No. 5 and No. 6, Port, assembly (Mod. 933)	1	—	C	RC14
17503	10-20 TB 5032A	COVER-PLATE , access, for handhole, between frames No. 5 and No. 6, Starboard, assembly (Mod. 933)	1	—	C	RC14
17504	10-20 TB 5003A	PANEL , assembly Attachments for 10-20 TB 5003A, Panel :—	1	—	C	RC14
20807	10-20 EC 8295A	Chain, assembly	1	—	C	RC14
29H/4114	—	Chain, bare, 8" long	QR	—	C	RC14
29H/	—	Ring, split, $\frac{3}{8}$ " dia.	2	Stn. Steel	C	RC14
12026	DHS.180 Mk. 1/Z	Tag	2	—	C	RC14
	10-20 TB 5029A	PLATE , cover, L.H., assembly	1	—	—	RC14
	10-20 TB 5030A	PLATE , cover, R.H., assembly Spares for :—	1	—	—	RC14
	10-20 TB 5009	LABEL , engraved, "950-1000 P.S.I." 24 SWG Attachments for 10-20 TB 5031A or 10-20 TB 5032A, Cover-plate :—	1	Alumn.	LM	
28D/1214091	AS.1242/2C	Bolt, 2 BA	22	—	C	
2294	10-20 TB 363	COVER-PLATE , access, handhole, between frame No. 7 and fin joint rib, Port, outboard, Starboard, inboard	1	—	C	RC14
2295	10-20 TB 364	COVER-PLATE , access, handhole, between frame No. 7 and fin joint rib, Port, inboard, Starboard, outboard Attachments for 10-20 TB 363 or 10-20 TB 364, Cover-Plate :—	1	—	C	RC14
28D/1007975	AS.1242/1C	Bolt, 2 BA	15	—	C	
28D/1214091	AS.1242/2C	Bolt, 2 BA	3	—	C	

TAIL UNIT
FIN AND TAIL BOOM

Ref. No.	Part No.	Description	No. off	Material Specification	Class of Store or L.M.	Plate No.
	—	DUCT , inverter cooling, tail boom, Port, group Drg. Nos. 10-20 V 47, Pre Mod. 7, 10-20 V 3603, Mod. 7)	1	—	—	RC20
	—	DUCT , inverter cooling, tail boom, Starboard group (Drg. No. 10-20 V 19)	1	—	—	RC20
	10-20 V 35	ANGLE , duct attachment, L.H., 18 SWG	1	L.72	LM	RC20
	10-20 V 36	ANGLE , duct attachment, R.H., Starboard only, 18 SWG	1	L.72	LM	RC20
		Attachments for 10-20 V 35 or 10-20 V 36, Angle :—				
28D/9436920	A25/1C	Bolt, 2 BA	3	—	C	
28M/10288	AGS.2001/C/1	Nut, 2 BA	3	—	C	
28W/9419475	SP.15/C	Washer	3	—	C	
11687	10-20 V 53A/ND	DUCT , Type 103 inverter, Port, assembly (Pre Mod. 7)	1	—	C	RC20
12898	10-20 V 26A/ND	DUCT , Type 103 inverter, Port, assembly (Mod. 7)	1	—	C	RC20
11689	10-20 V 25A/ND	DUCT , Type 103 inverter, Starboard, assembly	1	—	C	RC20
11690	10-20 V 21A/ND	DUCT , Type 108 inverter, Starboard, assembly Spares for 10-20 V 53A/ND, 10-20 V 26A/ND, 10-20 V 25A/ND, or 10-20 V 21A/ND, Duct :—	1	—	C	RC20
	10-20 V 29A	BRACKET , assembly, 20 SWG	1	L.59	LM	RC20
	10-20 V 41ND	PACKING , 0".75 wide x 10".4 long x 1/4" thick, natural rubber, Shore hardness 40°-50° (Attach with Bostik C)	1	—	LM	RC20
		Attachments for 10-20 V 53A/ND, 10-20 V 26A/ND, 10-20 V 25A/ND, or 10-20 V 21A/ND, Duct :—				
28D/9436920	A25/1C	Bolt, 2 BA	3	—	C	
28E/19825	SP.91/L	Clip, hose adjustable, Type J	2	—	C	
11688	10-20 V 43ND	Hose, 2 1/4" o/d x 2"0 i/d x 2".15 long, natural rubber	1	—	C	RC20
28M/10288	AGS.2001/C/1	Nut, 2 BA	3	—	C	
28W/9419475	SP.15/C	Washer	3	—	C	
8007	10-20 P 1071A	DUCT , outlet, fuel vent pipe, Port	1	—	C	RC13
	10-20 TB 1767A	FAIRING , tail boom, forward, assembly (Mod. 724) (For spares use 10-20 TB 2137A/ND)	1	S.514	—	RC10
15305	10-20 TB 2137A/ND	FAIRING , tail boom, forward, assembly (Spares condition)	1	—	P	
28M/11957	AGS.2007/C/1	NUT , anchor, 2 BA	4	—	C	
	10-20 TB 1781ND	STRAP , joint (Mod. 724) (For spares use 10-20 TB 2157ND)	1	S.514	—	RC11
15764	10-20 TB 2157ND	STRAP , joint (Spares condition)	1	—	C	
		Attachments for 10-20 TB 1767A, Fairing :—				
28D/1214091	AS.1242/2C	Bolt, 2 BA	20	—	C	
28D/1007976	AS.1242/4C	Bolt, 2 BA	4	—	C	
	10-20 TB 2121	FAIRING , tail boom, aft (For spares use 10-20 TB 2133ND)	1	—	—	RC10
15080	10-20 TB 2133ND	FAIRING , tail boom, aft (Spares condition)	1	—	C	
		Attachments for 10-20 TB 2121, Fairing :—				
28D/1214091	AS.1242/2C	Bolt, 2 BA	6	—	C	
28D/9709461	AS.1242/3C	Bolt, 2 BA	4	—	C	
28D/1007976	AS.1242/4C	Bolt, 2 BA	3	—	C	
	—	MOUNTING , control panel, Type 26, between frames No. 1 and No. 2, Port, group 10-20 TB 1629) (Mod. 7)	1	—	—	RC15
	—	MOUNTING , control panel, Type 26, between frames No. 1 and No. 2, Starboard, group (10-20 TB 1355) (Pre Mod. 7)	1	—	—	RC15

TAIL UNIT
FIN AND TAIL BOOM

Ref. No.	Part No.	Description	No. off						Material Specification	Class of Store or L.M	Plate No.	
			1	2	3	4	5	6				
	—	MOUNTING , control panel, Type 26, between frames No. 1 and No. 2, Starboard, group (10-20 TB 1630) (Mod. 7)							1	—	—	RC15
	10-20 TB 2181A	FRAME , mounting, control panel, Port, assembly (Mod. 740, for use on Mod. 7 A/C)							1	—	—	RC15
	10-20 TB 2182A	FRAME , mounting, control panel, Starboard, assembly (Mod. 740, for use on Mod. 7 A/C)							1	—	—	RC15
	10-20 TB 5013A/ND	Spares for:— PIN , "Pip," quick release, inboard, forward and aft, assembly							2	—	—	RC15
32A/	—	Spares for:— CORD , $\frac{3}{16}$ " dia. x 8"0 long							QR	Black nylon	C	
28FP/1048015	AGS.2105/405	PIN , "Pip," quick release							1	—	C	RC15
29H/	—	RING , split, $\frac{3}{8}$ " dia.							1	—	C	
26DL/7354	DHS.180 Mk.1/X	TAG							1	—	C	RC15
	10-20 TB 5015A/ND	PIN , "Pip," quick release, outboard, forward, assembly							1	—	—	RC15
		Spares for:— CORD , $\frac{3}{16}$ " dia. x 8"0 long							QR	Black nylon	C	
32A/	—	PIN , "Pip," quick release							1	—	C	RC15
28FP/9469298	AGS.2105/407	RING , split, $\frac{3}{8}$ " dia.							1	—	C	RC15
29H/	—	TAG							1	—	C	RC15
26DL/7354	DHS.180 Mk.1/X	PIN , "Pip," quick release, outboard, aft, assembly							1	—	—	RC15
	10-20 TB 5017A/ND	Spares for:— CORD , $\frac{3}{16}$ " dia. x 8"0 long							QR	Black nylon	C	
32A/	—	PIN , "Pip," quick release							1	—	C	RC15
28FP/9469299	AGS.2105/409	RING , split, $\frac{3}{8}$ " dia.							1	—	C	RC15
29H/	—	TAG							1	—	C	RC15
26DL/7354	DHS.180 Mk. 1/X	FRAME , mounting, control panel, Starboard, assembly (Pre Mod. 7)							1	—	P	
12038	10-20 TB 1305A	Attachments for 10-20 TB 1305A, Frame:— Bolt, 2 BA							2	—	C	
28D/1010030	A25/7C	Nut, 2 BA							2	—	C	
28M/5808573	A27/CS	Pin, split (SP.9/C8)							2	—	C	
28P/9527619	SP.90/C7	Tube, distance, $\frac{1}{4}$ " o/d x 20 SWG x 0"14 long							2	L.62	LM	
28W/9419402	AS.2810/4/014	Washer							2	—	C	
	SP.13/C											
12040	10-20 TB 1377	MOUNTING , support, for mounting frame, Starboard, secured to frame No. 1 (Pre Mod. 7)							1	—	C	RC15
17083	10-20 TB 2191	MOUNTING , support, for mounting frame, secured to frame No. 1 (Mods. 740 and 7)							1	—	C	RC15
		Attachments for 10-20 TB 1377 or 10-20 TB 2191, Mounting:— Bolt, 2 BA							4	—	C	
28D/9133011	A25/2C	Nut, 2 BA							4	—	C	
28M/9403520	A27/CP	Shim, laminated "Attewell" (Mods. 740 and 7)							QR	—	C	RC15
17082	10-20 TB 1807	Washer							4	—	C	
28W/9419402	SP.13/C											

TAIL UNIT
FIN AND TAIL BOOM

Ref. No.	Part No.	Description	No. off						Material Specification	Class of Store or L.M	Plate No.
			1	2	3	4	5	6			
17084	10-20 TB 2189	MOUNTING , support, for mounting frame, secured to frame No. 2, Port, (Mods. 740 and 7)	1						—	C	RC15
12039	10-20 TB 1375	MOUNTING , support, for mounting frame, secured to frame No. 2, Starboard (Pre Mod. 7)	1						—	C	RC15
17085	10-20 TB 2190	MOUNTING , support, for mounting frame, secured to frame No. 2, Starboard (Mods. 740 and 7)	1						—	C	RC15
		Attachments for 10-20 TB 2189, 10-20 TB 1375 or 10-20 TB 2190, Mounting :—									
28D/9133011	A25/2C	Bolt, 2 BA	2						—	C	
28M/9403520	A27/CP	Nut, 2 BA	2						—	C	
28W/9419402	SP.13/C	Washer	2						—	C	
	10-20 TB 1357ND	PLATE , attachment, upper, support strut, at frame No. 1, Starboard, 12 SWG (Pre Mod. 7)	1						L.72	LM	RC15
	10-20 TB 1358ND	PLATE , attachment, upper, support strut, at frame No. 2, Starboard, 12 SWG (Pre Mod. 7)	1						L.72	LM	RC15
	10-20 TB 1631ND	PLATE , attachment, upper, support strut, at frame No. 1, Starboard and frame No. 2, Port, 12 SWG (Mod. 7)	1						L.72	LM	RC15
	10-20 TB 1632ND	PLATE , attachment, upper, support strut, at frame No. 1, Port, frame No. 2, Starboard, 12 SWG (Mod. 7)	1						L.72	LM	RC15
	10-20 R 3569A	PLUG and Socket, bonding, assembly (Mod.117)	1						—	LM	RC15
	10-20 R 3571A/ND	LEAD , bonding, flexible, assembly... ..	1						—	—	RC15
5K/4423	PLESSEY 16/4"/0048	BRAID , flexible, tinned copper, 13"-0 long	QR						—	C	RC15
5X/3242	PLESSEY Z28147	PIN , plug, 19 amp.	1						—	C	RC15
5X/6509	—	TERMINATION , lug	1						—	C	RC15
	10-20 R 3573A/ND	LEAD , bonding, flexible, assembly... ..	1						—	—	
5K/4423	PLESSEY 16/4"/0048	BRAID , flexible, tinned copper, 13"-0 long	QR						—	C	RC15
5X/7331	PLESSEY 2CZ.109945	INSERT , socket	1						—	C	RC15
5X/6508	—	TERMINATION , lug	1						—	C	RC15
		Attachments for 10-20 R 3569A, Plug and Socket :—									
28D/1010658	A25/1B	Bolt, 4 BA	1						—	C	
28M/10287	AGS.2001/B/1	Nut, 4 BA	1						—	C	
28W/9419465	SP.13/B	Washer	1						—	C	
12041	10-20 TB 1363A	STRUT , support, mounting frame, at frame No. 1, assembly (Pre Mod. 7)	1						—	C	RC15
17086	10-20 TB 2169A	STRUT , support, mounting frame, at frame No. 1, assembly (Mods. 740 and 7)	1						—	C	RC15
12042	10-20 TB 1365A	STRUT , support, mounting frame, at frame No. 2, assembly (Pre Mod. 7)	1						—	C	RC15
17087	10-20 TB 2171A	STRUT , support, mounting frame, at frame No. 2, assembly (Mods. 740 and 7)	1						—	C	RC15
		Attachments for 10-20 TB 1363A, 10-20 TB 2169A, 10-20 TB 1365A or 10-20 TB 2171A, Strut :—									
28D/1200119	A25/4C	Bolt, 2 BA	2						—	C	
28M/5808573	A27/CS	Nut, 2 BA	2						—	C	
28P/9527619	SP.90/C7	Pin, split (SP.9,C8)	2						—	C	
28W/9419402	SP.13/C	Washer	2						—	C	

**TAIL UNIT
FIN AND TAIL BOOM**

Ref. No.	Part No.	Description	No. off	Material Specification	Class of Score or L.M.	Plate No.
	10-20 N 10375A	TRAY, mounting, control panel, assembly (For spares use 10-20 N 14151A;ND)	1	—	—	RC15
15088	10-20 N 14151A;ND	TRAY, mounting, control panel, assembly (Spares condition) Spares for:—	1	—	C	
	—	CATCH, group	2	—	—	
	10-20 N 10363	CATCH, 6 SWG	1	L.72	—	RC15
	10-20 N 10365	CIRCLIP, screw retaining, 16 SWG	1	Piano Wire	—	RC15
	10-20 N 10359	NUT, trunion type	1	S.96	—	RC15
	10-20 N 10361	SCREW	1	S.96	—	RC15
28W/9419464	SP.13:A	WASHER	1	—	C	
28W/9419403	SP.13:G	WASHER	1	—	C	
28W/9703147	AGS.163/D	WASHER, spring...	1	—	C	
12044	10-20 N 10357	DOWEL, control panel locating Attachments for 10-20 N 10357, Dowel:—	2	—	C	RC15
28M/10328	AGS.2002:C/1	Nut, 2 BA	1	—	C	
10AJ/159	—	MOUNTING, anti-vibration, front	2	—	P	RC15
10AJ/158	—	MOUNTING, anti-vibration, Type 967, rear	2	—	P	RC15
10A/17922	—	STRIP, bonding Attachments for Ref. No. 10A/17922, Strip:—	2	—	C	RC15
28D/9140202	AS.1246/1C	Bolt, 2 BA	1	—	C	
28M/10328	AGS.2002:C.1	Nut, 2 BA	1	—	C	
28W/9419402	SP.13:C	Washer	1	—	C	
28D/1212313	A25.15E	Attachments for 10-20 N 10375A, Tray:—	4	—	C	
28M/10290	AGS.2001/E/1	Nut, 1/2" BSF	4	—	C	
28W/9418921	SP.13/E	Washer	8	—	C	
	—	MOUNTING, control panel, Type 15, between frames No. 2 and No. 3, Port, group (Drg. No. 10-20 TB 1215)	1	—	—	RC16
	—	MOUNTING, control panel, Type 15, between frames No. 2 and No. 3, Starboard, group (Drg. No. 10-20 TB 1373)	1	—	—	RC16
	10-20 TB 627	BRACKET, support, upper mounting channel, secured to frame No. 3, 18 SWG, Port	1	L.72	LM	RC16
	10-20 TB 620A	CHANNEL, mounting, upper, Port, assembly	1	—	—	RC16
	10-20 TB 619A	CHANNEL, mounting, upper, Starboard, assembly Spares for:—	1	—	—	RC16
	10-20 TB 629A	BOLT-PLATE, assembly	2	—	—	RC16
	10-20 TB 633	PLATE, stud catch	2	L.64	—	RC16
28M/10288	AGS.2001:C/1	Attachments for 10-20 TB 633, Plate:— Nut, 2 BA	2	—	C	
	10-20 TB 625	CHANNEL, mounting, lower, Port	1	L.72	—	RC16
	10-20 TB 626	CHANNEL, mounting, lower, Starboard	1	L.72	—	RC16
28M/9435560	AGS.2007/E/1	NUT, anchor, 1/2"BSF, secured to lower mounting channel	2	—	C	
	—	MOUNTING, inverters Type 103 and Type 112, between frames No. 1 and No. 3 Port, group (Drg. No. 10-20 TB 1489) (Mod. 7)	1	—	—	RC17

**TAIL UNIT
FIN AND TAIL BOOM**

Ref. No.	Part No.	Description	No. off	Material Specification	Class of Store or L.M.	Plate No.
	—	MOUNTING , inverters Type 103 and Type 108, between frames No. 1 and No. 3, Starboard, group (Drg. No. 10-20 TB 1225)	1	—	—	RC17
	10-20 TB 1615A	BEAM , side, inboard, table mounting, Port, assembly (Mod. 7)	1	—	—	RC17
	10-20 TB 551A	BEAM , side, inboard, table mounting, Starboard, assembly	1	—	—	RC17
	10-20 TB 583ND	BLOCK , packing	3	LFS.21	LM	
	10-20 TB 585ND	BLOCK , packing, forward, Starboard ... Attachments for 10-20 TB 583ND or 10-20 TB 581ND, Block :—	1	LFS.21	LM	
28D/9419452	A25/3B	Bolt, 4 BA	2	—	C	
28M/10287	AGS.2001/B/1	Nut, 4 BA	2	—	C	
28W/9419465	SP.13/B	Washer	2	—	C	
	10-20 TB 1613ND	CHANNEL , beam, bare, Port, 16 SWG	1	L.72	LM	RC17
	10-20 TB 581ND	CHANNEL , beam, bare, Starboard, 16SWG Attachments for 10-20 TB 1615A or 10-20 TB 551A, Beam :—	1	L.72	LM	RC17
28D/9140638	A25/4B	Bolt, 4 BA, at frame No. 1, Port	2	—	C	
28D/9436920	A25/1C	Bolt, 2 BA, at frame No. 2 or No. 3	3	—	C	
28D/12531	A25/3C	Bolt, 2 BA, at frame No. 1, Starboard	2	—	C	
28D/1200119	A25/4C	Bolt, 2 BA, at frame No. 3	1	—	C	
28M/10287	AGS.2001/B/1	Nut, 4 BA, Port	2	—	C	
28M/10288	AGS.2001/C/1	Nut, 2 BA, Port	6	—	C	
	10-20 TB 575ND	Starboard	8	—	C	
	10-20 TB 575ND	Plate, packing, at frame No. 1, Starboard, 12 SWG	1	L.72	LM	RC17
28W/9419474	SP.15/B	Washer, Port	2	—	C	
28W/9419475	SP.15/C	Washer	6	—	C	
28W/9419404	SP.16/C	Washer, Starboard	2	—	C	
	10-20 TB 1245	BRACKET , attachment, side beam secured to frame No. 1, Port, 18 SWG	1	L.72	LM	RC17
	10-20 TB 1246	BRACKET , attachment, side beam, secured to frame No. 1, Starboard, 18 SWG	1	L.72	LM	RC17
	10-20 TB 1247	BRACKET , attachment, side beam, secured to frames No. 2 and No. 3, Port, 18 SWG	2	L.72	LM	RC17
	10-20 TB 1248	BRACKET , attachment, side beam, secured to frames No. 2 and No. 3, Starboard, 18 SWG Attachments for 10-20 TB 1245, 10-20 TB 1246, 10-20 TB 1247 or 10-20 TB 1248, Bracket :—	2	L.72	LM	RC17
28D/9436920	A25/1C	Bolt, 2 BA At frame No. 1	3	—	C	
		At frames Nos. 2 and 3	2	—	C	
28M/10288	AGS.2001/C/1	Nut, 2 BA	2	—	C	
28W/9419475	SP.15/C	Washer	2	—	C	
	10-20 TB 1703A	BRACKET , side, outboard, table mounting, between frames No. 1 and No. 2, Port, assembly (Mod. 7)	1	—	—	RC17

**TAIL UNIT
FIN AND TAIL BOOM**

Ref. No.	Part No.	Description	No. off	Material Specification	Class of Store or L.M.	Plate No.
	10-20 TB 1233A	BRACKET , side, outboard, table mounting, between frames No. 1 and No. 2, Starboard, assembly (Pre Mod. 7)	1	—	—	RC17
	10-20 TB 1704A	BRACKET , side, outboard, table mounting, between frames No. 1 and No. 2, Starboard, assembly (Mod. 7)	1	—	—	RC17
	10-20 TB 1711ND	BRACKET , angle, reinforcing, forward, Port, 18 SWG	1	L.72	LM	RC17
	10-20 TB 593ND	BRACKET , angle, reinforcing, rear, 18 SWG	1	L.72	LM	RC17
	10-20 TB 1705ND	BRACKET , bare, Port, 18 SWG	1	L.72	LM	RC17
	10-20 TB 1235ND	BRACKET , bare, Starboard, 18 SWG ... (Pre Mod. 7)	1	L.72	LM	RC17
	10-20 TB 1706ND	BRACKET , bare, Starboard, 18 SWG ... (Mod. 7)	1	L.72	LM	RC17
28M/9435560	AGS.2007/E/1	NUT , anchor, 1/8" BSF, Port	2	—	C	
		Starboard	1	—	C	
	10-20 TB 1707A	BRACKET , side, outboard, table mounting, between frames No. 2 and No. 3, Port, assembly (Mod. 7)	1	—	—	RC17
	10-20 TB 1237A	BRACKET , side, outboard, table mounting, between frames No. 2 and No. 3, Starboard, assembly (Pre Mod. 7)	1	—	—	RC17
	10-20 TB 1708A	BRACKET , side, outboard, table mounting, between frames No. 2 and No. 3, Starboard, assembly (Mod. 7)	1	—	—	RC17
	10-20 TB 1711ND	BRACKET , angle, reinforcing, forward, Port, 18 SWG	1	L.72	LM	RC17
	10-20 TB 595ND	BRACKET , angle, reinforcing, forward, Starboard, 18 SWG (Pre Mod. 7)	1	L.72	LM	RC17
	10-20 TB 593ND	BRACKET , angle, reinforcing, rear, 18 SWG	1	L.72	LM	RC17
	10-20 TB 1709ND	BRACKET , bare, Port, 18 SWG	1	L.72	LM	RC17
	10-20 TB 1239ND	BRACKET , bare, Starboard, 18 SWG ... (Pre Mod. 7)	1	L.72	LM	RC17
	10-20 TB 1710ND	BRACKET , bare, Starboard, 18 SWG ... (Mod. 7)	1	L.72	LM	RC17
28M/9435560	AGS.2007/E/1	NUT , anchor, 1/8" BSF	2	—	C	
		BRACKET , mounting, inverter table, secured to forward face of frame No. 1, Starboard group	1	—	—	
	10-20 TB 1679	BRACKET , 16 SWG	1	L.72	—	RC17
28M/12249	AGS.2007/E/1	NUT , anchor, 1/8" BSF	1	—	C	
		BRACKET , attachment, lower, secured to forward face of frame No. 2 for table side mounting bracket, Port, 18 SWG	1	L.72	LM	RC17
	10-20 TB 567	BRACKET , attachment, lower, secured to forward face of frame No. 2, for table side mounting bracket, Starboard, 18 SWG	1	L.72	LM	RC17
	10-20 TB 568	BRACKET , attachment, lower, secured to forward face of frame No. 3, for table side mounting bracket, Port, 18 SWG	1	L.72	LM	RC17
	10-20 TB 1713	BRACKET , attachment, lower, secured to forward face of frame No. 3, for table side mounting bracket, Starboard, 18 SWG	1	L.72	LM	RC17
	10-20 TB 933	BRACKET , attachment, lower, secured to forward face of frame No. 3, for table side mounting bracket, Starboard, 18 SWG (Pre Mod. 7)	1	L.72	LM	RC17

**TAIL UNIT
FIN AND TAIL BOOM**

Ref. No.	Part No.	Description	No. off	Material Specification	Class of Store or L.M	Plate No.
	10-20 TB 1714	BRACKET , attachment, lower, secured to forward face of frame No. 3, for table side mounting bracket, Starboard, 18 SWG (Mod. 7)	1	L.72	LM	RC17
	10-20 TB 571ND	CLEAT , attachment, lower, secured to aft face of frame No. 2 for table side mounting bracket, 18 SWG	1	L.72	LM	RC17
	10-20 TB 573ND	CLEAT , attachment, upper, secured to aft face of frame No. 2, Port and forward face of frame No. 2, Starboard, for table side mounting bracket, 18 SWG	1	L.72	LM	RC17
	10-20 TB 577ND	CLEAT , attachment, upper, secured to forward face of frame No. 3 for table side mounting bracket, Port, 18 SWG	1	L.72	LM	RC17
28M/11957	AGS.2007/C/1	TABLE , inverter mounting, Port, group	1	—	—	
28M/12421	AGS.2018/C/1	NUT , anchor, 2 BA	15	—	C	
	10-20 TB 1593A	NUT , anchor, 2 BA	4	—	C	
		TABLE , assembly	1	—	—	RC17
28D/9140202	AS.1246/1C	Attachments for 10-20 TB 1593A, Table :— Bolt, 2 BA	19	—	C	
28M/11957	AGS.2007/C/1	TABLE , inverter, mounting, Starboard, group	1	—	—	
28M/12421	AGS.2018/C/1	NUT , anchor, 2 BA	16	—	C	
	10-20 TB 1253A	NUT , anchor, 2 BA	5	—	C	
		TABLE , assembly	1	—	—	RC17
28D/9140202	AS.1246/1C	Attachments for 10-20 TB 1253A, Table :— Bolt, 2 BA	21	—	C	
	—	MOUNTING , inverter Type 103, between frames No. 1 and No. 2, Port, group (Drg. No. 10-20 TB 1223) (Pre Mod. 7)	1	—	—	RC16
	10-20 TB 533A	BEAM , side, inboard, table mounting, assembly	1	—	—	RC16
	10-20 TB 583ND	BLOCK , packing	2	LPS.21	LM	RC16
	10-20 TB 579ND	CHANNEL , beam, bare, 16 SWG	1	L.72	LM	RC16
28M/9435560	AGS.2007/E/1	NUT , anchor, 1/4" BSF	2	—	C	
		Attachments for 10-20 TB 553A, Beam :—				
28D/9436920	A25/1C	Bolt, 2 BA	3	—	C	
28D/1200119	A25/4C	Bolt, 2 BA	1	—	C	
28M/10288	AGS.2001/C/1	Nut, 2 BA	4	—	C	
28W/9419402	SP.13/C	Washer	4	—	C	
	10-20 TB 1245	BRACKET , attachment, side beam, secured to frame No. 1, 18 SWG	1	L.72	LM	RC16
		Attachments for 10-20 TB 1245, Bracket :—				
28D/9436920	A25/1C	Bolt, 2 BA	3	—	C	
28M/10288	AGS.2001/C/1	Nut, 2 BA	3	—	C	
28W/9419475	SP.15/C	Washer	3	—	C	
	10-20 TB 1247	BRACKET , attachment, side beam, secured to frame No. 2, 18 SWG	1	L.72	LM	RC16
		Attachments for 10-20 TB 1247, Bracket :—				
28D/9436920	A25/1C	Bolt, 2 BA	2	—	C	
28M/10288	AGS.2001/C/1	Nut, 2 BA	2	—	C	
28W/9419475	SP.15/C	Washer	2	—	C	

**TAIL UNIT
FIN AND TAIL BOOM**

Ref. No.	Part No.	Description						No. off	Material Specification	Class of Store or L.M.	Plate No.
		1	2	3	4	5	6				
	10-20 TB 1229A							1	—	—	RC16
	10-20 TB 593ND							2	L.72	LM	RC16
	10-20 TB 1231ND							1	L.72	LM	RC16
28M/9993192	AGS.2009/C/1							10	—	C	
28M/9435560	AGS.2007/E/1							2	—	C	
	10-20 TB 567							1	L.72	LM	RC16
	10-20 TB 573ND							1	L.72	LM	RC16
	10-20 TB 1227ND							1	L.72	LM	RC16
	10-20 TB 1251A							1	—	—	RC16
28D/15209	AS.4565/1C							10	—	C	
	10-20 TB 1801A							1	—	—	RC18
	10-20 TB 1802A							1	—	—	RC18
28M/9434251	AGS.2008/B/1							6	—	C	
	10-20 TB 2161A/ND							2	—	—	RC18
17175	10-20 TB 5019A/ND							2	—	C	RC18
17081	10-20 TB 1805							2	—	C	RC18
	10-20 TB 2185A/ND							1	—	—	RC18
17176	10-20 TB 5023A/ND							1	—	C	RC18

**TAIL UNIT
FIN AND TAIL BOOM**

Ref. No.	Part No.	Description	No. off	Material Specification	Class of Store or L.M.	Plate No.
	10-20 TB 2186A/ND	MOUNTING , starter unit, Starboard, assembly (Mods. 740 and 7) (For spares use 10-20 TB 5024A/ND)	1	—	—	RC18
17177	10-20 TB 5024A/ND	MOUNTING , starter unit, Starboard, assembly (Spares condition)	1	—	C	RC18
28M/9993192	AGS.2009/C/1	NUT , anchor, 2 BA, access door attachments, etc.				
		Port	102	—	C	
		Starboard	140	—	C	
2278	10-20 TB 423A	RIB , joint, tail boom to fin, Port, assembly	1	—	C	RC10 RC11
	—	Spares for :—				
		BLOCKS , clamp, three pipe, secured to centre outboard mounting, bracket, group	1	—	—	
	10 S 3661	BLOCK , clamp, half, outer	1	LFS.21	LM	RC11
	10 S 3663	BLOCK , clamp, half, inner	1	LFS.21	LM	RC11
28D/9435710	A25/11C	BOLT , 2 BA	2	—	C	
	10 S 3665	BLOCK , clamp, half, three pipe, secured to centre inboard mounting bracket	2	LFS.21	LM	RC11
		Attachments for 10 S 3665, Block (per pair):—				
28D/9140645	A25/10C	Bolt, 2 BA	2	—	C	
	10-20 TB 2099A	BRACKET , mounting, upper, inboard, assembly	1	—	—	RC11
	10-20 TB 2095ND	BRACKET , bare, 18 SWG	1	L.72	LM	RC11
28M/9434252	AGS.2018/B/1	NUT , anchor, 4 BA	2	—	C	
	10-20 TB 2097ND	PLATE , packing, 12 SWG	1	L.72	LM	RC11
	10 TF 1635A	BRACKET , clamp block mounting, centre inboard, assembly	2	—	—	RC11
	10 TF 1637ND	BRACKET , bare, 16 SWG	1	L.72	LM	RC11
28M/9993192	AGS.2009/C/1	NUT , anchor, 2 BA	2	—	C	

**TAIL UNIT
FIN AND TAIL BOOM**

Ref. No.	Part No.	Description	No. off	Material Specification	Class of Store or L.M.	Place No.
	10-20 TF 1627A	BRACKET , clamp block mounting, centre outboard, assembly	1	—	—	RC11
28M/11957	10 TF 1629ND	BRACKET , bare, 18 SWG ...	1	L.72	LM	RC11
	AGS.2007/C/1	NUT , anchor, 2 BA ...	2	—	C	
28M/11957	10 S 4535A	BRACKET , mounting, lower centre, assembly	1	—	—	RC11
	10 S 4533ND	BRACKET , bare, 18 SWG ...	1	L.72	LM	
	AGS.2007/C/1	NUT , anchor, 2 BA ...	2	—	C	
	10-20 TB 339	BRACKET , bottom joint	1	L.53	—	RC11
	—	STRIPS , bonding, at clamp blocks, ".015 thick (Make from Ref. No. 30B/1232) (Mod. 1326)	QR	Zinc	LM	
2279	10-20 TB 425A	RIB , joint, tail boom to fin, Starboard, assembly	1	—	C	RC10 RC11
	—	BLOCKS , clamp, three pipe, secured to centre outboard mounting bracket, group	1	—	—	
28D/9435710	10 S 3661	BLOCK , clamp, half, inner ...	1	LFS.21	LM	RC11
	10 S 3663	BLOCK , clamp, half, outer ...	1	LFS.21	LM	RC11
	A25/11C	BOLT , 2 BA ...	2	—	C	
	10 S 3665	BLOCK , clamp, half, three pipe, secured to centre inboard mounting bracket	2	LFS.21	LM	RC11
	—	Attachments for 10 S 3665, Block (per pair) :—				
28D/12515	A25/10C	Bolt , 2 BA ...	2	—	C	
28M/9434252	10-20 TB 2115A	BRACKET , mounting, upper inboard, assembly	1	—	—	RC11
	10-20 TB 2113ND	BRACKET , bare, 18 SWG ...	1	L.72	LM	RC11
	AGS.2018/B/1	NUT , anchor, 4 BA ...	2	—	C	
	10 TF 1636A	BRACKET , clamp block mounting, centre inboard, assembly	2	—	—	RC11
28M/9993192	10 TF 1638ND	BRACKET , bare, 16 SWG ...	1	L.72	LM	RC11
	AGS.2009/C/1	NUT , anchor, 2 BA ...	2	—	C	
	10 TF 1628A	BRACKET , clamp block mounting, centre outboard, assembly	1	—	—	RC11
28M/11957	10 TF 1630ND	BRACKET , bare, 18 SWG ...	1	L.72	LM	RC11
	AGS.2007/C/1	NUT , anchor, 2 BA ...	2	—	C	
28M/11957	10 S 4535A	BRACKET , mounting, lower centre, assembly	1	—	—	RC11
	10 S 4533ND	BRACKET , bare, 18 SWG ...	1	L.72	LM	RC11
	AGS.2007/C/1	NUT , anchor, 2 BA ...	2	—	C	
	10-20 TB 339	BRACKET , bottom joint	1	L.53	—	RC11
	—	STRIPS , bonding, at clamp blocks, ".015 thick (Make from Ref. No. 30B/1232) (Mod. 1326)	QR	Zinc	LM	
	—	Attachments for 10-20 TB 423A or 10-20 TB 425A, Rib and 10-20 TB 291ND or 10-20 TB 292ND and 10-20 TB 533. Straps :—				
1654	DHS.358/2C	Bolt , 2 BA ...	26	—	C	RC10
2346	DHS.358/2½C	Bolt , 2 BA ...	22	—	C	RC10
1655	DHS.358/3C	Bolt , 2 BA ...	12	—	C	RC10
28M/9403520	A27/CP	Nut , 2 BA ...	60	—	C	
28W/9128924	SP.14/C	Washer ...	4	—	C	
	—	RING , joint, rear, Port, group	1	—	—	
	—	RING , joint, rear, Starboard, group	1	—	—	
2347	DHS.358/3½C	BOLT , 2 BA ...	14	—	C	RC10
3815	DHS.358/4½C	BOLT , 2 BA ...	16	—	C	RC10
2340	DHS.358/4½E	BOLT , ½" BSF ...	4	—	C	RC10

**TAIL UNIT
FIN AND TAIL BOOM**

Ref. No.	Part No.	Description	No. off	Material Specification	Class of Store or L.M	Plate No.
2247	DHS.358/5½E	BOLT, ½" BSF	30	S.96	C	RC10
2341	DHS.358/6E	BOLT, ½" BSF	12	S.96	C	RC10
2253	DHS.358/7E	BOLT, ½" BSF	42	S.96	C	RC10
2342	DHS.358/7½E	BOLT, ½" BSF	10	S.96	C	RC10
2255	DHS.358/8½E	BOLT, ½" BSF	16	S.96	C	RC10
8517	DHS.358/9½E	BOLT, ½" BSF	8	S.96	C	RC10
7887	DHS.358/12E	BOLT, ½" BSF	8	S.96	C	RC10
3786	DHS.358/7½G	BOLT, ⅜" BSF	2	S.96	C	RC10
	DHS.358/8½G	BOLT, ⅜" BSF	4	S.96	—	RC10
2345	DHS.358/9G	BOLT, ⅜" BSF	8	S.96	C	RC10
8521	DHS.358/9½G	BOLT, ⅜" BSF	12	S.96	C	RC10
8228	DHS.358/10G	BOLT, ⅜" BSF	8	S.96	C	RC10
8229	DHS.358/11G	BOLT, ⅜" BSF	8	S.96	C	RC10
9739	DHS.358/12G	BOLT, ⅜" BSF	12	S.96	C	RC10
28M/9403520	A27/CP	NUT, 2 BA	30	—	C	RC10
28M/12928	A27/EP	NUT, ½" BSF	150	—	C	RC10
28M/1006939	A27/GP	NUT, ⅜" BSF	54	—	C	RC10
	10-20 TB 1297	PLATE, reinforcing, top forward (For Spares use 10-20 TB 1749ND)	1	—	—	RC10
14701	10-20 TB 1749ND	PLATE, reinforcing, top forward (Spares condition)	1	DTD.687	C	
11736	10-20 TB 1479A	RING, joint, rear, Port, assembly	1	—	P	RC10
11737	10-20 TB 1480A	RING, joint, rear, Starboard, assembly	1	—	P	RC10
	10-20 TB 1291	RING, joint, rear, L.H. (Mod. 188) (For spares use 10-20 TB 1503ND)	1	—	—	RC10
11120	10-20 TB 1503ND	RING, joint, rear, L.H. (Spares condition)	1	—	C	
	10-20 TB 1292	RING, joint, rear, R.H. (Mod. 188) (For spares use 10-20 TB 1504ND)	1	—	—	RC10
11121	10-20 TB 1504ND	RING, joint, rear, R.H. (Spares condition)	1	—	C	
9740	10-20 TB 1285	STRAP, joint, L.H. (Mod. 188)	2	L.73	C	RC10
9741	10-20 TB 1286	STRAP, joint, R.H. (Mod. 188)	2	L.73	C	RC10
9737	10-20 TB 1293	STRAP, top (Mod. 188)	2	DTD.5050	C	RC10
28W/9419475	SP.15/C	WASHER	30	—	C	
28W/9419405	SP.15/E	WASHER	82	—	C	
28W/9419476	SP.15/G	WASHER	54	—	C	
28W/9419487	SP.16/E	WASHER	68	—	C	
	10-20 TB 1183A/ND	SKIN, inboard, complete with stringers and reinforcements, port, group	1	—	—	RC10
	10-20 TB 367ND	CHANNEL, side, forward, between frames No. 2 and No. 5	1	L.73	—	RC10
	10-20 TB 369ND	CHANNEL, side, aft, between frame No. 5 and fin joint rib	1	L.73	—	RC10
	10-20 TB 349	PLATE, joint, side channels at frame No. 5...	1	L.73	—	RC10
	10-20 TB 285	PLATE, reinforcing, handhole, between frame No. 7 and fin joint rib	1	L.73	—	RC10
10438	10-20 TB 927ND	SKIN, top (For spares use 10-20 TB 1485ND)	1	DTD.687	—	RC10
	10-20 TB 1485ND	SKIN, top (Spares condition)	1	DTD.687	C	
	10-20 TB 931ND	SKIN, bottom (For spares use 10-20 TB 1481ND)	1	DTD.687	—	RC10
10434	10-20 TB 1481ND	SKIN, bottom (Spares condition)	1	DTD.687	C	
	10-20 TB 351ND	STRINGER, lower, between forward edge and fin joint rib	1	—	—	RC10
	10-20 TB 1184A/ND	SKIN, inboard, complete with stringers and reinforcements, Starboard, group	1	—	—	RC10
	10-20 TB 368ND	CHANNEL, side, forward, between frames No. 2 and No. 5	1	L.73	—	RC10

TAIL UNIT
FIN AND TAIL BOOM

Ref. No.	Part No	Description	No of	Material Specification	Class of Store or L.M	Plate No.
	10-20 TB 370ND	CHANNEL , side, aft, between frame No. 5 and fin joint rib	1	L.73	—	RC10
	10-20 TB 350	PLATE , joint, side channels, at frame No. 5	1	L.73	—	RC10
	10-20 TB 286	PLATE , reinforcing, handhole, between frame No. 7 and fin joint rib	1	L.73	—	RC10
	10-20 TB 928ND	SKIN , top (For spares use 10-20 TB 1486ND)	1	DTD.687	—	RC10
10439	10-20 TB 1486ND	SKIN , top (Spares condition)	1	DTD.687	C	
	10-20 TB 932ND	SKIN , bottom (For spares use 10-20 TB 1482ND)	1	DTD.687	—	RC10
10435	10-20 TB 1482ND	SKIN , bottom (Spares condition)	1	DTD.687	C	
	10-20 TB 352ND	STRINGER , lower, between forward edge and fin joint rib	1	—	—	RC10
	10-20 TB 1207A/ND	SKIN , outboard, complete with frames, stringers and reinforcing, Port, assembly (Pre Mod. 7)	1	—	—	RC10
	10-20 TB 2199A/ND	SKIN , outboard, complete with frames, stringers and reinforcing, Port, assembly (Mods. 740 and 7)	1	—	—	RC10
	10-20 TB 365ND	CHANNEL , side, forward, between frames No. 2 and No. 5	1	L.73	—	RC10
	10-20 TB 369ND	CHANNEL , side, aft, between frame No. 5 and fin joint rib	1	L.73	—	RC10
8930	10-20 TB 1143A	FRAME , No. 1, assembly (Pre Mod. 7) ...	1	—	C	RC10
17076	10-20 TB 2165A	FRAME , No. 1, assembly (Mods. 740 and 7) Spares for :—	1	—	C	RC10
	10-20 TB 1785A	BRACKET , attachment for panel coded "UF," forward of frame No. 1, assembly (Mods. 740 and 7)	2	—	—	RC19
	10-20 TB 1787ND	BRACKET , bare, 18 SWG	1	L.72	LM	RC19
28M/11957	AGS.2007/C/1	NUT , anchor, 2 BA	1	—	C	
	10-20 TB 747A	BRACKET , clamp block mounting upper, assembly	1	—	—	RC19
	10-20 TB 749ND	BRACKET , bare, 18 SWG	1	L.72	LM	RC19
28M/13307	AGS.2018/B/1	NUT , anchor, 4 BA	2	—	C	
	10-20 TB 897A	BRACKET , clamp block mounting, lower inboard, assembly	1	—	—	RC19
	10-20 TB 899ND	BRACKET , bare, 20 SWG	1	L.72	LM	RC19
28M/9144673	AGS.2019/C/1	NUT , anchor, 2 BA	2	—	C	
	10-20 TB 1383A	BRACKET , mounting, lower outboard, assembly	1	—	—	RC19
	10-20 TB 1381ND	BRACKET , bare, 18 SWG	1	L.72	LM	RC19
28M/12153	AGS.2007/B/1	NUT , anchor, 4 BA	1	—	C	
	10-20 TB 1147A	FRAME , No. 2, assembly (Pre Mod. 7) (For Spares use 10-20 TB 1513A/ND)	1	—	—	RC19
11128	10-20 TB 1513A/ND	FRAME , No. 2, assembly (Pre Mod. 7) (Spares condition) Spares for :—	1	—	C	
	10-20 TB 859A	BRACKET , mounting, upper inboard, assembly	1	—	—	RC19
	10-20 TB 857ND	BRACKET , bare, 18 SWG	1	L.72	LM	RC19
28M/13307	AGS.2018/B/1	NUT , anchor, 4 BA	2	—	C	
	10-20 TB 897A	BRACKET , clamp block mounting, lower inboard, assembly	1	—	—	RC19
	10-20 TB 899ND	BRACKET , bare, 20 SWG	1	L.72	LM	RC19
28M/9144673	AGS.2019/C/1	NUT , anchor, 2 BA	2	—	C	

**TAIL UNIT
FIN AND TAIL BOOM**

Ref. No.	Part No.	Description	No. off	Material Specification	Class of Score or LM	Plate No.
	10-20 TB 1617A	FRAME, No. 2, assembly (Mod. 7) (For spares use 10-20 TB 2125A/ND)	1	—	—	RC10
15108	10-20 TB 2125A/ND	FRAME, No. 2, assembly (Mod. 7) (Spares condition)	1	—	C	
	10-20 TB 859A	BRACKET, mounting, upper centre, assembly	1	—	—	RC19
	10-20 TB 857ND	BRACKET, bare, 18 SWG	1	L.72	LM	RC19
28M/9434252	AGS.2018/B/1	NUT, anchor, 4 BA	2	—	C	
	10-20 TB 897A	BRACKET, clamp block mounting, lower inboard, assembly	1	—	—	RC19
	10-20 TB 899ND	BRACKET, bare, 20 SWG	1	L.72	LM	RC19
28M/9144673	AGS.2019/C/1	NUT, anchor, 2 BA	2	—	C	
	10-20 TB 1153A	FRAME, No. 3, assembly (Pre Mod. 7) (For Spares use 10-20 TB 1505A/ND)	1	—	—	RC10
11345	10-20 TB 1505A/ND	FRAME, No. 3, assembly (Pre Mod. 7) (Spares condition)	1	—	C	
	10-20 TB 1619A	FRAME, No. 3, assembly (Mod. 7) (For spares use 10-20 TB 2129A/ND)	1	—	—	RC10
15109	10-20 TB 2129A/ND	FRAME, No. 3, assembly (Mod. 7) (Spares condition)	1	—	C	
	10-20 TB 879A	BRACKET, mounting, upper, assembly ...	1	—	—	RC19
	10-20 TB 877ND	BRACKET, bare, 18 SWG	1	L.72	LM	RC19
28M/9434252	AGS.2018/B/1	NUT, anchor, 4 BA	2	—	C	
	10-20 TB 897A	BRACKET, clamp block mounting, lower inboard, assembly	1	—	—	RC19
	10-20 TB 899ND	BRACKET, bare, 20 SWG	1	L.72	LM	RC19
28M/9144673	AGS.2019/C/1	NUT, anchor, 2 BA	2	—	C	
	10-20 TB 1161A	FRAME, No. 4, assembly (For Spares use 10-20 TB 1529A/ND)	1	—	—	RC10
11134	10-20 TB 1529A/ND	FRAME, No. 4, assembly (Spares condition)	1	—	C	
	10-20 TB 867A	BRACKET, mounting, upper inboard, assembly	1	—	—	RC19
	10-20 TB 865ND	BRACKET, bare, 18 SWG	1	L.72	LM	RC19
28M/9434252	AGS.2018/B/1	NUT, anchor, 4 BA	2	—	C	
	10-20 TB 893A	BRACKET, clamp block mounting, lower outboard, assembly	1	—	—	RC19
	10-20 TB 895ND	BRACKET, bare, 20 SWG	1	L.72	LM	RC19
28M/9144673	AGS.2019/C/1	NUT, anchor, 2 BA	2	—	C	
	10-20 TB 1167A	FRAME, No. 5, assembly (For Spares use 10-20 TB 1537A/ND)	1	—	—	RC10
11136	10-20 TB 1537A/ND	FRAME, No. 5, assembly (Spares condition)	1	—	C	
	10-20 TB 1057	BRACKET, mounting, lower inboard, saddle clip	1	L.72	LM	RC19
	10-20 TB 871A	BRACKET, mounting, upper inboard, assembly	1	—	—	RC19
	10-20 TB 869ND	BRACKET, bare, 18 SWG	1	L.72	LM	RC19
28M/9434252	AGS.2018/B/1	NUT, anchor, 4 BA	2	—	C	
	10-20 TB 905A	BRACKET, clamp block mounting, lower outboard, assembly	1	—	—	RC19
	10-20 TB 919ND	BLOCK, packing, 0"17 thick	1	LFS.21	LM	RC19

TAIL UNIT
FIN AND TAIL BOOM

Ref. No.	Part No.	Description	No. off	Material Specification	Class of Store or L.M	Place No.
28M/9144673	10-20 TB 1071ND	BRACKET , bare, 20 SWG	1	L.72	LM	RC19
	AGS.2019/C/1	NUT , anchor, 2 BA	2	—	C	
11130	10-20 TB 1073ND	PLATE , backing, 20 SWG	1	L.72	LM	RC19
	10-20 TB 1173A	FRAME , No. 6, assembly (For Spares use 10-20 TB 1541A/ND)	1	—	—	RC10
28M/9434252	10-20 TB 1051ND	BRACKET , bare, 18 SWG	1	L.72	LM	RC19
	AGS.2018/B/1	NUT , anchor, 4 BA	2	—	C	
28M/9144673	10-20 TB 909A	BRACKET , clamp block mounting, lower	1	—	—	RC19
	10-20 TB 923ND	BLOCK , packing, 0"3 thick	1	LFS.21	LM	RC19
28M/9144673	10-20 TB 1095ND	BRACKET , bare, 20 SWG	1	L.72	LM	RC19
	AGS.2019/C/1	NUT , anchor, 2 BA	2	—	C	
2276	10-20 TB 1097ND	PLATE , backing, 22 SWG	1	L.72	LM	RC19
	10-20 TB 417A	FRAME , No. 7, assembly	1	—	C	RC10
28M/9434252	10-20 TB 2093A	Spares for :— BRACKET , mounting, upper inboard, assembly	1	—	—	RC19
	10-20 TB 2091ND	BRACKET , bare, 18 SWG	1	L.72	LM	RC19
28M/9434252	AGS.2018/B/1	NUT , anchor, 4 BA	2	—	C	
	10-20 TB 913A	BRACKET , clamp block mounting, lower centre, assembly	1	—	—	RC19
28M/9435067	10-20 TB 915ND	BRACKET , bare, 20 SWG	1	L.72	LM	RC19
	AGS.2008/C/1	NUT , anchor, 2 BA	2	—	C	
10440	19-20 TB 347ND	PLATE , doubling, forward and aft at telebrief plug handhole, between frames No. 3 and No. 4	1	L.72	—	RC10
	10-20 TB 349	PLATE , joint, side channels, at frame No. 5	1	L.73	—	RC10
10436	19-20 TB 285	PLATE , reinforcing, handhole, between frame No. 7 and fin joint rib	1	L.73	—	RC10
	10-20 TB 289	PLATE , reinforcing, upper and lower at telebrief plug handhole, between frames No. 3 and No. 4	2	L.73	—	RC10
10440	10-20 TB 925ND	SKIN , top (For spares use 10-20 TB 1487ND)	1	DTD.687	—	RC10
	10-20 TB 1487ND	SKIN , top (Spares condition)	1	—	C	
10436	10-20 TB 929ND	SKIN , bottom (For spares use 10-20 TB 1483ND)	1	DTD.746	—	RC10
	10-20 TB 1483ND	SKIN , bottom (Spares condition)	1	—	C	
8231	10-20 TB 451ND	STRINGER , lower, between joint ring and fin joint rib	1	—	—	RC10
	10-20 TB 1209A/ND	SKIN , outboard, complete with frames, stringers and reinforcements, Starboard, assembly	1	—	—	RC10
8231	10-20 TB 366ND	CHANNEL , side, forward, between frames No. 2 and No. 5	1	L.73	—	RC10
	10-20 TB 370ND	CHANNEL , side, aft, between frame No. 5 and fin joint rib	1	L.73	—	RC10
28M/9434252	10-20 TB 1145A	FRAME , No. 1, assembly	1	—	C	RC10
	10-20 TB 747A	Spares for :— BRACKET , clamp block mounting, upper, assembly	1	—	—	RC19
28M/9434252	10-20 TB 749ND	BRACKET , bare, 18 SWG	1	L.72	LM	RC19
	AGS.2018/B/1	NUT , anchor, 4 BA	2	—	C	
	10-20 TB 898A	BRACKET , clamp block mounting, lower inboard, assembly	1	—	—	RC19

TAIL UNIT
FIN AND TAIL BOOM

Ref. No.	Part No.	Description	No. of	Material Specification	Class of Store or L.M.	Plate No.
28M/9144673	10-20 TB 900ND	BRACKET , bare, 20 SWG	1	L.72	LM	RC19
	AGS.2019/C/1	NUT , anchor, 2 BA	2	—	C	
	10-20 TB 1383A	BRACKET , mounting, lower outboard, assembly	1	—	—	RC19
28M/12153	10-20 TB 1381ND	BRACKET , bare, 18 SWG	1	L.72	LM	RC19
	AGS.2007/B/1	NUT , anchor, 4 BA	1	—	C	
	10-20 TB 1149A	FRAME , No. 2, assembly (For spares use 10-20 TB 1515A/ND)	1	—	—	RC10
11129	10-20 TB 1515A/ND	FRAME , No. 2, assembly (Spares condition) Spares for :—	1	—	C	
	10-20 TB 898A	BRACKET , clamp block mounting lower inboard, assembly	1	—	—	RC19
28M/9144673	10-20 TB 900ND	BRACKET , bare, 20 SWG	1	L.72	LM	RC19
	AGS.2019/C/1	NUT , anchor, 2 BA	2	—	C	
	10-20 TB 1155A	FRAME , No. 3, assembly (For spares use 10-20 TB 1507A/ND)	1	—	—	RC10
11346	10-20 TB 1507A/ND	FRAME , No. 3, assembly (Spares condition) Spares for :—	1	—	C	
	10-20 TB 901A	BRACKET , clamp block mounting, lower inboard, assembly	1	—	—	RC19
28M/9144673	10-20 TB 903ND	BRACKET , bare, 18 SWG	1	L.72	LM	RC19
	AGS.2019/C/1	NUT , anchor, 2 BA	2	—	C	
	10-20 TB 1163A	FRAME No. 4, assembly (For spares use 10-20 TB 1531A/ND)	1	—	—	RC10
11135	10-20 TB 1531A/ND	FRAME , No. 4, assembly (Spares condition) Spares for :—	1	—	C	
	10-20 TB 847A	BRACKET , mounting, upper centre, assembly	1	—	—	RC19
28M/9434252	10-20 TB 845ND	BRACKET , bare, 18 SWG	1	L.72	LM	RC19
	AGS.2018/B/1	NUT , anchor, 4 BA	2	—	C	
	10-20 TB 893A	BRACKET , clamp block mounting lower outboard, assembly	1	—	—	RC19
28M/9144673	10-20 TB 895ND	BRACKET , bare, 20 SWG	1	L.72	LM	RC19
	AGS.2019/C/1	NUT , anchor, 2 BA	2	—	C	
	10-20 TB 1169A	FRAME , No. 5, assembly (For spares use 10-20 TB 1539A/ND)	1	—	—	RC10
11137	10-20 TB 1539A/ND	FRAME , No. 5, assembly (Spares condition) Spares for :—	1	—	C	
	10-20 TB 851A	BRACKET , mounting, upper centre, assembly	1	—	—	RC19
28M/9434252	10-20 TB 849ND	BRACKET , bare, 18 SWG	1	L.72	LM	RC19
	AGS.2018/B/1	NUT , anchor, 4 BA	2	—	C	
	10-20 TB 1175A	FRAME , No. 6, assembly (For spares use 10-20 TB 1543A/ND)	1	—	—	RC10
11131	10-20 TB 1543A/ND	FRAME , No. 6, assembly (Spares condition) Spares for :—	1	—	C	
	10-20 TB 855A	BRACKET , mounting, upper centre, assembly	1	—	—	RC19

**TAIL UNIT
FIN AND TAIL BOOM**

Ref. No.	Part No.	Description	No. off						Material Specification	Class of Store or L.M.	Place No.
			1	2	3	4	5	6			
28M/9434252	10-20 TB 853ND	BRACKET , bare, 18 SWG						1	L.72	LM	RC19
	AGS.2018/B/1	NUT , anchor, 4 BA						1	—	C	
	10-20 TB 909A	BRACKET , clamp block mounting, lower centre, assembly						1	—	—	RC19
28M/9144673	10-20 TB 923ND	BLOCK , packing, 0"3 thick						1	LFS.21	LM	RC19
	10-20 TB 1095ND	BRACKET , bare, 20 SWG						1	L.72	LM	RC19
	AGS.2019/C/1	NUT , anchor, 2 BA						2	—	C	
	10-20 TB 1097ND	PLATE , backing, 22 SWG						1	L.72	LM	RC19
	2277 10-20 TB 419A	FRAME , No. 7, assembly Spares for:—						1	—	C	RC10
	10-20 TB 2109A	BRACKET , mounting, upper, inboard assembly						1	—	—	RC19
28M/9434252	10-20 TB 2107ND	BRACKET , bare, 18 SWG						1	L.72	LM	RC19
	AGS.2018/B/1	NUT , anchor, 4 BA						2	—	C	
	10-20 TB 913A	BRACKET , clamp block mounting lower centre, assembly						1	—	—	RC19
28M/9435067	10-20 TB 915ND	BRACKET , bare, 18 SWG						1	L.72	LM	RC19
	AGS.2008/C/1	NUT , anchor, 2 BA						2	—	C	
	10-20 TB 347ND	PLATE , doubling, forward and aft, at telebrief plug handhole, between frames No. 3 and No. 4						2	L.72	—	RC10
	10-20 TB 350	PLATE , joint, side channels at frame No. 5...						1	L.73	—	RC10
	10-20 TB 286	PLATE , reinforcing, handhole, between frame No. 7 and fin joint rib						1	L.72	—	RC10
	10-20 TB 289	PLATE , reinforcing, upper and lower, at telebrief plug handhole between frames No. 3 and No. 4						2	L.73	—	RC10
10441	10-20 TB 926ND	SKIN , top (For spares use 10-20 TB 1488ND)						1	DTD.687	—	RC10
	10-20 TB 1488ND	SKIN , top (Spares condition)						1	—	C	
14037	10-20 TB 930ND	SKIN , bottom (For spares use 10-20 TB 1484ND)						1	DTD.746	—	RC10
	10-20 TB 1484ND	SKIN , bottom (Spares condition)						1	—	C	
	10-20 TB 453ND	STRINGER , lower between joint ring and fin joint rib						1	—	—	RC10
	10-20 WC 26827A	SPIGOT , top, centre, tail-boom jiggling Attachments for 10-20 WC 26827A, Spigot:—						1	—	—	RC19
2339	DHS.358/5C	Bolt, 2 BA						4	—	C	RC19
	28M/10288	Nut, 2 BA						4	—	C	
	10-20 WC 26829A	SPIGOT , top, aft, tail-boom jiggling Attachments for 10-20 WC 26829A, Spigot:—						1	—	—	RC19
1655	DHS.358/3C	Bolt, 2 BA						4	—	C	RC19
	28M/10288	Nut, 2 BA						4	—	C	
	10-20 WC 26547A	SPIGOT , centre, inboard, tail-boom jiggling						1	—	—	RC19
	10-20 WC 26549A	SPIGOT , aft, inboard, tail-boom jiggling Attachments for 10-20 WC 26547A or 10-20 WC 26549A, Spigot:—						1	—	—	RC19
28D/8308	AS.1242/3C	Bolt, 2 BA						4	—	C	
	28M/10288	Nut, 2 BA						4	—	C	
8226	10-20 TB 1221	STRAP , bottom, aft, at rear joint ring						1	—	C	RC10
	10-20 TB 291ND	STRAP , joint, joggled, around tail boom to fin joint rib, Port, 14 SWG						1	L.73	—	RC10
	10-20 TB 292ND	STRAP , joint, joggled, around tail boom to fin joint rib, Starboard, 14 SWG						1	L.73	—	RC10

**TAIL UNIT
FIN AND TAIL BOOM**

Ref. No.	Part No.	Description	No. off	Material Specification	Class of Store or L.M	Plate No.
	10-20 TB 533	STRAP , joint, tail boom to fin, top ... (Attachments for 10-20 TB 291 ND, 10-20 TB 292ND and 10-20 TB 533, Straps, see Attachments for 10-20 TB 423A or 10-20 TB 425A, Rib)	1	DTD.746	—	RC10
	10-20 TB 535	STRAP , joint, top, located between frame No. 7 and tail boom to fin joint strap, 14 SWG Attachments for 10-20 TB 535, Strap :—	1	DTD.746	—	RC10
1655	DHS.358/3C	Bolt, 2 BA	4	—	C	RC10
28M/9403520	A27/CP	Nut, 2 BA	4	—	C	RC10
	10-20 TB 707ND	Plate, packing, 24 SWG	1	L.72	LM	RC10
28W/9128924	SP.14/C	Washer	4	—	C	RC10
		Attachments for 10-20 TB 1301A, 10-20 TB 1699A or 10-20 TB 1303A, Tail Boom :— At Stub boom :—				
9493	DHS.365/9JJ	Bolt, 1/2" BSF	32	—	C	RC10
		OR				
9492	10-20 TB 829	Bolt, 1/2" BSF (See Repair Section PA)	34	—	C	RC10
28M/1011473	A27/JP	Nut, 1/2" BSF	32	—	C	RC10
28M/1011477	A27/NP	Nut, 1/2" BSF	34	—	C	RC10
9621	10-20 TB 1339ND	Washer, for 3/8" BSF bolts	32	—	C	RC10
9620	10-20 TB 1337ND	Washer, for 3/8" BSF bolts	34	—	C	RC10
28W/1007698	SP.14/J	Washer	32	—	C	RC10
28W/1011085	SP.11/N	Washer	34	—	C	RC10

RC.1

SEE TEXT FOR SPARES CONDITION
OF ITEMS MARKED THUS: * ✱

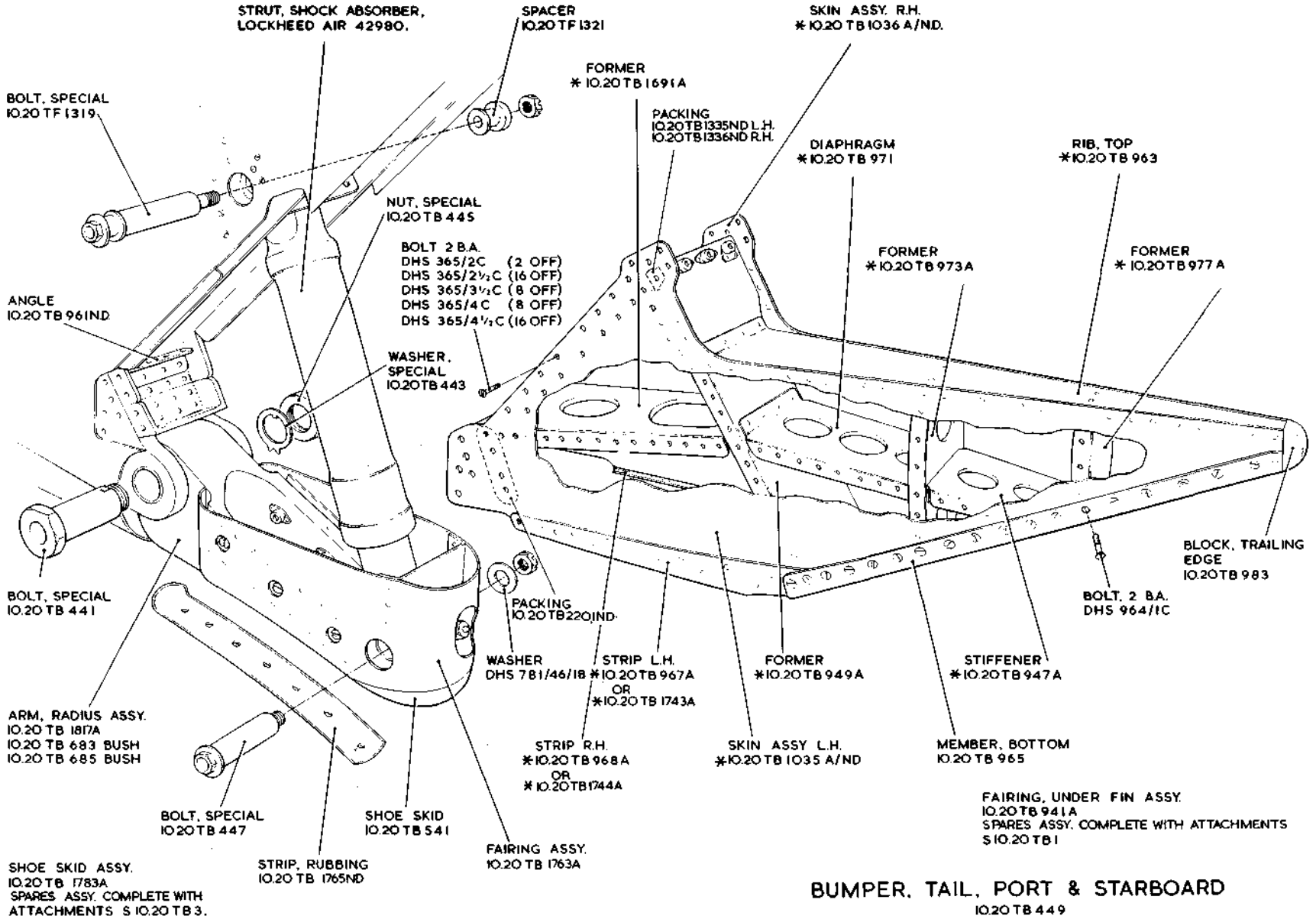

**TAIL UNIT
FIN AND TAIL BOOM**

RESTRICTED

BUMPER, TAIL, PORT & STARBOARD
IO.20 TB 449

See Vixen Mk. 1

RESTRICTED

Plate RC.1

RC.1
DL-32

RC.1

SEE TEXT FOR SPARES CONDITION
OF ITEMS MARKED THUS— *

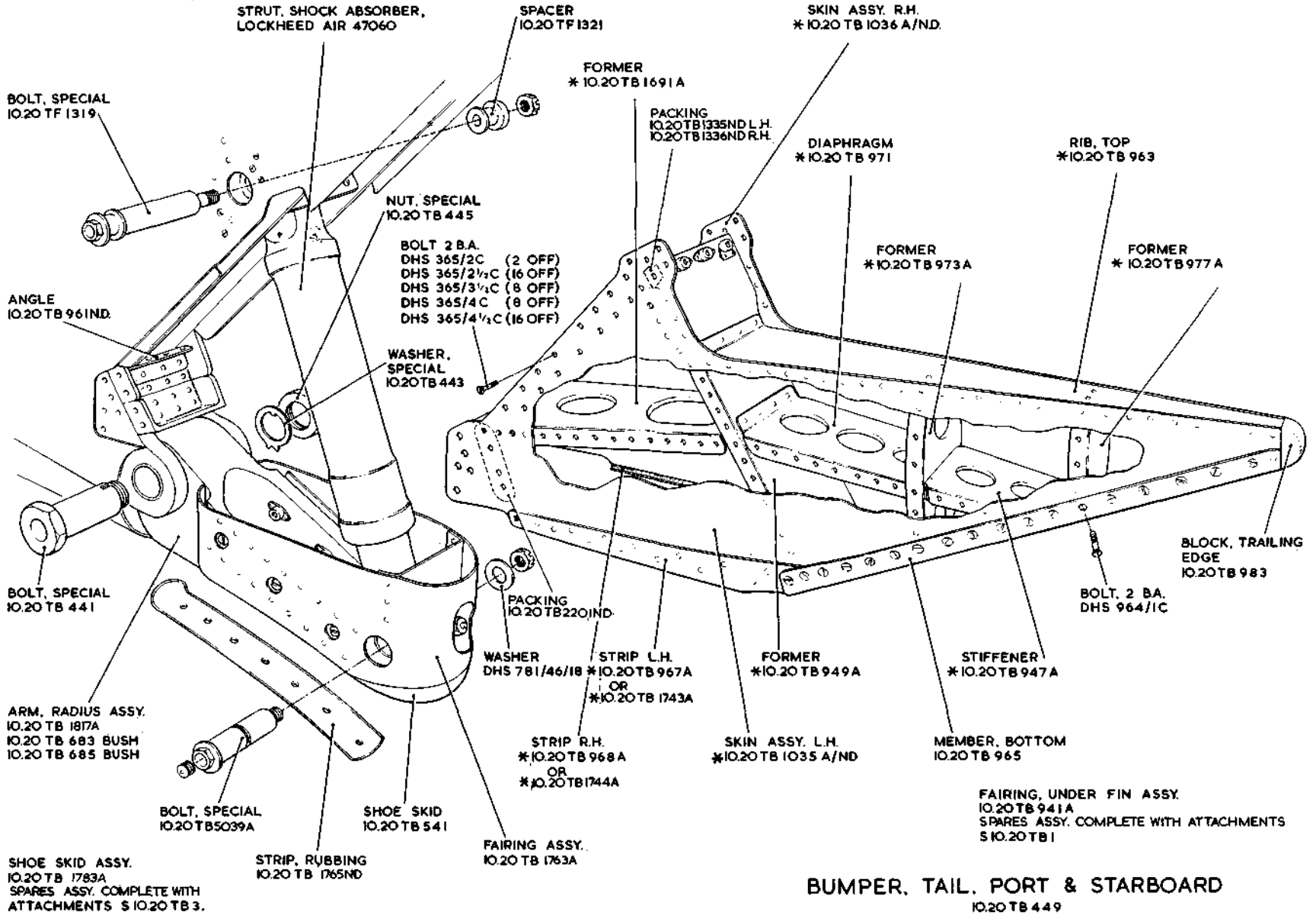

**TAIL UNIT
FIN AND TAIL BOOM**

RESTRICTED

BUMPER, TAIL, PORT & STARBOARD

IO.20 TB 449

See Vixen Mk. 1

RESTRICTED

Plate RC1

RC.1
[Also]

SEE TEXT FOR SPARES CONDITION OF ITEMS MARKED THUS: *

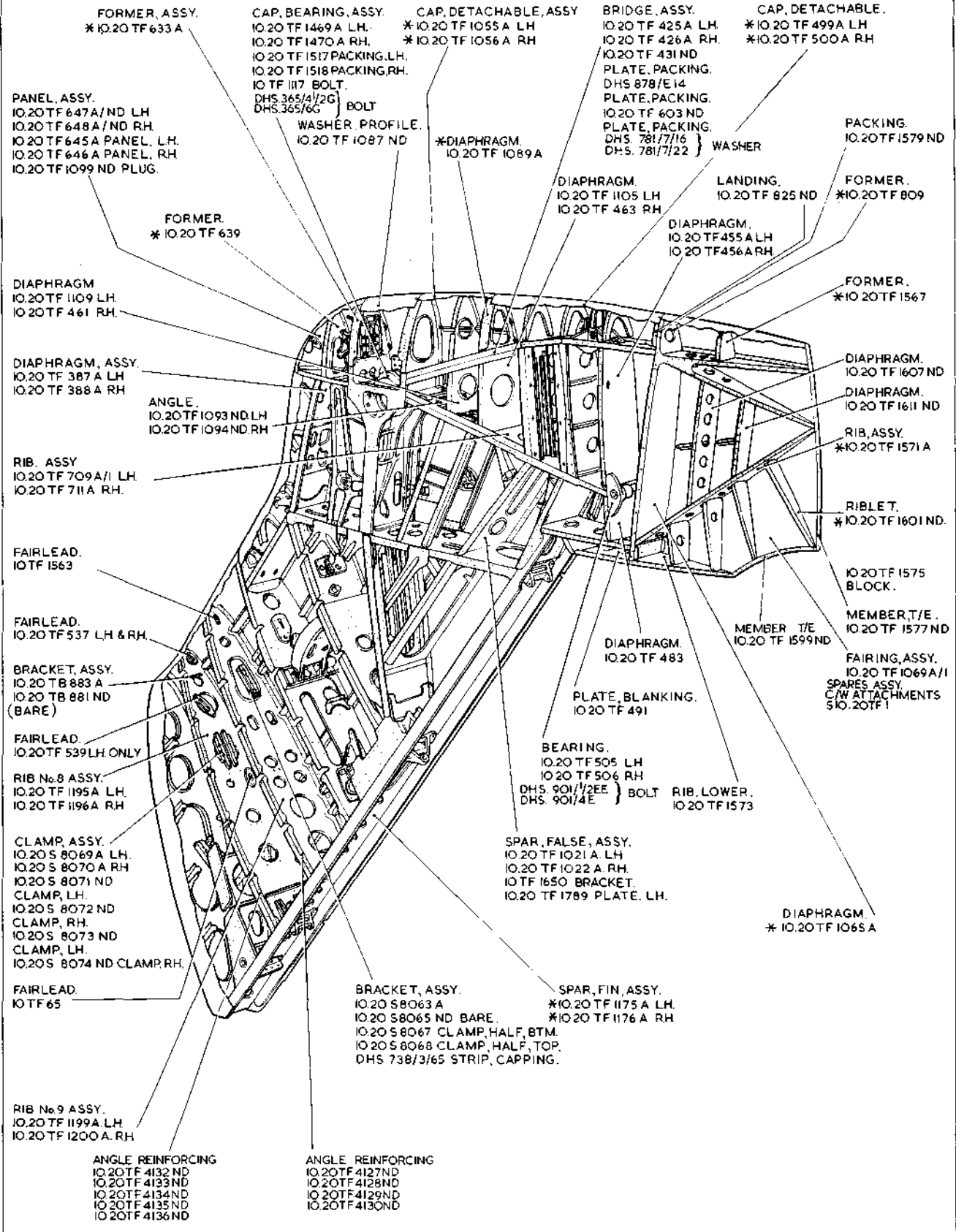

RC.3

TAIL UNIT

RC.3

FIN AND TAIL BOOM

[AL 52]

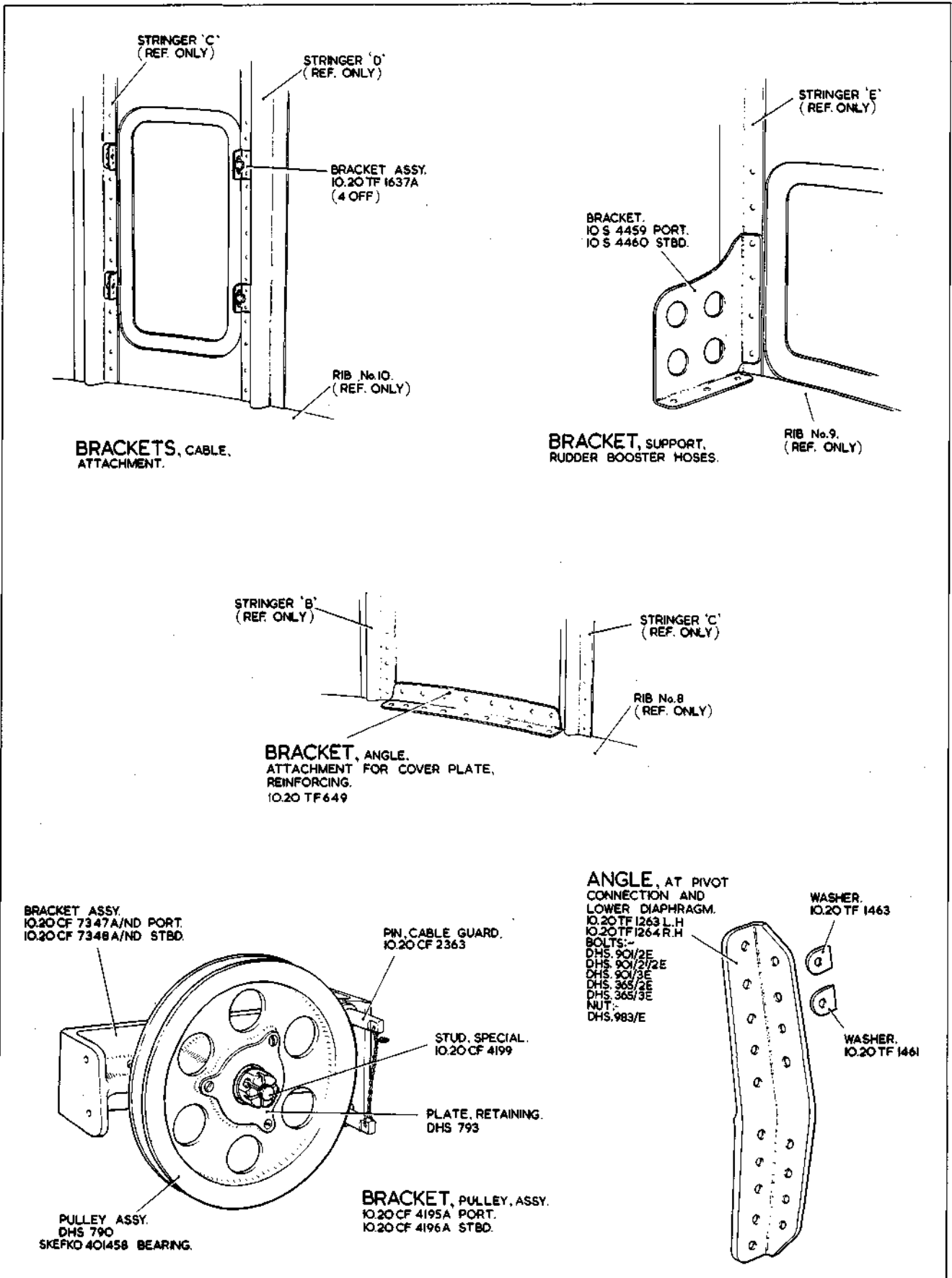

RC.4

TAIL UNIT

RC.4
[AL.39]

FIN AND TAIL BOOM

SEE TEXT FOR SPARES CONDITION
OF ITEMS MARKED THUS: - *

COVER, PANEL, L/E. ASSY.
DRG. IO.20 TF 1365

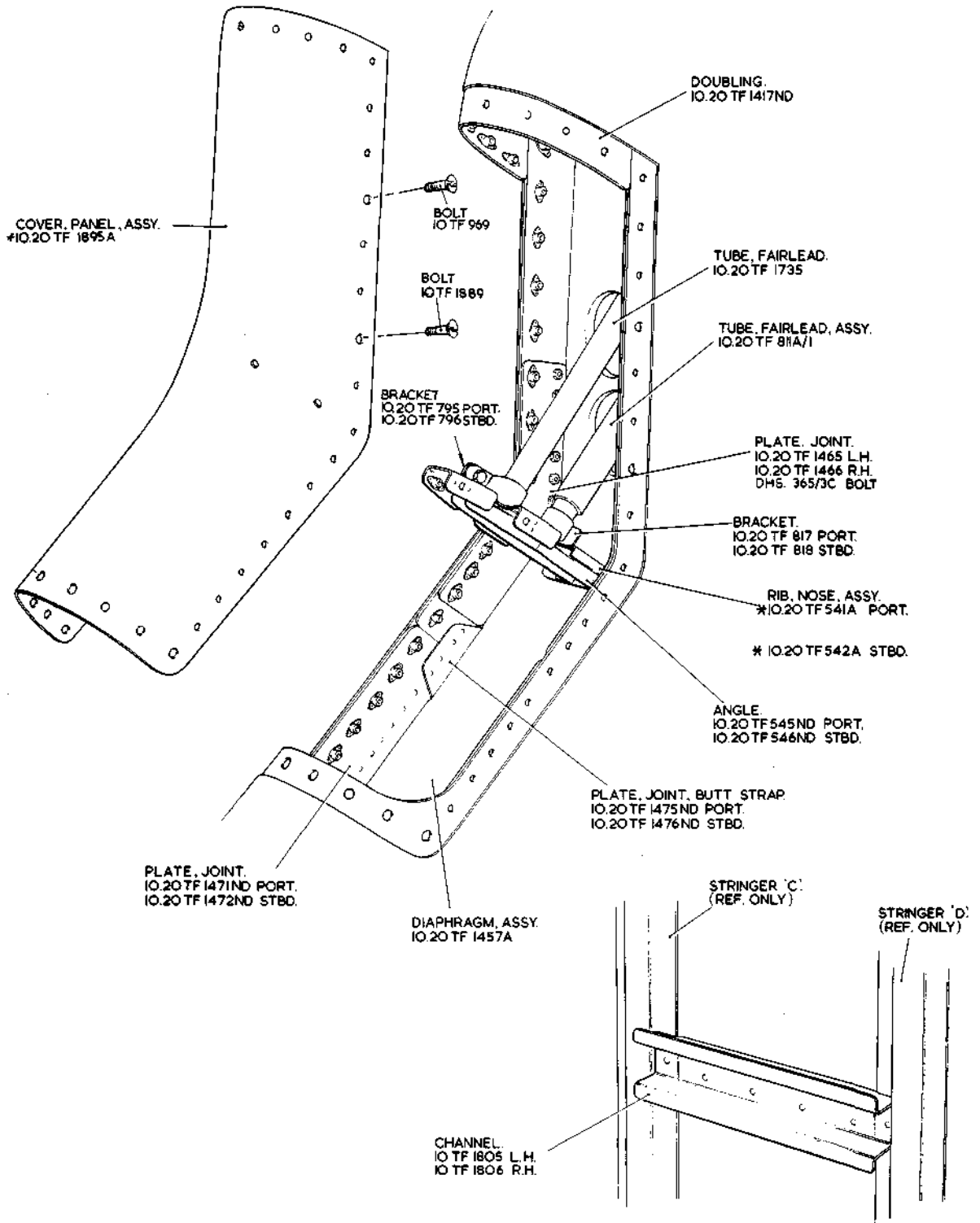

RC.5

TAIL UNIT

RC.5
[A.L. 39]

FIN AND TAIL BOOM

SEE TEXT FOR SPARES CONDITION
OF ITEMS MARKED THUS: *

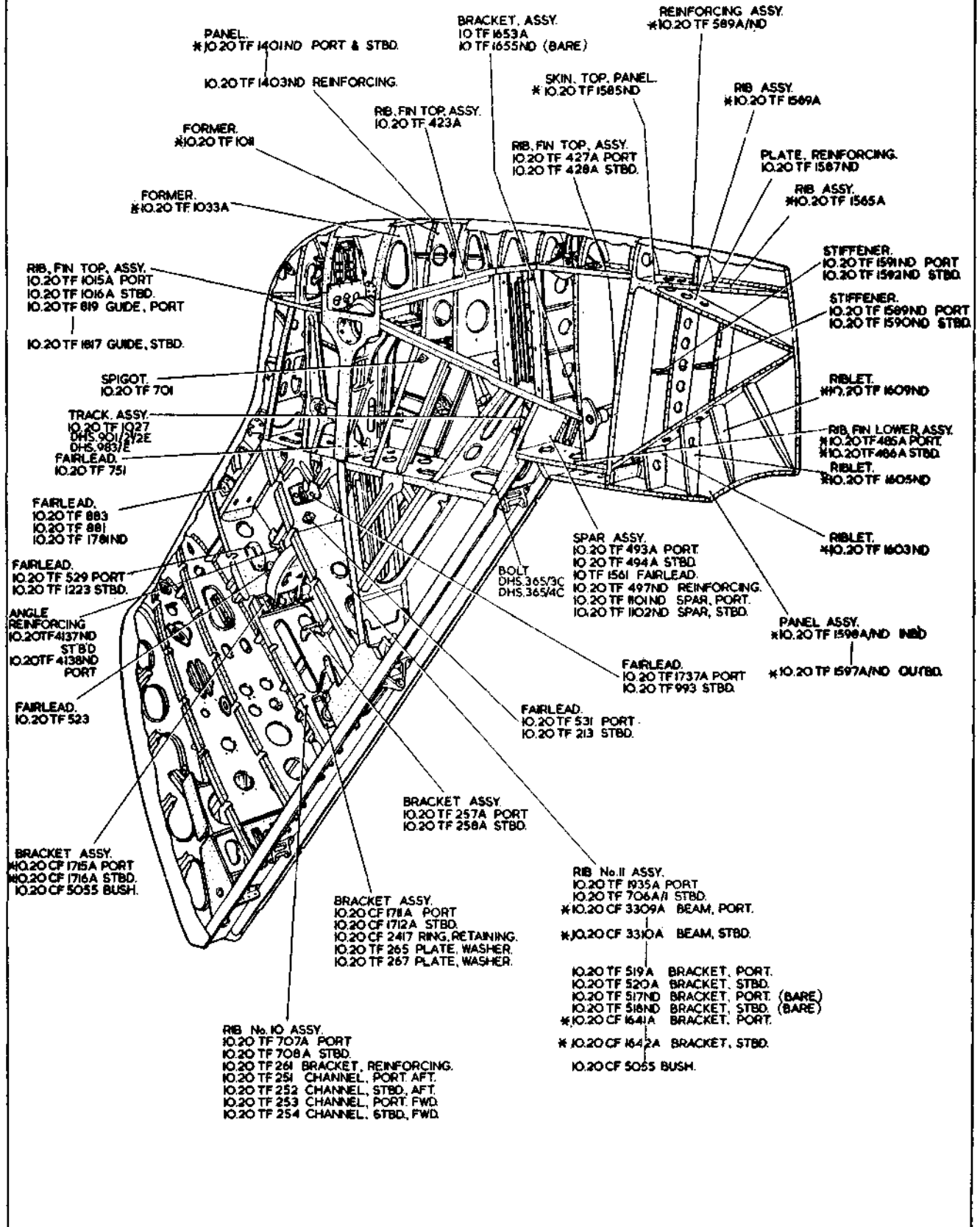

RC.7

TAIL UNIT FIN AND TAIL BOOM

RC.7
(AL.00)

RC.8

TAIL UNIT FIN AND TAIL BOOM

RESTRICTED

SEE TEXT FOR SPARES CONDITION
OF ITEMS MARKED THUS: *

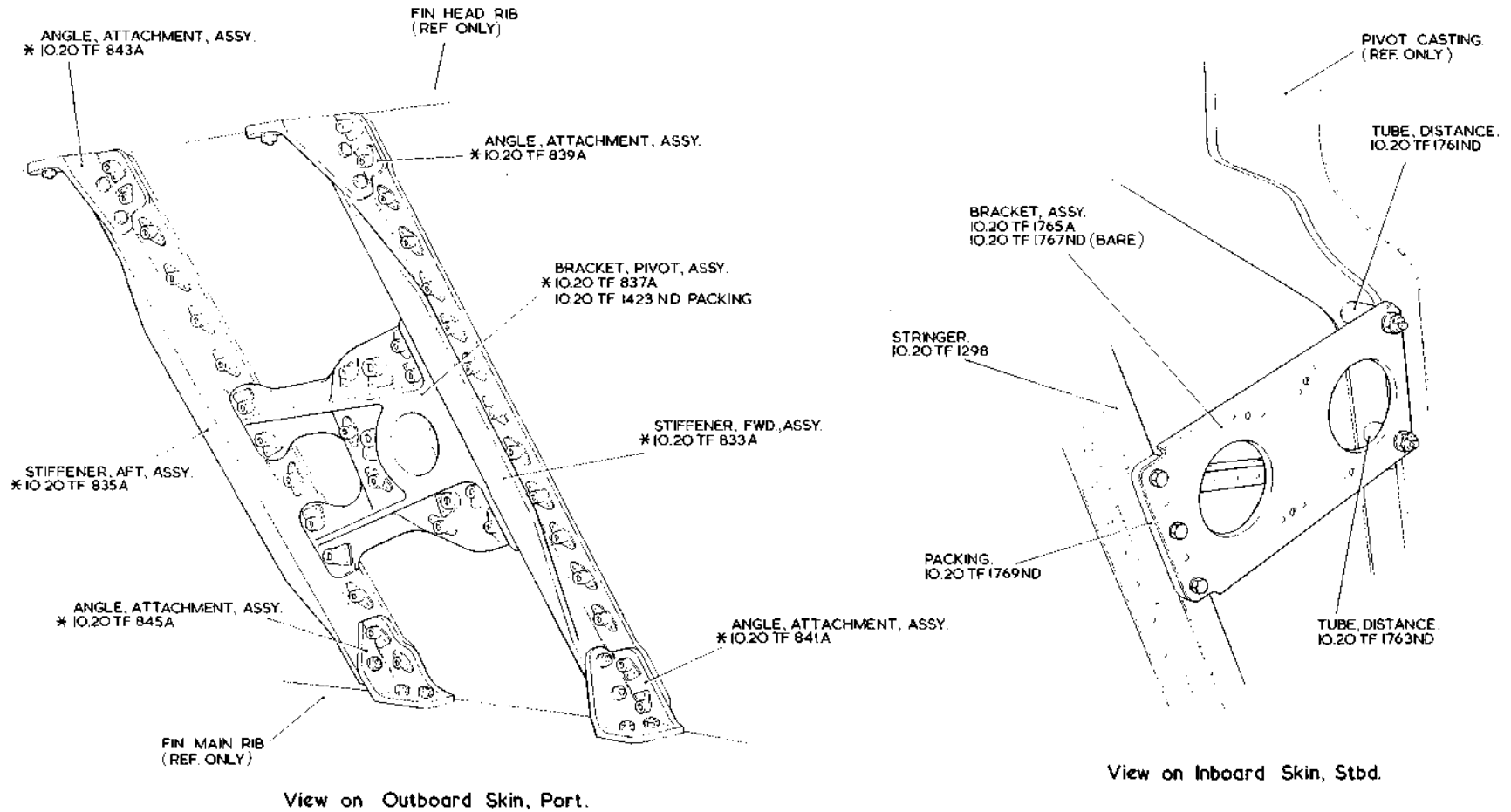

See Vixen Mk. 1

RESTRICTED

Place RC8

RC.8
[AL36]

RC.9

TAIL UNIT FIN AND TAIL BOOM

RESTRICTED

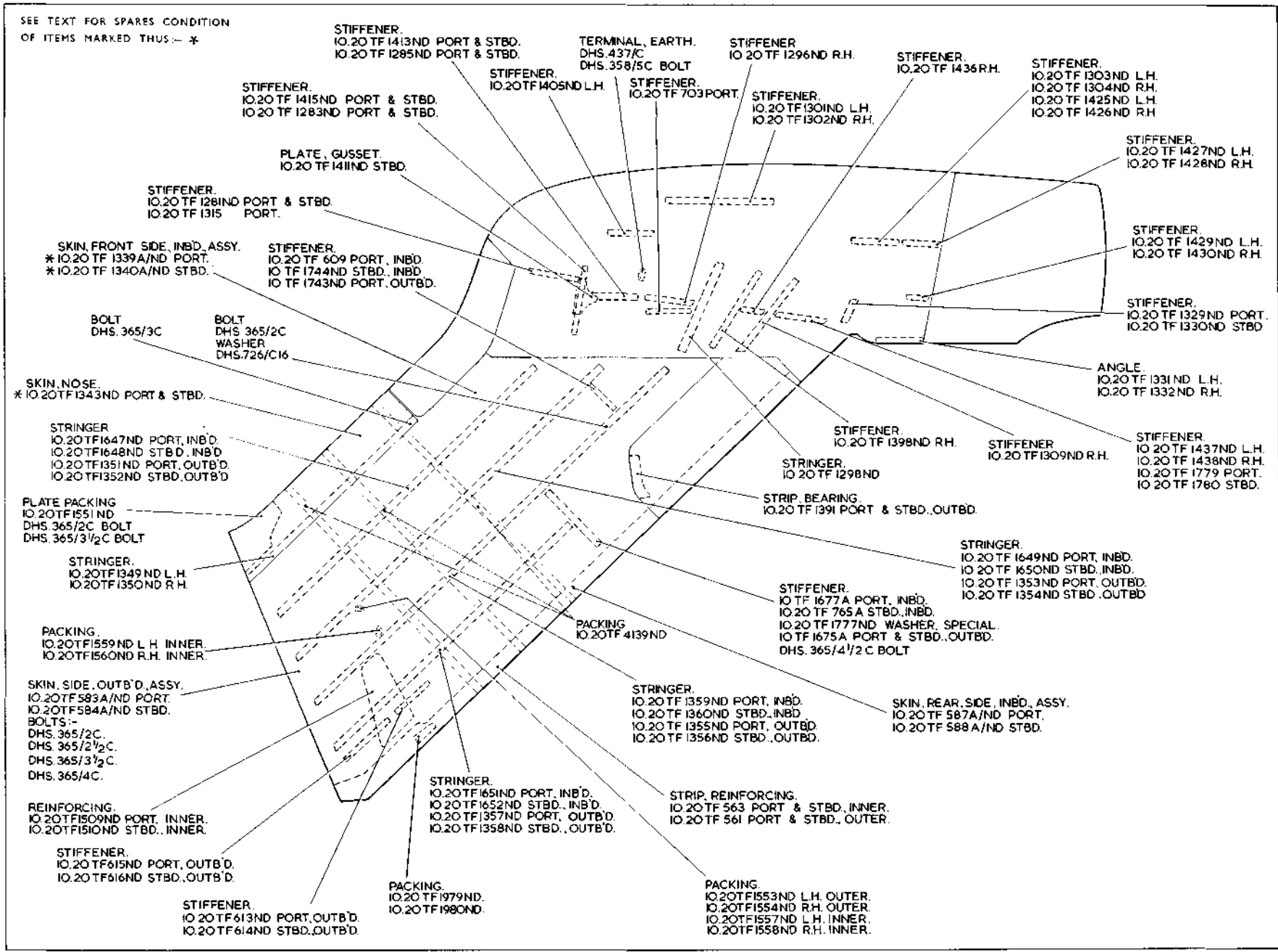

RC.9
[ALL 55]

Sea Vixen Mk. 1

RESTRICTED

Place RC9

RC.10

FIN AND TAIL BOOM

TAIL UNIT

RESTRICTED

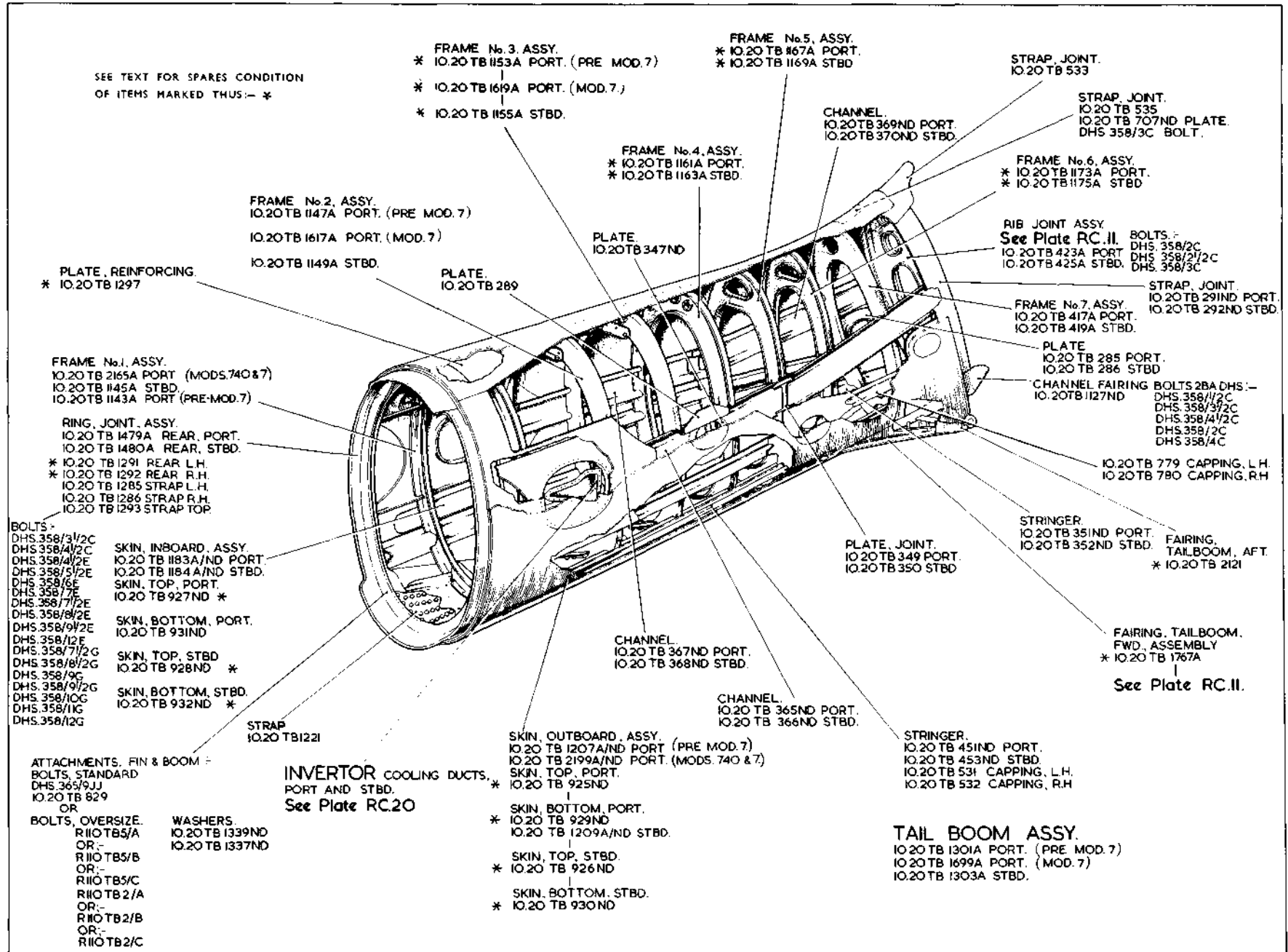

See Vixen Mk. 1

RESTRICTED

Plate RC.10

RC.10
 [AL31]

SEE TEXT FOR SPARES CONDITION
OF ITEMS MARKED THUS: - *

RC.11

FIN AND TAIL BOOM

TAIL UNIT

RESTRICTED

RC.11

7AL391

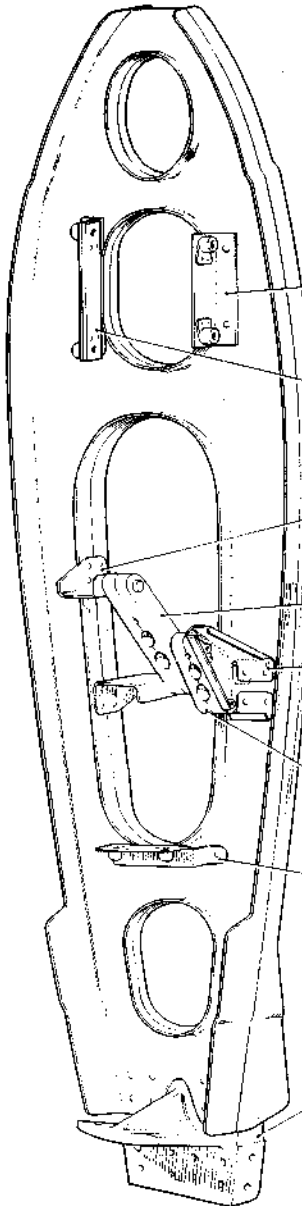

BRACKET, ASSY.
IO.20 TB 2115A (STBD. ONLY)
IO.20 TB 2113ND (BARE)

BRACKET, ASSY.
IO.20 TB 2099A (PORT ONLY)
IO.20 TB 2095ND (BARE)
IO.20 TB 2097ND PLATE, PACKING.

BRACKET, ASSY.
IO TF 1635A PORT.
IO TF 1637ND (BARE)
IO TF 1636A STBD.
IO TF 1638ND (BARE)

BLOCK, CLAMP.
IOS 3665

BRACKET, ASSY.
IO TF 1627A PORT.
IO TF 1629ND (BARE)
IO TF 1628A STBD.
IO TF 1630ND (BARE)

BLOCK, CLAMP.
IOS 3661 INNER.
IOS 3663 OUTER.

BRACKET, ASSY.
IOS 4535A
IOS 4533ND (BARE)

BRACKET, BOTTOM, JOINT.
IO.20 TB 339

RIB, JOINT, ASSY.
IO.20 TB 423A PORT.
IO.20 TB 425A STBD.

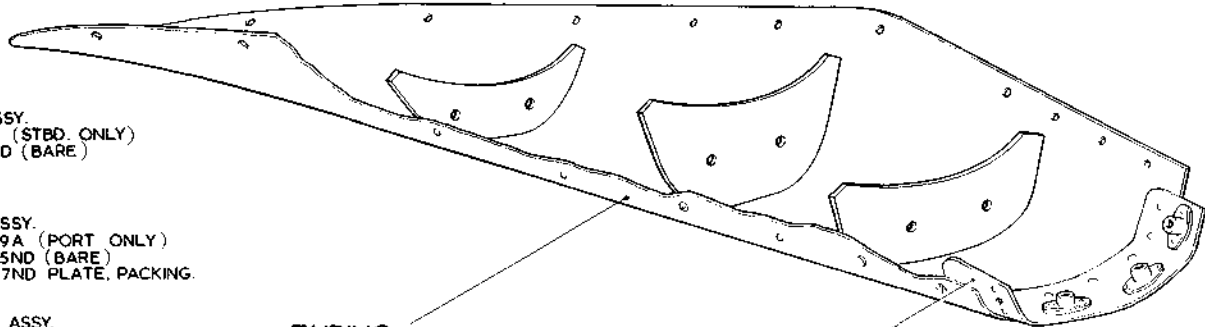

FAIRING, TAIL BOOM.
FORWARD, ASSY.
* IO.20TB 1767A

STRAP.
* IO.20 TB 1781 ND

FRAME No.1.
(REF. ONLY)

ANGLE, REINFORCING.
IO.20 TB 773ND

BRACKET, BARE.
IO.20 TB 771ND

FRAME No 2
(REF. ONLY)

BRACKET, ASSY.
IO.20 TB 769A

ANGLE.
IO.20TB 777

BRACKET, ATTACHMENT, HINGE PANEL.
IO.20 TB 1501 PORT.
IO.20 TB 1502 STBD.

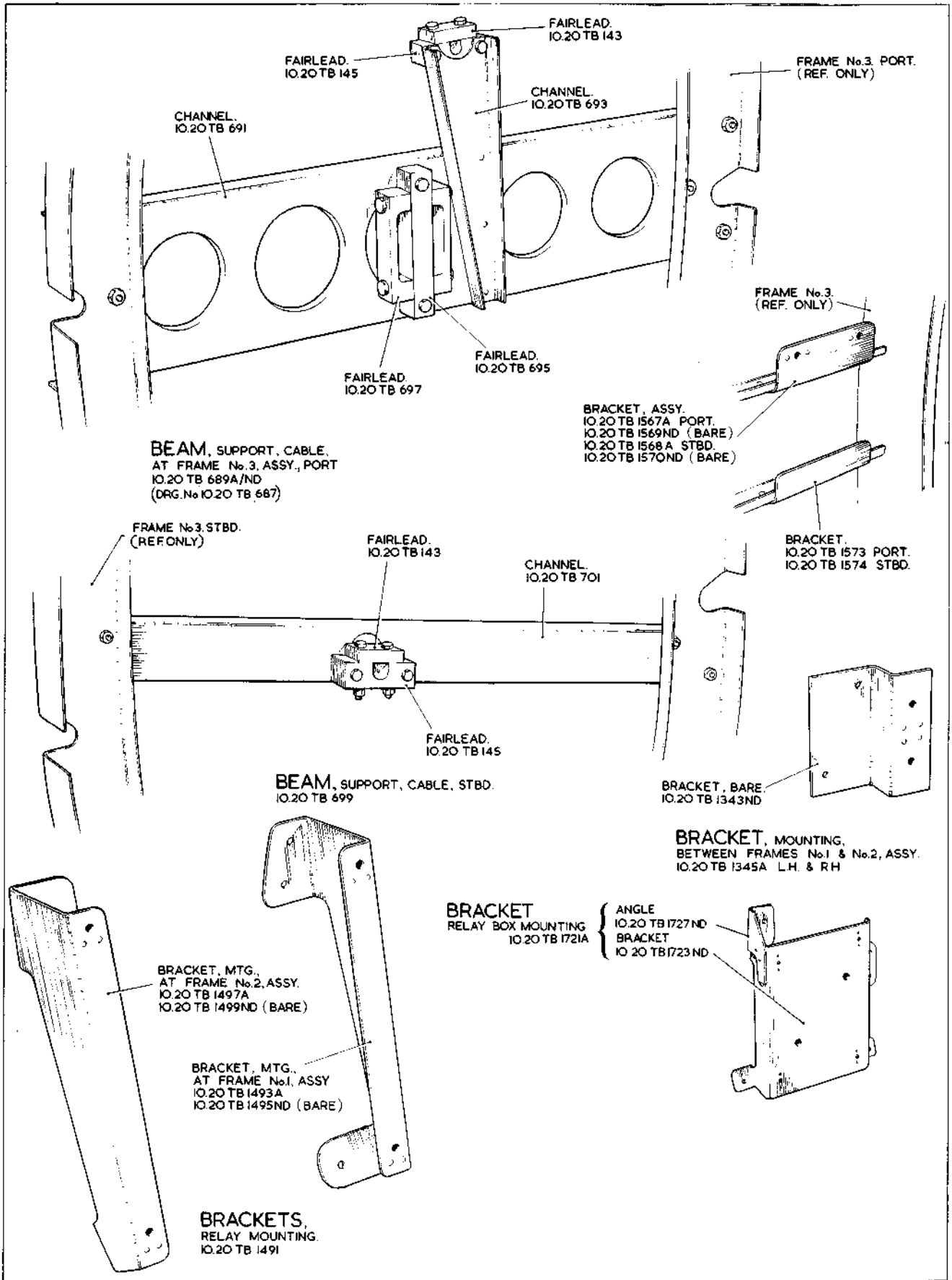

RC.12

TAIL UNIT

RC.12

FIN AND TAIL BOOM

[AL. 39]

SEE TEXT FOR SPARES CONDITION
OF ITEMS MARKED THUS: *

PLATE, SIDE, L.H.
IO.20 TB 313

PLATE, SIDE, R.H.
IO.20 TB 314

BRACKET, ASSY.
* IO.20 TB 2117A

BUSH
IO.20 TB 323

BRACKET, PIVOT, TAIL BUMPER, ASSY.

* IO.20 TB 1823A

BOLTS >
DHS 358/3E
DHS 358/4E
DHS 358/5E
DHS 358/6E

CHANNEL, BARE
IO.20 TB 335ND

PLATE, PACKING
IO.20 TB 493ND L.H.
IO.20 TB 494ND R.H.

CHANNEL, STIFFENER, ASSY.
IO.20 TB 333A

DUCT, OUTLET, FUEL VENT PIPE, PORT
IO.20 P 1071A

RC.13

TAIL UNIT

RC.13

FIN AND TAIL BOOM

[A.L.39]

SEE TEXT FOR SPARES CONDITION OF ITEMS MARKED THUS: *

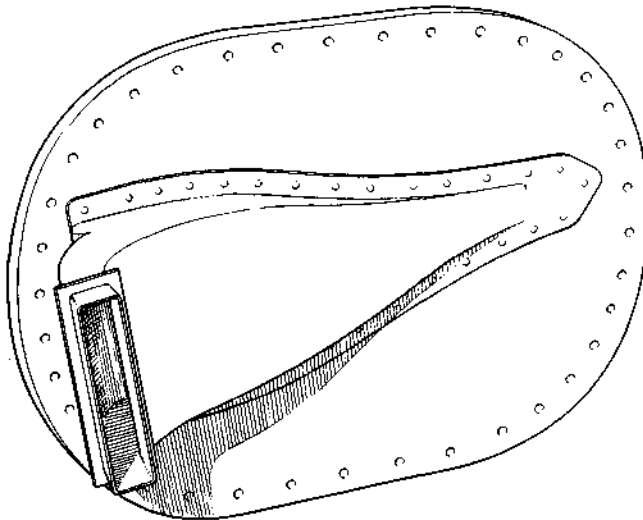

COVER, ACCESS, FLUSH AIR INTAKE, ASSY.
IO.20TB 1067A PORT OUTBD, STBD. INBD.
IO.20TB 1068A STBD. OUTBD.

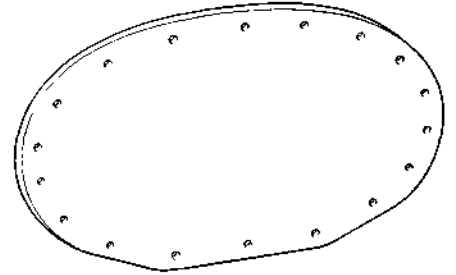

COVER-PLATE, ACCESS, HANDHOLE.
IO.20TB 363 PORT OUTBD, STBD. INBD.
IO.20TB 364 PORT INBD, STBD. OUTBD.

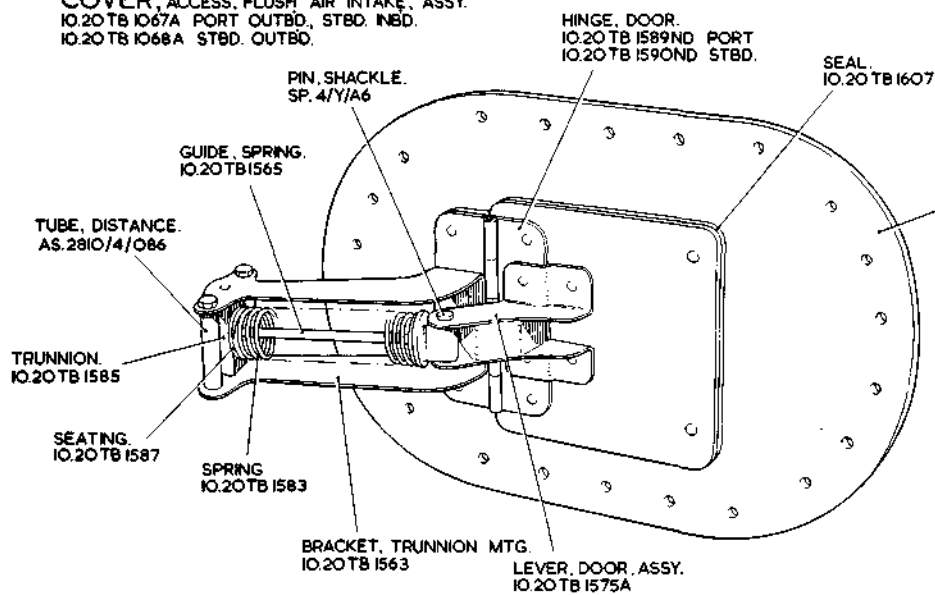

HINGE, DOOR.
IO.20TB 1589ND PORT
IO.20TB 1590ND STBD.

SEAL.
IO.20TB 1607

PIN, SHACKLE.
SP. 4/Y/A6

GUIDE, SPRING.
IO.20TB 1565

PLATE, COVER.
* IO.20TB 1591ND PORT
* IO.20TB 1592ND STBD.

TUBE, DISTANCE.
AS. 2810/4/O86

COVER-DOOR, ACCESS,
TELEBRIEF PLUG, ASSY.
IO.20TB 1673A PORT.
IO.20TB 1674A STBD.

TRUNNION.
IO.20TB 1585

SEATING.
IO.20TB 1587

SPRING
IO.20TB 1583

BRACKET, TRUNNION MTG.
IO.20TB 1563

LEVER, DOOR, ASSY.
IO.20TB 1575A

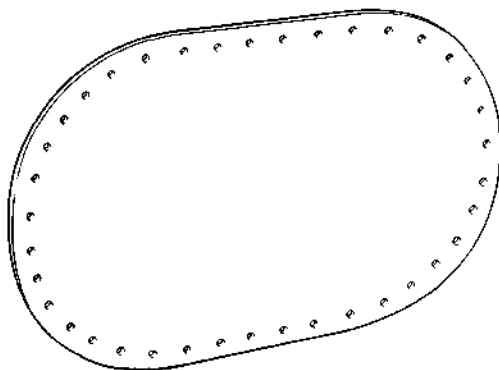

COVER, ACCESS, HANDHOLE.
IO.20TB 1065

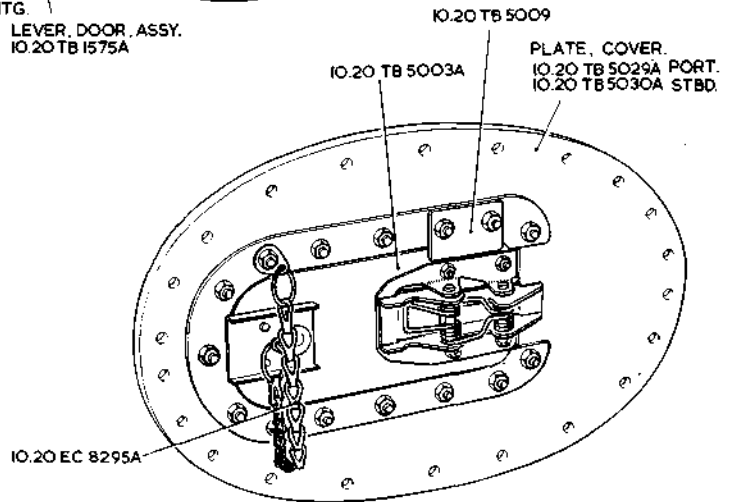

IO.20TB 5009

IO.20TB 5003A

PLATE, COVER.
IO.20TB 5029A PORT.
IO.20TB 5030A STBD.

IO.20 EC 8295A

COVER-PLATE, ACCESS, FOR HANDHOLE, ASSY.
IO.20TB 5031A PORT
IO.20TB 5032A STBD.

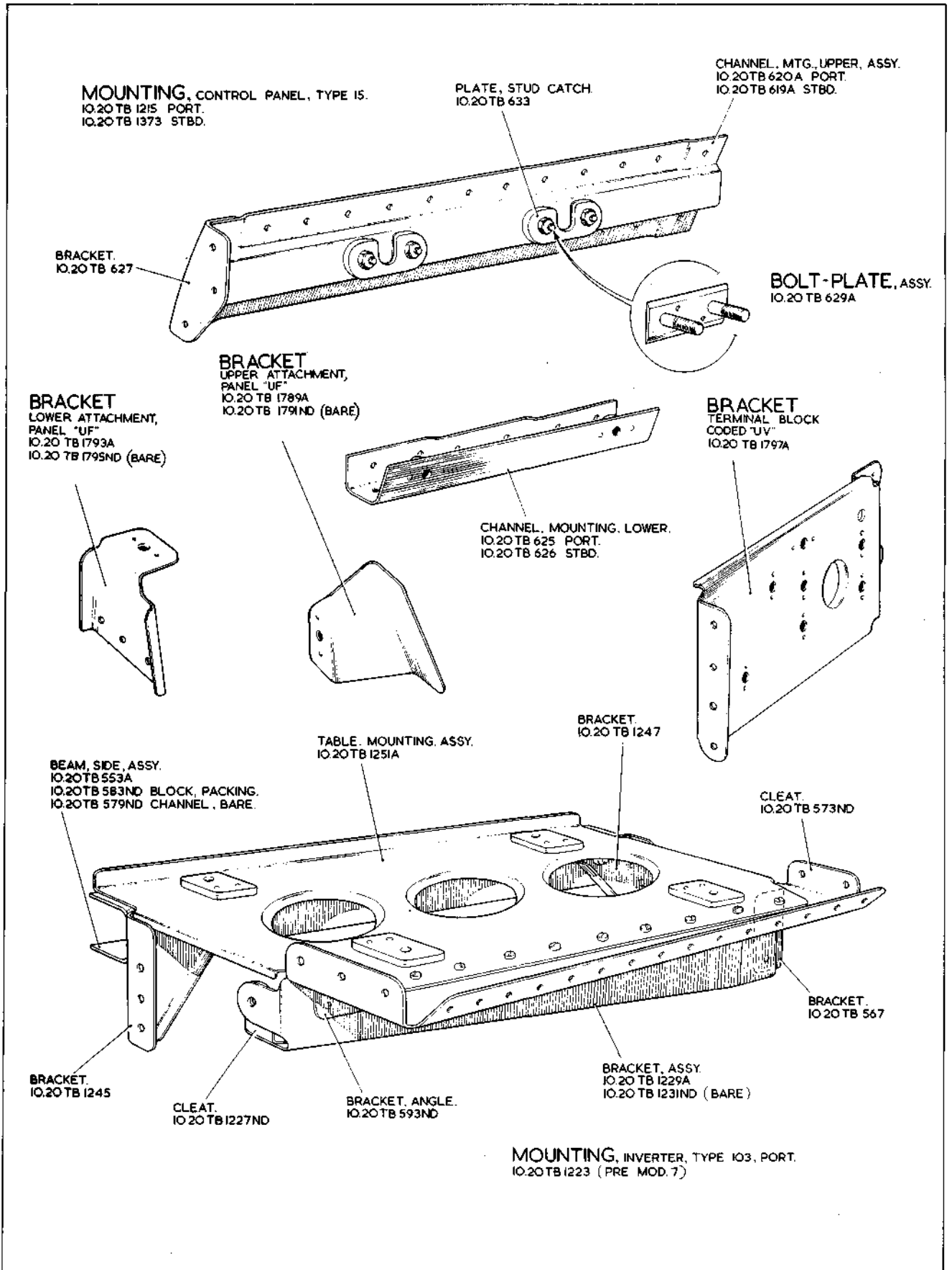

RC.16

TAIL UNIT

RC.16

[AL.39]

FIN AND TAIL BOOM

RC.17

FIN AND TAIL BOOM

TAIL UNIT

RESTRICTED

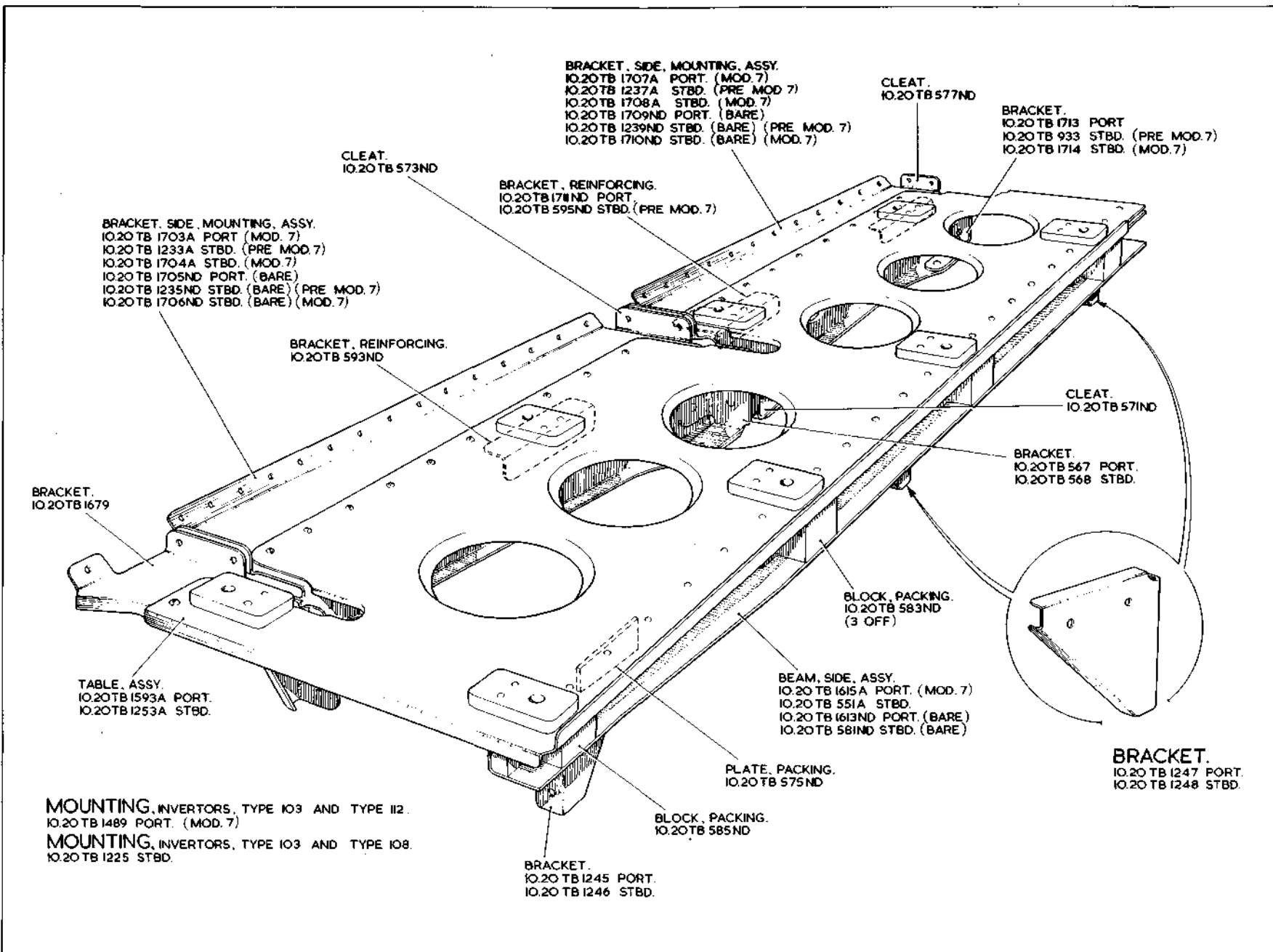

Sea Vixen Mk. 1

RESTRICTED

Plate RC17

RC.17

[A.L. 393]

SEE TEXT FOR SPARES CONDITION
OF ITEMS MARKED THUS: *

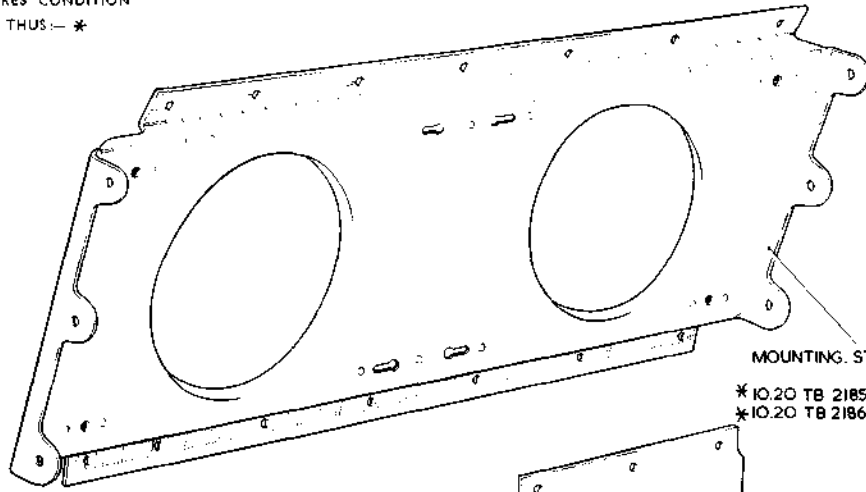

MOUNTING, STARTER UNIT, ASSY.

- * IO.20 TB 2185A/ND PORT
- * IO.20 TB 2186A/ND STBD

STUD
IO.20 TB 1805

BRACKET, MOUNTING, RELAY ASSY

- * IO.20 TB 2161A/ND

BRACKET, MOUNTING, TERMINAL, ASSY.
IO.20 TB 1801A PORT.
IO.20 TB 1802A STBD.

MOUNTING, STARTER UNIT AND RELAYS
DRG NOS. IO.20TB 1641 PORT
IO.20TB 1642 ST'BD

RC.18

TAIL UNIT

RC.18

[A.L. 62]

FIN AND TAIL BOOM

BRACKET, BARE.
IO.20 TB 1095ND
SIMILAR PART:-
IO.20 TB 1071ND

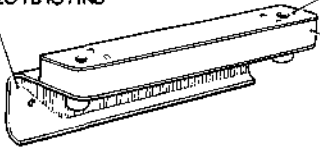
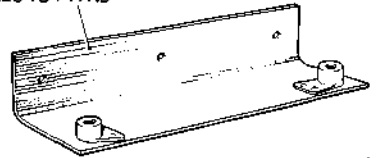

PLATE.
IO.20 TB 1097ND
SIMILAR PART:-
IO.20 TB 1073ND

BLOCK, PACKING.
IO.20 TB 923ND
SIMILAR PART:-
IO.20 TB 919ND

BRACKET, MOUNTING, ASSY.
IO.20 TB 909A-
SIMILAR PART:-
IO.20 TB 905A

BRACKET, BARE.
IO.20 TB 749ND



BRACKET, MOUNTING, ASSY.
IO.20 TB 747A

BRACKET, BARE.
IO.20 TB 869ND

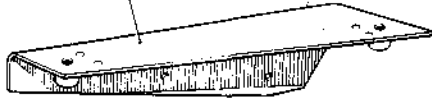

BRACKET, MOUNTING, ASSY.
IO.20 TB 871A

BRACKET, BARE.
IO.20 TB 877ND
SIMILAR PARTS:-
IO.20 TB 865ND
IO.20 TB 1051ND

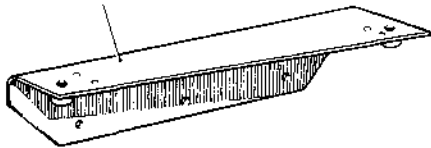

BRACKET, MOUNTING, ASSY.
IO.20 TB 879A
SIMILAR PARTS:-
IO.20 TB 867A
IO.20 TB 1053A

BRACKET, BARE.
IO.20 TB 857ND



BRACKET, MOUNTING, ASSY.
IO.20 TB 859A

BRACKET, BARE.
IO.20 TB 915ND

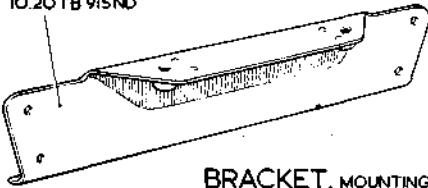

BRACKET, MOUNTING, ASSY.
IO.20 TB 913A

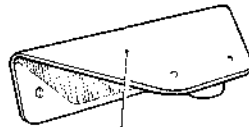

BRACKET ATTACHMENT
IO.20 TB 1785A
IO.20 TB 1787ND (BARE)

BRACKET, BARE.
IO.20 TB 2107ND
SIMILAR PARTS:-
IO.20 TB 2091ND
~~IO.20 TB 087ND~~
~~IO.20 TB 041ND~~
IO.20 TB 845ND
IO.20 TB 849ND
IO.20 TB 853ND



BRACKET, MOUNTING, ASSY
IO.20 TB 2109A
SIMILAR PARTS:-
IO.20 TB 2093A
~~IO.20 TB 089A~~
~~IO.20 TB 049A~~
IO.20 TB 847A
IO.20 TB 851A
IO.20 TB 855A

BRACKET, BARE.
IO.20 TB 895ND
SIMILAR PARTS:-
IO.20 TB 899ND
IO.20 TB 900ND
IO.20 TB 903ND



BRACKET, MOUNTING, ASSY
IO.20 TB 893A
SIMILAR PARTS:-
IO.20 TB 897A
IO.20 TB 898A
IO.20 TB 901A

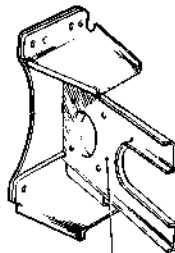

BRACKET, TELEBRIEF, ASSY.
IO.20 R 3611A PORT
IO.20 R 3612A STBD.



BRACKET, MOUNTING.
IO.20 TB 1057

BRACKET, BARE.
IO.20 TB 1381ND



BRACKET, MOUNTING, ASSY
IO.20 TB 1383A

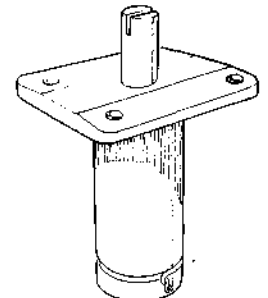

SPIGOT, JIGGING ASSY.
IO.20WC 26827A TOP CENTRE.
IO.20WC 26829A TOP AFT.
IO.20WC 26547A CENTRE INBOARD.
IO.20WC 26549A AFT INBOARD.
DHS 358/3/C
DHS 358/5/C

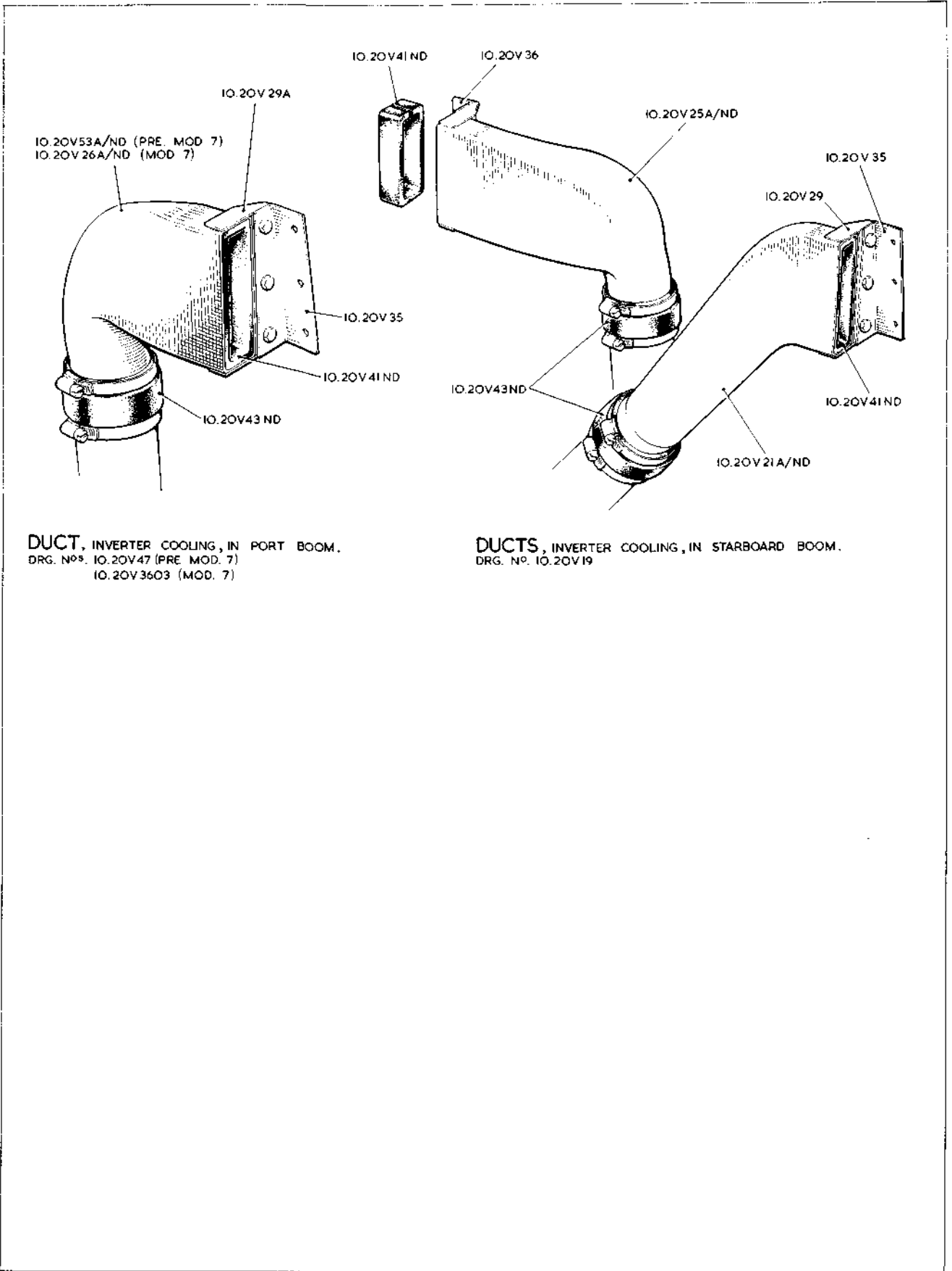

DUCT, INVERTER COOLING, IN PORT BOOM.
 DRG. NOS. IO.20V47 (PRE MOD. 7)
 IO.20V3603 (MOD. 7)

DUCTS, INVERTER COOLING, IN STARBOARD BOOM.
 DRG. NO. IO.20V19

RC.20

TAIL UNIT

RC.20
(AL.51)

FIN AND TAIL BOOM

This file was downloaded
from the RTFM Library.
Link: www.scottbouch.com/rtfm

Please see site for usage terms,
and more aircraft documents.

