

TAIL UNIT

TAILPLANE, LESS ELEVATOR

Ref. No.	Part No.	Description	No. off	Material Specification	Class of Store or LM	Place No.
164	510-20 TP B	TAILPLANE , less elevator (Special spares assembly complete with attachments) (Mod. 1112)	1	—	P	RE1
	10-20 TP 4211A	TAILPLANE , assembly (Mod. 1112)	1	—	—	RE1
13804	SKEFKO.21310	BEARING , self-aligning, tailplane pivot. Port and Starboard	2	—	C	RE4
1674	10-20 TP 341	NUT , tailplane bearing retaining, Port and Starboard	2	—	C	RE4
		Attachments for 10-20 TP 341, Nut:—				
1675	10-20 TP 339	Bolt, 2 BA, special	1	—	C	RE4
1673	10-20 TP 19	RING , tailplane main bearing, Port and Starboard	2	—	C	RE4
	10-20 TP 4187A	STRUCTURE , tailplane, assembly (Mod. 1112)	1	—	—	RE1
1655	DHS.358/3C	BOLT , 2 BA, skin attachment	290	—	C	RE2
17729	10-20 Z 33443	BOLT , special, 2 BA (Oversize replacement for 2 BA bolts at damaged holes) (Mod. 1112)	QR	—	C	
	OR					
17730	10-20 Z 33445	BOLT , special, 2 BA (Oversize replacement for 2 BA bolts at damaged holes) (Mod. 1112)	QR	—	C	
	10-20 N 10875	CONDUIT , electrical, between front and rear spars at end rib, Port, assembly	1	—	—	RE2
	10-20 N 10876A	CONDUIT , electrical, between front and rear spars at end rib, Starboard, assembly	1	—	—	RE2
		Attachments for 10-20 N 10875A or 10-20 N 10876A, Conduit at front spar:—				
28D/1010658	A25/1B	Bolt, 4 BA	1	—	C	
28E/1012874	AS.3181/16B	Clip, "P"	1	—	C	
28M/10287	AGS.2001/B/1	Nut, 4 BA	1	—	C	
		at rear spar:—				
28D/9436920	A25/1C	Bolt, 2 BA	2	—	C	
28M/10288	AGS.2001/C/1	Nut, 2 BA	2	—	C	
28W/9419402	SP.13/C	Washer	2	—	C	
	—	CONTROLS, FLYING (See sub-section CB)	—	—	—	
5K/2953	SP.40/E32	GROMMET , electrical conduit at front spar	1	—	C	
28M/10328	AGS.2002/C/1	NUT , 2 BA, skin attachment	300	—	C	
	10-20 TP 4145A	RIB , No. 1, Port, assembly (For spares use 10-20 TP 4445A/ND)	1	—	—	RE1
17809	10-20 TP 4445A/ND	RIB , No. 1, Port, assembly (Spares condition)	1	—	C	
	10-20 TP 4146A	RIB , No. 1, Starboard, assembly (For spares use 10-20 TP 4446A/ND)	1	—	—	RE1
17810	10-20 TP 4446A/ND	RIB , No. 1, Starboard, assembly (Spares condition)	1	—	C	
	10-20 TP 4147A	RIB , No. 2, Port, assembly (For spares use 10-20 TP 4447A/ND)	1	—	—	RE1
17811	10-20 TP 4447A/ND	RIB , No. 2, Port, assembly (Spares condition)	1	—	C	
	10-20 TP 4148A	RIB , No. 2, Starboard, assembly (For spares use 10-20 TP 4448A/ND)	1	—	—	RE1
17812	10-20 TP 4448A/ND	RIB , No. 2, Starboard, assembly (Spares condition)	1	—	C	
		Spares for 10-20 TP 4145A, 10-20 TP 4146A, 10-20 TP 4147A or 10-20 TP 4148A, Rib:—				

**TAIL UNIT
TAILPLANE, LESS ELEVATOR**

Ref. No.	Part No.	Description	No. off	Material Specification	Class of Store or L.M	Place No.
	10-20 TP 4149A	RIB , No. 3, Port, assembly (For spares use 10-20 TP 4449A/ND)	1	—	—	RE1
17813	10-20 TP 4449A/ND	RIB , No. 3, Port, assembly (Spares condition) Spares for 10-20 TP 4149A, Rib :—	1	—	C	
19315	10-20 TP 4065ND	ANGLE , reinforcing, aft, stringer No. 1 (Mod. 1112)	1	—	C	RE5 RE6
19316	10-20 TP 4066ND	ANGLE , reinforcing, aft, stringer No. 1 (Mod. 1112)	1	—	C	RE5 RE6
19317	10-20 TP 4067ND	ANGLE , reinforcing, forward, stringer No. 1 (Mod. 1112)	1	—	C	RE5 RE6
19318	10-20 TP 4069ND	ANGLE , reinforcing, forward, stringer No. 1 (Mod. 1112)	1	—	C	RE5 RE6
	10-20 TP 4017ND	ANGLE , reinforcing, rear spar (Mod. 1112)	1	—	—	RE5
	10-20 TP 4205ND	ANGLE , reinforcing, rear spar (Mod. 1112)	1	—	—	RE6
19305	10-20 TP 4005ND	ANGLE , reinforcing, stringer No. 2 ... (Mod. 1112)	1	—	C	RE5 RE6
19306	10-20 TP 4006ND	ANGLE , reinforcing, stringer No. 2 ... (Mod. 1112)	1	—	C	RE5 RE6
	10-20 TP 4011ND	ANGLE , reinforcing, stringer Nos. 3-10 inclusive (Mod. 1112)	8	—	—	RE5 RE6
19307	10-20 TP 4007ND	ANGLE , reinforcing, stringer No. 3 ... (Mod. 1112)	1	—	C	RE6
	10-20 TP 4003ND	ANGLE , reinforcing, stringer Nos. 4-11 inclusive (Mod. 1112)	8	—	—	RE5 RE6
	10-20 TP 4023ND	ANGLE , reinforcing, stringer No. 11 ... (Mod. 1112)	1	—	—	RE5
16541	10-20 TP 1529	FAIRLEAD Attachments for 10-20 TP 1529, Fairlead :—	1	—	C	RE1
28D/1011006	A25/5B	Bolt, 4 BA	2	—	C	
28M 10287	AGS.2001/B/1	Nut, 4 BA	2	—	C	
	10-20 TP 1357	Spacer	1	LFS.21, 23 or 26	LM	RE1 RE3
	10 CF 5371	FAIRLEAD	1	LFS.21	LM	RE1 RE3
	10-20 TP 4150A	RIB , No. 3, Starboard, assembly (For spares use 10-20 TP 4450A/ND)	1	—	—	RE1
17814	10-20 TP 4450A/ND	RIB , No. 3, Starboard, assembly (Spares condition) Spares for 10-20 TP 4150A, Rib :—	1	—	C	
19315	10-20 TP 4065ND	ANGLE , reinforcing, aft, stringer No. 1 (Mod. 1112)	1	—	C	RE5 RE6
19316	10-20 TP 4066ND	ANGLE , reinforcing, aft, stringer No. 1 (Mod. 1112)	1	—	C	RE5 RE6
19317	10-20 TP 4067ND	ANGLE , reinforcing, forward, stringer No. 1 (Mod. 1112)	1	—	C	RE5 RE6
19318	10-20 TP 4069ND	ANGLE , reinforcing, forward, stringer No. 1 (Mod. 1112)	1	—	C	RE5 RE6
	10-20 TP 4018ND	ANGLE , reinforcing, rear spar (Mod. 1112)	1	—	—	RE5
	10-20 TP 4206ND	ANGLE , reinforcing, rear spar (Mod. 1112)	1	—	—	RE6
19305	10-20 TP 4005ND	ANGLE , reinforcing, stringer No. 2 ... (Mod. 1112)	1	—	C	RE5 RE6
19306	10-20 TP 4006ND	ANGLE , reinforcing, stringer No. 2 ... (Mod. 1112)	1	—	C	RE5 RE6
19308	10-20 TP 4008ND	ANGLE , reinforcing, stringer No. 3 ... (Mod. 1112)	1	—	C	RE6

TAIL UNIT
TAILPLANE, LESS ELEVATOR

Ref. No.	Part No.	Description						No. off	Material Specification	Class of Store or L.M	Place No.
		1	2	3	4	5	6				
	10-20 TP 4012ND							8	—	—	RE5 RE6
	10-20 TP 4004ND							8	—	—	RE5 RE6
	10-20 TP 4024ND							1	—	—	RE5
	10 CF 5371							1	LFS.23	LM	RE1 RE3
	10-20 TP 4151A							1	—	—	RE1
17815	10-20 TP 4451A/ND							1	—	C	
19315	10-20 TP 4065ND							1	—	C	RE5 RE6
19316	10-20 TP 4066ND							1	—	C	RE5 RE6
19317	10-20 TP 4067ND							1	—	C	RE5 RE6
19318	10-20 TP 4069ND							1	—	C	RE5 RE6
	10-20 TP 4015ND							1	—	—	RE6
	10-20 TP 4017ND							1	—	—	RE5
19309	10-20 TP 4025ND							1	—	C	RE5
19311	10-20 TP 4027							1	—	C	RE6
	10-20 TP 4029ND							1	—	—	RE6
	10-20 TP 4011ND							7	—	—	RE5 RE6
	10-20 TP 4003ND							7	—	—	RE5 RE6
	10-20 TP 4023ND							1	—	—	RE5
	10 CF 5363							1	—	—	RE3
28D/1010030	A25/7C							1	—	C	
28M/13121	A27/CS							1	—	C	
28P/1007741	SP.9/C8							1	—	C	
	10 CF 5357A							1	—	—	RE3
	10 CF 5358A							1	—	—	RE3
1732	10 CF 5365							1	—	C	RE3
28D/1011242	A25/7E							1	—	C	
28M/1011467	A27/ES							1	—	C	
28P/1007741	SP.9/C8							1	—	C	
	10-20 TP 4152A							1	—	—	RE1
17816	10-20 TP 4452A/ND							1	—	C	
19315	10-20 TP 4065ND							1	—	C	RE5 RE6
19316	10-20 TP 4066ND							1	—	C	RE5 RE6

**TAIL UNIT
TAILPLANE, LESS ELEVATOR**

Ref. No.	Part No.	Description						No. off	Material Specification	Class of Store or L.M.	Place No.
		1	2	3	4	5	6				
19317	10-20 TP 4067ND							1	—	C	RE5 RE6
19318	10-20 TP 4069ND							1	—	C	RE5 RE6
	10-20 TP 4016ND							1	—	—	RE6
	10-20 TP 4018ND							1	—	—	RE5
19310	10-20 TP 4026ND							1	—	C	RE5
19312	10-20 TP 4028ND							1	—	C	RE6
	10-20 TP 4012ND							7	—	—	RE5 RE6
	10-20 TP 4030ND							1	—	—	RE6
	10-20 TP 4004ND							7	—	—	RE5 RE6
	10-20 TP 4024ND							1	—	—	RE5
	10 CF 5363							1	—	—	RE3
28D/1010030	A25/7C							1	—	C	
28M/13121	A27/CS							1	—	C	
28P/1007741	SP.9/C8							1	—	C	
	10 CF 5357A							1	—	—	RE3
	10 CF 5358A							1	—	—	RE3
1732	10 CF 5365							1	—	C	RE3
28D/1011242	A25/7E							1	—	C	
28M/1011467	A27/ES							1	—	C	
28P/1007741	SP.9/C8							1	—	C	
	10-20 TP 4153A							1	—	—	RE1
17817	10-20 TP 4453A/ND							1	—	C	
19315	10-20 TP 4065ND							1	—	C	RE5 RE6
19316	10-20 TP 4066ND							1	—	C	RE5 RE6
19317	10-20 TP 4067ND							1	—	C	RE5 RE6
19318	10-20 TP 4069ND							1	—	C	RE5 RE6
	10-20 TP 4021ND							1	—	—	RE5 RE6
	10-20 TP 4022ND							1	—	—	RE6
19305	10-20 TP 4005ND							1	—	C	RE5 RE6
19306	10-20 TP 4006ND							1	—	C	RE5 RE6
	10-20 TP 4003ND							9	—	—	RE5 RE6
19313	10-20 TP 4031ND							1	—	C	RE5 RE6
	10-20 TP 4011ND							8	—	—	RE5 RE6
	10 CF 5371							1	LFS.23	LM	RE1 RE3

**TAIL UNIT
TAILPLANE, LESS ELEVATOR**

Ref. No.	Part No.	Description						No. off	Material Specification	Class of Store or L.M	Place No.
		1	2	3	4	5	6				
	10-20 TP 4154A							1	—	—	RE1
17818	10-20 TP 4454A/ND							1	—	C	
19315	10-20 TP 4065ND							1	—	C	RE5 RE6
19316	10-20 TP 4066ND							1	—	C	RE5 RE6
19317	10-20 TP 4067ND							1	—	C	RE5 RE6
19318	10-20 TP 4069ND							1	—	C	RE5 RE6
	10-20 TP 4021ND							1	—	—	RE5 RE6
	10-20 TP 4022ND							1	—	—	RE6
19305	10-20 TP 4005ND							1	—	C	RE5
19306	10-20 TP 4006ND							1	—	C	RE5 RE6
	10-20 TP 4004ND							9	—	—	RE5 RE6
19314	10-20 TP 4032ND							1	—	C	RE6
	10-20 TP 4012ND							8	—	—	RE5 RE6
	10 CF 5371							1	LFS.23	LM	RE1 RE3
	10-20 TP 4155A							2	—	—	RE1
17819	10-20 TP 4455A/ND							2	—	C	
19315	10-20 TP 4065ND							1	—	C	RE5 RE6
19316	10-20 TP 4066ND							1	—	C	RE5 RE6
19317	10-20 TP 4067ND							1	—	C	RE5 RE6
19318	10-20 TP 4069ND							1	—	C	RE5 RE6
19319	10-20 TP 4077ND							1	—	C	RE5
19320	10-20 TP 4079ND							1	—	C	RE6
	10-20 TP 4021ND							1	—	—	RE5 RE6
	10-20 TP 4022ND							1	—	—	RE6
19305	10-20 TP 4005ND							1	—	C	RE5 RE6
19306	10-20 TP 4006ND							1	—	C	RE5 RE6
	10-20 TP 4003ND							8	—	—	RE5 RE6
19313	10-20 TP 4031ND							1	—	C	RE6

**TAIL UNIT
TAILPLANE, LESS ELEVATOR**

Ref. No.	Part No.	Description						No. off	Material Specification	Class of Store or L.M	Place No.
		1	2	3	4	5	6				
	10-20 TP 4011ND							7	—	—	RE5 RE6
	10-20 TP 4033ND							1	—	—	RE6
	10-20 TP 4023ND							1	—	—	RE5
	10 CF 5371							1	LFS.23	LM	RE1
17721	10-20 TP 4319							2	—	C	RE3 RE1
17720	10-20 TP 4317							2	—	C	RE1
28D/1009984	A25/7B							2	—	C	
28M/10287	AGS.2001/B/1							2	—	C	
28W/9419474	SP.15/B							2	—	C	
	10-20 TP 4156A							1	—	—	RE1
17820	10-20 TP 4456A/ND							1	—	C	
19315	10-20 TP 4065ND							1	—	C	RE5 RE6
19316	10-20 TP 4066ND							1	—	C	RE5 RE6
19317	10-20 TP 4067ND							1	—	C	RE5 RE6
19318	10-20 TP 4069ND							1	—	C	RE5 RE6
	10-20 TP 4021ND							1	—	—	RE5 RE6
	10-20 TP 4022ND							1	—	—	RE6
19305	10-20 TP 4005ND							1	—	C	RE5 RE6
19306	10-20 TP 4006ND							1	—	C	RE5 RE6
	10-20 TP 4004ND							8	—	—	RE5 RE6
	10-20 TP 4032ND							1	—	—	RE6
	10-20 TP 4012ND							7	—	—	RE5 RE6
	10-20 TP 4034ND							1	—	—	RE6
	10-20 TP 4024ND							1	—	—	RE5
	10 CF 5371							1	LFS.23	LM	RE1 RE3
								Attachments for 10-20 TP 4149A, 10-20 TP 4150A, 10-20 TP 4151A, 10-20 TP 4152A, 10-20 TP 4153A, 10-20 TP 4154A, 10-20 TP 4155A or 10-20 TP 4156A, Rib :—			
1654	DHS.358/2C							6	—	C	RE1
28M/10288	AGS.2001/C/1							6	—	C	
28W/9419475	SP.15/C							6	—	C	
1714	10 TP 1099							2	—	C	RE1

**TAIL UNIT
TAILPLANE, LESS ELEVATOR**

Ref. No.	Part No.	Description	No. off	Material Specification	Class of Store or L.M.	Place No.
	—	RIB , end, group (Drg. No. 10-20 TP 185) ...	1	—	—	
	10 TP 1079	ANGLE , reinforcing ...	8	DTD.364	LM	RE2
		Attachments for 10 TP 1079, Angle :—				
1657	DHS.365/3E	Bolt, 1/4" BSF ...	2	—	C	RE2
28M/10290	AGS.2001/E/1	Nut, 1/4" BSF ...	2	—	C	
1654	DHS.358/2C	BOLT , 2 BA, skin attachment, at rib No. 1	4	—	C	RE2
17727	10-20 Z 33439	BOLT , special, 2 BA, skin attachment, at rib No. 1 (Oversize replacement for 2 BA bolts at damaged holes) (Mod. 1112)	QR	—	C	
17728	10-20 Z 33441	BOLT , special, 2 BA, skin attachment at rib No. 1 (Oversize replacement for 2 BA bolts at damaged holes) (Mod. 1112)	QR	—	C	
1745	10 TP 1077A	BRACKET , attachment for front spar, L.H., assembly	2	—	C	RE2
1746	10 TP 1078A	BRACKET , attachment for front spar, R.H., assembly	2	—	C	RE2
		Attachments for 10 TP 1077A or 10 TP 1078A, Bracket :—				
28D/8307	AS.1242/2C	Bolt, 2 BA ...	1	—	C	
	10-20 N 447	BRACKET , cable guide, Port, 18 SWG ...	1	L.72	LM	RE2
	10-20 N 448	BRACKET , cable guide, Starboard, 18 SWG	1	L.72	LM	RE2
		Attachments for 10-20 N 447 or 10-20 N 448, Bracket :—				
1654	DHS.358/2C	Bolt, 2 BA ...	2	—	C	RE2
28M/10288	AGS.2001/C/1	Nut, 2 BA ...	2	—	C	
1735	10 TP 783	FORK , tailplane actuating, Port ...	1	—	P	RE2
1736	10 TP 784	FORK , tailplane actuating, Starboard ...	1	—	P	RE2
		Attachments for 10 TP 783 or 10 TP 784, Fork :—				
1653	DHS.365/2E	Bolt, 1/4" BSF ...	4	—	C	RE2
1657	DHS.365/3E	Bolt, 3/8" BSF ...	26	—	C	RE2
1749	10-20 TP 131	Bolt, 1/4" BSF, special ...	2	—	C	RE2
28D/14582	A30/6I	Bolt, 3/8" BSF ...	6	—	C	
28M 10290	AGS.2001/E/1	Nut, 1/4" BSF ...	26	—	C	
28M/13289	A27/JC	Nut, 3/8" BSF ...	6	—	C	
28P/1007741	SP.9/C8	Pin, split ...	6	—	C	
28W/9419405	SP.15/E	Washer ...	12	—	C	
28W/9419487	SP.16/E	Washer ...	4	—	C	
28W/9419477	SP.15/J	Washer ...	6	—	C	
5K/—	AS.3360/B10C	LEAD , bonding, flexible ...	1	—	C	
		Attachments for AS.3360/B10C, Lead :—				
5612	A25/1B/DHS.S14/D	Bolt, 4 BA ...	1	—	C	
28W/9419465	SP.13/B	Washer ...	1	—	C	
28M/10238	AGS.2002/C/1	NUT , 2 BA, skin attachment, at rib No. 1	4	—	C	

TAIL UNIT

TAILPLANE, LESS ELEVATOR

Ref. No.	Part No.	Description	No. off	Material Specification	Class of Store or L.M	Plate No.
1733	10-20 TP 337	PIVOT , front, Port	1	DTD.666	C	RE2
1734	10-20 TP 338	PIVOT , front, Starboard	1	DTD.666	C	RE2
		Attachments for 10-20 TP 337 or 10-20 TP 338. Pivot :—				
1657	DHS.365/3E	Bolt, 1/4" BSF	26	S.96	C	RE2
1747	10-20 TP 127	Bolt, 1/4" BSF, special	4	S.96	C	RE2
1748	10-20 TP 129	Bolt, 1/4" BSF, special	2	S.96	C	RE2
28D/14582	A30/6J	Bolt, 3/8" BSF	6	—	C	
28M/10290	AGS.2001/E/1	Nut, 1/2" BSF	26	—	C	
28M/13289	A27/JC	Nut, 3/8" BSF	6	—	C	
28P/1007741	SP.9/C8	Pin, split	6	—	C	
28W/9419405	SP.15/E	Washer	4	—	C	
28W/9419477	SP.15/J	Washer	6	—	C	
1744	10-20 TP 301	PLATE , cover, aft	1	L.72	C	RE2
1743	10-20 TP 303	PLATE , cover, centre, centre aft and centre intermediate	3	L.72	C	RE2
1742	10-20 TP 1253	PLATE , cover, centre forward	1	L.72	C	RE2
1740	10-20 TP 307	PLATE , cover, forward	1	L.72	C	RE2
1741	10-20 TP 305	PLATE , cover, forward intermediate	1	L.72	C	RE2
	10-20 TP 891A	RIB , end, Port, assembly (Mod. 644) (For spares use 10-20 TP 1491A/ND)	1	—	—	RE1
15111	10-20 TP 1491A/ND	RIB , end, Port, assembly (Spares condition)	1	—	P	
	10-20 TP 892A	RIB , end, Starboard, assembly (Mod. 644) (For spares use 10-20 TP 1492A/ND)	1	—	—	RE1
15112	10-20 TP 1492A/ND	RIB , end, Starboard, assembly (Spares condition)	1	—	P	
1739	10 TP 1343	Spares for :— BUSH (See Repair section PA) ...	1	S.1	C	RE3
		Attachments for 10-20 TP 891A or 10-20 TP 892A, Rib :—				
1655	DHS.358/3C	Bolt, 2 BA	14	S.96	C	RE1
1657	DHS.365/3E	Bolt, 1/4" BSF	32	S.96	C	RE1
26DV/5897	DHS.365/4E	Bolt, 1/4" BSF	22	S.96	C	RE1
1793	DHS.365/5E	Bolt, 1/4" BSF	16	S.96	C	RE1
1794	DHS.365/6E	Bolt, 1/4" BSF	17	S.96	C	RE1
1795	DHS.365/8E	Bolt, 1/4" BSF	1	S.96	C	RE1
1785	10-20 TP 123	Bolt, 1/4" BSF, special	11	S.80	C	RE3
17731	10-20 Z 32651	Bolt, special, 3/8" (Oversize replacement for 10-20 TP 123 at damaged holes) (Mod. 1112)	QR	S.80	C	RE3
5875	10-20 TP 125	Bolt, 1/4" BSF, special	2	S.80	C	RE3
17732	10-20 Z 32673	Bolt, special, 3/8" (Oversize replacement for 10-20 TP 125 at damaged holes) (Mod. 1112)	QR	S.80	C	RE3
28M/10288	AGS.2001/C/1	Nut, 2 BA	14	—	C	
28M/10290	AGS.2001/E/1	Nut, 1/2" BSF	87	—	C	
28M/10340	AGS.2002/E/2	Nut, 1/2" BSF	14	—	C	
28W/9419405	SP.15/E	Washer	87	—	C	
26DL/7354	DHS.180.Mk.1/X	TAG , bonding lead attachment	1	S.510	C	RE1
	DHS.727/C16	WASHER , skin attachment at rib No. 1	4	DTD.746	LM	RE1

TAIL UNIT

TAILPLANE, LESS ELEVATOR

Ref. No.	Part No.	Description						No. off	Material Specification	Class of Store of L.M.	Plate No.
		1	2	3	4	5	6				
	10-20 TP 549A										
14334	10-20 TP 849A/ND										
	10-20 TP 591										
5873	10-20 TP 1469ND										
1654 28M/1006473 28W/9419475	DHS.358/2C A27/CT SP.15/C										
	10-20 TP 557A/1										
14338	10-20 TP 857A/ND										
	—										
	10-20 TP 75										
1759	10-20 TP 1467ND										
	10-20 TP 76										
1760	10-20 TP 1468ND										
1654 28M/10328 28W/9419475	DHS.358/2C AGS.2002/C/1 SP.15/C										
15877	10-20 TP 1497A										
28D/8322 28D/1013177	AS.1242/1E AS.1242/2E										
	10-20 TP 327ND										
1655 28M/10328 28W/9419475 28W/9419404 1714	DHS.358/3C AGS.2002/C/1 SP.15/C SP.16/C 10 TP 1099 10-20 TP 1347ND										

**TAIL UNIT
TAILPLANE, LESS ELEVATOR**

Ref. No.	Part No.	Description						No. off	Material Specification	Class of Store or L.M	Place No.
		1	2	3	4	5	6				
	10-20 TP 317ND							2	DTD.687	LM	RE2
	10-20 TP 329ND							2	DTD.687	LM	RE2
								Attachments for 10-20 TP 317ND or 10-20 TP 329ND, Plate :-			
1655	DHS.358/3C							12	S.96	C	RE2
28M/10328	AGS.2002/C/1							12	—	C	
28W/9419475	SP.15/C							4	—	C	
28W/9419404	SP.16/C							4	—	C	
1714	10 TP 1099							2	L.72	C	RE2
	10-20 TP 713							2	L.72	—	RE2
	10-20 TP 331ND							7	DTD.687	LM	RE2
								Attachments for 10-20 TP 331ND, Plate :-			
1655	DHS.358/3C							12	S.96	C	RE2
28M/10328	AGS.2002/C/1							12	—	C	
28W/9419475	SP.15/C							2	—	C	
28W/9419404	SP.16/C							6	—	C	
1714	10 TP 1099							2	L.72	C	RE2
	10-20 TP 1347ND							2	L.72	—	RE2
	10-20 TP 325ND							2	DTD.687	—	RE2
14580	10-20 TP 843ND							2	DTD.687	C	
								Attachments for 10-20 TP 325ND, Strap :-			
1654	DHS.358/2C							72	S.96	C	RE2
1655	DHS.358/3C							6	S.96	C	RE2
28M/10328	AGS.2002/C/1							78	—	C	
28W/9419475	SP.15/C							72	—	C	
28W/9419404	SP.16/C							6	—	C	
	10-20 TP 333ND							1	DTD.687	—	RE2
14581	10-20 TP 845ND							1	DTD.687	C	
								Attachments for 11-20 TP 333ND, Strap :-			
1654	DHS.358/2C							12	S.96	C	RE2
28M/10328	AGS.2002/C/1							12	—	C	
28W/9419475	SP.15/C							12	—	C	
	—							1	—	—	
1199	DHS.358/1C							4	S.96	C	RE3
1654	DHS.358/2C							12	S.96	C	RE3
1655	DHS.358/3C							20	S.96	C	RE3

**TAIL UNIT
TAILPLANE, LESS ELEVATOR**

Ref. No.	Part No.	Description	No. off	Material Specification	Class of Store or L.M.	Plate No.
17727	10-20 Z 33439	BOLT , special, 2 BA (Oversize replacement for 2 BA bolts at damaged holes) (Mod. 1112)	QR	S.96	C	
17728	10-20 Z 33441	BOLT , special, 2 BA (Oversize replacement for 2 BA bolts at damaged holes) (Mod. 1112)	QR	S.96	C	
17729	10-20 Z 33443	BOLT , special, 2 BA (Oversize replacement for 2 BA bolts at damaged holes) (Mod. 1112)	QR	S.96	C	
17730	10-20 Z 33445	BOLT , special, 2 BA (Oversize replacement for 2 BA bolts at damaged holes) (Mod. 1112)	QR	S.96	C	
	10-20 TP 65	CAPPING , stringers Nos. 4 and 5, between ribs Nos. 0 and 4, Port (For spares use 10-20 TP 1473ND)	1	DTD.687	—	RE3
1753	10-20 TP 1473ND	CAPPING , stringers Nos. 4 and 5, between ribs Nos. 0 and 4, Port (Spares condition)	1	DTD.687	C	
	10-20 TP 66	CAPPING , stringers Nos. 4 and 5, between ribs Nos. 0 and 4, Starboard (For spares use 10-20 TP 1474ND)	1	DTD.687	—	RE3
1754	10-20 TP 1474ND	CAPPING , stringers, Nos. 4 and 5, between ribs Nos. 0 and 4, Starboard (Spares condition)	1	DTD.687	C	
		Attachments for 10-20 TP 65 or 10-20 TP 66, Capping :—				
1654	DHS.358/2C	Bolt, 2 BA	7	S.96	C	RE3
28M/10328	AGS.2002/C/1	Nut, 2 BA	7	—	C	
28W/9419475	SP.15/C	Washer	7	—	C	
	10-20 TP 321	CAPPING , stringer No. 6, between rib Nos. 0 and 3, Port and Starboard (For spares use 10-20 TP 1471ND)	2	L.73	—	RE3
1755	10-20 TP 1471ND	CAPPING , stringer No. 6, between rib Nos. 0 and 3, Port and Starboard (Spares condition)	2	L.73	C	
		Attachments for 10-20 TP 321, Capping :—				
1654	DHS.358/2C	Bolt, 2 BA	4	S.96	C	RE3
28M/10328	AGS.2002/C/1	Nut, 2 BA	4	—	C	
28W/9419475	SP.15/C	Washer	4	—	C	
28M/10328	AGS.2002/C/1	NUT , 2 BA, skin attachments, Port and Starboard	450	—	C	
1756	10-20 TP 1289	PLATE , doubling, between ribs Nos. 1 and 3, Port and Starboard	2	DTD.746	C	RE3
	10-20 TP 1291ND	PLATE , packing, under stringer capping, Port and Starboard, 20 SWG	2	DTD.796	LM	RE2
	10-20 TP 311ND	PLATE , reinforcing, at rib No. 1, Port and Starboard, 20 SWG	2	DTD.687	LM	RE2
	10-20 TP 313ND	PLATE , reinforcing, at ribs Nos. 2 and 3, Port and Starboard, 20 SWG	2	DTD.687	LM	RE3
	10-20 TP 317ND	PLATE , reinforcing, at ribs Nos. 4, 5 and 6, Port and Starboard, and rib No. 7, 18 SWG	7	DTD.687	LM	RE2

TAIL UNIT

TAILPLANE, LESS ELEVATOR

Ref. No.	Part No.	Description	No. off	Material Specification	Class of Store or L.M.	Plate No.
		Attachments for 10-20 TP 311ND, 10-20 TP 313ND or 10-20 TP 317ND, Plate :—				
1655	DHS.358/3C	Bolt, 2 BA	12	S.96	C	RE2
28M/10328	AGS.2002/C/1	Nut, 2 BA	12	—	C	
28W/9419475	SP.15/C	Washer	4	—	C	
28W/9419404	SP.16/C	Washer	4	—	C	
1714	10 TP 1099	Washer, packing	4	L.72	C	RE2
	10-20 TP 589ND	STRAP , doubling, between rib No. 3, Port and rib No. 3, Starboard (For spares use 10-20 TP 851ND)	1	DTD.746	—	RE2
14337	10-20 TP 851ND	STRAP , doubling, between rib No. 3, Port and rib No. 3, Starboard (Spares condition)	1	DTD.746	C	
	10-20 TP 315ND	STRAP , joint, between ribs Nos. 0 and 4, Port and Starboard (For spares use 10-20 TP 819ND)	2	DTD.687	—	RE3
13683	10-20 TP 819ND	STRAP , joint, between ribs Nos. 0 and 4, Port and Starboard (Spares condition)	2	DTD.687	C	
		Attachments for 10-20 TP 315ND, Scrap :—				
1654	DHS.358/2C	Bolt, 2 BA	102	S.96	C	RE3
1655	DHS.358/3C	Bolt, 2 BA	22	S.96	C	RE3
28M/10328	AGS.2002/C/1	Nut, 2 BA	124	—	C	
28W/9419475	SP.15/C	Washer	102	—	C	
28W/9419404	SP.16/C	Washer	22	—	C	
	10-20 TP 319ND	STRAP , joint, between rib No. 3, Port and rib No. 3, Starboard (For spares use 10-20 TP 821ND)	2	DTD.687	—	RE3
13684	10-20 TP 821ND	STRAP , joint, between rib No. 3, Port and rib No. 3, Starboard (Spares condition)	2	DTD.687	C	
		Attachments for 10-20 TP 319ND, Strap :—				
1199	DHS.358/1C	Bolt, 2 BA	4	S.96	C	RE3
28M/10328	AGS.2002/C/1	Nut, 2 BA	4	—	C	
28W/9419475	SP.15/C	Washer	4	—	C	
28W/9419475	SP.15/C	WASHER , skin attachment, Port and Starboard	278	—	C	
28W/9419404	SP.16/C	WASHER , skin attachment, Port and Starboard	96	—	C	
1714	10 TP 1099	WASHER , packing, skin attachment, Port and Starboard	72	L.72	C	RE2
	10-20 TP 4199A	SKIN , leading edge, assembly (Mod. 1112) (For spares use 10-20 TP 4463A/ND)	1	—	—	RE1
18334	10-20 TP 4463A/ND	SKIN , leading edge, assembly (Spares condition)	1	—	C	
		Spares for :—				
	10-20 TP 1263A	BRACKET , tailplane slinging, assembly	1	—	—	RE4
	10-20 TP 1265	BRACKET , bare	1	L.53	—	RE4
28M/—	AGS.2008/L/1	NUT , anchor, 1/8" BSF	1	—	C	
28M/12931	A27/ET	NUT , 1/2" BSF	1	—	C	
1719	10-20 TP 1267	SPINDLE	1	S.110	C	RE4
1458	DHS.775/E1	WASHER	1	S.510	C	RE4
		Attachments for 10-20 TP 1263A, Bracket :—				
28D/1008149	A25/2B	Bolt, 4 BA	4	—	C	
28M/10287	AGS.2001/B/1	Nut, 4 BA	4	—	C	
28W/9419474	SP.15/B	Washer	4	—	C	

TAIL UNIT
TAILPLANE, LESS ELEVATOR

Ref. No.	Part No.	Description						No. off	Material Specification	Class of Store or L.M.	Place No.
		1	2	3	4	5	6				
	10-20 TP 1269							1	DTD.746	LM	RE4
	10-20 TP 4163A							12	—	—	RE1
17821	10-20 TP 4457A/ND							12	—	C	
	10-20 TP 4165A							1	—	—	RE1
17822	10-20 TP 4459A/ND							1	—	C	
28D/9133012	A25/3C							3	—	C	
28W/9419475	SP.15/C							3	—	C	
	10-20 TP 195ND							1	L.73	—	RE1
1654	DHS.358/2C							156	S.96	C	RE1
1092	DHS.365/2C							78	S.96	C	RE1
5554	DHS.365/2CC							26	S.96	C	RE1
28M/10288	AGS.2001/C/1							104	—	C	
28M/10328	AGS.2002/C/1							156	—	C	
28W/9419475	SP.15/C							156	—	C	
	10-20 TP 53A/1							1	—	C	RE1
14339	10-20 TP 859A/ND							1	—	C	
	10-20 TP 43							4	L.73	—	RE3
1765	10-20 TP 1461ND							4	L.73	C	
	10-20 TP 47							1	L.73 or DTD.746	—	RE3
1762	10-20 TP 1465ND							1	L.73 or DTD.746	C	
	10-20 TP 48							1	L.73 or DTD.746	—	RE3
1763	10-20 TP 1466ND							1	L.73 or DTD.746	C	
1654	DHS.358/2C							14	S.96	C	RE3
28M/1006473	A27/CT							14	—	C	
28W/9419475	SP.15/C							14	—	C	
	10-20 TP 45							2	L.73	—	RE3
1764	10-20 TP 1463ND							2	L.73	C	
1654	DHS.358/2C							12	S.96	C	RE3
28M/1006473	A27/CT							12	—	C	
28W/9419475	SP.15/C							12	—	C	

**TAIL UNIT
TAILPLANE, LESS ELEVATOR**

Ref. No.	Part No.	Description	No. off	Material Specification	Class of Store or L.M	Plate No.
	10-20 TP 1273A	SKIN , top, front, assembly (For spares use 10-20 TP 853A/ND)	1	—	—	RE1
14335	10-20 TP 853A/ND	SKIN , top, front, assembly (Spares condition)	1	—	C	
	10-20 TP 175A	SPAR , front, assembly	1	—	—	RE1
	10-20 TP 205ND	PLATE , reinforcing, Port, 22 SWG	1	DTD.687	—	RE2
	10-20 TP 206ND	PLATE , reinforcing, Starboard, 22 SWG	1	DTD.687	—	RE2
	10-20 TP 207ND	PLATE , reinforcing, Port and Starboard, 16 SWG	2	DTD.687	—	RE2
	10-20 TP 203ND	SPAR , bare, 16 SWG	1	DTD.687	—	RE1
28D/1011238	A25/3E	Attachments for 10-20 TP 175A, Spar :—				
1653	DHS.365/2E	Bolt, 1/4" BSF	6	—	C	
17722	10-20 Z 32641	Bolt, 1/4" BSF	260	S.96	C	RE1
		Bolt, special, 1/8" BSF (Oversize replacement for 1/4" BSF bolts at damaged holes) (Mod. 1112)	QR	S.96	C	RE1
17723	10-20 Z 32643	Bolt, special, 1/8" BSF (Oversize replacement for 1/4" BSF bolts at damaged holes) (Mod. 1112)	QR	S.96	C	RE1
17724	10-20 Z 32645	Bolt, special, 1/8" BSF (Oversize replacement for 1/4" BSF bolts at damaged holes) (Mod. 1112)	QR	S.96	C	RE1
17725	10-20 Z 32647	Bolt, special, 1/8" BSF (Oversize replacement for 1/4" BSF bolts at damaged holes) (Mod. 1112)	QR	S.96	C	RE1
17726	10-20 Z 32649	Bolt, special, 1/8" BSF (Oversize replacement for 1/4" BSF bolts at damaged holes) (Mod. 1112)	QR	S.96	C	RE1
28M/10290	AGS.2001/E/1	Nut, 1/8" BSF	260	—	C	
28M/12928	A27/EP	Nut, 1/4" BSF	6	—	C	
28WV/9419405	SP.15/E	Washer	222	—	C	
28WV/9419487	SP.16/E	Washer	56	—	C	
	—	SPAR , rear, and shroud, group (Drg. No. 10-20 TP 4203) (Mod. 1112) Spares for :—	1	—	—	
1694	10 TP 1245	BLOCK , L.H., top and bottom packing, all elevator hinges	8	L.64	C	RE2
1695	10 TP 1246	BLOCK , R.H. top and bottom packing, all elevator hinges	8	L.64	C	RE2
		Attachments for 10 TP 1245 or 10 TP 1246, Block :—				
1660	DHS.358/4C	Bolt, 2 BA	1	S.96	C	RE2
1788	DHS.358/6C	Bolt, 2 BA	1	S.96	C	RE2
1789	DHS.358/7C	Bolt, 2 BA	1	S.96	C	RE2
28M/10328	AGS.2002/C/1	Nut, 2 BA	3	—	C	
7199	DHS.358/1 1/2 C	BOLT , 2 BA, skin attachment	24	S.96	C	RE2
1654	DHS.358/2C	BOLT , 2 BA, skin attachment	53	S.96	C	RE2
2346	DHS.358/2 1/2 C	BOLT , 2 BA, skin attachment	2	S.96	C	RE2
2347	DHS.358/3 1/2 C	BOLT , 2 BA, skin attachment	24	S.96	C	RE2
1092	DHS.365/2C	BOLT , 2 BA, skin attachment	96	S.96	C	RE2
2729	DHS.365/3 1/2 C	BOLT , 2 BA, skin attachment	48	S.96	C	RE2
17727	10-20 Z 33439	BOLT , special, 2 BA, skin attachment (Oversize replacement for 2 BA bolts at damaged holes) (Mod. 1112)	QR	S.96	C	RE2

TAIL UNIT

TAILPLANE, LESS ELEVATOR

Ref. No.	Part No.	Description						No. off	Material Specification	Class of Score or L.M	Place No.
		1	2	3	4	5	6				
17728	10-20 Z 33441							QR	S.96	C	
17729	10-20 Z 33443							QR	S.96	C	
17730	10-20 Z 33445							QR	S.96	C	
	10-20 TP 647							1	DTD.304	—	RE2
10361	10-20 TP 771ND							1	DTD.304	C	
	10-20 TP 648							1	DTD.304	—	RE2
10362	10-20 TP 772ND							1	DTD.304	C	
	10-20 TP 571A							4	—	—	RE2
8337	10-20 TP 1475A/ND							4	—	C	
	10-20 TP 1093							1	S.1	—	RE2
	10-20 TP 1095							1	S.1	—	RE2
1654	DHS.358/2C							8	S.96	C	RE2
28M/10288	AGS.2001/C/1							8	—	C	
28W/9419475	SP.15/C							8	—	C	
	10-20 TP 643A							1	—	—	RE4
11450	10-20 TP 753A/ND							1	—	C	
	10-20 TP 644A							1	—	—	RE4
11451	10-20 TP 754A/ND							1	—	C	
	Attachments for 10-20 TP 643A or 10-20 TP 644A, Lug :—							2	—	C	
28D/9133011	A25/2C							2	—	C	
28M/9637	AGS.2003/C/1							2	—	C	
28M/1006473	A27/CT							55	—	C	
28M/10288	AGS.2001/C/1							192	—	C	
28M/9637	AGS.2003/C/1							14	—	C	
28M/10245	AGS.2014/C/11							4	—	C	
	10-20 TP 653A							1	—	—	RE2
9060	10-20 TP 1433A/ND							1	—	C	

**TAIL UNIT
TAILPLANE, LESS ELEVATOR**

Ref. No.	Part No.	Description						No. off	Material Specification	Class of Store or L.M.	Plate No.
		1	2	3	4	5	6				
	10-20 TP 654A							1	—	—	RE2
9061	10-20 TP 1434A/ND							1	—	C	
28D/9436920	A25/1C							6	—	C	
	10-20 TP 655							1	L.73	—	RE2
9062	10-20 TP 1437ND							1	L.73	C	
	10-20 TP 656							1	L.73	—	RE2
9063	10-20 TP 1438ND							1	L.73	C	
28D/9436920	A25/1C							3	—	C	
28M/1006473	A27/CT							3	—	C	
28W/9419475	SP.15/C							3	—	C	
	10-20 TP 657							1	L.73	—	RE2
9064	10-20 TP 1439ND							1	L.73	C	
	10-20 TP 658							1	L.73	—	RE2
9065	10-20 TP 1440ND							1	L.73	C	
28D/9436920	A25/1C							4	—	C	
28M/1006473	A27/CT							4	—	C	
28W/9419475	SP.15/C							4	—	C	
	10-20 TP 659							1	L.73	—	RE2
9066	10-20 TP 1441ND							1	L.73	C	

TAIL UNIT

TAILPLANE, LESS ELEVATOR

Ref. No.	Part No.	Description						No. off	Material Specification	Class of Score or L.M	Plate No.
		1	2	3	4	5	6				
	10-20 TP 660							1	L.73	—	RE2
9067	10-20 TP 1442ND							1	L.73	C	
28D/9436920	A25/1C							3	—	C	
28M/1006473	A27/CT							3	—	C	
28W/9419475	SP.15/C							3	—	C	
	10-20 TP 661							1	L.73	—	RE2
9068	10-20 TP 1443ND							1	L.73	C	
	10-20 TP 662							1	L.73	—	RE2
9069	10-20 TP 1444ND							1	L.73	C	
28D/9436920	A25/1C							5	—	C	
28M/1006473	A27/CT							5	—	C	
28W/9419475	SP.15/C							5	—	C	
	10-20 TP 371							1	DTD.687	—	RE2
1699	10-20 TP 1479ND							1	DTD.687	C	
1654	DHS.358/2C							72	S.96	C	RE2
1655	DHS.358/3C							80	S.96	C	RE2
28M/10288	AGS.2001/C/1							152	—	C	
28W/9419404	SP.16/C							152	—	C	
12538	10-20 TP 739							1	DTD.687	C	RE2
1654	DHS.358/2C							94	S.96	C	RE2
1655	DHS.358/3C							80	S.96	C	RE2
28M/10328	AGS.2002/C/1							160	—	C	
28W/9419404	SP.16/C							152	—	C	
	10-20 TP 383A							2	—	—	RE1
1687	10-20 TP 1399A/ND							2	—	C	
28D/9133011	A25/2C							6	—	C	
26DL/7260	DHS.727/C16							6	—	C	RE1

TAIL UNIT
TAILPLANE, LESS ELEVATOR

Ref. No.	Part No.	Description	No. off	Material Specification	Class of Store or L.M.	Plate No.
	10-20 TP 4157A	RIB, shroud, adjacent to balance weights L.H., Port and Starboard, assembly (For spares use 10-20 TP 4377A/ND) (Mod. 1112)	2	—	—	RE1
17394	10-20 TP 4377A/ND	RIB, shroud, adjacent to balance weights L.H., Port and Starboard, assembly (Spares condition)	2	—	C	
	10-20 TP 4158A	RIB, shroud, adjacent to balance weights R.H., Port and Starboard, assembly (For spares use 10-20 TP 4378A/ND)	2	—	—	RE1
17395	10-20 TP 4378A/ND	RIB, shroud, adjacent to balance weights R.H., Port and Starboard, assembly (Spares condition)	2	—	C	
	10-20 TP 4161A	RIB, shroud end, Port, assembly (For spares use 10-20 TP 4381A/ND) (Mod. 1112)	1	—	—	RE1
17398	10-20 TP 4381A/ND	RIB, shroud end, Port, assembly (Spares condition)	1	—	C	
	10-20 TP 4162A	RIB, shroud end, Starboard, assembly (For spares use 10-20 TP 4382A/ND)	1	—	—	RE1
17399	10-20 TP 4382A/ND	RIB, shroud end, Starboard, assembly (Spares condition)	1	—	C	
	10-20 TP 4159A	RIB, shroud No. 1A, Port, assembly (For spares use 10-20 TP 4379A/ND) (Mod. 1112)	1	—	—	RE1
17396	10-20 TP 4379A/ND	RIB, shroud No. 1A, Port, assembly (Spares condition)	1	—	C	
	10-20 TP 4160A	RIB, shroud No. 1A, Starboard, assembly (For spares use 10-20 TP 4380A/ND) (Mod. 1112)	1	—	—	RE1
17397	10-20 TP 4380A/ND	RIB, shroud No. 1A, Starboard, assembly (Spares condition)	1	—	C	
	10-20 TP 4171A	RIB, shroud No. 2A, Port, assembly (For spares use 10-20 TP 4387A/ND) (Mod. 1112)	1	—	—	RE1
17403	10-20 TP 4387A/ND	RIB, shroud No. 2A, Port, assembly (Spares condition)	1	—	C	
	10-20 TP 4172A	RIB, shroud No. 2A, Starboard, assembly (For spares use 10-20 TP 4388A/ND) (Mod. 1112)	1	—	—	RE1
17404	10-20 TP 4388A/ND	RIB, shroud No. 2A, Starboard, assembly (Spares condition)	1	—	C	
	10-20 TP 4173A	RIB, shroud Nos. 3 and 6, Port, assembly (For spares use 10-20 TP 4389A/ND) (Mod. 1112)	2	—	—	RE1
17405	10-20 TP 4389A/ND	RIB, shroud Nos. 3 and 6, Port, assembly (Spares condition)	2	—	C	
	10-20 TP 4174A	RIB, shroud Nos. 3 and 6, Starboard, assembly (For spares use 10-20 TP 4390A/ND) (Mod. 1112)	2	—	—	RE1
17406	10-20 TP 4390A/ND	RIB, shroud Nos. 3 and 6, Starboard, assembly (Spares condition)	2	—	C	
	10-20 TP 4167A	RIB, shroud No. 4, L.H., Port and Starboard, and Port No. 7, assembly (For spares use 10-20 TP 4383A/ND) (Mod. 1112)	3	—	—	RE1

TAIL UNIT

TAIL PLANE, LESS ELEVATOR

Ref. No.	Part No.	Description						No. off	Material Specification	Class of Store or L.M.	Place No.
		1	2	3	4	5	6				
17400	10-20 TP 4383A/ND							3	—	C	
	10-20 TP 4168A							3	—	—	RE1
17401	10-20 TP 4384A/ND							3	—	C	
19323	10-20 TP 4097ND							1	—	C	RE5
19324	10-20 TP 4098ND							1	—	C	RE5
19327	10-20 TP 4177ND							1	—	C	RE6
19328	10-20 TP 4178ND							1	—	C	RE6
19329	10-20 TP 4181ND							1	—	C	RE6
19330	10-20 TP 4182ND							1	—	C	RE6
19331	10-20 TP 4185ND							1	—	C	RE6
19332	10-20 TP 4186ND							1	—	C	RE6
19333	10-20 TP 4195ND							1	—	C	RE6
19334	10-20 TP 4196ND							1	—	C	RE6
19335	10-20 TP 4201ND							1	—	C	RE6

TAIL UNIT

TAILPLANE, LESS ELEVATOR

Ref. No.	Part No.	Description						No. off	Material Specification	Class of Store or L.M.	Plate No.	
		1	2	3	4	5	6					
19336	10-20 TP 4202ND							1	—	C	RE6	
19322	10-20 TP 4091ND							1	—	C	RE5	
19321	10-20 TP 4087ND							1	—	C	RE5	
28D/9133011 28W/9419475	A25/2C SP.15/C							Bolt, 2 BA Washer	8 8	— —	C C	
	10-20 TP 4169A							RIB, shroud Nos. 4A, 5A and 6A, Port, assembly (For spares use 10-20 TP 4385A/ND) (Mod. 1112)	3	—	—	RE1
17402	10-20 TP 4385A/ND							RIB, shroud Nos. 4A, 5A and 6A, Port, assembly (Spares condition)	3	—	C	
	10-20 TP 4170A							RIB, shroud Nos. 4A, 5A and 6A, Starboard, assembly (For spares use 10-20 TP 4386A/ND) (Mod. 1112)	3	—	—	RE1
17407	10-20 TP 4386A/ND							RIB, shroud Nos. 4A, 5A and 6A, Starboard, assembly (Spares condition) Spares for 10-20 TP 4169A and 10-20 TP 4170A	3	—	C	
19323	10-20 TP 4097ND							ANGLE, reinforcing, aft (Mod. 1112)	1	—	C	RE5
19324	10-20 TP 4098ND							ANGLE, reinforcing, aft (Mod. 1112)	1	—	C	RE5
19331	10-20 TP 4185ND							ANGLE, reinforcing, bottom (Mod. 1112)	1	—	C	RE6
19332	10-20 TP 4186ND							ANGLE, reinforcing, bottom (Mod. 1112)	1	—	C	RE6
19322	10-20 TP 4091ND							ANGLE, reinforcing, centre (Mod. 1112)	1	—	C	RE5
19321	10-20 TP 4087ND							ANGLE, reinforcing, forward (Mod. 1112)	1	—	C	RE5
28D/9133011 28W/9419475	A25/2C SP.15/C							Bolt, 2 BA Washer	5 5	— —	C C	
	10-20 TP 377A							RIB, shroud No. 5, Port and Starboard, assembly (For spares use 10-20 TP 1403A/ND)	2	—	—	RE1

**TAIL UNIT
TAILPLANE, LESS ELEVATOR**

Ref. No.	Part No.	Description						No. off	Material Specification	Class of Store or L.M.	Plate No.
		1	2	3	4	5	6				
1692	10-20 TP 1403A/ND							2	—	C	
28D/9133011	A25/2C							6	—	C	
26DL/7260	DHS.727/C16							6	—	C	RE1
	10-20 TP 667A							1	—	—	RE2
14336	10-20 TP 855A/ND							1	—	P	
	10-20 TP 373A/1							1	—	—	RE2
14577	10-20 TP 841A/ND							1	—	P	
	10-20 TP 189A							1	—	—	RE1
28M/9993192	AGS.2009/C/1							78	—	C	
28M/10230	AGS.2009/E/1							10	—	C	
	10-20 TP 291ND							1	L.73	—	RE1
	10-20 TP 292ND							1	L.73	—	RE1
28D/9133011	A25/2C							2	—	C	
28M/1006473	A27/CT							2	—	C	
28W/9419404	SP.16/C							2	—	C	
	10-20 TP 289ND							2	L.73	—	RE1
	10-20 TP 1293ND							1	L.73	LM	RE2
	10-20 TP 1294ND							1	L.73	LM	RE2
	10-20 TP 1295ND							1	L.73	LM	RE2
	10-20 TP 1296ND							1	L.73	LM	RE2
	10-20 TP 1297ND							1	L.73	LM	RE2
	10-20 TP 1298ND							1	L.73	LM	RE2
	10-20 TP 1301ND							1	L.73	LM	RE2
	10-20 TP 1303ND							1	L.73	LM	RE2
	10-20 TP 293ND							4	L.73	LM	RE2
	10-20 TP 531ND							6	L.72	LM	RE2
28D/1011238	A25/3E							10	—	C	
28W/9418920	SP.10/E							10	—	C	

TAIL UNIT

TAILPLANE, LESS ELEVATOR

Ref. No.	Part No.	Description	No. off	Material Specification	Class of Store or L.M.	Plate No.
1790	DHS.726/C16	WASHER, support, skin attachments ...	22	DTD.746	C	RE2
1714	10 TP 1099	WASHER, packing, skin attachments ...	30	L.72	C	RE2
28W/9419475	SP.15/C	WASHER, skin attachments ...	16	—	C	
1714	10 TP 1099	WASHER, packing, skin attachments...	388	L.72	C	RE2
2A/9500467	HOFFMAN CA.3	Attachments for 10-20 TP 4211A, Tailplane :— Bearing, ball, elevator outboard hinge (No alternative) (Mod. 1399)	2	—	C	
28D/9133012	A25/3C	Bolt, 2 BA ...	4	—	C	
28D/1008151	A25/4E	Bolt, 1/8" BSF ...	20	—	C	
28D/13360	A30/7E	Bolt, 1/8" BSF ...	2	—	C	
28D/14245	A30/10J	Bolt, 3/8" BSF ...	2	—	C	
3234	DHS.365/4 1/2 G	Bolt, 1/8" BSF, bearing cap, fin head ...	8	—	C	RC3
26FC/11711	DHS.365/6G	Bolt, 1/8" BSF, bearing cap, fin head ...	8	—	C	RC3
2328	10 TE 759	Bolt, elevator outboard hinge ...	2	S.96	C	RB1
2301	10 CF 5091A	Bolt, 1/8" BSP, special, jackhead, assembly ...	2	—	P	RE4
2302	10 CF 5095	Adaptor, lubrication nipple ...	1	—	C	RE4
	10 CF 5093ND	Bolt, bare ...	1	S.96	—	RE4
28N/9156370	SP.21	Nipple, lubrication ...	1	—	C	RE4
2307	10 TP 1037A	Bolt, 3/8" BSF, special, crosshead, assembly ...	2	—	C	CB18
2314	10 TP 1355	Bolt, 3/8" BSF, special ...	2	S.96	C	RE4
1634	10 TF 1117	Bolt, 3/8" BSF, special, bearing cap, fin head ...	4	—	C	RE4
8335	10-20 TP 567A	Bridge, Port, assembly ...	1	—	C	RE2
8336	10-20 TP 568A	Bridge, Starboard, assembly ...	1	—	C	RE2
28M/13121	A27/CS	Nut, 2 BA ...	4	—	C	
28M/1011467	A27/ES	Nut, 1/8" BSF ...	17	—	C	
28M/13122	A27/GS	Nut, 1/8" BSF, bearing cap, fin head ...	16	—	C	
28M/1011476	A27/JS	Nut, 3/8" BSF ...	5	—	C	
28M/13259	A27/NS	Nut, 1/8" BSF ...	2	—	C	
28M/13275	A27/PC	Nut, 1/8" BSF ...	4	—	C	
28M/14833	A58/JS	Nut, 3/8" BSF ...	2	—	C	
28P/1007741	SP.9/C8	Pin, split ...	44	—	C	
28P/9429652	SP.9/E10	Pin, splic ...	2	—	C	
2303	10 CF 5087	Roller ...	2	S.106	C	RE4
2324	10-20 TE 135	Roller ...	2	DTD.197	C	RE4
26DV/6604	DHS.69/FF	Shim, elevator outboard, hinge Starboard ...	3	LB.2	C	RB1
28W/9419475	SP.15/C	Washer ...	4	—	C	
28W/9419476	SP.15/G	Washer, bearing cap, fin head ...	16	—	C	
28W/9419477	SP.15/J	Washer ...	4	—	C	
28W/9419479	SP.15/N	Washer ...	2	—	C	
28W/9419487	SP.16/E	Washer ...	2	—	C	
28W/9419489	SP.16/J	Washer, bearing cap, fin head ...	2	—	C	
28W/9419492	SP.16/P	Washer ...	4	—	C	

TAIL UNIT
TAILPLANE, LESS ELEVATOR

Ref. No.	Part No.	Description						No. off	Material Specification	Class of Score or L.M.	Plate No.
		1	2	3	4	5	6				

RE.1

SEE TEXT FOR SPARES CONDITION
OF ITEMS MARKED THUS: *

- *TOP FRONT SKIN IO.20 TP 1273A
- *BOTTOM FRONT SKIN IO.20 TP 557A/I
- *TOP REAR SKIN IO.20 TP 53A/I
- *BOTTOM REAR SKIN IO.20 TP 549A
- *LEADING EDGE SKIN IO.20 TP 4199A
- DHS. 358/2C
- DHS. 365/2C
- DHS. 365/2CC

- * IO.20 TP 4169A L.H.
- * IO.20 TP 4170A R.H.

- * IO.20 TP 4167A L.H.
- * IO.20 TP 4168A R.H.

- * IO.20 TP 4171A L.H.
- * IO.20 TP 4172A R.H.

- * IO.20 TP 383A
- DHS.727/C 16

- * IO.20 TP 892A

SPAR, FRONT.
IO.20 TP 175A
IO.20 TP 203ND (BARE)
DHS 365/2E BOLT

SPAR, REAR.
IO.20 TP 189A
IO.20 TP 291ND
IO.20 TP 292ND
PLATE, END.
IO.20 TP 289ND
PLATE, INNER.

- * IO.20 TP 377A
- DHS.727/C 16
WASHER

- * IO.20 TP 4173A L.H.
- * IO.20 TP 4174A R.H.

- * IO.20 TP 4159A L.H.
- * IO.20 TP 5160A R.H.

NOSE RIBS 1 to 6 L.H. & R.H.
* IO.20 TP 4163A

SKIN, LEADING EDGE, ASSY
* IO.20 TP 4199A

NOSE RIB No.7
* IO.20 TP 4165A

IO.20 TP 195ND STRINGER
DHS.358/2C BOLT

- * IO.20 TP 4155A L.H.
- * IO.20 TP 4156A R.H.
- IOCF 5371

- * IO.20 TP 4151A L.H.
- * IO.20 TP 4152A R.H.

- * IO.20 TP 4157A

- * IO.20 TP 4158A



MAKE FROM
STANDARD SECTION
J 255

- * IO.20 TP 4153A L.H.
- * IO.20 TP 4154A R.H.
- IOCF 5371

IO.20 TP 4387
IO.20 TP 4119

ATTACHMENTS FOR
RIBS 3,4,5 AND 6

- * IO.20 TP 4149A L.H.
- * IO.20 TP 4150A R.H.
- IO.20 TP 1357
- IO.20 TP 1571
- IO.20 TP 1529
- IOCF 5371
- DHS.358/2C

- * IO.20 TP 4147A L.H.
- * IO.20 TP 4148A R.H.

- * IO.20 TP 4145A L.H.
- * IO.20 TP 4146A R.H.
- IOCF 5371 FAIRLEAD

- * IO.20 TP 891A
- DHS 358/3C BOLT
- DHS 365/3 E
- DHS 365/4 E
- DHS 365/5 E
- DHS 365/6 E
- DHS 365/8 E
- DHS 180 MK 1/X
- DHS.727/C 16 WASHER

DHS 358/2C BOLT
DHS 358/3C BOLT
IO TP 1099 WASHER
IOCF 5371 FAIRLEAD

ATTACHMENTS FOR RIBS 1 AND 2

TAILPLANE, LESS ELEVATOR, SPARES ASSY
C/W ATTACHMENTS S IO.20 TP 8

ASSEMBLY IO.20 TP 4211A
STRUCTURE IO.20 TP 4187A

TAIL UNIT

TAILPLANE, LESS ELEVATOR, COMPLETE

RESTRICTED

RE.1
[1.42]

See Vixen Mk.1

RESTRICTED

Plate RE.1

RE.2

TAIL UNIT
TAIL PLANE, LESS ELEVATOR.

RESTRICTED

RE.2
D.L. 543

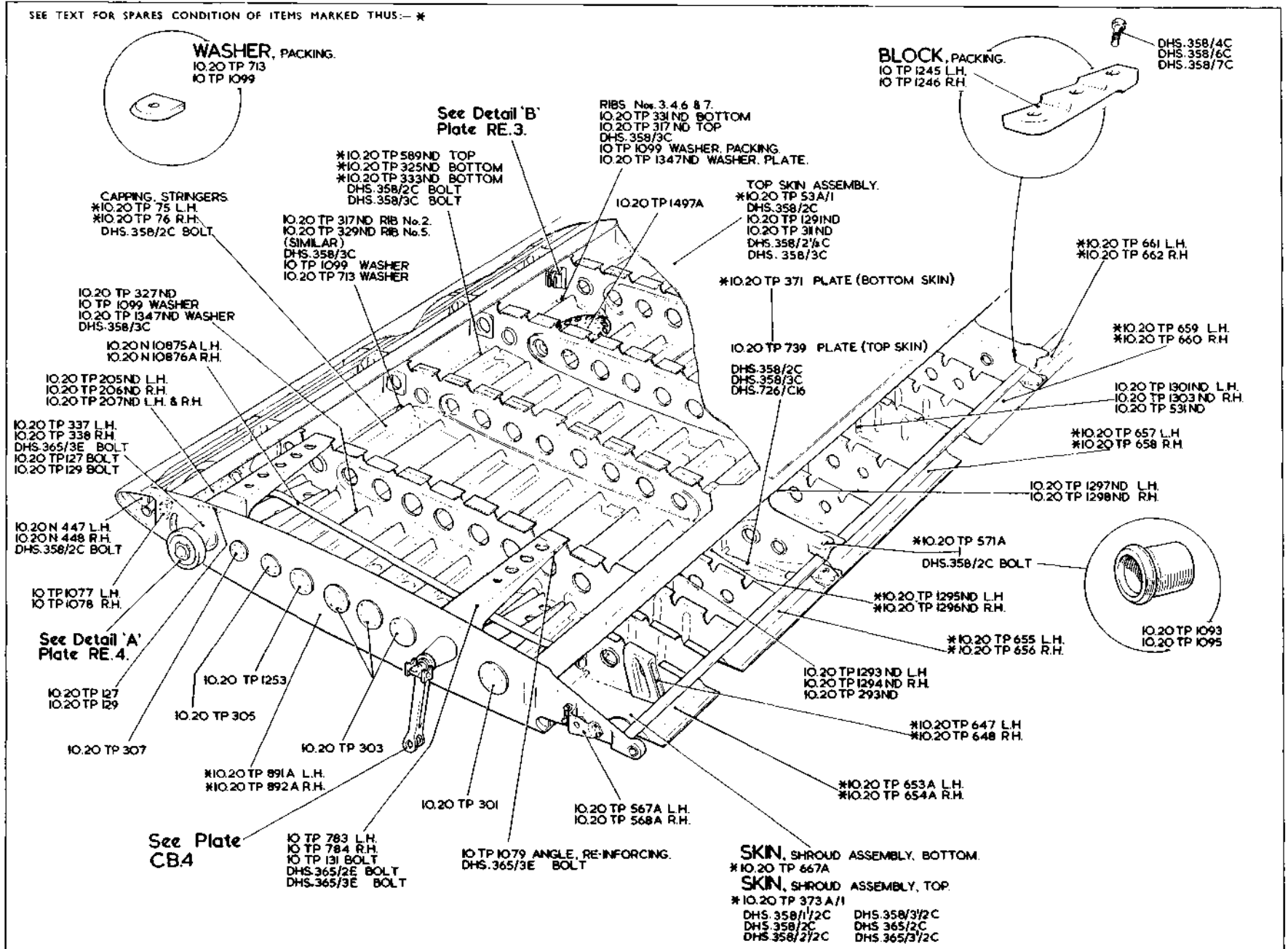

See Vixen Mk.1

RESTRICTED

Plate RE2

SEE TEXT FOR SPARES CONDITION OF ITEMS MARKED THUS: *

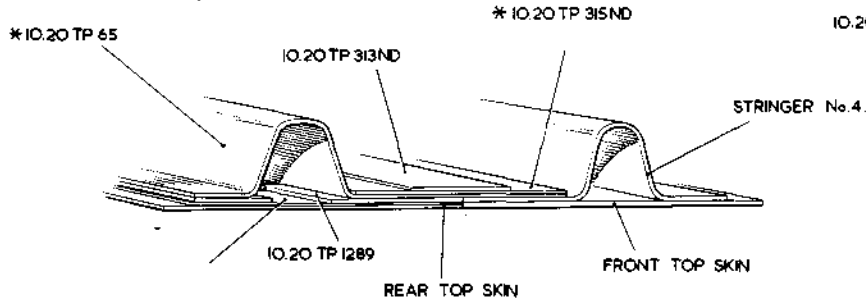

SECTION THROUGH TOP SKIN AT RIB No. 3.

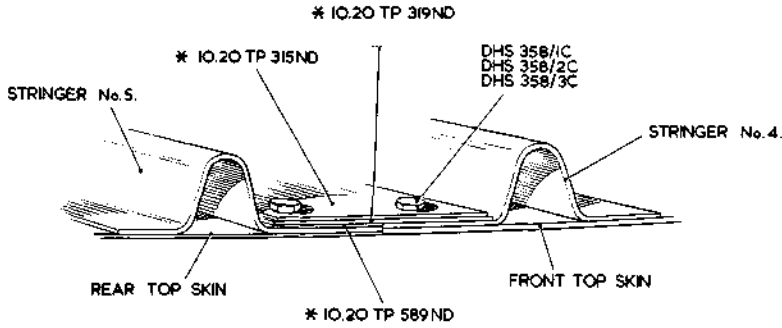

SECTION THROUGH TOP SKIN BETWEEN RIBS Nos 3 & 4

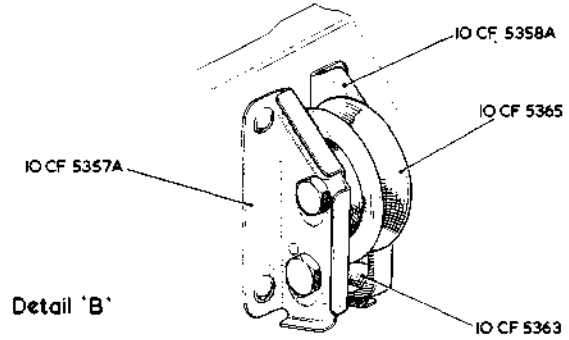

Detail 'B'

BRACKET, PULLEY & BOBBIN. RIB No. 4.

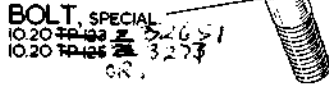

- CAPPING, STRINGERS.
TOP SKIN
* IO.20 TP 43
* IO.20 TP 45
* IO.20 TP 321
BOTTOM SKIN
* IO.20 TP 591
DHS.358/2C

MAKE FROM J2102 SECTION, AS BELOW.

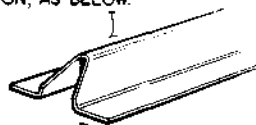

- CAPPING, STRINGERS.
* IO.20 TP 47 L.H.
* IO.20 TP 48 R.H.
* IO.20 TP 65 L.H.
* IO.20 TP 66 R.H.
DHS.358/2C

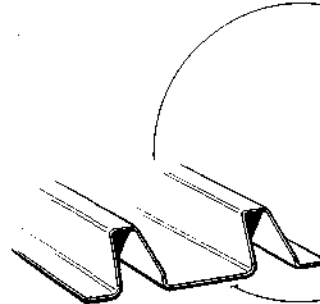

SEE TEXT FOR SPARES CONDITION OF ITEMS MARKED THUS: *

AL 50
AL 211A
ATTACHMENTS FOR IO.20 TP ~~9989~~ TAILPLANE :-

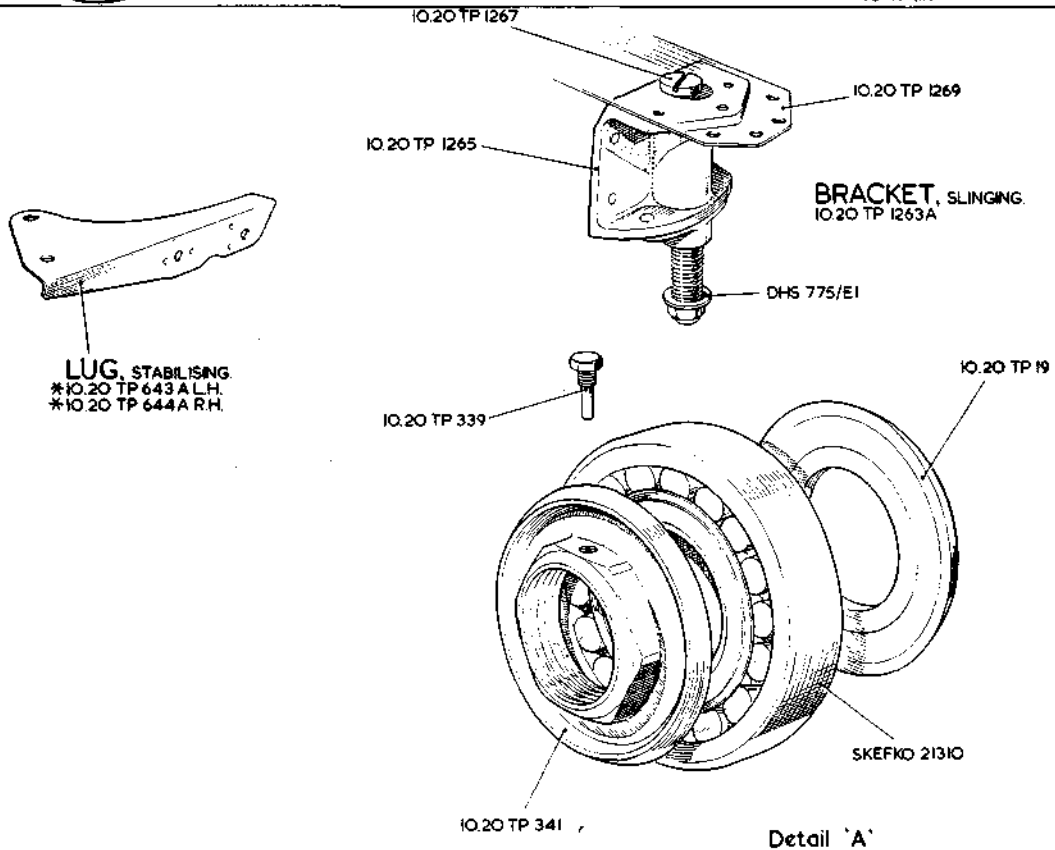
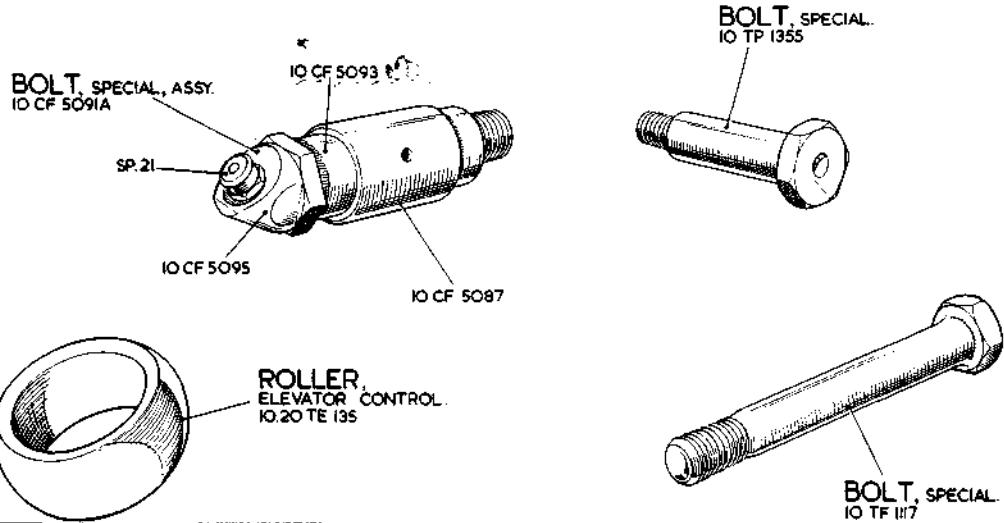

RE.4

TAIL UNIT

RE.4

TAILPLANE, LESS ELEVATOR

[AL.34]

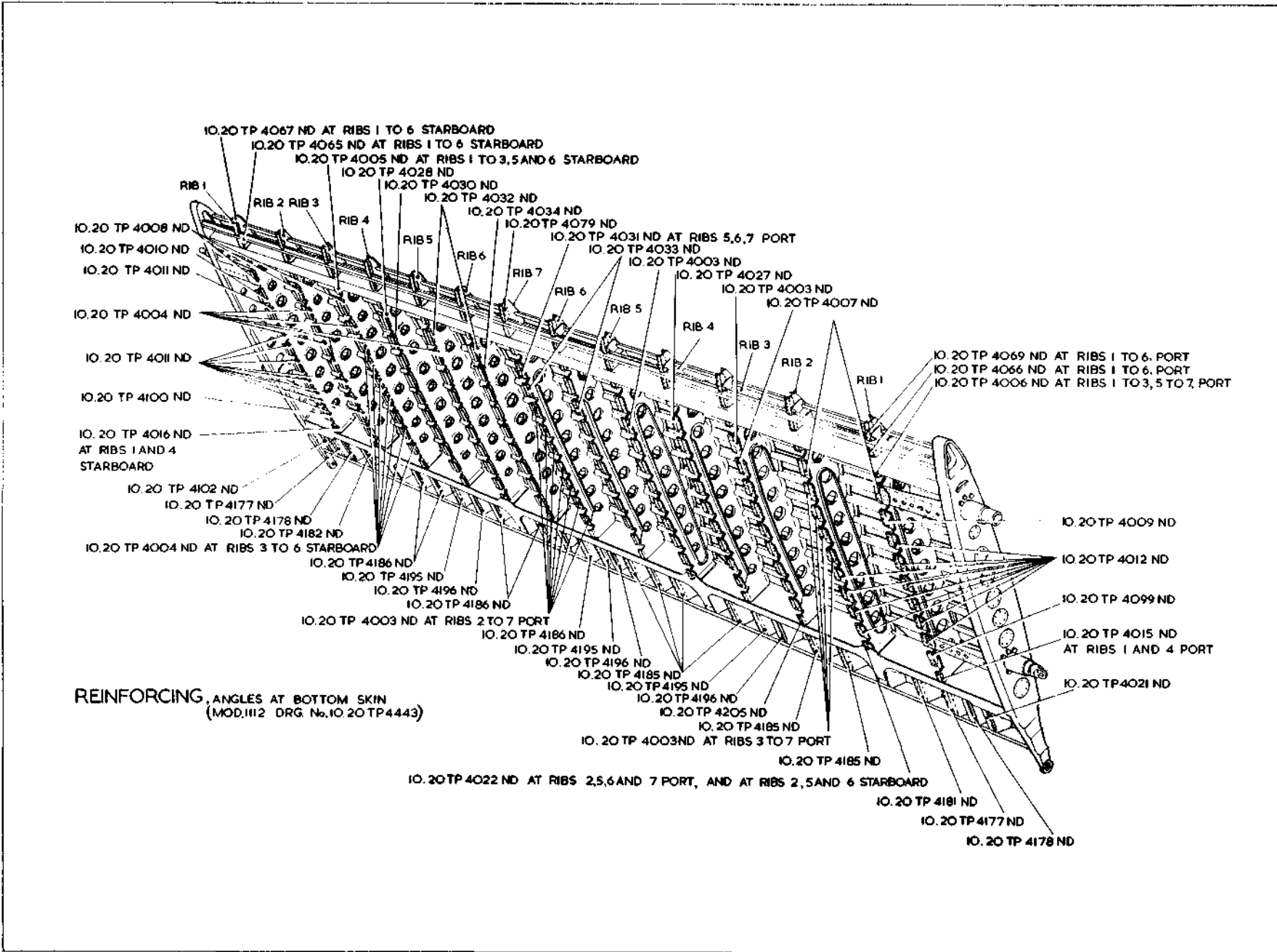

RE 6

TAIL UNIT
TAILPLANE LESS ELEVATOR

RESTRICTED

RE 6

[Pl. 60]

This file was downloaded
from the RTFM Library.

Link: www.scottbouch.com/rtfm

Please see site for usage terms,
and more aircraft documents.

**TELEBRIEF
CONNECTIONS**

E

