

DOOR LOCK OPERATING MECHANISM, MAIN UNDERCARRIAGE

Ref. No.	Part No.	Description	No. off	Material Specification	Class of Score or L.M	Plate No.
	—	INSTALLATION OF DOOR LOCK OPERATING MECHANISM (Drg. No. 10-20 U 19)	2	—	—	SE1
1966	10-20 U 725	ARM , striker, door lock micro-switch	1	—	C	SE1
		Attachments for 10-20 U 725, Arm :—				
28D/9140645	A25/10C	Bolt, 2 BA	1	—	C	
28M/5808573	A27/CS	Nut, 2 BA	2	—	C	
28P/9527619	SP.90/C7	Pin, split (SP.9/C8)	1	—	C	
	AS.2808/5/076	Tube, distance, $\frac{3}{8}$ " o/d x 17 SWG x 0"-76 long	1	T.35	LM	
28W/9419475	SP.15/C	Washer	1	—	C	
2043	DHS.826/C/90	BOLT , striker, door, lock micro-switch	1	—	C	SE1
		Attachments for DHS.826/C/90, Bolt :—				
28M/1006473	A27/CT	Nut, 2 BA	1	—	C	
2981	10-20 U 1025	BRACKET , mounting, aft hook pivot, Port	1	—	C	SE1
2982	10-20 U 1026	BRACKET , mounting, aft hook pivot, Starboard	1	—	C	SE1
		Attachments for 10-20 U 1025 or 10-20 U 1026, Bracket :—				
28D/1008151	A25/4E	Bolt, $\frac{1}{2}$ " BSF	4	—	C	
28D/1200119	A25/4C	Bolt, 2 BA	1	—	C	
28M/1007403	A27/ET	Nut, $\frac{1}{2}$ " BSF	4	—	C	
28M/1006473	A27/CT	Nut, 2 BA	1	—	C	
8362	10-20 U 1377A	HOOK , aft, assembly	1	—	C	SE1
1992	10-20 U 733A	HOOK , inboard, assembly	1	—	C	SE1
		Spares for :—				
2A/9501471	SKEFKO 401458	BEARING , ball (3110-99-950-1471)	1	—	C	SE1
		Attachments for 10-20 U 1377A or 10-20 U 733A, Hook :—				
28M/14833	A58/JS	Nut, $\frac{3}{4}$ " BSF	1	—	C	
28P/9527619	SP.90/C7	Pin, split (SP.9/C8)	1	—	C	
28W/9419477	SP.15/J	Washer	1	—	C	
9529	10-20 U 1647	Washer, aft hook, only, inner face, Starboard	1	—	C	SE1
14050	10-20 U 1893	Washer, aft hook only, outer face, Port	1	—	C	SE1
9532	DHS.781/49/20	Washer, inboard hook only, inner face, Starboard	1	—	C	SE1
9528	DHS.781/46/20	Washer, inboard hook, only, outer face, Port	1	—	C	SE1
	10-20 U 707A	HOOK , outboard, Port, assembly	1	—	—	SE1
	10-20 U 708A	HOOK , outboard, Starboard, assembly	1	—	—	SE1
19515	HOFFMANN N.8898	BEARING , ball	1	—	C	SE1
		Attachments for HOFFMANN N.8898, Bearing :—				
28N/2001690	AGS.2030/37	Circlip	1	—	C	
28D/1013173	AS.1242/10C	BOLT , 2 BA, pivot, cam	1	—	C	
28D/9140645	A25/10C	BOLT , 2 BA, pivot, micro-switch lever	1	—	C	
		Attachments for A25/10C, Bolt :—				
28M/1006473	A27/CT	Nut, 2 BA	1	—	C	
28W/9419454	SP.10/C	Washer	1	—	C	
2979	10-20 U 1021	BUSH , lever bearing	1	—	C	SE1
1967	10-20 U 721	CAM , operating micro-switch striker lever	1	—	C	SE1
1971	10-20 U 709	HOOK , bare	1	—	C	SE1
	10-20 U 711A	LEVER , L.H., assembly	1	—	—	SE1
	10-20 U 712A	LEVER , R.H., assembly	1	—	—	SE1
		Spares for :—				
19515	HOFFMANN N.8898	BEARING , ball	1	—	C	SE1
3034	10-20 U 623	BUSH (See Repair section PA)	1	—	C	SE1

UNDERCARRIAGE

DOOR LOCK OPERATING MECHANISM, MAIN UNDERCARRIAGE

Ref. No.	Part No.	Description	No. off	Material Specification	Class of Store or L.M	Plate No.
1970	10-20 U 717	LEVER , micro-switch...	1	—	C	SE1
1968	10-20 U 719	LINK , between cam and lever	1	—	C	SE1
28P/831	SP.4Y/B5	Attachments for 10-20 U 719, Link :—				
28P/9527619	SP.90/C7	Pin, shackle	2	—	C	
28W/9419475	SP.15/C	Pin, split (SP.9/C8)	2	—	C	
		Washer	2	—	C	
	10-20 U 723	TUBE , distance, cam and micro-switch lever pivot, 1/4" o/d x 22 SWG x 0"-249 long	2	T.35	LM	SE1
		Attachments for 10-20 U 707A or 10-20 U 708A, Hook :—				
2980	10-20 U 1019	Bolt, pivot	1	—	C	SE1
28M/14537	A58/GS	Nut, 5/16" BSF	1	—	C	
28P/9527619	SP.90/C7	Pin, split (SP.9/C8)	1	—	C	
28W/9419455	SP.10/G	Washer	1	—	C	
19486	10-20 U 4045A	LEVER , aft hook connecting rod, at Rib No. 2, assembly (Mod. 1350)	1	—	P	SE1
		Spares for :—				
19515	HOFFMANN N.8898	BEARING , ball	2	—	C	SE2
	DHS.418/1/E"-17	BUSH	4	DTD.197	—	SE2
1991	10-20 U 643	TUBE , distance	1	—	C	SE2
		Attachments for 10-20 U 4045A, Lever :—				
28D/9435058	A59/17J	Bolt, 3/8" BSF	1	—	C	
28M/14833	A58/JS	Nut, 3/8" BSF	1	—	C	
28P/9527619	SP.90/C7	Pin, split (SP.9/C8)	1	—	C	
28W/9419477	SP.15/J	Washer	1	—	C	
19487	10-20 U 4047A	LEVER , aft hook connecting rod, at rib No. 3, Port, assembly (Mod. 1350)	1	—	P	SE1 SE2
19488	10-20 U 4048A	LEVER , aft hook connecting rod, at rib No. 3, Star- board assembly (Mod. 1350)	1	—	P	SE2
		Spares for :—				
19515	HOFFMANN N.8898	BEARING , ball	2	—	C	SE2
2045	DHS.419/2/E"-18	BUSH , plain (See Repair section PA)	2	—	C	SE2
1996	10-20 U 547	BUSH , threaded	2	—	C	SE2
		Attachments for 10-20 U 547, Bush :—				
28S/9419438	A33/B10	Screw, 4 BA	1	—	C	
13577	10-20 U 1851	SPACER	1	—	C	SE2
		Attachments for 10-20 U 4047A or 10-20 U 4048A, Lever :—				
12257	10-20 U 1799	Bolt, special	1	—	C	SE1
13574	10-20 U 1849	Spacer	1	—	C	SE1
28W/9419466	SP.13/J	Washer	1	—	C	
14360	DHS.781/15/26	Washer, shim	3	—	C	SE1
19485	10-20 U 4049A	LEVER , outboard hook connecting rod, at rib No. 3, assembly (Mod. 1350)	1	—	P	SE1
		Spares for :—				
19515	HOFFMANN N.8898	BEARING , ball	2	—	C	SE1
3034	10-20 U 623	BUSH , shouldered (See Repair section PA)	4	—	C	SE1
1965	10-20 U 641	TUBE , distance	1	—	C	SE1
		Attachments for 10-20 U 4049A, Lever :—				
28D/9435058	A59/17J	Bolt, 3/8" BSF	1	—	C	
28M/14833	A58/JS	Nut, 3/8" BSF	1	—	C	
28P/9527619	SP.90/C7	Pin, split (SP.9/C8)	1	—	C	
28W/9419477	SP.15/J	Washer	1	—	C	

UNDERCARRIAGE

DOOR LOCK OPERATING MECHANISM, MAIN UNDERCARRIAGE

Ref. No.	Part No.	Description	No. off	Material Specification	Class of Score or L.M.	Plate No.
2983	10-20 U 1023	PIVOT , aft hook	1	—	C	SE1
		Attachments for 10-20 U 1023, Pivot :—				
2374	10-20 U 537	Locknut, $\frac{3}{8}$ " whit. x 20 T.P.I.	1	—	C	SE1
28P/9527619	SP.90/C7	Pin, split (SP.9/C8)	1	—	C	SE1
2984	10-20 U 1043	Washer	1	—	C	SE1
19489	10-20 U 2005A	ROD , connecting, aft hook, assembly (Mod. 1350) ...	1	—	P	SE1
		Attachments for 10-20 U 2005A, Rod :—				
5619	A59/7E/DHS.514/D	Bolt, $\frac{1}{4}$ " BSF	1	—	C	SE1
1977	10-20 U 645	Bolt, hollow, tapped 2 BA	1	—	C	SE1
28P/9527619	SP.90/C7	Pin, split (SP.9/C8)	1	—	C	SE1
19495	10-20 U 2025A	ROD , connecting, between aft hook and lever on rear wheel well wall, assembly (Mod. 1350)	1	—	P	SE1
		Spares for :—				
19496	10-20 U 2027A	ADJUSTER , end, assembly	1	—	P	SE1
	10-20 U 1145	ANCHOR , spring, 18 SWG	1	S.510	LM	SE1
		Attachments for 10-20 U 1145, Anchor :—				
28D/1009984	A25/7B	Bolt, 4 BA	2	—	C	SE1
28M/9406519	A27/BP	Nut, 4 BA	2	—	C	SE1
	10-20 U 1147	Washer, saddle	4	L.64	LM	SE1
3758	10-20 U 1169	BARREL , adjuster	1	—	C	SE1
	OR					
	10-20 U 1957	BARREL , adjuster	1	L.64	—	SE1
28M/13464	A27/GTL	NUT , $\frac{5}{16}$ " BSF, L.H.	1	—	C	SE1
28M/1011470	A27/GT	NUT , $\frac{5}{16}$ " BSF, R.H.	1	—	C	SE1
		Attachments for 10-20 U 2025A, Rod :—				
1978	10-20 U 647	Bolt, 2 BA, special	1	—	C	SE1
28D/1215686	A59/7E	Bolt, $\frac{1}{4}$ " BSF	1	—	C	SE1
1977	10-20 U 645	Bolt, hollow, tapped 2 BA	1	—	C	SE1
28M/13935	A58/ES	Nut, $\frac{1}{4}$ " BSF	1	—	C	SE1
28P/9527619	SP.90/C7	Pin, split (SP.9/C8)	2	—	C	SE1
28W/9419405	SP.15/E	Washer	1	—	C	SE1
19492	10-20 U 2021A	ROD , connecting, inboard hook, assembly (Mod. 1350)	1	—	P	SE1
		Spares for :—				
	10-20 U 1145	ANCHOR , spring, 18 SWG	1	S.510	LM	SE1
		Attachments for 10-20 U 1145, Anchor :—				
28D/1011011	A25/8B	Bolt, 4 BA	2	—	C	SE1
28M/9403519	A27/BP	Nut, 4 BA	2	—	C	SE1
	10-20 U 1147	Washer, saddle	4	L.64	LM	SE1

UNDERCARRIAGE

DOOR LOCK OPERATING MECHANISM, MAIN UNDERCARRIAGE

Ref. No.	Part No.	Description	No. off						Material Specification	Class of Store or LM	Place No.
			1	2	3	4	5	6			
1975	10-20 U 697	BARREL , adjustable	1						C	SE1	
19494	10-20 U 2019A	EYE-END , adjustable	1						C	SE1	
28M/13811	A27/JTL	NUT , $\frac{3}{8}$ " BSF, L.H.	1						C		
28M/1007404	A27/JT	NUT , $\frac{3}{8}$ " BSF, R.H.	1						C		
	10-20 U 705	PLUG-END , screwed	1					S.96	—	SE1	
		Attachments for 10-20 U 705, Plug-end :—									
26DV/7618	DHS.94/4/80	Pin, ground steel, $\frac{1}{8}$ " dia.	3						C	SE1	
		Attachments for 10-20 U 2021A, Rod :—									
28D/1215686	A59/7E	Bolt, $\frac{1}{2}$ " BSF	1						C		
28D/1213591	A59/11E	Bolt, $\frac{1}{2}$ " BSF	1						C		
28M/13935	A58/ES	Nut, $\frac{1}{2}$ " BSF	2						C		
28P/5210	AGS.1551/1	Pin, locking	1						C		
28P/9527619	SP.90/C7	Pin, split (SP.9/C8)	1						C		
28W/9419405	SP.15/E	Washer	2						C		
19493	10-20 U 2017A	ROD , connecting, between outboard hook and lever at rib No. 3, assembly (Mod. 1350)	1						P	SE1 SE2	
		Spares for :—									
1975	10-20 U 697	BARREL , adjustable	1						C	SE2	
19494	10-20 U 2019A	EYE-END , adjustable	1						C	SE2	
28M/13811	A27/JTL	NUT , $\frac{3}{8}$ " BSF, L.H. thread	1						C		
28M/1007404	A27/JT	NUT , $\frac{3}{8}$ " BSF, R.H.	1						C		
	10-20 U 699	PLUG-END , screwed	1					S.96	—	SE2	
		Attachments for 10-20 U 699, Plug-end :—									
2044	DHS.94/4/65	Pin, ground steel, $\frac{1}{8}$ " dia.	3						C	SE2	
		Attachments for 10-20 U 2017A, Rod :—									
28D/1215686	A59/7E	Bolt, $\frac{1}{2}$ " BSF	1						C		
28D/1213591	A59/11E	Bolt, $\frac{1}{2}$ " BSF	1						C		
28M/13935	A58/ES	Nut, $\frac{1}{2}$ " BSF	1						C		
28P/9527619	SP.90/C7	Pin, split (SP.9/C8)	2						C		
28W/9019405	SP.15/E	Washer	2						C		
19491	10-20 U 2013A	ROD , connecting, torque tube and lever at rib No. 3, assembly (Mod. 1350)	1						P	SE1 SE2	
		Spares for :—									
		Attachments for 10-20 U 2013A, Rod :—									
5619	A59/7E/DHS.514/D	Bolt, $\frac{1}{2}$ " BSF (Alternative S21/A59/7E)	1						C	SE1	
28D/1213591	A59/11E	Bolt, $\frac{1}{2}$ " BSF	1						C		
28M/13935	A58/ES	Nut, $\frac{1}{2}$ " BSF	1						C		
28P/9527619	SP.90/C7	Pin, split (SP.9/C8)	1						C		

DOOR LOCK OPERATING MECHANISM, MAIN UNDERCARRIAGE

Ref. No.	Part No.	Description	No. off	Material Specification	Class of Store or L.M	Place No.
19490	10-20 U 2011A	ROD , connecting torque tubed outboard hook lever, assembly (Mod. 1350)	1	—	P	SE1
28D/1213591	A59/11E	Attachments for 10-20 U 2011A, Rod :—				
28M/13935	A58/ES	Bolt, 1/4" BSF	2	—	C	
28P/9527619	SP.90/C7	Nut, 1/4" BSF	2	—	C	
28W/9419405	SP.15/E	Pin, split (SP.9/C8)	2	—	C	
		Washer	2	—	C	
3759	10-20 U 1149	SPRING , hook return	4	—	C	SE1
19497	10-20 U 2049A	STRUT , spring, between torque tube and main spar, assembly (Mod. 1350)	1	—	P	SE1
		Spare for :—				
19498	10-20 U 2051A	EYE-END , adjustable	1	—	C	SE2
28M/1007404	A27/JT	NUT , 3/8" BSF	1	—	C	
2019	10-20 U 755	NUT , sliding tube retaining	1	—	C	SE2
2018	10-20 U 757	SPRING , compression	1	—	C	SE2
2017	10-20 U 745	TUBE , sliding, inner	1	—	C	SE2
28W/9419466	SP.13/J	WASHER (To be filed to fit a radius inside sliding tube)	1	—	C	
2020	10-20 U 761	WASHER , in outer barrel	1	—	C	SE2
		Attachments for 10-20 U 2049A, Strut :—				
28D/1010030	A25/7C	Bolt, 2 BA	2	—	C	
28M/5808573	A27/CS	Nut, 2 BA	2	—	C	
28P/9527619	SP.90/C7	Pin, split (SP.9/C8)	2	—	C	
28W/9419475	SP.15/C	Washer	2	—	C	
19499	10-20 U 2071A	STRUT , telescopic, between torque tube and lever on undercarriage leg, assembly (Mod. 1350)	1	—	P	SE1
28N/2001666	AGS.2031/1	CIRCLIP	1	—	C	
19501	10-20 U 2075A	EYE-END , adjustable	1	—	C	SE2
19500	10-20 U 2073A	EYE-END , fixed	1	—	C	SE2
9526	10-20 U 1617	NUT	1	—	C	SE2
9522	10-20 U 1609	ROD , sliding	1	—	C	SE2
9523	10-20 U 1611	SHEATH , inner	1	—	C	SE2
9524	10-20 U 1613	SHEATH , middle	1	—	C	SE2
9525	10-20 U 1615	SHEATH , outer	1	—	C	SE2
		Attachments for 10-20 U 2071A, Strut :—				
28D/1213590	A59/10E	Bolt, 1/4" BSF	1	—	C	
28D/1213591	A59/11E	Bolt, 1/4" BSF	1	—	C	
28M/13935	A58/ES	Nut, 1/4" BSF	2	—	C	
28P/9527619	SP.90/C7	Pin, split (SP.9/C8)	2	—	C	
28W/9419405	SP.15/E	Washer	2	—	C	
19502	10-20 U 2057A	STRUT , telescopic, between undercarriage torque tube and side stay, assembly (Mod. 1350)	1	—	P	SE1 SE4
1987	10-20 U 247	ADJUSTER	1	—	C	SE2
	10-20 U 2061A	BARREL , outer	1	—	—	SE2
	10-20 U 2059A	EYE-END	1	—	—	SE2

MAIN UNDERCARRIAGE

DOOR LOCK OPERATING MECHANISM, MAIN UNDERCARRIAGE

Ref. No.	Part No.	Description	No off						Material Specification	Class of Store or L.M	Place No.
			1	2	3	4	5	6			
1988	10-20 U 245	NUT						1	—	C	SE2
5563	10-20 U 1337	ROD , sliding						1	—	C	SE2
		Attachments for 10-20 U 2057A, Strut :—									
28D/1212211	A57/11E	Bolt, 1/2" BSF						1	—	C	
28D/1215687	A59/8E	Bolt, 1/2" BSF						1	—	C	
28D/1213591	A59/11E	Bolt, 1/2" BSF						1	—	C	
28M/13935	A58/ES	Nut, 1/2" BSF						3	—	C	
28P/9527619	SP.90/C7	Pin, split (SP.9/C8)						3	—	C	
28W/9419405	SP.15/E	Washer						3	—	C	
8365	10-20 U 1365A	TUBE , torque, Port, assembly						1	—	P	SE1
8366	10-20 U 1366A	TUBE , torque, Starboard, assembly						1	—	P	SE1
8367	10-20 U 1359A	LEVER , aft, Port, assembly						1	—	C	SE1
8368	10-20 U 1360A	LEVER , aft, Starboard, assembly						1	—	C	SE1
		Spares for :—									
8369	10-20 U 1363	BUSH } (See Repair section PA)						2	—	C	SE1
3034	10-20 U 623	BUSH } (See Repair section PA)						4	—	C	SE1
		Attachments for 10-20 U 1359A or 10-20 U 1360A, Lever :—									
19169	DHS.94/8/180	Pin, ground steel, 1/2" dia.						6	—	C	SE1
2010	10-20 U 771A	LEVER , forward, L.H., assembly						1	—	C	SE1
2011	10-20 U 772A	LEVER , forward, R.H., assembly						1	—	C	SE1
		Spares for :—									
3034	10-20 U 623	BUSH (See Repair Section PA)						4	—	C	SE1
		Attachments for 10-20 U 771A or 10-20 U 772A, Lever :—									
28D/7002440	A25/18E	Bolt, 1/2" BSF } Fit on assembly (See Drg. No.						1	—	C	
28M/13935	A58/ES	Nut, 1/2" BSF } 10-20 U 19)						1	—	C	
19169	DHS.94/8/180	Pin, ground steel, 1/2" dia.						3	—	C	SE1
28P/9527619	SP.90/C7	Pin, split (SP.9/C8) } Fit on assembly (See Drg.						1	—	C	
28W/9418921	SP.13/E	Washer } No. 10-20 U 19)						1	—	C	
2014	10-20 U 663	SPIGOT , fixed						1	—	C	SE1
		Attachments for 10-20 U 663, Spigot :—									
26FC/4643	DHS.94/6/140	Pin, ground steel, 3/8" dia.						1	—	C	SE1
2009	10-20 U 661	SPIGOT , sliding						1	—	C	SE1
		Attachments for 10-20 U 1365A or 10-20 U 1366A, Tube :—									
28D/7002440	A25/18E	Bolt, 1/2" BSF						1	—	C	
28M/13935	A58/ES	Nut, 1/2" BSF						1	—	C	
28P/9527619	SP.90/C7	Pin, split (SP.9/C8)						1	—	C	
28W/9418921	SP.13/E	Washer						1	—	C	
28W/9419458	SP.10/N	Washer (if required -max. 2 off)						2	—	C	
28W/9419468	SP.13/N	Washer (if required -max. 1 off)						1	—	C	

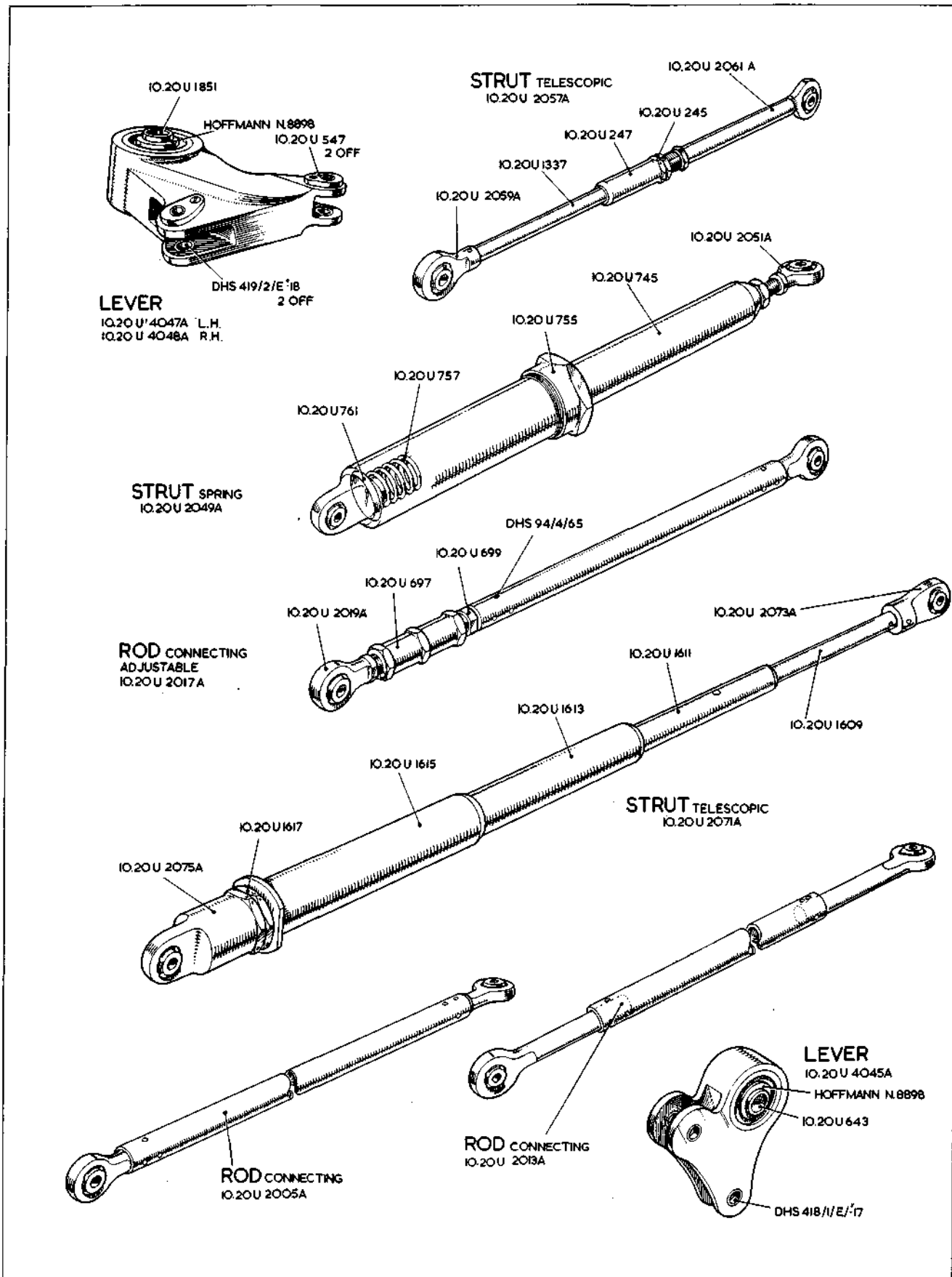

SE.2

UNDERCARRIAGE
DOOR LOCK OPERATING MECHANISM
MAIN UNDERCARRIAGE

SE.2

[A.L. 63]

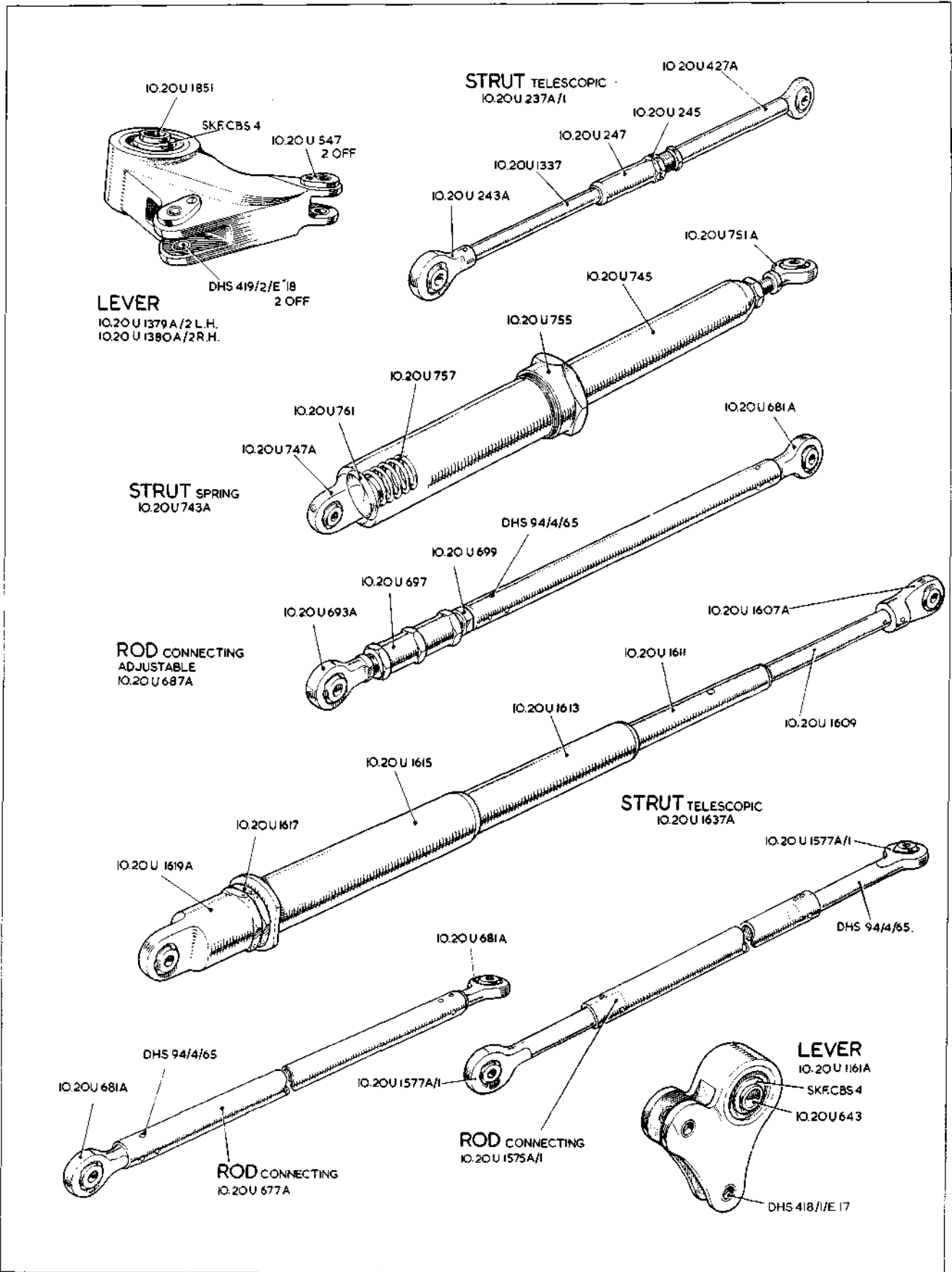

SE.2

UNDERCARRIAGE
DOOR LOCK OPERATING MECHANISM
MAIN UNDERCARRIAGE

SE.2

[A.L.21]



This file was downloaded
from the RTFM Library.

Link: www.scottbouch.com/rtfm

Please see site for usage terms,
and more aircraft documents.