

Chapter 12

PITOT-STATIC TRANSDUCER, TYPE B, Ref. No. 6A/6435

and

MOUNTING TRAY, TYPE B, Ref. No. 6A/5937

LIST OF CONTENTS

	Para.		Para.
General description	1	Motor-tachogenerator	32
Summary of operation	10	Outputs from servo system	35
Pitot-static capsule unit		Transmitter synchro	36
Description		Potentiometer RV3	39
General	13	Gear train	
Capsule	15	General	40
Heater circuit	16	Split gears	43
Principle of operation	18	Slip clutch	44
Servo system		Gear stop	45
Servo amplifier	21	Adjustable cam	47
Transistor amplifier	22	Cam unit CU8	50
Demodulator	24	Servicing	52
Magnetic amplifier	27	Mounting tray, Type B	53
Inputs to servo amplifier	31		

LIST OF TABLES

	Tables		Tables
Power supplies	1	Connections to socket PT1 and plug PT2	3
Outputs	2	Component values	4

LIST OF ILLUSTRATIONS

	Fig.		Fig.
Pitot-static transducer, Type B	1	Rear view of transducer	7
Interior of transducer	2	Adjustable cam—exploded view	8
Pitot-static capsule unit—exploded view	3	Cam unit CU8—exploded view	9
Transistor and magnetic amplifiers and component panel	4	Mounting tray, Type B	10
Underside of motor plate	5	Servo amplifier—circuit and block diagrams	11
Left-hand view of transducer	6	Pitot-static transducer, Type B—circuit and schematic diagrams	12

LIST OF APPENDICES

	App.		App.
Standard serviceability test	1	Tests and adjustments	3
◀ Fault diagnosis	2	Removal and replacement of components	4 ▶

General description

1. Pitot-static transducer, Type B (fig. 1) forms part of air data system, Mk. 1B, and is housed in transducer mounting tray, Type B (para. 53), into which it is guided by means of locating dowels fitted to the rear of the chassis, and to which it is secured by the captive screw mounted on the front of the chassis. The unit measures approximately 7 by 5 by 7 inches and weighs approximately 5½ lb.

2. A 25-way socket, PT1, and a 12-way plug PT2, are mounted on the front panel. Orifices are provided for the two adapters labelled PITOT and STATIC which connect the unit to the appropriate line from the aircraft's pressure head. The static pressure adapter is of $\frac{3}{8}$ in. and the pitot pressure adapter $\frac{1}{8}$ in. outside diameter. The transducer is protected by a cover which may be removed after unscrewing two screws at the rear of the unit. No external controls are provided.

RESTRICTED

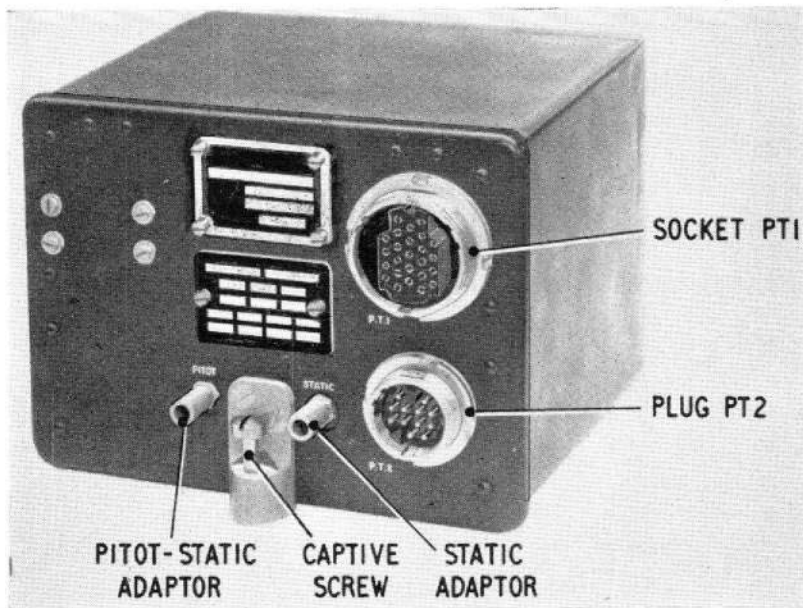

Fig. 1. Pitot-static transducer, Type B

3. All power supplies are derived from the power supply unit, and these supplies are listed, together with their application within the unit, in Table 1. The unit requires a warm-up period of three minutes prior to operational use.

4. The pitot-static transducer is a servomechanism designed to fulfil a requirement for the accurate measurement of Indicated Air Speed (I.A.S.) between 100 and 750 knots within the temperature range -20 degrees C to $+50$ degrees C. The unit provides a follow-up servo system delivering a synchro output corresponding to I.A.S. for transmission to the appropriate display unit, together with a potentiometer output for use as a primary signal associated with the air data computer. The output signals are listed in Table 2.

5. The transducer consists of a front panel, pillar and side bracket assembly supporting a gear plate (fig. 2) and motor plate (fig. 5). The gear plate and motor plate are suitably drilled to house or support the various components, bearings and drive spindles associated with the gear train. The unit may be considered to consist of a pitot-static capsule unit (para. 13) and a servo system, the servo system incorporating the following:—

- (1) servo amplifier comprising:—
 - (a) transistor amplifier
 - (b) demodulator
 - (c) magnetic amplifier.

Note . . .

Although referred to as sub-assemblies, both the transistor amplifier TAI (3C5161) and the magnetic amplifier MA1 (3C635) are separate and replaceable units.

(2) gear train incorporating:—

- (a) adjustable cam
- (b) motor-tachogenerator
- (c) transmitter synchro CX1
- (d) cam unit CU8 (controlling synchro CX1, I.A.S. output)
- (e) precision helical potentiometer RV3 (log (P-S) output)
- (f) microswitch MSW1

6. Four trimmer potentiometers are provided for calibration purposes as follows:—

- (1) RV1, for setting-up the velocity feedback signal from the tachogenerator.
- (2) RV2 and RV4. These form the potentiometer network associated with RV3 and are adjusted during setting-up to provide the correct log P-S output voltage from the 20V (X) input to RV2 (para. 39).
- (3) RV5, for setting-up the correct level of error voltage from the pick-off coils.

7. A component panel (fig. 4) supports the following:—

- (1) Demodulator circuit MR1, MR2, R14.
- (2) R8, in parallel with RV2 (20V (X) supply).
- (3) R9, R10, pick-off bridge resistors associated with RV5.
- (4) Servo amplifier input resistors, R5, R6.
- (5) Overall feedback resistors, R11, R12, R13.

8. Connections are also made to the base of the capsule unit (fig. 5) and the transistor and magnetic amplifier tag strips (fig. 4). Pre-set potentiometers RV1, RV2, RV4 and RV5 are mounted on the upper side of the gear plate (fig. 2), capacitor C1 on the underside of the

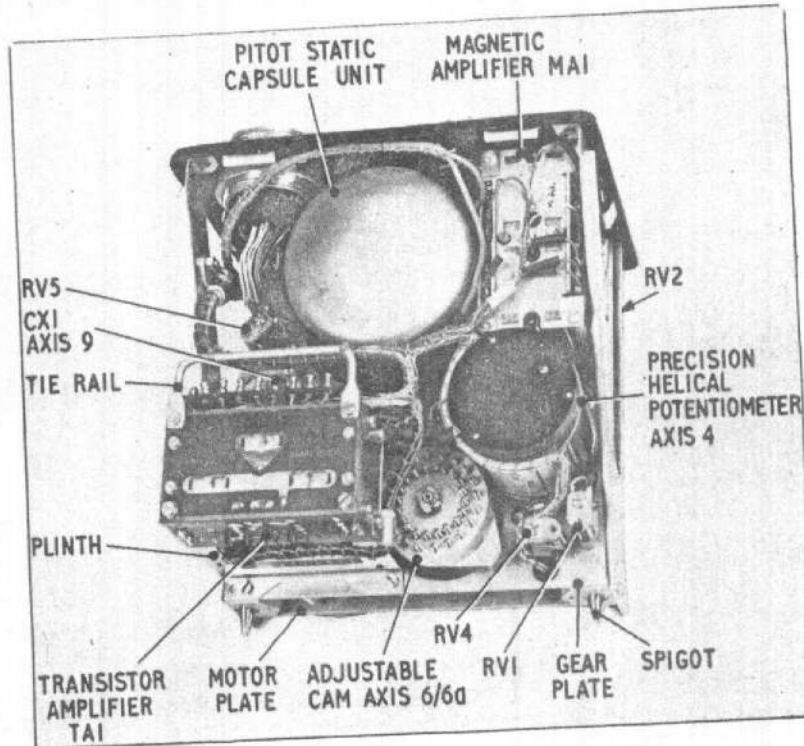

Fig. 2. Interior of transducer

motor plate (fig. 5) and C2 on the upper side of the motor plate. Power supplies, input and output signals, etc., are distributed directly to and from the two plugs PT1 and PT2, these are listed in Table 3.

9. The function of the pitot-static transducer unit is summarised in paragraphs 10 to 12, and a detailed description is given in subsequent paragraphs.

Summary of operation

10. The I.A.S. information is derived from a sensitive differential air pressure gauge consisting of a capsule contained in a sealed chamber, the inside of the capsule being connected to the static line and the sealed chamber being connected to the pitot line from the aircraft's pressure head. In flight, the pitot or dynamic pressure is greater than the static pressure by an amount depending upon the square of the airspeed, and this causes the capsule to contract with increasing air-speed, the deflection of the capsule being proportional to the log of pitot minus static pressure (log P-S). The capsule is connected by a linkage to the moving-iron armature of a variable-reluctance pick-off. The output from the pick-off coil is the error signal, this signal is amplified in the servo amplifier and used to drive the motor-tacho-generator. A suitable gear-train causes the coil of the pick-off to rotate and follow the moving-iron armature until a zero error signal or null position is found. The servo-loop action thereupon ceases.

11. Because the deflection/pressure law of individual capsules may vary about the optimum,

an adjustable cam—effectively a variable gear—is incorporated in the gear-train between the motor and the pick-off coils. This cam is calibrated to a high order of accuracy in order to compensate for any capsule non-linearity (para. 47), and its effect is such that approximate measurements of (P-S) pressure from the pick-off coils are converted into measurements of correct (P-S) pressure throughout the gear train.

12. The angular rotation of a power-driven spindle is thus a measure of the deflection of the capsule, the tacho-generator stabilizing the servo-loop by providing an angular-velocity feed-back signal, the servo amplifier system being further stabilized by overall feed-back. The servo mechanism drives the transmitter synchro CX1 and the precision potentiometer RV3. The output of synchro CX1 is made proportional to I.A.S. by the suitable coupling of a fixed cam in the gear train, and this output is applied to the display unit. A voltage output proportional to log (P-S) is provided by RV3 for use in the air data computer. Microswitch MSW1 has its contacts set so that at speeds below 50 to 55 knots this switch effectively reverses the motor and the servo thus runs on and off the gear stop (para. 45) position.

PITOT-STATIC CAPSULE UNIT

Description

General

13. The pitot-static capsule unit is illustrated in fig. 3. This unit consists of a chamber fitted with two adaptors, one of which is the inlet for static pressure (45) and the other (45a) the inlet for pitot pressure. Sealed outlets are provided in the base, (49) for terminals (47) through which

RESTRICTED

RESTRICTED

- 1 COVER
- 2 BI-METAL SWITCH
- 3 STATIC CAPSULE (25)
- 4 HEATER ELEMENT
- 5 INSULATED BLOCK (35)
- 6 BRACKET AND PLATE
- 7 BRIDGE (19, 40)
- 8 COVER 'O' RING
- 9 CAPSULE BALANCE WEIGHT
- 10 SPRING
- 11 SPRING ANCHOR
- 12 SPRING TAG
- 13 SCREW AND LOCKNUT
- 14 JEWEL MOUNTING
- 15 LINKAGE ASSEMBLY
- 16 VANE PIVOT ARM
- 17 VANE ARM BALANCE WEIGHT
- 18 LEAF SPRING ASSEMBLY (38)
- 19 BRIDGE (7, 40)
- 20 ADJUSTMENT SCREW
- 21 PIVOT JEWEL MOUNTING
- 22 SPACER (39)
- 23 CAPSULE BRACKET
- 24 CAPSULE ADAPTER
- 25 STATIC CAPSULE (3)
- 26 CAPSULE SUPPORT
- 27 CAPSULE PIPING
- 28 CAPSULE BRACKET
- 29 JEWEL MOUNTING ASSEMBLY (including bi-metal strip)
- 30 DIAPHRAGM HOUSING
- 31 SPRING CONTACT
- 32 BLOCK
- 33 BI-METAL CONTACT
- 34 SWITCH BI-METAL
- 35 INSULATED BLOCK (5)
- 36 PACKER
- 37 SOLDER TAG
- 38 LEAF SPRING (18)
- 39 SPACER (22)
- 40 PICK-OFF BRIDGE (7, 19)
- 41 E COILS
- 42 LAMINATIONS
- 43 BOLT, VANE ARM ADJUSTING
- 44 VANE
- 45 ADAPTOR, STATIC PRESSURE
- 45a ADAPTOR, PITOT-STATIC PRESSURE
- 46 BEARING PAD
- 47 SEALED TERMINAL
- 48 SPINDLE
- 49 BASE ASSEMBLY
- 50 SPINDLE 'O' RING
- 51 BEARING HOUSING

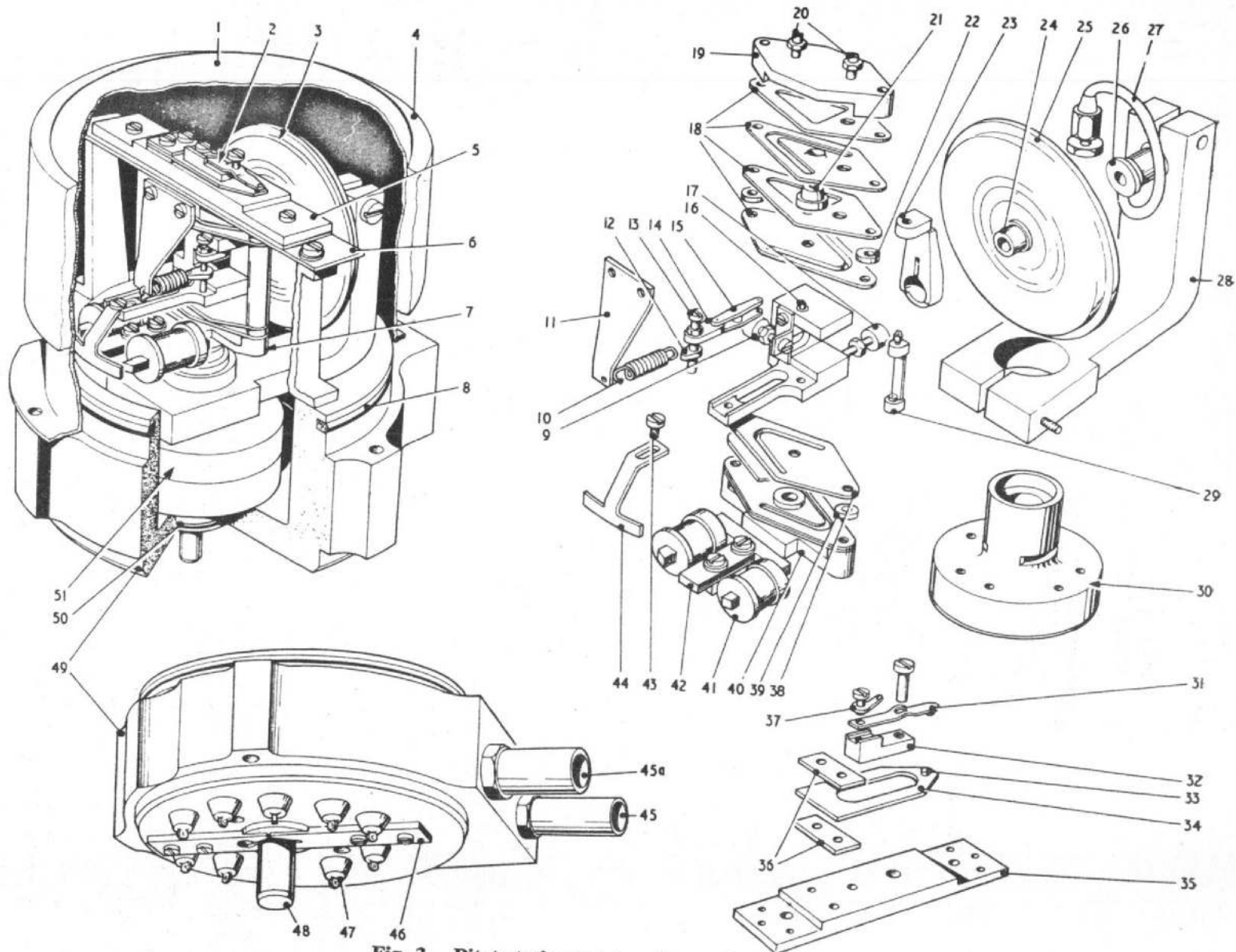

Fig. 3. Pitot-static capsule unit—exploded view

are routed the electrical connections for the thermostat switch and pick-off coils. A further outlet in the base, sealed by a synthetic rubber 'O' ring (50), is provided for the spindle (48). A detachable cover (1), also sealed by an 'O' ring (8), fits over the collar of the base-plate and a 40-watt heater element (4) surrounds the cover. The heater is controlled by the internal bi-metal switch (2), and this circuit is described in para. 16.

14. The design of the capsule unit provides for the following:—

(1) The rigid support of the capsule (25) by means of the capsule bracket (28) and capsule support (26).

(2) Conversion of the capsule movement into an angular movement of the vane (44). The vane is attached to the vane arm (16) which is pivoted in jewel mountings supported by a bridge (7), the vane being biased against backlash by means of an anchored spring (10, 11, 12) and adjusted by means of the bolt (43). Angular movement between vane and capsule is transmitted by means of the capsule bracket (23) attached to the capsule adaptor (24). The bracket supports a jewel mounting assembly (29) incorporating an adjustable bi-metal strip. One end of a linkage assembly (15) is supported in the jewel mountings and the other in a second jewel mounting (14) which is part of the bridge assembly. The angular movement between vane and linkage is adjustable (13) by pivoting this jewel mounting.

(3) Conversion of the movement of the vane into an error signal by means of the variable-reluctance pick-off. The E coils (41) on their laminations (42) are attached to the spindle (48) by means of a pick-off bridge (40). The spindle and E coils are free to rotate over a limited arc, and are supported by two sets of bearings, the lower bearing being contained in a bearing housing (51). Superimposed on the bearing housing is a diaphragm housing containing a corrugated beryllium-copper diaphragm which acts as an expansion joint. The spindle axis is further stabilized by means of vee-blocks and a bearing pad (46), and the spindle extrudes through the base assembly (49) via the synthetic-rubber 'O' ring seal. The lower end of the spindle is clamped to the 72 degree sector (*fig. 5*) which meshes with gear 76T on axis 6A (*para. 42*).

(4) Correction of errors arising from varying temperature co-efficients, and compensation of errors arising from 'g' forces.

(a) Temperature error correction. The bi-metal strip in the jewel mounting assembly (29) is adjusted during the calibration of the capsule unit to compensate for errors in the capsule and the supporting mechanism, and the corrugated diaphragm in the diaphragm housing (51) compensates for errors in the spindle supporting mechanism. The heater (4) prevents the transducer icing up at very low ambient temperatures. The heater is controlled by the bi-metal switch (2) which

consists of an insulated block (35) on which is mounted the switch bi-metal (34) contact (33) and the spring contact (31, 32). The bi-metal switch switches on the heater at a nominal ambient temperature of 5 deg. C (*para. 19*).

(b) Errors arising from 'g' forces are counter-balanced by the capsule balance weight (9), the vane arm balance weight (17) and the leaf spring assembly (18) supporting the jewel mountings in which pivots the vane arm.

(5) Electrical interconnections by means of the internal cable forms. External connections are made by means of the sealed terminals (47).

Capsule

15. The pitot-static capsule (25) is constructed of corrugated beryllium-copper cheeks joined with non-corrosive solder, and fitted with the support (26) and the adaptor (24). A spiral of copper tubing (27) connects the inside of the capsule to the pitot adaptor (45a). The (P-S) pressure varies between 16.33 mbs at an I.A.S. of 100 knots and 1240.23 mbs at 750 knots.

Heater circuit

16. The sealed volume of the capsule unit is temperature controlled by means of the bi-metal thermostat switch contained in the unit, and the associated heater element surrounding the removable cover. The heater element consists of a non-inductive winding positioned in its insulated covering so as to place the element in close proximity to the cover and thus provide maximum heat transference to the capsule unit, and minimum heat dissipation in other directions. The heater is connected to the 115V, 400 c/s phase A and B supply, which is made or broken via contacts RLB/1 of the high-speed relay RLB, located in the computer. The solenoid of RLB is operated by the -30V supply via two switches in series, the bi-metal switch located in the static capsule unit and a height switch located in the height gearbox of the computer unit. The height switch closes at and above an altitude of 10 500 ft, the bi-metal switch being ineffective and the heater remaining disconnected below this altitude.

17. The bi-metal switch is adjusted during calibration to close at a temperature of 5 degrees C ± 2 degrees C, and to open within 2 degrees of the temperature at which it closed.

Principle of operation

18. The inside of the capsule is subjected to the pressure of still air while the dynamic or Pitot pressure is applied to the sealed chamber containing the capsule, the pressure differential causing the capsule to contract with increasing air speed. This movement is magnified in the linkage system and transmitted to the rotating arm to which the moving-iron armature (vane) of the variable-reluctance pick-off is attached.

19. The variable-reluctance pick-off uses magnetic coupling in order to measure the difference

between the position of the vane (source of motion) and the spindle (source of error signal) and this forms the error detector of the transducer servo mechanism. It consists essentially of the two magnetic structures, one in the shape of an E (pick-off coil) and the other in the shape of an I (vane). In the absence of pressure change, no movement will be imparted by the capsule, the vane (assuming the servo follow-up action is complete) will be symmetrically positioned in regard to the pick-off coil and the output from the pick-off will be a minimum signal or null. A change of pressure will result in the movement of the vane away from the null position, and a consequent output signal from the pick-off coils. This output is amplified and used to drive the motor-tachogenerator in a null-seeking direction.

20. The circuit of the variable-reluctance pick-off is given in fig. 12B, from which it can be seen that an alternating voltage is applied to the primary, which is wound co-axially with the secondary on the outer limbs of the E core. If the vane is in its centre position, equal voltages are induced in the series-aiding secondary coils, the bridge network is therefore balanced (RV5 being adjusted to this condition) and no output is produced across the load resistor R5. When the vane is moved the air gaps between the E and I cores will no longer be equal, increased flux will be carried in the limb having reduced reluctance and decreased flux will be carried in the limb having increased reluctance. In this manner the voltage induced in one coil increases while that induced in the other decreases. The bridge is no longer balanced and an output voltage of a certain magnitude and phase appears across the load resistor R5. This error signal is power-amplified in the servo amplifier in order to provide the necessary torque and fed to the control winding of the motor, the reference winding of which is maintained at a constant voltage. The phase of the pick-off voltage is also related to this reference, so that the direction of rotation of the motor is such as to cause the servo loop to seek the pick-off null.

SERVO SYSTEM

Servo amplifier (fig. 11)

21. The purpose of the servo amplifier is to provide a suitable a.c. power output which is related in amplitude and phase to the error signals from the capsule unit, the output from the servo amplifier being the command signal driving the motor-tachogenerator and associated gear train. The servo amplifier consists of a transistor amplifier, a phase-sensitive demodulator, and a magnetic amplifier, the overall gain being in the region of 130000. It should be noted that identical transistor amplifiers and magnetic amplifiers are used throughout the air data system. Inputs to the servo amplifier are discussed in para. 31.

Transistor amplifier, 3C5161

22. The transistor amplifier (fig. 4) is a printed-circuit sub-assembly secured by four screws to a plinth which raises it above the synchro mounting

plate, the main component panel also being secured on small brackets held by the two front securing bolts. The amplifier tag strip (labelled at the base of the plinth) is accessible at the lower rear, and a tie rail is provided for the associated cable form.

23. The circuit (fig. 11A) consists of an input stage, resistance-capacity coupled to a driver stage, coupled by a phase-splitter transformer to a Class B push-pull output stage. Germanium PNP junction transistors are used throughout. The input impedance is 800 ohms, and the input signal is fed to the base of VT1 (OC73), which has +9V applied to the emitter and -6V (A) to the collector. VT1 is resistance-capacity coupled via C3 and R6 to VT2 (OC73), which operates with the same emitter and collector voltages and is biased by R7, decoupled by C5. The phase-splitter transformer TR1 couples VT2 to the output stage, the primary being tuned by C4 and C6 to give maximum gain at 400 c/s. A germanium junction diode, MR1, provides temperature compensation for the bias voltage of the output stage, VT3 and VT4 (OC72's). The emitter bias supply is -6V (A) fed via R10 and R11 respectively. The collectors are fed with -6V (B) via the centre tap of the primary of TR2, which is tuned by C7 for maximum gain at 400 c/s. TR2 matches VT3 and VT4 into the output load.

Demodulator (fig. 11A)

24. The demodulator circuit consists of the silicon diode rectifiers MR1 and MR2 and the 2.2K resistor R14, all of which are mounted on the main component panel (fig. 4).

25. The demodulator is a phase-sensitive device which operates from a 400 c/s signal and a 400 c/s reference phase. It will respond to signals which are either in phase with, or in anti-phase to, the reference signal, but will not respond to any quadrature voltages which may be present.

26. The demodulator converts the a.c. output from the transistor amplifier into a unidirectional signal for application to the magnetic amplifier. The polarity of this d.c. level depends upon the phase of the a.c. input to the demodulator, the amplitude of the d.c. output being proportional to the amplitude of the a.c. input from the transistor amplifier.

Magnetic amplifier, 3C635

27. The magnetic amplifier (fig. 4) is a sub-assembly of conventional design which delivers 5 watts a.c. power to the control-phase winding of the motor-tachogenerator. The input resistance is 74 ohms, the current gain at 4mA d.c. input is 20, and an output of 120mA r.m.s. is available as a command signal to the motor-tachogenerator, which is tuned to 400 c/s by capacitor C1 in parallel with the control winding.

28. The circuit (fig. 11A) of the magnetic amplifier consists of two matched transducers each with two silicon diode rectifiers, (MR1-MR4), with R1 and two pre-set resistors, RV1 and RV2,

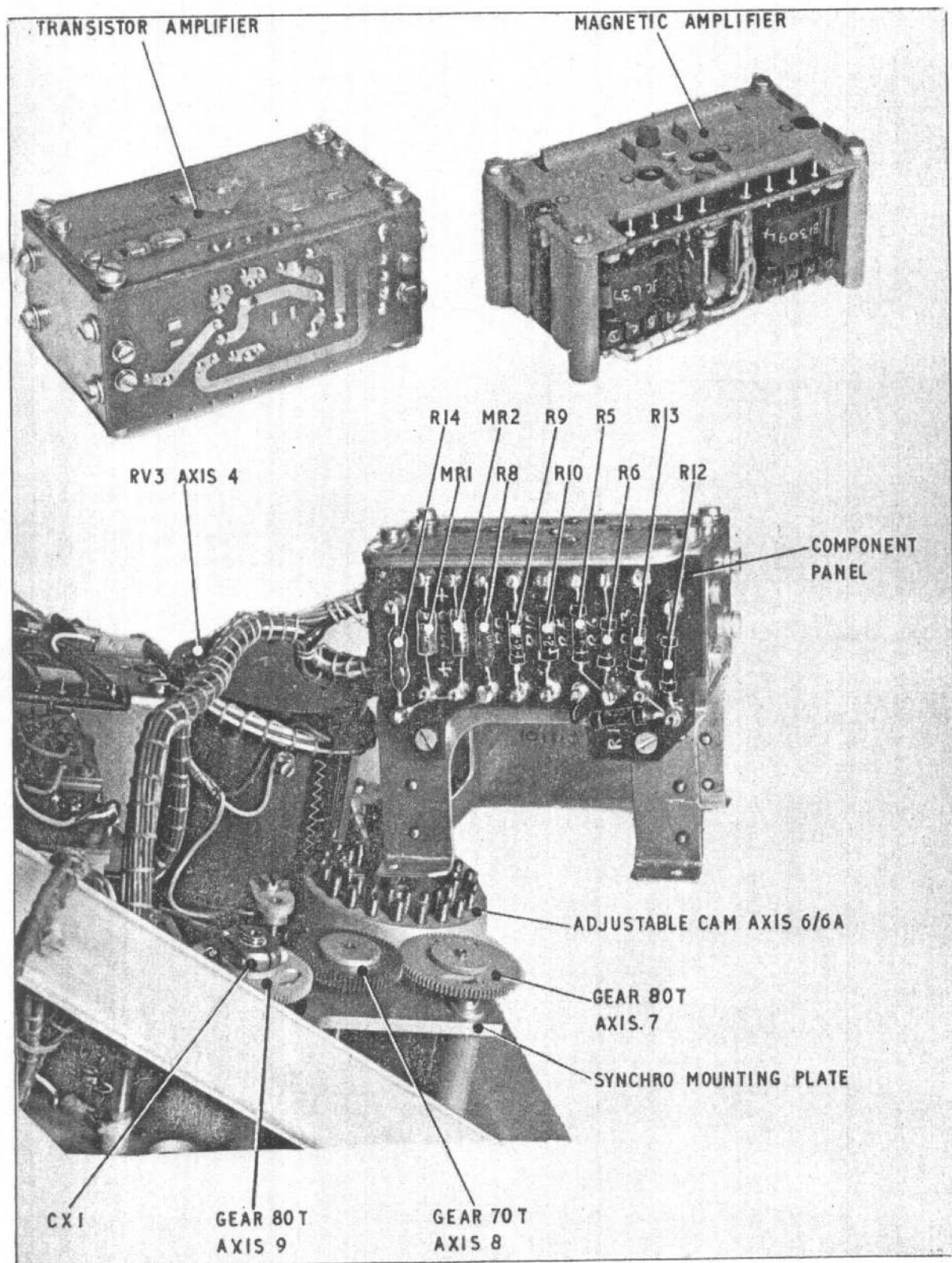

Fig. 4. Transistor and magnetic amplifiers and component panel

RESTRICTED

controlling the bias circuit. All components are suitably mounted on a metal chassis. Internal connections are made via tagboards located at each side of the chassis and these are labelled on the chassis. The sub-assembly is provided with a flux shield protecting the capsule unit.

29. The sub-assembly functions as a Class B magnetic amplifier connected in such a manner as to provide a load current which is the difference between the a.c. currents flowing in the transducers. The transducers are fed from the opposite ends of a centre-tapped 170V, 400 c/s supply, and the phase of the load current is therefore reversed when the direction of the d.c. control current reverses.

30. The transducer operating points are set independently by means of the internal pre-set resistors, RV1 and RV2, the bias current being derived from the -30V d.c. supply. These bias control potentiometers are adjustable through two access holes in the chassis.

Inputs to servo amplifier

31. The inputs to the servo amplifier are summed at tag 'a' on the transistor amplifier and consist of error, damping, and overall feed-back signals as follows:—

(1) The error signal derived from the pick-off coils of the capsule unit is fed to the amplifier via the load resistor R5.

(2) An angular-velocity feed-back signal (damping signal) is derived from RV1, which is in parallel with the output winding of the tachogenerator. This signal is fed via the load resistor R6, and has a range of 0 to 2.75V r.m.s.

(3) An overall feed-back signal is developed from the servo amplifier output via the T network comprising R11, R12 and R13. This signal stabilizes the gain of the servo amplifier, improves the low frequency response, and removes unwanted time lags from the servo loop.

Motor-tachogenerator

32. The motor-tachogenerator consists of a 2-phase, 2-pole squirrel cage motor with a 4-pole induction tachogenerator mounted on the same shaft, the motor being designed for 400 c/s operation. The reference phase of the motor section is energized by the 50V reference supply, and the control winding is fed with the power-amplified command signal from the output of the magnetic amplifier, this voltage being in time phase quadrature with the reference voltage. The resultant rotating field causes the motor to rotate at a speed proportional to the amplitude of the command signal, the direction of rotation being determined by the phase of the command signal voltage, which may either lead or lag the reference voltage by 90 degrees. The motor spindle is connected by a pinion to the gear train.

33. The tachogenerator provides a sinusoidal voltage of constant frequency, but with an amplitude proportional to the angular velocity of the shaft. The generator has two stator windings—excitation and output—the excitation winding being fed with 8V a.c.

34. The output from the generator is known as velocity feed-back and is fed to the input of the servo amplifier via the load resistor R6. A pre-set potentiometer RV1 is connected across the

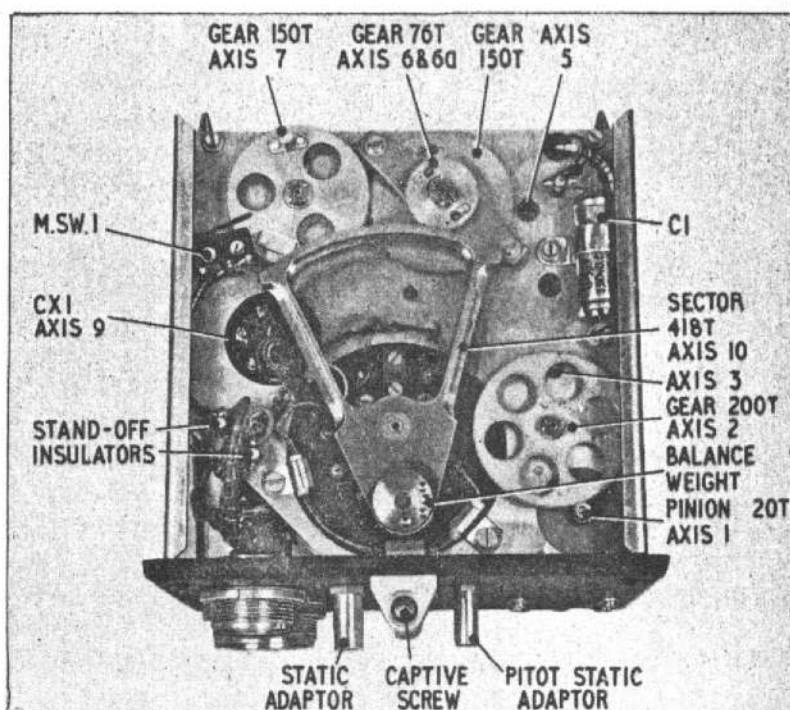

Fig. 5. Underside of motor plate

RESTRICTED

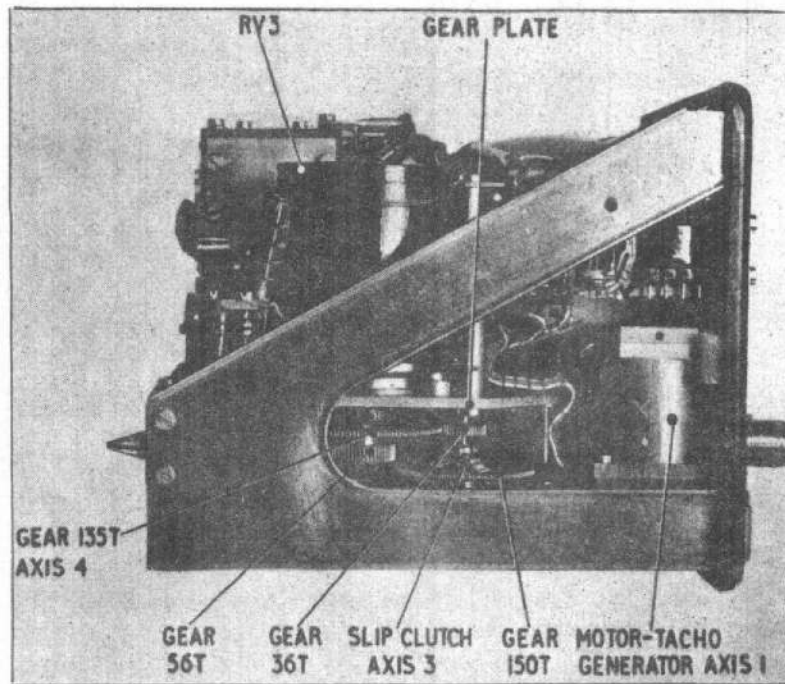

Fig. 6. Left-hand view of transducer

generator output winding to enable the maximum velocity feed-back signal to be varied between zero and 2.75V r.m.s. Should the signal be inadequate, any disturbance will cause the servo to oscillate or hunt, whereas if the signal is too large, the servo will be over-damped and sluggish. RV1 is adjusted during setting-up to provide a satisfactory measure of velocity feed-back.

Outputs from servo system (Table 2)

35. The motor-tachogenerator drives a gear-train from which are derived the outputs from (a) transmitter synchro CX1, and (b) potentiometer RV3.

Transmitter synchro

36. Control transmitter synchro CX1 feeds I.A.S. signals via the computer to the appropriate display unit. This synchro rotates through approximately 295 degrees over the range 100 to 750 knots, and the spindle of CX1 is controlled by cam unit CU8 to provide an output proportional to I.A.S.

37. The transmitter synchro has a single-phase rotor which is energised by the 115V phase A and B supply, applied by means of suitably-mounted slip-rings and brushes. When the two input leads, R1 and R2, are thus excited by a.c., voltages are induced in the stators by transformer action. The stator windings are spaced 120 degrees apart, and the rotor flux links each stator coil according to the position of the rotor. The three line voltages S1, S2 and S3 thus have a magnitude and phase which defines the position of the shaft with respect to the stator. These voltages are applied to a transformer synchro at the appropriate destination.

38. The function of a transformer synchro is to convert the three output voltages from the transmitter synchro into a single voltage that is proportional to the angular difference of the transmitter and transformer synchro shafts, the voltages applied to S1, S2 and S3 of the transformer synchro producing a flux distribution identical with that of the transmitter synchro.

Potentiometer RV3, log P-S voltage

39. The output of potentiometer RV3 is known as log (P-S) and forms one of the primary variables fed to the air data computer. The log (P-S) voltage is derived from the 20V (X) supply and is developed across the potentiometer chain RV2—R8/RV3/RV4. RV3 is a ten-turn helical potentiometer which has a nominal value of 1K. During calibration, RV4 is pre-set to compensate for any discrepancy in the nominal value of RV3, and RV2 is pre-set to bring the voltage at the junction of RV3/RV4 to a specified value so that the log (P-S) voltage from RV3 wiper ranges between approximately 6V at 100 knots and 15V at 750 knots ((P-S) pressure 16.33 and 1240.23 mbs respectively). This voltage is applied to the servo amplifier of the log mach number servo gear-box in the air data computer.

Gear train

General

40. The gear train (fig. 12A) is accommodated between a gear plate (upper) (fig. 2) a synchro mounting plate (fig. 4) and a motor plate (lower) (fig. 5), certain parts of the gear train extruding above the gear plate or beneath the motor plate. The gear and motor plates are drilled to house the capsule unit base, which is bolted between the

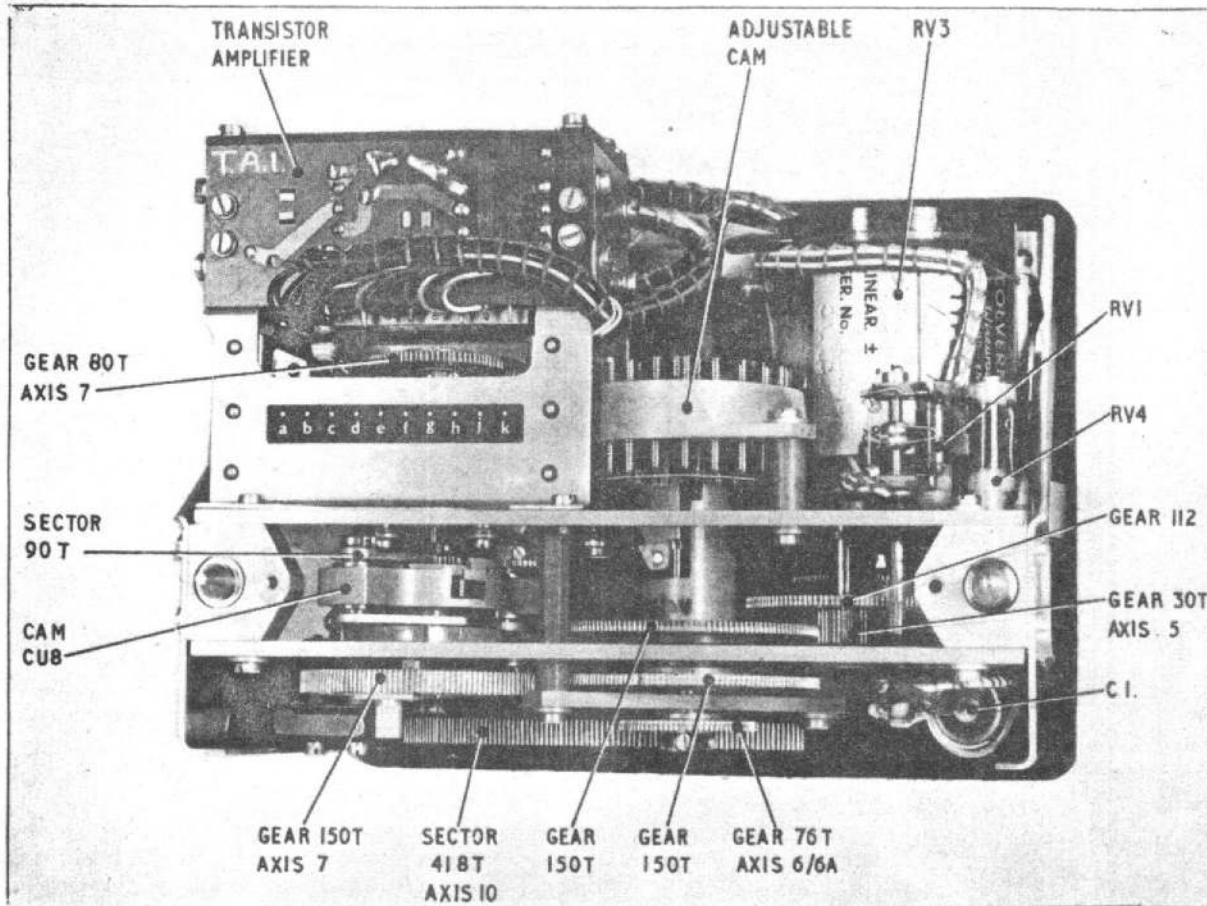

Fig. 7. Rear view of transducer

two plates, also the synchro CX1, potentiometer RV3, the motor-tachogenerator, and the associated gear system, suitable bearings being provided for the various gear spindles. Split clamps facilitate the removal of gears or components, and clamps provided on the gear plate for RV3, and on the synchro mounting plate for CX1, enable these components to be adjusted during setting-up.

41. The gear train consists of ten axes, axis 1 being the drive from the motor-tachogenerator. Unless otherwise specified, aluminium alloy is the material used for the gears and stainless steel for pinions and spindles. All bearings are flanged ball bearings and are a light push fit in their housings and on their spindles. Split gears are introduced on axes 5 and 6 to counteract backlash (*para.* 43). To protect the gear train, a slip clutch (*para.* 44) is provided at axis 3, and a gear stop (*para.* 45) at axis 7.

42. For the purpose of description, pinion 20T, gear 200T, etc., is used to signify a pinion with 20 teeth, gear with 200 teeth, etc. The action of the gear train is as follows (*fig.* 12A):—

- (1) Axis 1. The command signal from the output of the servo amplifier is fed to the motor, the spindle of which carries a pinion 20T. This pinion is below the motor plate.
- (2) Axis 2. The pinion 20T meshes with the intermediate gear 200T which also extrudes beneath the motor plate, the spindle of axis 2 carrying a pinion 20T.

- (3) Axis 3. The pinion 20T meshes with gear 150T, controlled by the slip clutch, the spindle of axis 3 carrying pinion 36T.
- (4) Axis 4. The pinion 36T meshes with gear 135T. This gear drives the helical potentiometer RV3, the output of which is a voltage proportional to log (P-S). The spindle of RV3 also carries a boss and pinion 56T.
- (5) Axis 5. The pinion 56T meshes with the intermediate gear 112T, the spindle of axis 5 carrying pinion 30T.
- (6) Axis 6. The pinion 30T meshes with gear 150T on axis 6, the lower bearing of which is fitted in a bearing support beneath the motor plate. The gear 150T above the motor plate drives the adjustable cam (*para.* 47) which controls the spindle on the concentric axis 6A, this spindle carrying the gear 76T which meshes with the sector 418T. Integral with the gear 150T above the motor plate is a second gear 150T below the motor plate.
- (7) Axis 6A. The gear 76T on axis 6A meshes with the sector 418T.
- (8) Axis 7. The gear 150T meshes with a further gear 150T which incorporates cam unit CU8, and this gear is fitted with a gear stop. CU8 converts the logarithmic function of axis 7 into I.A.S. at Axis 7A, axis 7A carries the boss and gear 80T, which extrudes above the synchro mounting plate.

(9) Axis 8. The gear 80T meshes with gear 70T above the synchro mounting plate.

(10) Axis 9. The gear 70T meshes with gear 80T which drives the spindle of synchro CX1. CX1 rotates through 295 degrees in a counter-clockwise direction for increasing I.A.S., over the range 100 to 750 knots.

(11) Axis 10. The spindle of axis 10 (which carries the pick-off bridge within the capsule unit) extrudes beneath the motor plate and is driven by the sector 418T. The sector is fitted with balance weights and spans an arc of 72 degrees between the centre line of the spindle and the end teeth.

Split gears

43. A split gear (16, fig. 8) is a combination of

two gears with adjacent faces, one being staked to the boss and the other being free to rotate. The relative position of the gear faces is controlled by two coiled springs, inset in slots on opposite sides of each gear face. One end of each spring is anchored to the fixed gear and the other to the free gear. When meshed with the mating gear, the two portions of the gear rotate against the action of the springs, which tends to spread the two sections apart, thus varying the gear tooth width and reducing back-lash.

Slip clutch (overload clutch)

44. The slip clutch (fig. 6) protects the gear train in the event of overload. It consists of a dished spring fitted on the intermediate gear spindle at axis 3, the gear (150 teeth) being freely

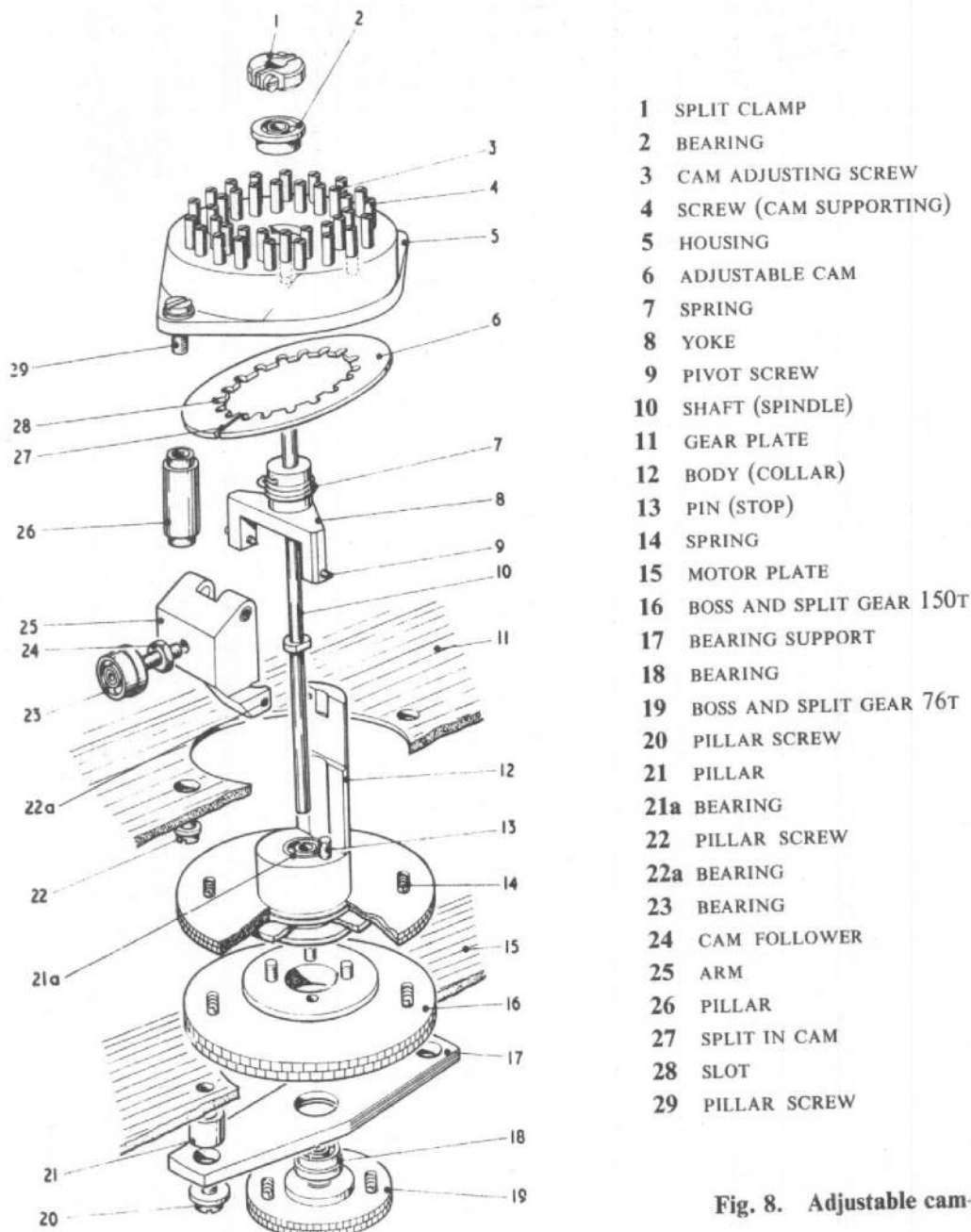

- 1 SPLIT CLAMP
- 2 BEARING
- 3 CAM ADJUSTING SCREW
- 4 SCREW (CAM SUPPORTING)
- 5 HOUSING
- 6 ADJUSTABLE CAM
- 7 SPRING
- 8 YOKE
- 9 PIVOT SCREW
- 10 SHAFT (SPINDLE)
- 11 GEAR PLATE
- 12 BODY (COLLAR)
- 13 PIN (STOP)
- 14 SPRING
- 15 MOTOR PLATE
- 16 BOSS AND SPLIT GEAR 150T
- 17 BEARING SUPPORT
- 18 BEARING
- 19 BOSS AND SPLIT GEAR 76T
- 20 PILLAR SCREW
- 21 PILLAR
- 21a BEARING
- 22 PILLAR SCREW
- 22a BEARING
- 23 BEARING
- 24 CAM FOLLOWER
- 25 ARM
- 26 PILLAR
- 27 SPLIT IN CAM
- 28 SLOT
- 29 PILLAR SCREW

Fig. 8. Adjustable cam—exploded view

RESTRICTED

mounted on the slip clutch boss and clamped against the spring by a split clamp. The split clamp is adjusted so that the rotation of the spindle is transmitted to the gear on normal loads, but slips when the load is slightly below the overload rating for the motor.

Gear stop

45. A gear stop is provided on the gear 150T located under the motor plate at axis 7. The gear stop engages with a motor plate stop at the extreme limits of the gear train travel. These extreme limits are well beyond the normal operating limits of the gear train.

46. The gear ratios are detailed in fig. 12A.

Adjustable cam (fig. 7 and 8)

47. As stated in para. 11, because the deflection/pressure law of the capsule may vary about the optimum, it is necessary to introduce a variable gear to compensate for this error. An adjustable cam is therefore introduced at axis 6, the action of the cam being transmitted to axis 6A which carries the gear 76T meshing with the sector. The adjustable cam is driven by the gear 150T

located above the motor plate, which meshes with pinion 30T at axis 5.

48. Integral with the gear 150T referred to above, is a collar (12) fitted with a stop (13). The base of the collar supports a spindle (10) (axis 6A) in a bearing (21a). This spindle extrudes beneath the motor plate and carries a boss and gear 76T (19) which meshes with the sector 418T driving the spindle (axis 10) to which is attached the pick-off bridge and E coils. Integral with spindle 6A is a spring-loaded yoke (7, 8) mounted in which, and hinged in the vertical plane, is an arm (25) bearing (22a), and cam-follower (24). The cam-follower traverses the under side of the cam (6) which is a drilled disc of nickel-plated beryllium copper forming a circular tract, approximately $\frac{1}{4}$ in. wide, for the cam-follower. The cam is split (27) to allow for adjustment in the vertical plane, and slots (28) cut in the inner periphery of the cam engage with the waist of the cam adjusting screws (3) of which there are 20, the waist of each adjusting screw being inset in the slots and thus retaining the cam in position. A further 20 supporting screws (4) bear on the outer peri-

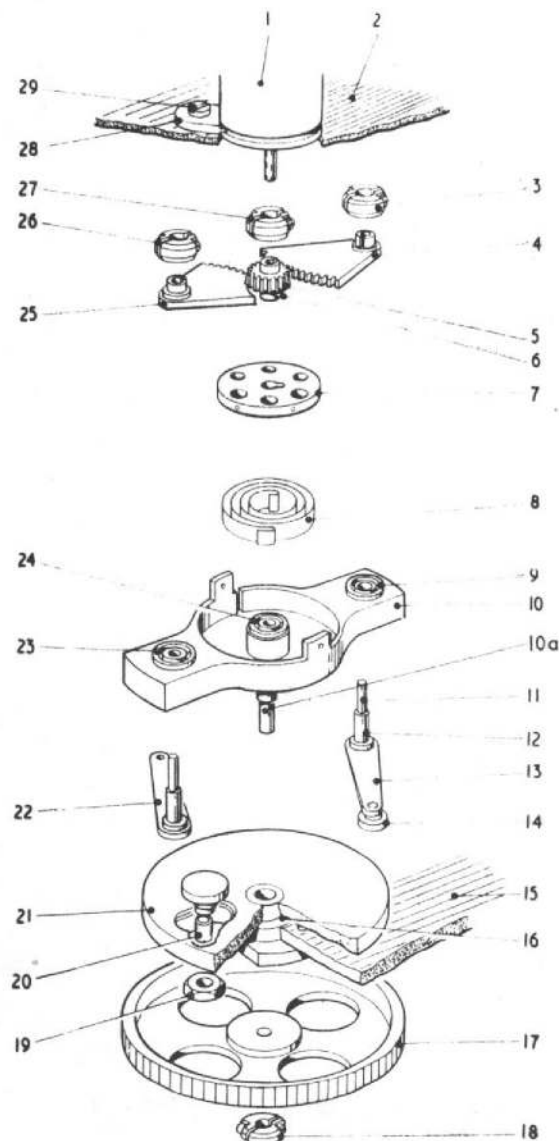

- 1 POTENTIOMETER RV3
- 2 GEAR PLATE
- 3 SPLIT CLAMP
- 4 GEAR SEGMENT (25)
- 5 GEAR (30T) AND PIN
- 6 KEY (5)
- 7 INNER SPRING HOUSING
- 8 SPRING
- 9 BEARING
- 10 SPINDLE AND SPRING HOUSING
- 10a SPINDLE
- 11 ROLLER ARM SPINDLE (12)
- 12 ROLLER ARM SPINDLE (11) (LOWER SECTION)
- 13 ROLLER ARM
- 14 BEARING SPINDLE AND BEARING
- 15 MOTOR PLATE
- 16 BEARING HOUSING
- 17 GEAR 150T AND BOSS
- 18 SPLIT CLAMP
- 19 NUT 4BA
- 20 ADJUSTER
- 21 CAM CU1A
- 22 ROLLER ARM AND SPINDLE
- 23 BEARING
- 24 BEARING
- 25 GEAR SEGMENT (4)
- 26 SPLIT CLAMP
- 27 SPLIT CLAMP
- 28 POTENTIOMETER CLAMP
- 29 CLAMP SCREW

Fig. 9. Cam unit CU8—exploded view

RESTRICTED

phery of the cam and are adjusted to maintain the plane of the cam at right angles to the perpendicular. The supporting screws and cam adjusting screws are threaded through a housing (5) spaced above the gear plate by two pillars (26). The cam adjusting screws are locked in the housing by means of a nylon lock washer inset in the base.

49. The action of the adjustable cam is such that if all cam adjusting screws and supporting screws are wound so that the cam presents a horizontal surface to the cam-follower, then a 1 : 1 gear ratio will exist between axis 6 and axis 6A. Calibration of the pitot-static transducer over the I.A.S. range of 100 to 750 knots is obtained by the adjustment of the screws, and this causes the cam to become distorted spirally. The cam-follower wheel, in following the spiral, advances or retards the arm (25) and bearing (22a) and consequently axis 6A, by the amount pre-set during calibration. The yoke stop (13) drives against the bearing (22a) thus transferring the advance/retard action to axis 6A and the subsequent gear train, and thereby introducing a variable gear ratio which compensates the servo loop for any non-linear characteristics of the capsule and linkage.

Cam unit CU8 (fig. 9)

50. The cam unit mechanism consists of a drive spindle (axis 7) and a fixed cam, the follower of which is cranked to drive a sector/pinion system, the pinion driving the spindle (axis 7A) carrying the gear 80T meshing with the intermediate gear 70T (axis 8) which drives the gear 80T and spindle of CX1 on axis 9.

51. The spindle (10a) and spring housing (10) are driven by boss and gear 150T (17) (axis 7) which meshes with gear 150T (axis 6). The cam (21) is fitted with an adjuster (20) consisting of a washer rotatable in an eccentric slot, which is available for setting-up purposes. The cam follower action is obtained by the roller (14) traversing the cam face. The roller arm (13) is cranked to a shouldered spindle, the lower section (12) of which is supported in a bearing (9) in the housing (10). A similar bearing arm (22) acts as an idling counter-balance. A sector 90T is attached to the upper section of each spindle (11), both sectors meshing with the pinion 30T (5), which is keyed (6) to the inner spring housing (7) and supported by the bearing (24), the spindle being stabilized by action of the spring (8). The pinion 30T is mounted on the spindle (axis 7A) which also carries gear 80T, meshing with intermediate gear 70T (axis 8). This, in turn, drives gear 80T, the boss of which supports the spindle of CX1 (axis 9).

SERVICING

52. Full instructions in regard to the setting-up of the pitot-static transducer will be issued later. The following is a summary of the basic setting-up requirements:—

- (1) Capsule unit,
 - (a) bearing assembly—fitting of assemblies and bearings, greasing, etc., checking of intermediate and total permissible torque,
 - (b) bi-metal linkage—correct adjustment to compensate for errors due to temperature changes. Adjustment of linkage ratio to give required deflection,
 - (c) heater circuit—correct setting-up of bi-metal switch to prescribed temperature limits,
 - (d) error signal output—physical symmetry of vane and E coils. Adjustment of RV5 to produce optimum null signal.
- (2) Servo response—checking of servo stability and adjustment of velocity feed-back
- (3) Adjustable cam—calibration of cam over specified I.A.S. range,
- (4) I.A.S. synchro output—calibration check of the rotation of CX1 over the specified I.A.S. range,
- (5) Log (P-S) voltage output—setting-up of RV2/RV3/RV4 network, adjustment of CU8 and calibration of potentiometer RV3 over specified I.A.S. range.

MOUNTING TRAY, TYPE B

Ref. No. 6A/5937

53. The mounting tray (fig. 10) is a pressed aluminium frame which houses the transducer. The vertical bracket at the rear of the tray supports two bushes which locate the dowels on the rear of the transducer. A mounting bush is provided at the centre front of the tray to accept the captive mounting screw of the pitot-static transducer.

54. The mounting tray is attached to the aircraft by four spring anti-vibration mountings, two bolted to the under side of the front cross-member, and two bolted to the vertical rear cross-member. The anti-vibration mountings have a rating of 4 lb. An earthing braid is provided for bonding purposes.

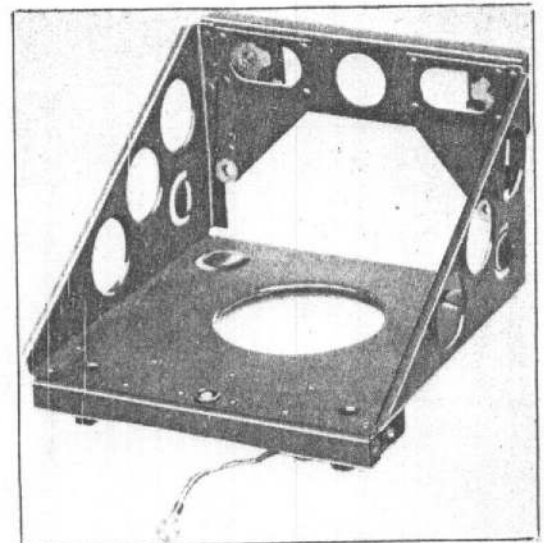

Fig. 10. Mounting tray, Type B

RESTRICTED

Table 1
Power supplies

PT1	PT2		
H	K	Motor-tachogenerator	
J	M	50V	Motor reference phase
		8V	Tachogenerator excitation phase
O		Transistor Amplifier	
P		+9B	Emitter bias
S		-6V(A)	Collector voltage, VT1 and VT2
		-6V(B)	Collector voltage, VT3 and VT4
	J	Demodulator	
		Ref. 1	
G	F	Magnetic Amplifier	
D	D	-30V	Transductor bias windings
E	E	AC1	} Transductor load windings
		AC2	
C	A	Capsule Unit	
B	C	3V(X)	} Pick-off coil, primary excitation
G	F	3V(Y)	
Q		-30V	Operation of heater circuit, (RLB, Computer) via bi-metal switch
Q		115V(A)	Heater element
Q		Transmitter Synchro CX1	
W		115V(A) R2	} CX1 rotor
		115V(B) R1	
	L	Potentiometer RV3	
		20V(X)	Log (P-S) voltage

Table 2
Outputs

PT1			
L			Potentiometer RV3, log (P-S) (to computer)
X	S1	} CX1, I.A.S. Synchro (to display via computer)	
Y	S2		
Z	S3		

Table 3
Connections to socket PT1 and-plug PT2

PT1		PT2	
A	(P-S) heater	A	3V(X)
B	3V(Y)	B	Sig. Earth
C	3V(X)	C	3V(Y)
D	AC1	D	AC1
E	AC2	E	AC2
F	Bias Earth	F	-30V
G	-30V	G	Bias Earth
H	50V	H	20V(Y)
J	8V	J	Ref. 1
K	(P-S) Bi-metal	K	50V
L	Log (P-S)	L	20V(X)
M		M	8V
N	20V(Y)		
O	+9V		
P	-6V(A)		
Q	115V(A)		
R	Sig. Earth		
S	-6V(B)		
T			
U			
V			
W	115V(B)		
X	S1		
Y	S2		
Z	S3		

} I.A.S. Synchro

Table 4
Component values

Resistor	Value	Watts	Tolerance %	
Resistors, fixed carbon				5905-99-021
R5	5.6K	$\frac{1}{4}$	5	5331
R6	150K	$\frac{1}{4}$	5	6135
R7				
R9	2.2K	$\frac{1}{4}$	1	5715
R10	2.2K	$\frac{1}{4}$	1	5715
R11	82K	$\frac{1}{4}$	5	6111
R12	1M	$\frac{1}{4}$	5	6965
R13	470	$\frac{1}{4}$	5	5201
Resistors, fixed, wire-wound				5905-99-011
R8	680	$1\frac{1}{2}$	5	3251
R14	2.2K	$1\frac{1}{2}$	5	3263
Resistors, variable, wire-wound				
RV1	2.5K	1	10	3AQC 6/8
RV2	1K	1	10	3AQC 6/8
RV3 (linearity $\pm 0.1\%$)	1K	$\frac{1}{2}$	0.5	3AQC 40/2
RV4	500	1	10	3AQC 6/8
RV5	250	1	10	3AQC 6/8
Capacitors, fixed, metal/paper				5910-99-011
C1 0.5 microfarad $\pm 25\%$	150V working			5566
Capacitors, Tantalum pellet				
C2 1.25 microfarad $\pm 20\%$	25V working			3AQC 144/8
Rectifiers, silicon diode MR1, MR2				3AQC 95/3
Socket PT1 (Position 0) 25-way				5935 99-056-0380
Plug PT2 (Position 0) 12-way				5935-99-056-0150

RESTRICTED



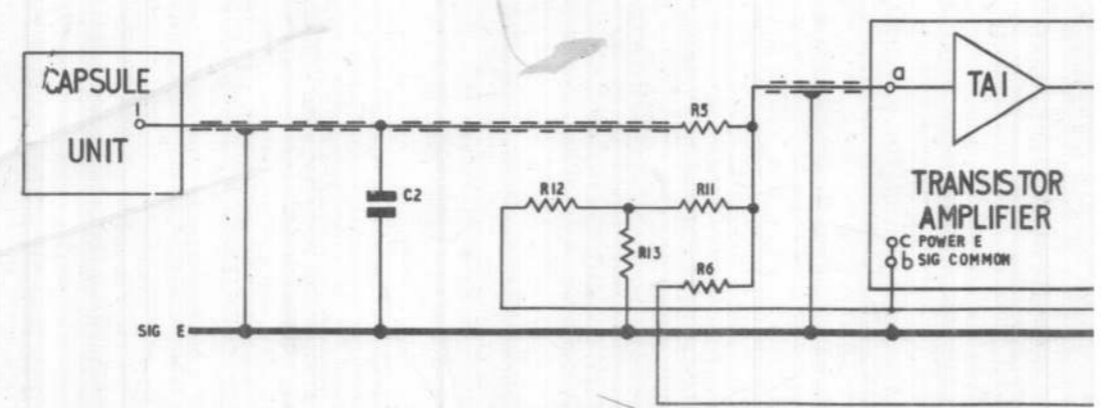
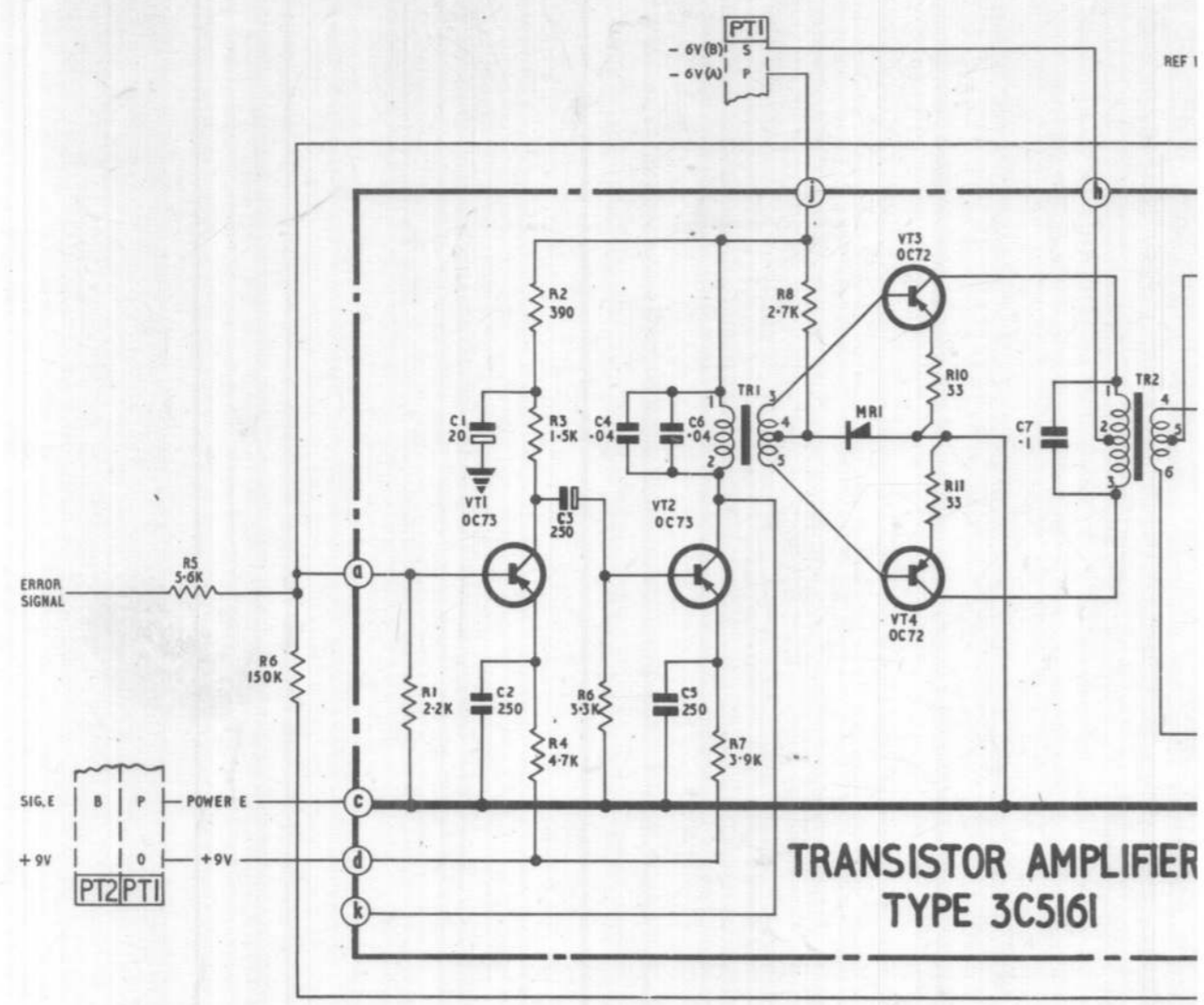

A.D.S. Mk.I.B SERVO AMPLIFIER

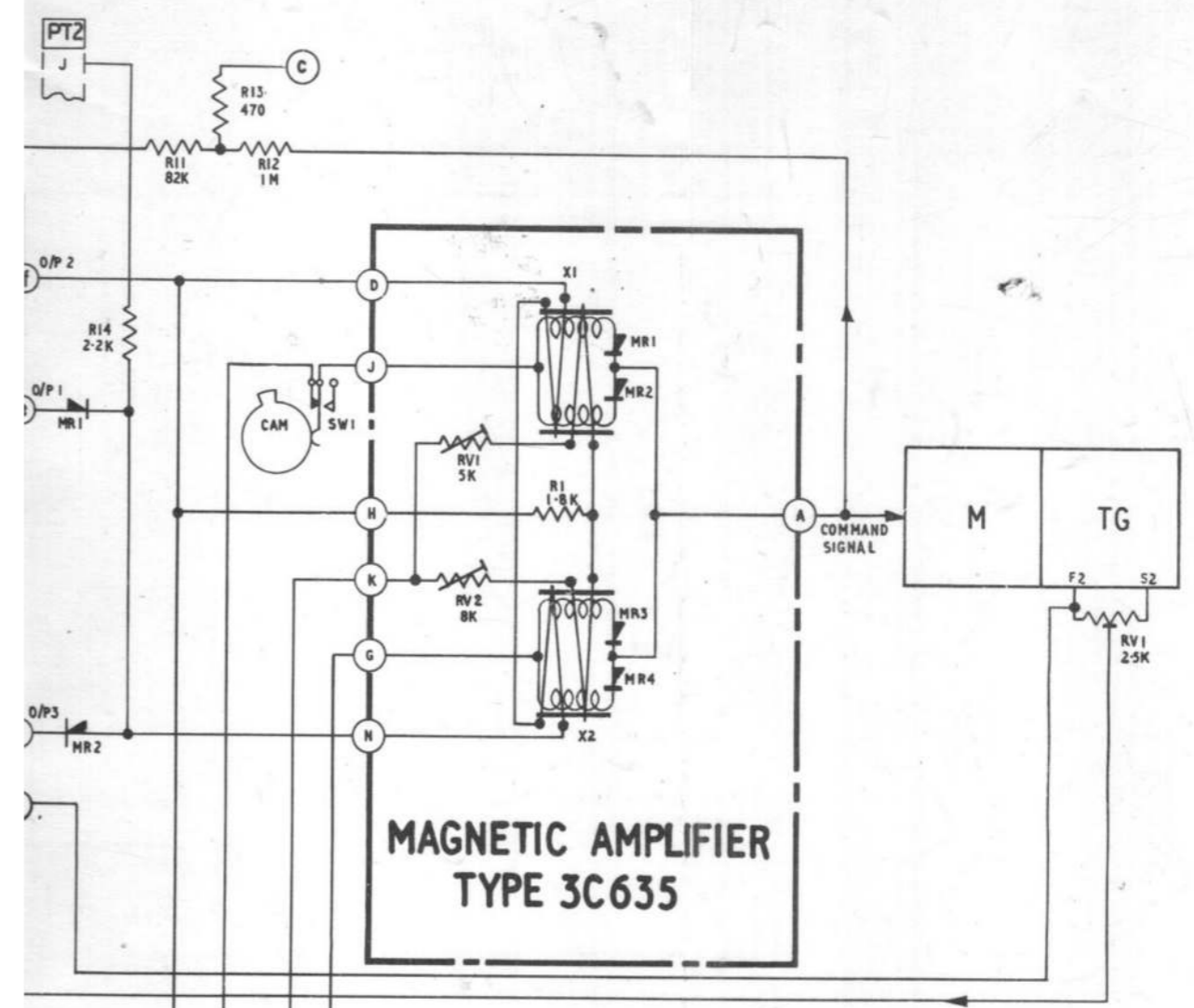

CIRCUIT DIAGRAM FIG. II A

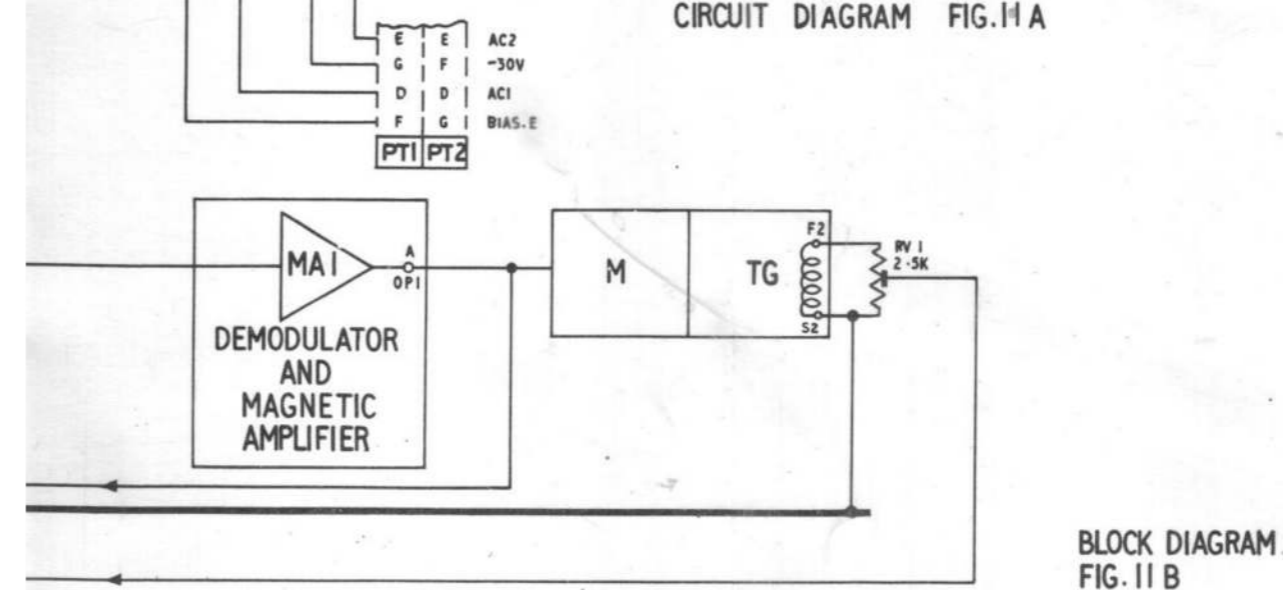

**BLOCK DIAGRAM
FIG. II B**

**PITOT-STATIC TRANSDUCER)
RESTRICTED**

FIG. II

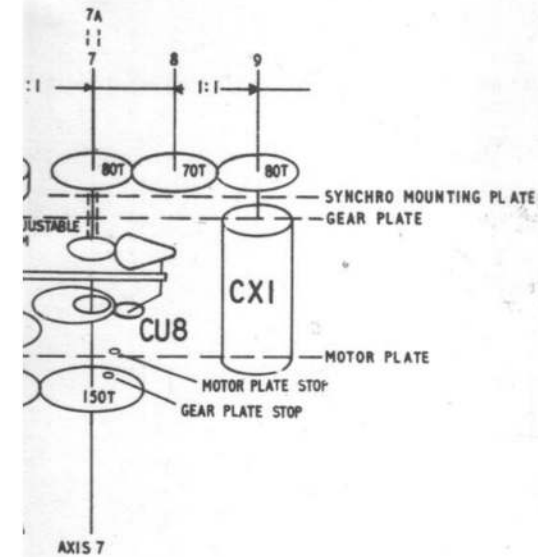
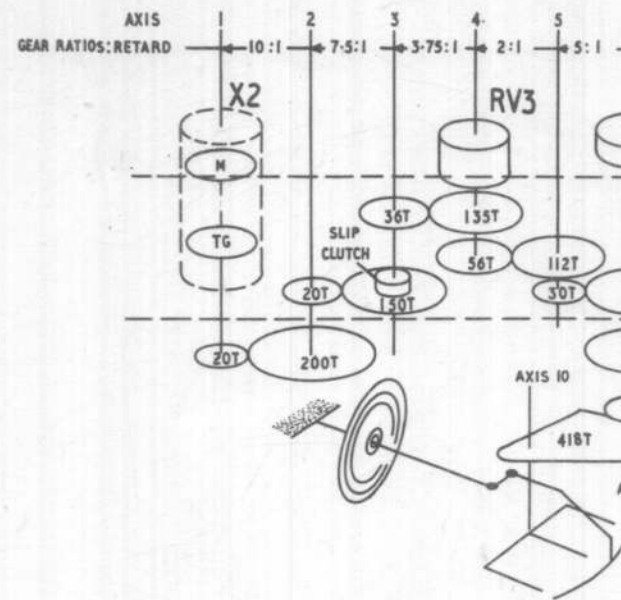

SCHEMATIC FIG.12 A

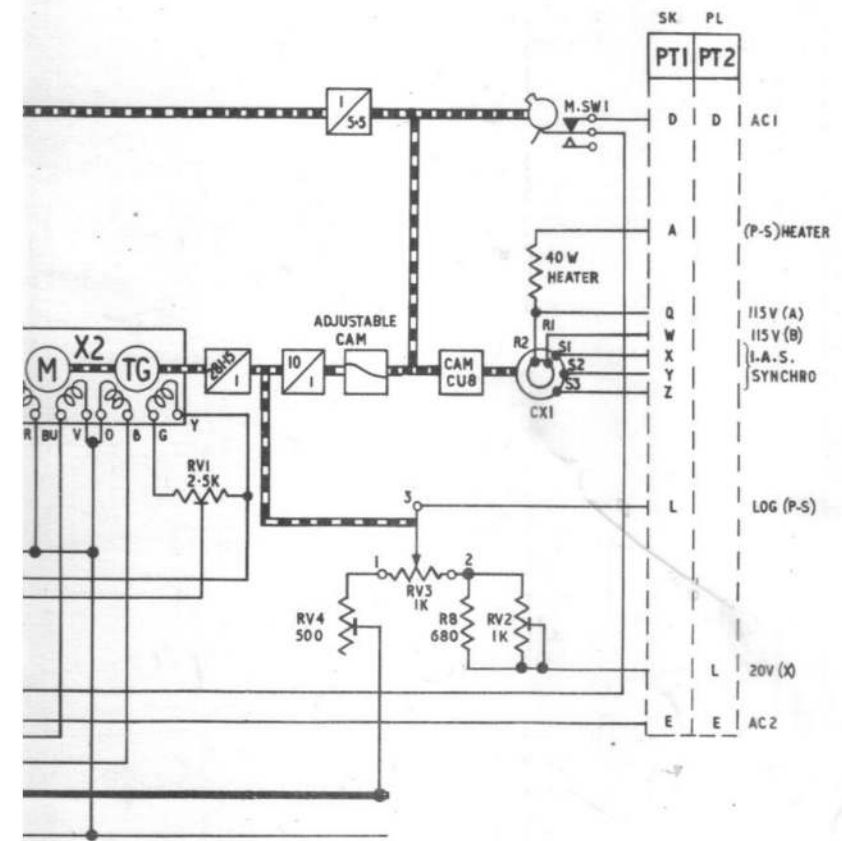
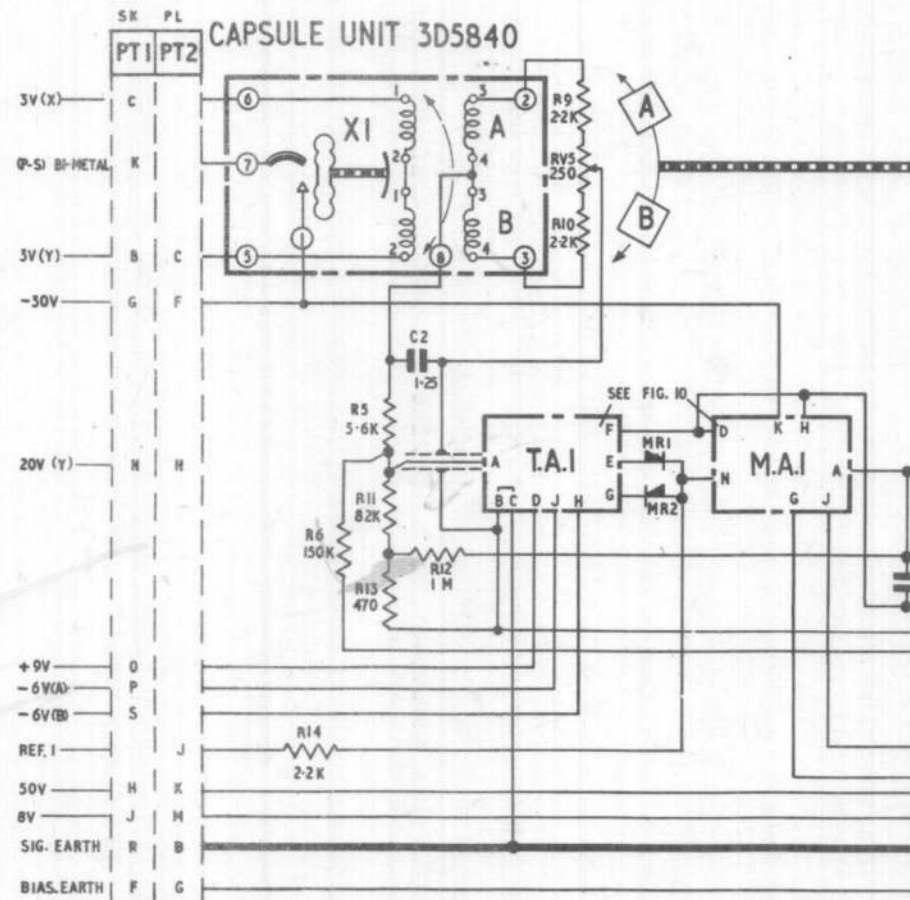

FIG.12 B

A.D.S. MK.I.B PITOT-STATIC TRANSDUCER TYPE B REF. 6A/6435 CIRCUIT DIAGRAM

FIG.12

AIR DIAGRAM
6320 AF/MIN
ISSUE 1
ISSUED BY MINISTRY OF AVIATION
FOR PROMULGATION BY
AIR MINISTRY ADMIRALTY

This file was downloaded from the RTFM Library.

Link: www.scottbouch.com/rtfm

Please see site for usage terms, and more aircraft documents.



Instrument panel from a MiG-21 (XP558)