

Appendix 3
POWER SUPPLY UNIT, TYPE B, Ref. No. 6A/6822
and TYPE C, Ref. No. 6A/8548

SERVICING
FAULT DIAGNOSIS

LIST OF CONTENTS

	<i>Para.</i>		<i>Para.</i>
<i>General</i>	1	<i>Zero readings on test set meters</i>	10
<i>Fault symptoms</i>	3	<i>Faulty components</i>	
<i>Fault clearance</i>	5	<i>Torque switch (S1) and power failure relay (S2)</i>	11
<i>Wiring faults</i>	8	<i>Transformers T2, T1, T3</i>	13
<i>Power supplies</i>	9	<i>Summary</i>	16

LIST OF TABLES

		<i>Table</i>
<i>Test sequence 1</i>	1	
<i>Test sequence 2</i>	2	
<i>Fault summary</i>	3	

LIST OF ILLUSTRATIONS

		<i>Fig.</i>
<i>115V routing and input to transformers</i>	1	
<i>Relay S2 and component board</i>	2	

General

1. The majority of faults on equipment will occur in service and some of them may have more than one cause: some reported faults may not be obvious when the equipment is subjected to test. As a first step to fault diagnosis the standard serviceability test (SST) should be carried out.

2. The power supply unit (PSU) can be divided into two main channels, input and output, each with its own sub-divisions:—

- (1) Input to:—
- (a) Torque switch S1.
 - (b) Power failure relay S2.
 - (c) Transformer T1.
 - (d) Transformer T2.
 - (e) Transformer T3.

(2) Output from:—

- (a) Power failure relay S2.
- (b) Transformer T1.
- (c) Transformer T2.
- (d) Transformer T3.

A schematic diagram showing the 115V routing and the inputs to all components of sub-para. (1) is given in fig. 1. Fig. 2 shows the component board and relay base wiring of S2.

Fault symptoms

3. From the results of the SST one or more of the following symptoms may be apparent:—

- (1) No outputs at all (para. 10).
- (2) All outputs faulty (an unlikely fault, but see Table 3, Item 8).
- (3) Some outputs faulty (Table 3).

RESTRICTED

RESTRICTED

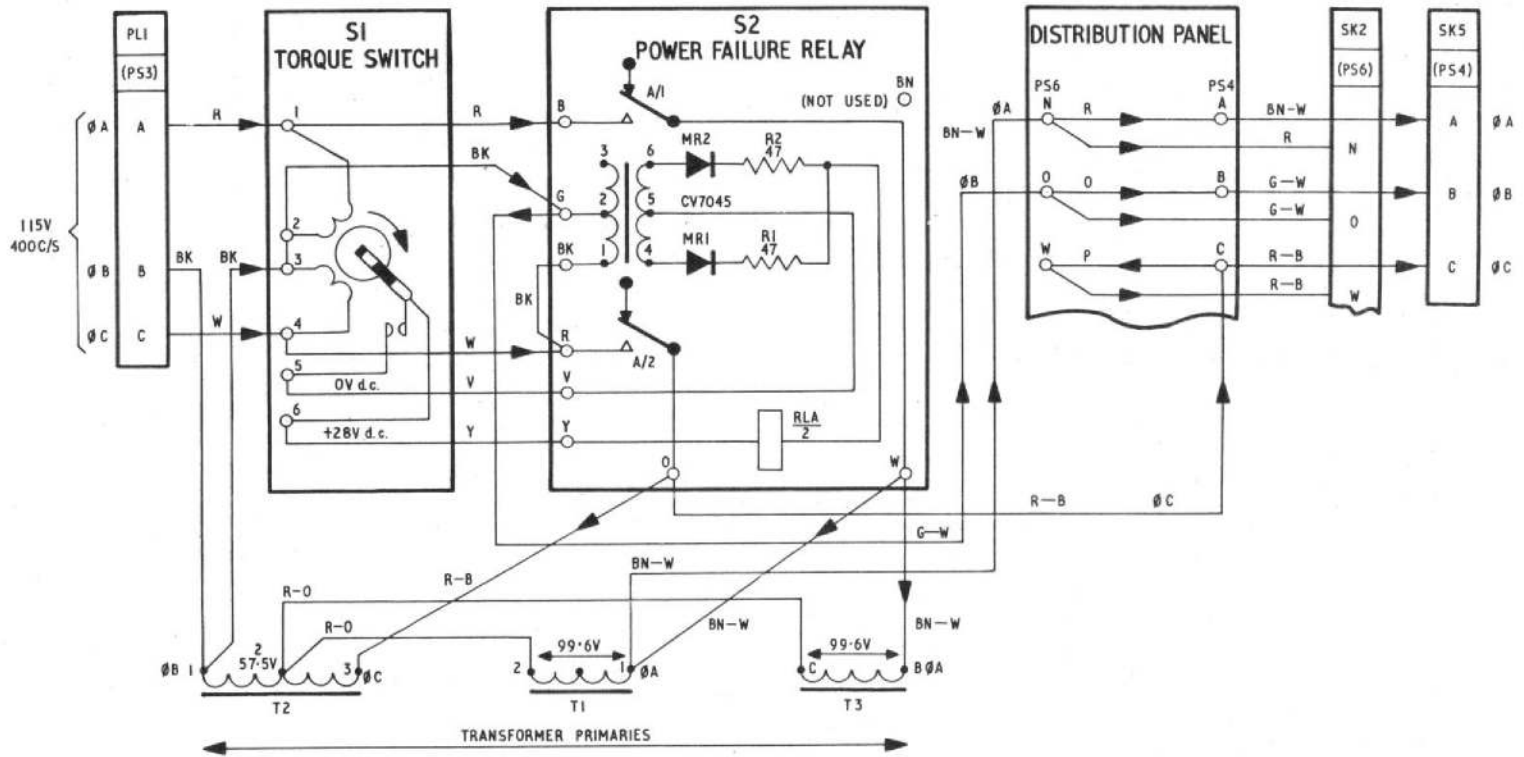

Fig. 1. 115V routing and input to transformers

4. It should be noted that any input fault will automatically give rise to errors in some or all outputs.

Fault clearance

5. Faults are cleared either by the adjustment or replacement of the sub-unit or component concerned. A fault due to a component not held in the second line range of spares will result in the PSU being declared unserviceable.

6. When a suspect sub-unit or component is changed the SST will be carried out to ensure that only the sub-unit or component is at fault. If the fault persists after an item has been changed then the original item should be replaced and the next step in the sequence investigated.

7. Fault diagnosis should continue until either the PSU is repaired or a point is reached beyond which the level of servicing authorized permits no further investigation; at this stage the PSU will be declared unserviceable.

Wiring faults

8. A check on the wiring of the PSU is included in App. 4 although it is considered that a fault therein is unlikely. However, should a continuity check prove advisable it must be borne in mind that not all outputs are fed directly from source to the sockets on the front panel: for example, the 115V, 20V, transducer 3V(X) and 3V(Y) and -6V(B) supplies are routed via the distribution panel. If a particular output produces no reading at the test set meter, it should be remembered that a voltage check with a multimeter at relevant pins of the distribution panel of the PSU (App. 5, Table 3), will give an indication as to whether or not the output socket under test is at fault.

Power supplies

9. It is assumed that the power at PL1 (PS3) is correct as this is supplied by the test set, but should a sub-unit or component be suspect then the voltage supplies from the test set should be checked before proceeding further.

Zero readings on test set meters

10. Zero readings on all test set meters at all test switch positions can be caused by one, or more, of several factors:—

- (1) Failure of S1.
- (2) Failure of S2.
- (3) Failure of transformer T2.
- (4) Wiring fault.

Faulty components

Torque switch (S1) and power failure relay (S2)

11. A faulty S1 will produce no voltage outputs from the PSU. In order to confirm this fault carry out the sequence of Table 1.

12. A faulty S2 will produce either:—

- (1) No voltage outputs from the PSU.
- (2) Outputs from T2 but not from T1 or T3.

In the event of the fault being as per sub-para. (1) carry out the sequence of Table 1. If the fault is of the nature of sub-para. (2) a check of the voltage between S2-O and S2-W will show if S2 is the cause.

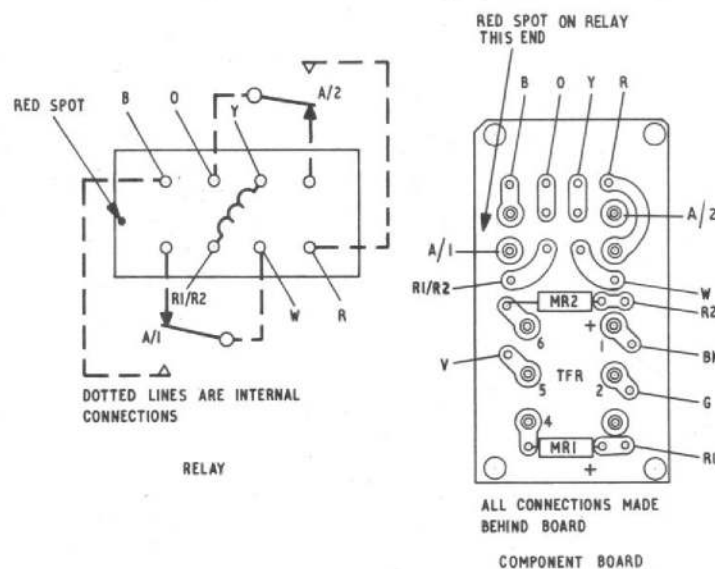

Fig. 2. Relay S2 and component board

RESTRICTED

Transformers T2, T1, T3

13. Transformer T2. A faulty primary winding on T2 will result in no voltage outputs from the PSU. Carry out the sequence of Table 1 to ensure that the fault lies with T2. If the outputs from T1 and T3 are correct but all T2 outputs are incorrect, it can be assumed that T2 is faulty; change the transformer and carry out the SST. If the 50V output is correct but all or some of the d.c. outputs are incorrect, then the relevant output components should be tested as detailed in App. 4 before changing the transformer.

14. Transformer T1. If outputs from T2 and T3 are correct, change T1 and carry out the SST.

15. Transformer T3. If outputs from T2 and T1 are correct, carry out the 20V and/or 10V balance procedure of App. 4. If outputs are still out of tolerance, change T3 and carry out the SST.

Note . . .

If T2 outputs are correct but there are no outputs from T1 and T3, carry out the sequence of Table 2.

Summary

16. Table 3 lists the symptoms which may appear after the standard serviceability test has been carried out (col. (b)), the component(s) most probably at fault (col. (c)) and a suggested course of action (col. (d)).

TABLE 1
Test sequence 1

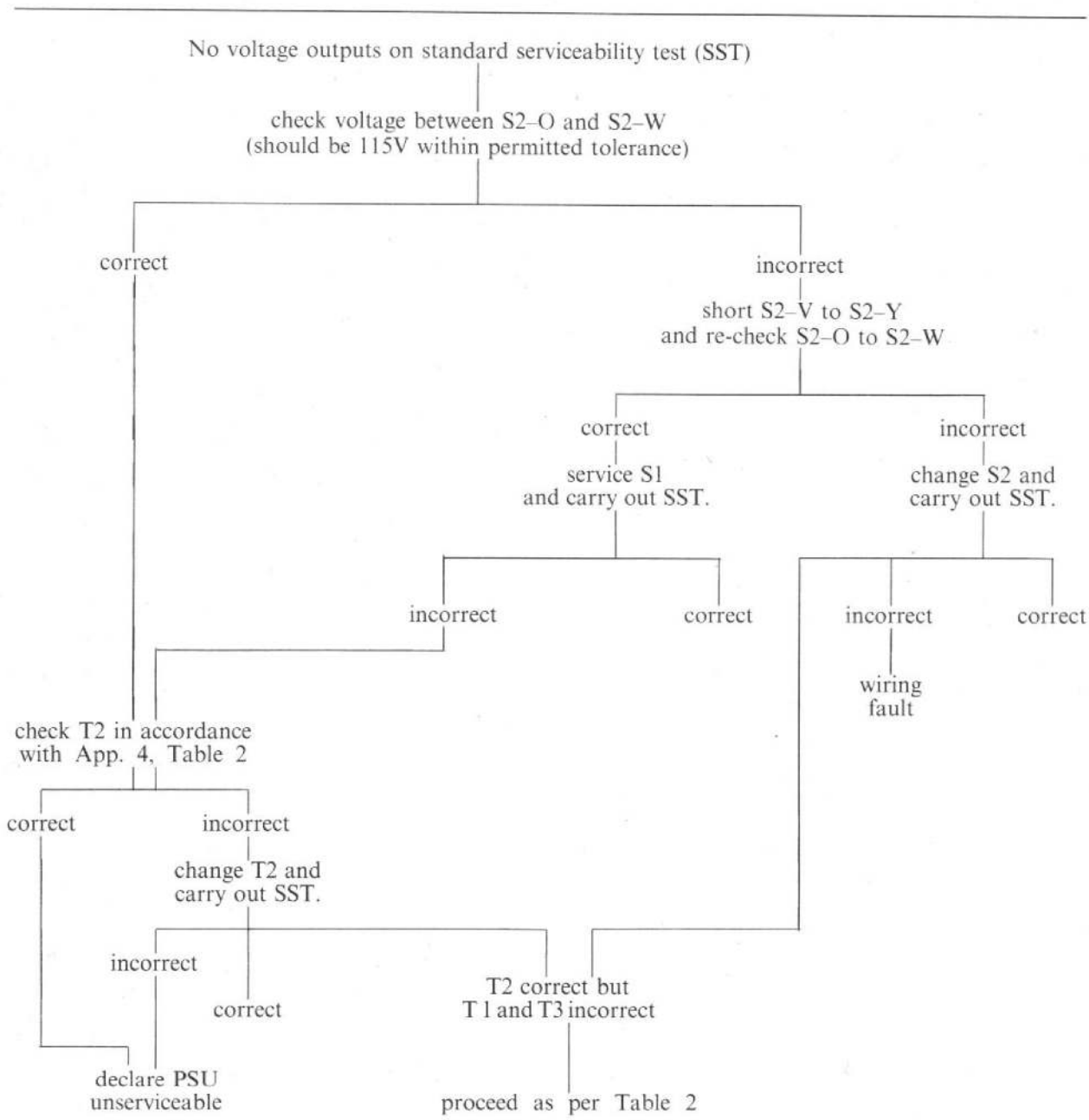

TABLE 2
Test sequence 2

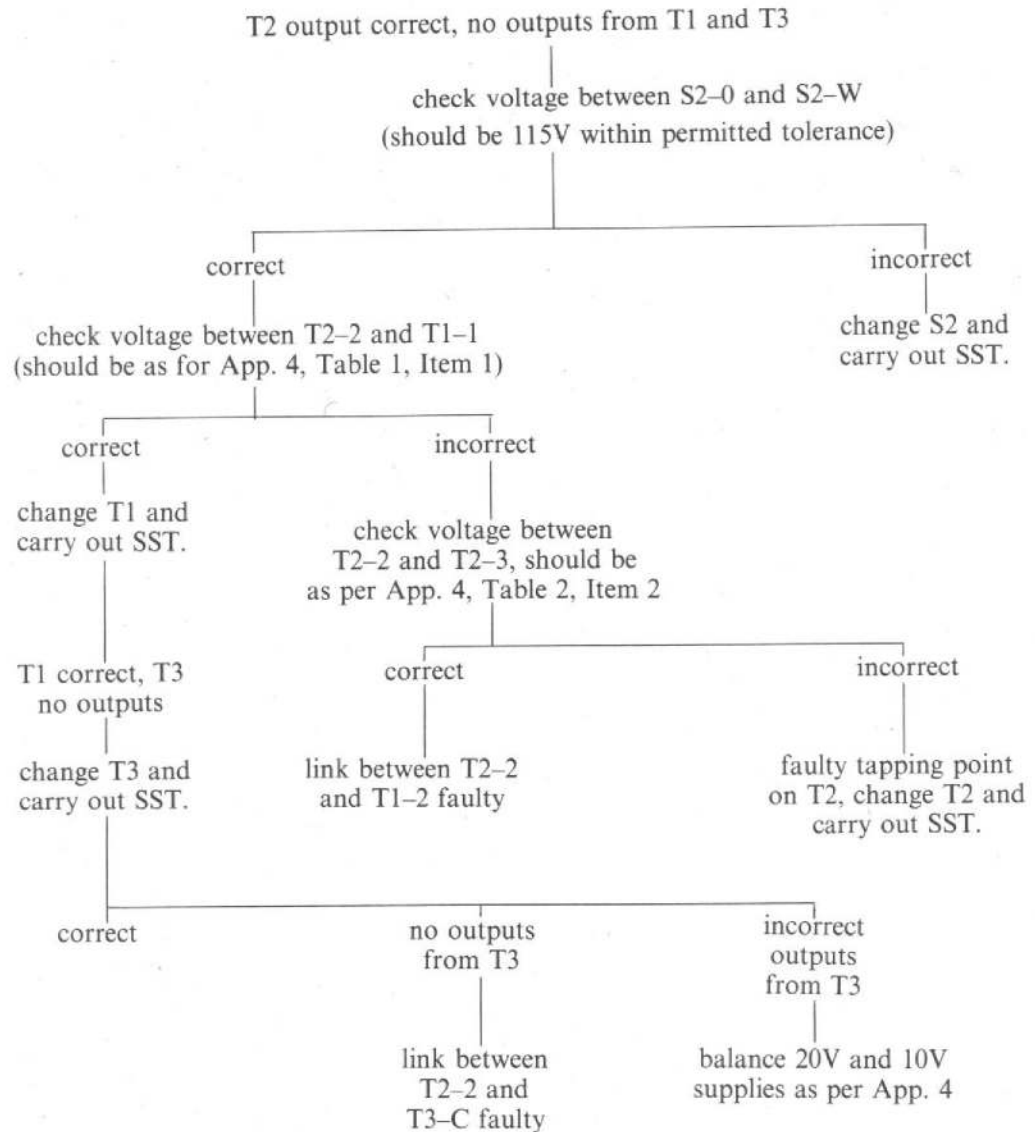

TABLE 3
Fault Summary

Item (a)	Symptom (b)	Possible faulty component(s) (c)	Action to be taken (d)
1	No voltage outputs	(a) S1 (b) S2 (c) T2	Carry out sequence of Table 1
2	T2 correct, no outputs from T1 or T3	(a) S2 (b) T1 and T3 (c) Link from T2 to T1 and T3	Carry out sequence of Table 2
3	D.C. voltages out of tolerance, 50V correct	(a) Faulty resistors/diodes/chokes/capacitors in relevant channel (b) T2	(a) Check output components as detailed in App. 4 (b) Change T2 and carry out SST.
4	50V out of tolerance, all other outputs correct	T2	Change T2 and carry out SST.
5	No T2 outputs; T1 and T3 correct	T2	Change T2 and carry out SST.
6	20V or 10V out of tolerance	(a) RV1 (b) RV3 and/or RV4 (c) T3	Check components and balances as detailed in App. 4, then carry out SST. Change T3 and carry out SST.
7	Any other a.c. voltages out of tolerance	T1	Change T1 and carry out SST.
8	All outputs out of tolerance	(a) T2 (b) T1, T2 and T3	Change and carry out SST. Check T3 output components and balance before replacing transformer

This file was downloaded from the RTFM Library.
Link: www.scottbouch.com/rtfm

Please see site for usage terms, and more aircraft documents.

