

Appendix 4

POWER SUPPLY UNIT, TYPE B, Ref. No. 6A/6822
and TYPE C, Ref. No. 6A/8548

SERVICING

TESTS AND ADJUSTMENTS

LIST OF CONTENTS

	<i>Para.</i>		<i>Para.</i>
<i>General</i>	1	<i>Capacitors</i>	16
<i>Wiring check</i>	8	<i>Chokes</i>	17
<i>Insulation test</i>	9	Balance of 20V and 10V supplies	18
<i>Power failure torque switch (S1)</i>	12	<i>Test set, Type 9</i>	20
<i>Fixed resistors R1 to R16</i>	13	<i>Test set, Type 9A</i>	29
<i>Pre-set resistors RV1, RV3 and RV4</i>	14	<i>Test set, Type 9B</i>	33
<i>Silicon diodes MR1 to MR14</i>	15	<i>Transformers</i>	37
		<i>Final check and switching off</i>	39

LIST OF TABLES

	<i>Table</i>
<i>Transformer T1 voltages</i>	1
<i>Transformer T2 voltages</i>	2

LIST OF ILLUSTRATIONS

	<i>Fig.</i>
<i>Setting up RV4 if both 10V(X) and 10V(Y) are out of tolerance (test set, Type 9)</i>	1
<i>Balancing 10V(X) and 10V(Y) if only one phase is out of tolerance (test set, Type 9)</i>	2

General

1. The tests detailed in this appendix are additional to the standard serviceability tests of App. 1 (R.A.F.) or App. 2 (R.N.) and are necessary when components are replaced (App. 5) or during fault diagnosis (App. 3).

2. All tests are to be performed with the power supply unit (PSU) connected to the test set, Type 9 or 9A, as shown in App. 1, or Type 9B as shown in App. 2 (with the exception of the tests of para. 8, 9 and 10) and the cover removed. The tests are applicable to units modified up to and including Mod. ADS/160.

3. Illustrations of the PSU and a circuit diagram are given in Chap. 9.

4. On adjustment or replacement of a faulty component, the PSU should be subjected to the relevant standard serviceability test to ensure that only this component is at fault.

5. The conditions under which servicing is to be carried out must be closely controlled regarding freedom from dust and dirt.

6. App. 1 and 2 list the abbreviations used in the relevant service for test equipment components. Test equipment additional to that listed in App. 1 and 2 is required as below:—

(1) Insulation resistance tester, Type C, Ref. No. 5G/152.

(2) Voltage divider box, 10 kilohm, 4 dial, to an accuracy of 0.1 per cent Ref. No. 6C/2352 or equivalent.

(3) 10 kilohm, 1W resistor Ref. No. 10W/0212128 (R.A.F. test set, Type 9 only).

(4) One 300 ohm, 10W resistor, $\pm 5\%$ (R.A.F., test set, Type 9 only).

(5) Plessey Mk 4, 25-way plug, position 0 (R.A.F. test set, Type 9 only), NATO No. 5935-99-056-0400.

RESTRICTED

7. In order to avoid confusion between pins on the PSU distribution panel and the Plessey connectors on the front panel, the latter will be referred to throughout this appendix by the nomenclature in brackets of Chap. 9, fig. 1. Distribution panel pins will be referred to by the nomenclature of Chap. 9, fig. 4a.

Wiring check

8. The point-to-point wiring should be checked to conform in detail to the circuit diagram (Chap. 9, fig. 6).

Insulation test

9. Remove the shorting links to the chassis by unsoldering all leads to the lugs, separate them one from another and ensure that they remain clear of all electrical connection. Using the insulation tester of para. 6, test the insulation resistance between each pin on SK2 and the chassis of the PSU. In each case the resistance should be greater than 10 megohm.

10. Replace all leads to the soldering lugs and check for continuity between SK2/F, PS6/G, RV1 wiper, T1/7 and chassis in each case.

11. Carry out the standard serviceability test of App. 1 or App. 2 as applicable.

Note . . .

Before any output tests are made, the 115V supply must have been switched to the PSU for at least 30 min.

Power failure torque switch (S1)

12. (1) Set PCU MAINS to OFF and disconnect the PSU from the test set.
- (2) Remove the torque switch from the PSU (App. 5).
- (3) Test and adjust the torque switch as detailed in A.P.4685, Vol. 1, Part 2, Sect. 1, Chap. 3.
- (4) Replace serviceable torque switch into the PSU and reconnect the PSU to the test set.
- (5) Carry out the power failure torque switch tests as detailed in App. 1 or App. 2.

Fixed resistors R1 to R16

13. All fixed resistors can be tested in position by unsoldering one end connection and applying the multimeter of App. 1 or 2, set to the correct range, across the resistor leads. Values and tolerances are given in App. 5, Table 4.

Preset resistors RV1, RV3 and RV4

14. Each of the preset resistors is tested with the multimeter of App. 1 or 2, set to the correct range. All connections to RV1 must be broken before testing. RV3 and RV4 can be tested whilst in circuit, but the power must be switched off. Values and tolerances are given in App. 5, Table 4.

Silicon diodes MR1 to MR14

15. These should be tested with the insulation tester. Unsolder one end of the diode and connect the insulation tester across it, first in one direction then in the other. Forward resistance should be less than 1000 ohm, reverse resistance greater than 500 megohm.

Capacitors

16. If a capacitor in any of the d.c. output circuits of transformer T2 is suspect it should be tested, using normal workshop methods with the insulation tester of App. 1 or 2.

Chokes

17. (1) Disconnect pin H of a suspect choke.
- (2) Using the multimeter of App. 1 or 2, set to the ohms range, check the choke for continuity from pin A to pin H.
- (3) Using the insulation tester of App. 1 or 2, measure the insulation resistance between each pin of the choke and the chassis of the PSU. In each instance this should be greater than 10 megohm.

BALANCE OF 20V AND 10V SUPPLIES

18. The 20V(X) and (Y) supplies are balanced by the adjustment of RV1; the 10V supplies by the adjustment of RV3 and/or RV4.

19. The procedure depends upon the type of test set in use and has therefore been detailed separately for each type.

Test set, Type 9

20V supplies

20. (1) Carry out the preparation and power failure torque switch tests as detailed in App. 1.
- (2) Adjust RV1 to bring the valve voltmeter to a reading of not more than 10mV.
- (3) Carry out the 20V output tests as detailed in App. 1.
- (4) Repeat sub-para. (2) and (3) as necessary until the results obtained are within tolerance.

21. If the conditions of para. 20 cannot be satisfied, check the values of R15, R16 and RV1 (para. 13 and 14). Replace if necessary and repeat para. 20. If the resistors are within tolerance or, having been changed, the conditions of para. 20 still cannot be satisfied, replace transformer T3 and repeat para. 20.

10V supplies

22. The 10V supplies must be adjusted so that the voltage outputs from RV3 and RV4 are equal, within permitted tolerances, to one another and to 0.0954 of the primary voltage of transformer T3. If only one phase is out of tolerance, therefore, it is sufficient to adjust the relevant pre-set potentiometer to bring both phases into balance.

23. In order to carry out this balancing the primary voltage of T3 must be isolated from earth. This can be achieved in one of two ways, either by (a) isolating phase B of the 115V supply to the PCU or (b) disconnecting the PSU from the test set, Type 9 and feeding 115V phase A and C to terminals 1 and 2 respectively of transformer T1. (As transformer T1 and T3 primaries are connected in parallel, this automatically ensures 115V phase A and C to terminals B and C of T3. The supply is made this way as T1 is more accessible than T3.)

24. On many R.A.F. stations method (a) will be impracticable; it will therefore be discounted and method (b) adopted.

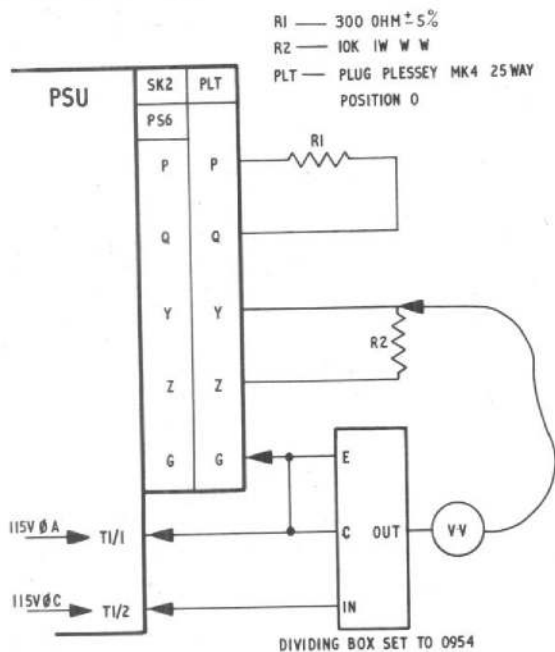

Fig. 1. Setting up RV4 if both 10V(X) and 10V(Y) are out of tolerance (test set, Type 9)

Both 10V phases out of tolerance

25. (1) Switch off S1A and PCU MAINS and disconnect the PSU from test set, Type 9.
- (2) Connect up subsidiary test equipment as shown in fig. 1, with pin 1 of transformer T1 connected to pin A of SK9 (PS3) of the distribution panel of test set, Type 9 and pin 2 of transformer T1 connected to pin C of the same socket.
- (3) Switch on PCU MAINS and S1A.
- (4) Set the dividing box to 0954 and adjust RV4 until the valve voltmeter registers a null.
- (5) Adjust the dividing box in each direction in turn to a point where the valve voltmeter reading just starts to increase; if RV4 has

been adjusted correctly, this should be achieved by a movement of the dividing box control of not more than 0001 each way.

- (6) Repeat sub-para. (4) until the terms of sub-para. (5) have been satisfied.
- (7) Switch off S1A and PCU MAINS, disconnect subsidiary test equipment, with the exception of T1, and reconnect as shown in fig. 2.
- (8) Switch on PCU MAINS and S1A, set the dividing box to 5000 and adjust RV3 until the valve voltmeter registers a null.
- (9) Adjust the dividing box in each direction to a point where the valve voltmeter reading just starts to increase; if RV3 has been adjusted correctly, this should be achieved by a movement of the voltage dividing box control of not more than 0005 each way.
- (10) Repeat sub-para. (8) until the terms of sub-para. (9) have been satisfied.
- (11) Switch off S1A and PCU MAINS, disconnect subsidiary test equipment and T1 and reconnect the PSU to the test set, Type 9.
- (12) Carry out the standard serviceability output tests in respect of 10V(X) and 10V(Y).
- (13) Repeat as necessary from sub-para. (1) until both supplies are within tolerance.

26. If the conditions of para. 25 (6), (10) and (13) cannot be satisfied, check the values of RV3 and RV4. Replace if out of tolerance and repeat para. 25. If these resistors are within tolerance or, having been replaced, the conditions of para. 25 still cannot be satisfied, replace transformer T3 and repeat from para. 20.

One 10V phase only out of tolerance

27. (1) Switch off S1A and PCU MAINS and disconnect the PSU from the test set, Type 9.
- (2) Connect up subsidiary test equipment as shown in fig. 2, with pin 1 of transformer T1 connected to pin A of SK9 (PS3) of the distribution panel of test set, Type 9 and pin 2 of transformer T1 connected to pin C of the same socket.
- (3) Switch on PCU MAINS and S1A.
- (4) Set the dividing box to 5000 and, if X phase is out of tolerance, adjust RV4 or, if Y phase is out of tolerance, adjust RV3 until the valve voltmeter registers a null.
- (5) Adjust the dividing box in each direction in turn to a point where the valve voltmeter

reading just starts to increase; if the potentiometer has been adjusted correctly this should be achieved by a movement of the voltage dividing box control of not more than 0005 each way.

(6) Repeat sub-para (4) until the terms of sub-para. (5) have been satisfied.

(7) Switch off S1A and PCU MAINS, disconnect subsidiary test equipment and T1 and reconnect the PSU to the test set, Type 9.

(8) Carry out the standard serviceability output voltage tests in respect of the 10V supplies.

(9) Repeat as necessary from sub-para. (1) until the adjusted supply is within tolerance.

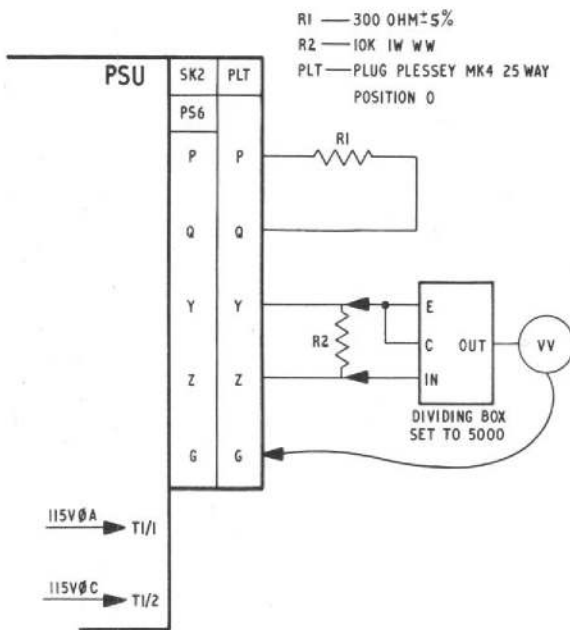

Fig. 2. Balancing 10V(X) and 10V(Y) if only one phase is out of tolerance (test set, Type 9)

28. If the conditions of para. 27 cannot be satisfied check the value of the preset potentiometer being adjusted. Replace if necessary and repeat para. 27. If the potentiometer is within tolerance or, having been changed, the conditions of para. 27 still cannot be satisfied, change transformer T3 and repeat from para. 20.

Test set, Type 9A

Balance of 20V supplies

29. (1) Carry out the relevant preparation and power failure torque switch test of App. 1.

(2) Set PCU MAINS, S1 and S11 to ON, S4 (VOLTAGE SELECT) to OFF, S3 (SOCKET SELECT) to PS6, S9 to 20V BALANCE, and S28 to EXT. UNITS.

(3) With S5 set to the position giving the greatest accuracy, hold S10 in the 20V BAL PSU position and adjust RV1 to produce the lowest possible reading below $\pm 10\text{mV}$ on M3.

(4) Carry out the standard serviceability output voltage tests in respect of 20V(X) and 20V(Y).

(5) Repeat from sub-para. (2) as necessary until the readings of sub-para. (4) are within tolerance.

30. If the conditions of para. 29 cannot be satisfied check the values of R15, R16 and RV1 (para. 13 and 14). Replace as necessary and repeat para. 29. If the resistors are within tolerance or, having been changed, the conditions of para. 29 still cannot be satisfied, replace transformer T3 and repeat para. 29.

Balance of 10V supplies

31. (1) Set PCU MAINS, S1 and S11 to ON, S4 (VOLTAGE SELECT) to OFF, S3 (SOCKET SELECT) to PS6, S9 to 9V BALANCE, and S28 to EXT. UNITS.

(2) With S5 set to the position giving the greatest accuracy, adjust RV3 and/or RV4 to produce the lowest possible reading below $\pm 10\text{mV}$ on M3.

(3) Carry out the standard serviceability output voltage tests in respect of 10V(X) and 10V(Y).

(4) Repeat from sub-para. (1) as necessary until the readings specified in sub-para. (3) are within tolerance.

32. If the conditions of para. 31 cannot be satisfied check the values of RV3 and RV4 (para. 14) and replace if out of tolerance. Repeat para. 31. If the potentiometers are within tolerance or, having been changed, the conditions of para. 31 still cannot be satisfied, change transformer T3 and repeat from para. 29.

Test set, Type 9B

Balance of 20V supplies

33. (1) Carry out the preparation and power failure torque switch test of App. 2.

(2) Set PCU MAINS and S1 to ON, S8 (SOCKET SELECT) to PS6, S9 (VOLTAGE SELECT) to OFF, S14 to BALANCE, and S15 to $\times 100$.

(3) Adjust RV1, setting S15 to successively lower ranges as necessary until meter M3 registers the lowest possible null below $\pm 10\text{mV}$.

(4) Carry out the standard serviceability output test in respect of 20V(X) and 20V(Y).

(5) Repeat as necessary from sub-para. (1) until both 20V(X) and 20V(Y) are within the tolerances of App. 2, Table 2.

34. If the conditions of para. 33 cannot be satisfied, then check the values of R15, R16 and RV1 (para. 13 and 14), replace as necessary and repeat para. 33. If the resistors are within tolerance or, having been changed, the conditions of para 33 still cannot be satisfied, then change transformer T3 and repeat para. 33.

Balance of 9.5V supplies

35. (1) Set PCU MAINS and S1 to ON, S8 (SOCKET SELECT) to PS6, S9 (VOLTAGE SELECT) to 9.5V(X).

(2) Adjust RV4 to give a reading on meter M1 as near as possible to 9.5V.

(3) Set S9 to OFF, S14 to 9.5V BAL and S15 to $\times 100$.

(4) Adjust RV3, setting S15 to successively lower ranges as necessary until meter M3 registers the lowest possible null below $\pm 10\text{mV}$.

(5) Carry out the standard serviceability output test in respect of 9.5V(X) and 9.5V(Y).

(6) Repeat as necessary from sub-para. (1) until the conditions of sub-para. (2) and (4) and the tolerances of the standard serviceability output test have all been satisfied.

36. If the conditions of para. 35 cannot be satisfied, check the values of RV3 and RV4 (para. 14), and replace if out of tolerance. Repeat

para. 35. If the potentiometers are within tolerance or, having been changed, the conditions of para. 35 still cannot be satisfied, change transformer T3 and repeat from para. 33.

Transformers

37. Voltages at the various terminals of transformers T1 and T2 can be tested using the multi-meter of App. 1 and 2 set to the appropriate range. Values and permitted tolerances are given in Table 1 and 2 respectively.

38. The terminals of transformer T3 are inaccessible, and therefore it cannot be tested in position. Reference should be made to the appropriate 20V and 10V balance checks, dependent upon the type of test set in use.

Final check and switching off

39. (1) Switch off supply to PSU.

(2) Replace PSU cover and carry out standard serviceability test.

(3) Set all switches and simulators on the test set to the off, normal or zero position and disconnect the PSU from the test set.

(4) Lightly smear plug and socket threads of the PSU with silicone compound MS4, Ref. No. 33H/9424829.

TABLE 1
Transformer T1 voltages

Item (a)	Terminals (b)	Voltages (c)	Tolerance (volts) (d)
1	1 to 2	99.6	87.86 to 101.33
2	3 to 4	86.5	82.1 to 90.875
3	5 to 4	86.5	82.1 to 90.875
4	6 to 7	25.7	24.5 to 27.0
5	9 to 8	8.2	7.8 to 8.6
6	13 to 14	6.1	5.8 to 6.4
7	15 to 17	6.1	5.8 to 6.4

TABLE 2
Transformer T2 voltages

Item (a)	Terminals (b)	Voltages (c)	Tolerance (volts) (d)
1	1 to 2	57.5	56.5 to 58.5
2	2 to 3	57.5	56.5 to 58.5
3	1 to 3	115.0	113.0 to 117.0
4	4 to 5	50.0	48.0 to 52.0
5	6 to 7	8.9	8.45 to 9.35
6	8 to 7	8.9	8.45 to 9.35
7	9 to 10	27.5	25.6 to 28.4
8	11 to 12	11.0	10.45 to 11.55

RESTRICTED

This file was downloaded
from the RTFM Library.
Link: www.scottbouch.com/rtfm

Please see site for usage terms,
and more aircraft documents.

