

**B.R.1771(12)**

**COMMON NAVAL RADIO**

**TEST EQUIPMENT**

**Handbook for**

**A.P. 67166**

**NOISE GENERATOR**

**CT 82.**

( JOINT-SERVICES DESIGNATION:  
NOISE GENERATOR CT82 )

ANY SUGGESTIONS FOR AMENDMENTS OR ADDITIONS TO THIS BOOK  
SHOULD BE SUBMITTED TO THE CAPTAIN SUPERINTENDENT, A.S.R.E.,  
THROUGH THE USUAL CHANNELS



RADIO EQUIPMENT DEPARTMENT · ADMIRALTY.  
OCT. 1957 (R.E. 633/54)



### AMENDMENT RECORD SHEET

Incorporation of an Amendment List in this publication is to be recorded by signing in the appropriate column and inserting the date of making the amendments.

A.L. No	AMENDED BY	DATE
1	Incorporated in this issue	—
2		
3		
4		
5		
6		
7		
8		
9		
10		
11		
12		
13		
14		
15		
16		
17		
18		
19		
20		
21		
22		
23		
24		
25		
26		
27		

A.L. No.	AMENDED BY	DATE
28		
29		
30		
31		
32		
33		
34		
35		
36		
37		
38		
39		
40		
41		
42		
43		
44		
45		
46		
47		
48		
49		
50		
51		
52		
53		
54		

A.L. No.	AMENDED BY	DATE
55		
56		
57		
58		
59		
60		
61		
62		
63		
64		
65		
66		
67		
68		
69		
70		
71		
72		
73		
74		
75		
76		
77		
78		
79		
80		
81		
82		
83		
84		
85		

A.L. No.	AMENDED BY	DATE
86		
87		
88		
89		
90		
91		
92		
93		
94		
95		
96		
97		
98		
99		
100		
101		
102		
103		
104		
105		
106		
107		
108		
109		
110		
111		
112		
113		
114		
115		
116		

ADMIRALTY, S. W. 1.

OCTOBER, 1957.

R. E. 633/54.

B. R. 1771(12) "Handbook for A. P. 67166 Noise Generator CT82" having been approved by My Lords Commissioners of the Admiralty, is hereby promulgated.

B. R. 1771(12) Handbook for A. P. 67166 Noise Generator CT82, 1954 is hereby superseded and copies should be disposed of in accordance with instructions in B. R. 1.

By Command of Their Lordships

---

To:-  
Flag Officers and  
Commanding Officers  
of H. M. Ships and  
Vessels concerned.



**A.P.67166 NOISE GENERATOR, (15 kc/S - 100 MC/S), CT82**

(Joint-Service Designation:- Noise Generator, CT82)

**SUMMARY OF DATA**

**PURPOSE**

Measurement of noise factor of wireless receiving equipment, metric radar receivers and radar wide-band I.F. amplifiers, in the band 15 kc/s - 100 Mc/s.

**BRIEF DESCRIPTION**

It is a portable instrument, (together with box, stowage, for flexible connectors and adaptors) suitable for servicing receivers in situ. Essentially the instrument consists of a pair of saturated diodes whose anode current fluctuations through a load resistor provides the output noise power; the noise output is controlled by altering the filament current of the diodes. Output matching arrangements are provided. The instrument includes a separate audio power meter for measuring output of communications receivers. The output meter is calibrated in decibels with respect to a purely arbitrary power reference-level.

**PERFORMANCE**

Frequency Coverage - 15 kc/s - 100 Mc/s.  
 Output Impedance - 43, 75 or 400 ohms.  
 Noise Factor Meter (Diode Current).

The following scales are provided:-

- 0 to 10 mA or 0 to 100 mA by switch.
- 43 ohms noise factor scale 0 to 9 dB.
- 75 ohms noise factor scale 0 to 11 dB.
- 400 ohms noise factor scale 0 to 4 dB.
- (10 dB is added when switch is at "100 mA")

Audio Power Output Meter Calibrated 0 to 16 dB. Switch provides high, medium or low input impedance.

**POWER REQUIREMENTS**

115, 180, 200, 210, 220, 230, 240, 250V, 50 to 500 c/s single phase.  
 50W (approx.)

**PHYSICAL DATA**

A.P.67166 Noise Generator	<u>HEIGHT</u> 9½"	<u>WIDTH</u> 11"	<u>DEPTH</u> 8¼"	<u>WEIGHT</u> 21 lb
A.P.60875A Box of Flexible Connectors	<u>HEIGHT</u> 8"	<u>WIDTH</u> 4½"	<u>LENGTH</u> 10½"	<u>WEIGHT</u> 3½ lb

**HANDBOOK**

B.R.1771(12)

**ESTABLISHMENT LIST**

E.1115

**PRODUCTION SPECIFICATION**

14142.



NOISE GENERATOR CT82

NOVEMBER 1957

ISSUE NO. 2

NOISE GENERATOR CT82



H A N D B O O K   F O R  
A . P . 6 7 1 6 6   N O I S E   G E N E R A T O R   C T   8 2

LIST OF CONTENTS

SUMMARY OF DATA

PART 1 :	CHAPTER 1	-	INTRODUCTION
	CHAPTER 2	-	TECHNICAL DESCRIPTION
PART 2 :	CHAPTER 1	-	OPERATING INSTRUCTIONS
	CHAPTER 2	-	MAINTENANCE
APPENDIX 'A'	-		THE EFFECT OF NOISE ON RADIO COMMUNICATION
APPENDIX 'B'	-		THE THEORY OF NOISE FACTOR MEASUREMENT
APPENDIX 'C'	-		NOISE GAIN AND ITS USE AS A MEASURE OF COMMUNICATION RECEIVER PERFORMANCE.



# **PART 1**

## **CHAPTER 1**



### **INTRODUCTION AND CONTROLS**

## **CHAPTER 2**



### **TECHNICAL DESCRIPTION**

CHAPTER 1

INTRODUCTION

LIST OF CONTENTS

	<u>Paragraph</u>
Function of Instrument	1-8
Electrical Specification	9
Panel Controls, Switches, Meters, etc.	10

LIST OF DIAGRAMS

Diagram 1.1 - View of Panel



To avoid conflict with drawings previously issued, some non-standard coded references of components have been retained.

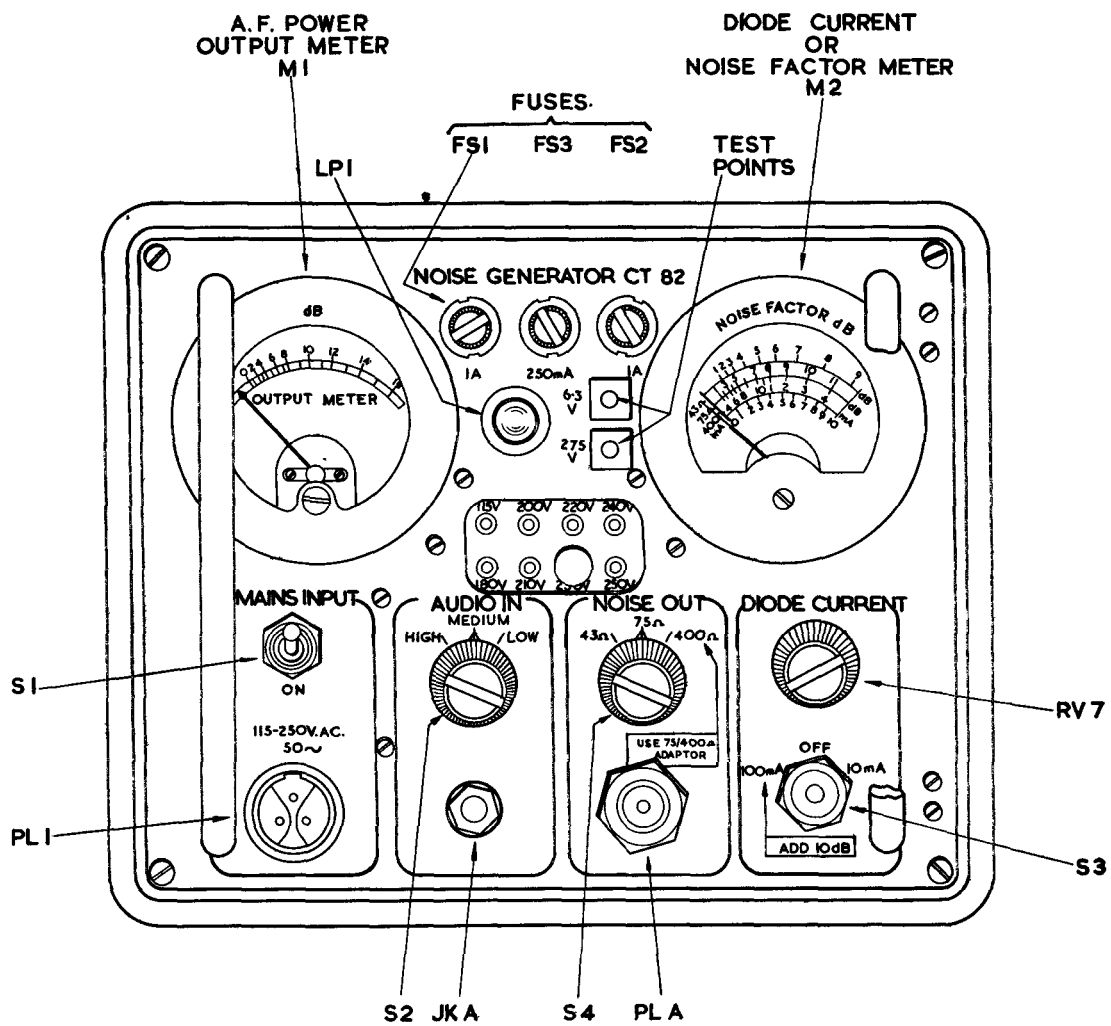

DIAG I.I VIEW OF PANEL

CHAPTER 1INTRODUCTIONFunction of Instrument

1. A loss of sensitivity in a radar or communication receiver may be caused by an increase in the noise level of the valves or components within the receiver after installation, which will reduce the signal-to-noise ratio of the receiver.
2. Since the valves and components may deteriorate after a period of time, it is necessary to measure the noise factor of the receiver at regular intervals. This measurement may be performed either with a signal generator and output meter or with a noise generator and output meter.
3. The method using a signal generator for the measurement of noise factor is long and tiresome; also, signal generators are usually large and cumbersome. It would be difficult, therefore, to check a large number of receivers, distributed around an aircraft carrier or cruiser, using a signal generator. Some advantages and disadvantages of a noise generator are given at the end of Appendix 'B'.
4. Noise Generator CT 82 is a light portable instrument designed to simplify the measurement of noise factor of receivers, within the frequency range 15 kc/s to 100 Mc/s. It contains a noise-generating circuit and an a. f. power measuring circuit.
5. The noise-generating circuit provides an r. f. noise-signal of adjustable power. The a. f. power measuring circuit is used when the noise factor of a communication receiver is being measured; when the noise factor of a metric radar receiver or a wide-band i. f. amplifier is being measured, the second-detector current meter is used as an output meter.
6. While the noise factor gives a quantitative indication of the noise generated internally in a receiver, a full appraisal of the receiver performance cannot be made without a knowledge of the overall gain.
7. When the controls of a receiver are set to predetermined positions, with gain controls at maximum, the noise-power output from the receiver depends mainly upon two factors:-
  - (a) the noise generated within the receiver
  - (b) the overall gain of the receiver.
8. If the noise is shown to be normal by means of a noise factor check, any abnormality in the value of the noise-power output is due to an abnormal value of receiver gain. (For a more detailed discussion of this subject, including the use of the Noise Generator, see Appendix 'C'.)

Electrical Specification

9. For a brief electrical specification see the Summary of Data.

Panel Controls, Switches, Meters, Etc.

10. (a) MAINS INPUT Plug (PL1)

Mains supply is applied to the instrument via this plug.

(b) MAINS INPUT Switch (S1)

Mains on-off switch.

(c) Mains Voltage Selector Panel

The small plug is inserted in the socket appropriate to the voltage of the mains supply.

(d) AUDIO IN Jack (JKA)

The a. f. output of the (communication) receiver under test is applied to the instrument via this jack.

(e) AUDIO IN Switch (S2)

Three available positions enable selection of HIGH, MEDIUM, or LOW input impedance of the a. f. power measuring circuit to be made, in order to match approximately the output impedance of the (communication) receiver under test. This switch is often used in conjunction with the a. f. gain control of the receiver to give a convenient reading (e. g. 10dB) on the OUTPUT METER.

(f) NOISE OUT Switch (S4)

Three available positions enable selection of 43 ohms, 75 ohms, or 400 ohms output impedance of the noise-generating circuit to be made, in order to match this circuit of the input circuit of the receiver under test. The 400 ohms position is always used in conjunction with a special adaptor.

(g) NOISE OUT Plug (PLA)

Noise-power output is fed from this plug to the equipment under test, via an appropriate connector (and adaptor, if necessary).

(h) DIODE CURRENT Control (RV7)

A variable resistor controlling the magnitude of the noise-power output; it is situated in the filament circuit of the noise diodes.

(j) DIODE CURRENT Switch (S3)

Three positions are provided; these are 100 mA, OFF, and 10 mA.

(k) Fuses (FS1, FS2, FS3)

Three fuses are provided:- two 1A mains fuses and one 250 mA h. t. fuse.

(l) Lamp (LP1)

Indicates whether or not the mains supply is reaching the mains transformer.

(m) Test Sockets (SK1, SK2)

6.3V a. c. and 275V d. c. test sockets are provided.

(n) OUTPUT METER (M1)

This meter is calibrated in decibels with respect to an arbitrary power reference-level, and is used to measure ratios of a. f. power output of the (communication) receiver under test.

(o) NOISE FACTOR Meter (M2)

This meter measures the anode current of the noise diodes and is calibrated in milliamps. It is also calibrated in decibels, representing noise factor; a separate noise-factor scale is provided for each value of output impedance (i. e. 43 ohms, 75 ohms, 400 ohms).



CHAPTER 2

TECHNICAL DESCRIPTION

LIST OF CONTENTS

	<u>Paragraph</u>
Simplified Noise-Generating Circuit	1-6
Complete Noise Generator Circuit	7-15
NOISE FACTOR MEASUREMENT	
General	16-21
Communication Receivers	22-23
Radar Receivers	24-25
Alternative Method	26-27
Note	28-29

LIST OF DIAGRAMS

Diagram 2.1	-	Simplified Noise-Generating Circuit
Diagram 2.2	-	Typical Diode Characteristics



CHAPTER 2TECHNICAL DESCRIPTIONSimplified Noise-Generating Circuit

1. Diagram 2.1 is a simplified version of the noise-generating circuit; the component references correspond to those in the complete circuit diagram, Fig. 1, Part 2.

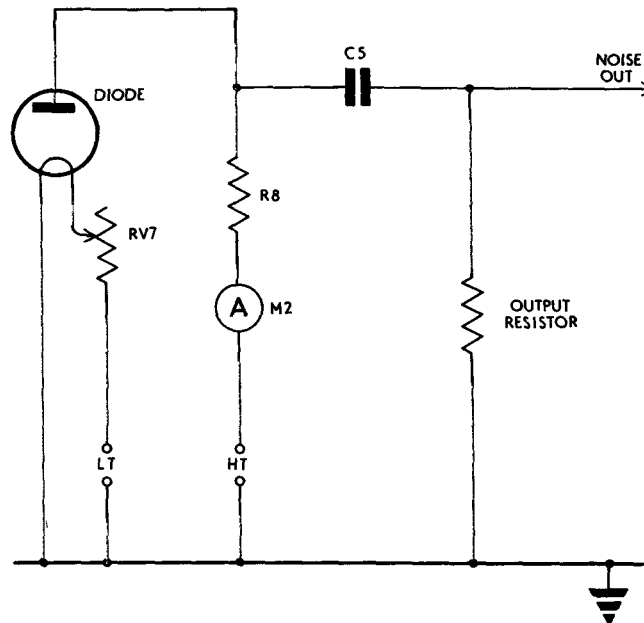

DIAG.2.1 SIMPLIFIED NOISE-GENERATING CIRCUIT

2. The filament of the diode is heated by current from a low-voltage a. c. source. Variable resistor RV7 enables the value of the filament current (and therefore the emission available from the filament) to be adjusted.
3. The diode anode current is measured by the milliammeter M2. The anode voltage is sufficiently high to ensure that the diode is always operated in the temperature-limited condition; see Appendix 'B' Para. 10. The magnitude of the anode current is therefore dependent upon the emission available from the filament and is thus controlled by means of RV7.
4. Minute random fluctuations of anode current occur and these form the noise-current output of the diode; see Appendix 'B' Para. 11. The diode thus acts as a generator of a noise-current of constant r. m. s. value, provided that the anode current (i. e. the mean or d. c. value, as indicated on M2) remains constant and that a given bandwidth is considered.
5. Virtually the whole of the noise current flows through the output resistor via capacitor C5, since the impedance of the alternative path through resistor R8 is comparatively high. Hence the noise power generated by the diode is dissipated in the output resistor. However, if a load (e. g. a receiver) is connected across the latter, some of the noise current flows through the circuit thus formed and noise power is dissipated in the load.

6. Typical characteristic curves of a diode suitable for use in the noise-generating circuit are given in Diagram 2.2. The temperature-limited condition of the diode is shown on the right-hand side of the diagram.

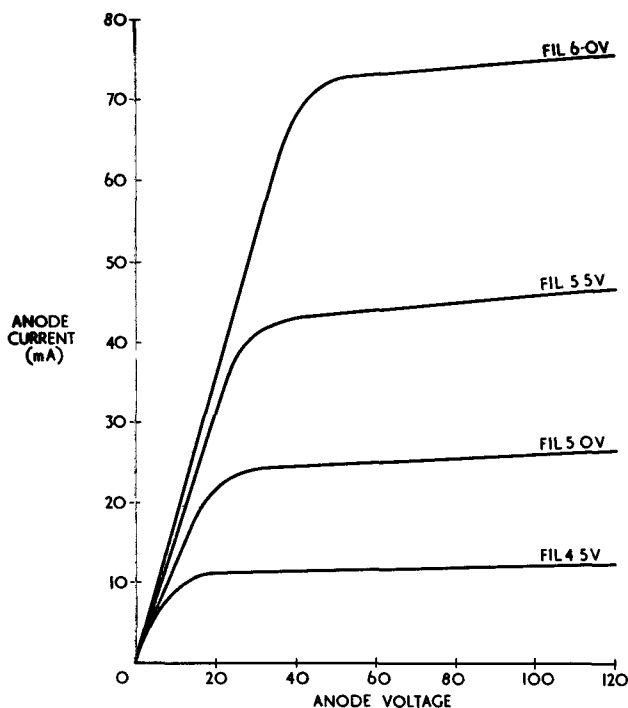

DIAG.2.2 TYPICAL DIODE CHARACTERISTICS

### Complete Noise Generator Circuit

7. Figure 1 shows the complete Noise Generator circuit, the noise-generating portion being fundamentally the same as Diagram 2.1.
8. Two diodes V2 and V3 (both CV2398) are used in order to provide adequate noise; they are connected in parallel. Their filaments are supplied from a 6.3V winding on the mains transformer TR1 via variable resistor RV7 (DIODE CURRENT control).
9. The 275V h.t. supply is provided by a conventional full-wave rectifier circuit; rectifier valve V1 (CV493) derives the necessary a.c. voltages from transformer TR1, the output from V1 being passed through a choke-input filter consisting of choke L1 and capacitors C2, C3.
10. The anodes of the diodes are connected to the h.t. supply via anode load resistor R8 and milliammeter M2 (NOISE FACTOR meter), while capacitor C4 provides the decoupling. Fundamentally, the NOISE FACTOR meter measures d.c. current, but it is calibrated in decibels (representing noise factor) in addition to milliamps. The DIODE CURRENT switch S3 has three positions; the 100 mA and 10 mA positions give the NOISE FACTOR meter a full scale deflection of the value stated, while in the OFF position the NOISE FACTOR meter is out of circuit and the h.t. line open-circuited.

11. The noise output from the diodes is passed via capacitor C5 to the output resistor and the NOISE OUT plug PLA. The NOISE OUT switch S4 has three positions (43 ohms, 75 ohms and 400 ohms), thus permitting approximate matching to the input impedance of the receiver or other equipment under test. The output resistor (R11) for the 43 ohms position is 50 ohms, whereas the same output resistor (R10) of 82 ohms is used in both the 75 ohms and the 400 ohms positions. When matching to 400 ohms is required, an external adaptor (containing the appropriate impedance matching circuit) must be used. A variety of connectors and adaptors is provided in a separate box (see Fig. 7), and practical examples of their selection are given in Part 2 Chapter 1; they link the NOISE OUTPUT plug to the equipment under test.
12. The mains transformer TR1 is designed to accommodate any likely mains supply voltage at frequencies between 50 and 500 c/s. Three fuses are provided, one in each mains line (FS1, FS2) and one (FS3) between the centre tap of the h.t. secondary and the chassis. An indicating lamp (LP1), in series with resistors R3-R4, is connected across a 6.3V secondary, and shows whether or not the mains supply is reaching transformer TR1. Test sockets (SK1, SK2) are provided to facilitate the checking of the l.t. and h.t. voltages.
13. The Noise Generator also contains an a.f. power measuring circuit which is entirely separate, electrically, from the noise-generating circuit. The measuring circuit is built into the instrument for convenience, and is used in conjunction with the noise-generating circuit for testing communication receivers.
14. The receiver a.f. output is fed to the transformer TR2 via AUDIO IN jack JKA and AUDIO IN switch S2. The latter enables selection of HIGH, MEDIUM, or LOW input impedance to be made, thus providing an approximate match for the a.f. output circuit of the receiver.
15. The output from transformer TR2 is applied to microammeter M1 (OUTPUT METER) after rectification by bridge rectifier MR1. The OUTPUT METER is calibrated in decibels with respect to a purely arbitrary power reference-level, this reference-level being different for each position of the AUDIO IN switch. Hence this meter can be used to measure power ratios, but not actual values of power.

### NOISE FACTOR MEASUREMENT

#### General

16. The methods of measurement of noise factor are given in detail in Part 2 Chapter 1; only the main features of the technique are given in the following paragraphs. The latter contain several formulae, the derivations of which are given in Appendix 'B'. (Appendix 'A' is a technical account of the effect of noise on radio communication, while Appendix 'C' deals with noise gain and its use as a measure of communication receiver performance).
17. Basically, noise factor measurement is carried out as follows:-
- (1) Connect the Noise Generator to the receiver under test.
  - (2) With no diode anode current, adjust the noise-power output from the receiver to a convenient level.

- (3) Increase the diode anode current until the noise-power output from the receiver is double the original value.
  - (4) Measure the diode anode current (I amps).
  - (5) Calculate the noise factor from the formula  $10 \log_{10} 20IR$ , where R ohms is the value of the Noise Generator output impedance. The formula quoted gives the noise factor in decibels.
18. In Paragraph 17, it is assumed that the receiver gain and detection are linear. The noise-power output could be multiplied by a factor other than two, but this would necessitate the use of a slightly different noise factor formula; in practice, power doubling is found to be convenient.
19. In order to dispense with the need for a calculation every time a noise factor measurement is made, the Noise Generator NOISE FACTOR meter has been calibrated in decibels (representing noise factor) as well as milliamps. As the Noise Generator is designed to work as a source having an output impedance of 43, 75, or 400 ohms, a separate noise-factor scale is provided for each of these impedances.
20. When the DIODE CURRENT switch is in the 10 mA position, noise factors corresponding to diode anode currents up to 10 mA can be obtained direct from the relevant noise-factor scale on the NOISE FACTOR meter; in the case of the noise-factor scale relating to an impedance of 400 ohms, the left-hand portion (i. e. 4-6-8-10) should be ignored.
21. When the DIODE CURRENT switch is in the 100 mA position, the current reading on the NOISE FACTOR meter must be multiplied by 10. Noise factors corresponding to diode anode currents of 10 mA to 100 mA can be obtained by adding 10 dB to the reading on the relevant noise-factor scale, except in the case of the left-hand portion (4-6-8-10) of the scale relating to an impedance of 400 ohms, which should be read direct. (The noise-power output from the Noise Generator is directly proportional to the diode anode current. Hence, when the anode current is increased to ten times its former value, the noise-power output increases in the same proportion - which is equivalent to an increase of 10 dB).

### Communication Receivers

22. When measuring the noise factor of a communication receiver, the output from the receiver is measured on the Noise Generator OUTPUT METER. This meter is calibrated in dB with respect to a purely arbitrary reference-level, and is thus capable of the measurement of power ratios only. Initially, the OUTPUT METER is set to some convenient reading by adjustment of the receiver gain. An increase in OUTPUT METER reading of 3 dB indicates that the receiver power output is double the original value.
23. It is assumed in Para. 22 that the characteristic of the second detector of a communication receiver is linear. This is not usually so when the r. f. input is low; however, if the b. f. o. is switched on, the sweep over the characteristic is altered and the detector becomes linear, or very nearly linear.

Radar Receivers

24. When measuring the noise factor of a radar receiver, the output from the receiver is measured using the second-detector current meter. Initially, this meter is set to some convenient reading by adjustment of the receiver gain. A doubling of the noise-power output is indicated by an increase in second-detector current to  $\sqrt{2}$  (i. e. 1.41) times its original value.
25. It is assumed in Para. 24 that the characteristic of the receiver second detector is linear. If the characteristic is not linear, but is known, it is still possible to measure the noise factor by the power-doubling method. In this case, the power-doubling must take place at the detector input, although actual measurement of the output-power ratio corresponding to this condition is made at the detector output. For example, in the case of a square-law detector, a doubling of the noise-power input to the detector is indicated by a doubling of detector current.

Alternative Method

26. When the characteristic of the second detector is such that measurement of the doubling of power output cannot be carried out as described in Paragraphs 22-25, the noise factor is measured using the method outlined below.

- (1) Connect the Noise Generator to the receiver under test.
- (2) With no diode anode current, adjust the noise-power output from the receiver to a convenient value  $M_1$ .
- (3) Increase the diode anode current until the noise-power output from the receiver rises to  $M_2$ .
- (4) Measure the diode anode current ( $I_1$  amps).
- (5) Increase the diode anode current until the receiver noise-power output is  $M_3$ .
- (6) Reduce the receiver gain until the receiver noise-power output falls to its original value  $M_1$ .
- (7) Measure the diode anode current ( $I_2$  amps).
- (8) Increase the diode anode current until the receiver noise-power output again rises to  $M_2$ .
- (9) Measure the diode anode current ( $I_3$  amps).
- (10) Calculate the noise factor from the formula  $10 \log_{10} \frac{20 I_1 I_2 R}{I_3 - I_2 - I_1}$ ,

Where R ohms is the value of the Noise Generator output impedance. The formula quoted gives the noise factor in decibels.

Chapter 2

27. In paragraph 26, it is assumed that the receiver gain is linear. Since the noise-factor formula contains three different values of diode anode current, it is not possible to provide noise-factor scales for this method of measurement.

Note

28. The formulae for noise factor given in the preceding paragraphs have been based on the assumption that no resistive circuit is interposed between the Noise Generator and the receiver. This is not so, in the case of receivers requiring a source impedance of 400 ohms, owing to the use of an external resistive adaptor; hence these formulae are directly applicable only when the Noise Generator output impedance is 43 ohms or 75 ohms.

29. However, it is possible to use these formulae when the Noise Generator output impedance is 400 ohms, by substituting in the formulae a value of 15 ohms for  $R$ , instead of taking  $R$  as the output impedance.

# **PART 2**

## **CHAPTER 1**



### **OPERATING INSTRUCTIONS**

## **CHAPTER 2**



### **MAINTENANCE**

**APENDIX A** — The effect of noise on radio communication

**APENDIX B** — The theory of noise factor measurement

**APENDIX C** — Noise gain and its use as a measurement of  
Communication Receiver measurement

CHAPTER 1

OPERATING INSTRUCTIONS

LIST OF CONTENTS

	<u>Paragraph</u>
General	1-3
Preliminary	4
COMMUNICATION RECEIVERS	5
RADAR RECEIVERS	
Introduction	6-10
Method 1	11
Method 2	12
Method 3	13



CHAPTER 1

OPERATING INSTRUCTIONS

General

1. The Noise Generator is designed for noise factor measurement of communication receivers, metric radar receivers and wide-band i. f. amplifiers in the frequency range 15 kc/s to 100 Mc/s; it is calibrated directly in noise factor. The built-in OUTPUT METER is used when testing communication receivers only; when testing radar receivers and i. f. amplifiers, the second-detector current meter is used as an output meter.
2. The operating instructions given herein are applicable only to receivers having linear gain; for other receivers, e. g. certain radar types, reference should be made to the relevant equipment handbook.
3. Connectors for standard equipments are contained in A. P. 60875A Box of Flexible Connections. A table showing which connectors and adaptors are suitable for use with various receivers is given below.

RECEIVER	EQUIPMENT TYPE	NOMINAL INPUT IMPEDANCE	CONNECTOR	ADAPTOR				
B28	-	75 ohms	A. P. 60861	A. P. 60865				
B40, B41	All types	75 ohms	A. P. 64960	Not required				
B46, B47	-	75 ohms	A. P. 60861	A. P. 60864				
CAS	618	75 ohms	A. P. 64960	Not required				
CAT	619							
P107	281BQ	43 ohms	A. P. 60860	Not required				
P51	293/M, 277	400 ohms	A. P. 60861	A. P. 60872				
P54	274, 275	400 ohms	A. P. 60861	A. P. 60872				
Frequency Changer Design 6	<table style="border: none;"> <tr> <td rowspan="3" style="font-size: 3em; vertical-align: middle;">}</td> <td>277P/Q</td> </tr> <tr> <td>293P/Q</td> </tr> <tr> <td>982, 983</td> </tr> </table>	}	277P/Q	293P/Q	982, 983	400 ohms	A. P. 60861	A. P. 60871
}	277P/Q							
	293P/Q							
	982, 983							

Preliminary

- 4.(1) Check that MAINS INPUT switch is in the off position. Set the voltage selector to the position appropriate to the mains supply. Connect MAINS INPUT plug to mains supply via the mains lead (A.P.67384 Flexible Connection).
- (2) Set DIODE CURRENT switch to OFF and turn DIODE CURRENT control fully counter-clockwise.

COMMUNICATION RECEIVERS

- 5.(1) Carry out the procedure given in Para. 4.
- (2) Connect Noise Generator NOISE OUT plug to the appropriate input socket on the receiver using a suitable connector (and adaptor, if required). Set the NOISE OUT switch to the position corresponding to the input impedance of the receiver.
- (3) Tune the receiver to one of its tracking frequencies. Switch noise limiter and a.g.c. off. Set r.f. gain and anti-cross-modulation controls to maximum. Switch b.f.o. on.
- (4) Connect Noise Generator AUDIO IN jack to the receiver phones output using the audio input lead (A.P.5438 Plugs with Lead). Set AUDIO IN switch to the appropriate position and adjust the receiver a.f. gain control until a convenient reading (e.g. 10 dB) is obtained on the OUTPUT METER.
- (5) Set Noise Generator MAINS INPUT switch to ON, and the DIODE CURRENT switch to 100 mA. Turn DIODE CURRENT control clockwise until the OUTPUT METER reading is 3 dB above the previous reading.
- (6) Read the noise factor from the relevant scale of the NOISE FACTOR meter (adding 10 dB, since the DIODE CURRENT switch is set to 100 mA); if the deflection of the NOISE FACTOR meter is too small to enable a reading to be obtained, set DIODE CURRENT switch to 10 mA, and read the noise factor direct from the relevant scale.

RADAR RECEIVERS

Introduction

6. There are three principal methods of measuring the noise factor of a radar receiver. The applications of these methods are given below.

(a) Method 1

This may be used when the receiver second-detector law is known and is simple (e.g. linear or square). It is necessary to know or to be able to calculate the second-detector current ratio corresponding to a doubling of the power input to the second-detector. (The current ratios for linear and square-law detection are given in Para. 11.)

(b) Method 2

If it is found difficult to determine the required second-detector current ratio, or if the second-detector law is not known, this method may be employed.

(c) Method 3

This method is considered to be the most accurate one, but it can be used only when an r.f. attenuator of 80 ohms impedance is available. Thus its use is restricted to Dockyard Radio Sections, etc. When using this method, no account need be taken of the second-detector law.

7. In order to determine whether the second-detector is linear or non-linear, measure the noise factor of the receiver by Method 2; also measure the noise factor by Method 1, by assuming that the second-detector is linear. If the two values of noise factor obtained are the same, the second-detector is, in fact, linear.
8. It is assumed in Paras. 11-13 that the receiver under test has an input impedance of 400 ohms, and that the various values of second-detector current quoted therein (in the range 100-250 microamps) are of suitable magnitude. Reference should be made to the relevant equipment handbook in order to confirm that these assumptions are correct; if they are incorrect, then the instructions given in Paras. 11-13 should be modified accordingly.
9. Check that the lowest value of second-detector current to be used in the test is not less than five times the standing current. (With no signal applied to the i.f. amplifier and with the gain control at minimum, the second-detector meter indicates the standing current.)
10. Check that the i.f. amplifier does not limit at (or below) the highest value of second-detector current it is proposed to use during the test.

Method 1

- 11.(1) Carry out the procedure given in Para. 4.
  - (2) Connect the equipment as shown in Fig. 8A, removing the mixer crystal and replacing it by the appropriate adaptor and connector.
  - (3) Set the Noise Generator MAINS INPUT switch to ON, and switch on the rest of the equipment.
  - (4) Set NOISE OUT switch to 400 ohms, and adjust receiver gain control to give a deflection of 100 microamps on the second-detector meter.
  - (5) Set DIODE CURRENT switch to 100 mA.
  - (6) Turn DIODE CURRENT control in a clockwise direction until the second-detector meter indicates 141 microamps (if the detector is linear) or 200 microamps (if the detector is square-law).
  - (7) Read the noise factor from the relevant scale of the NOISE FACTOR meter, i.e. the scale relating to an impedance of 400 ohms. Add 10 dB to the reading if it is within the right-hand portion (i.e. 1-2-3-4) of the scale; read direct if it is within the left-hand portion (i.e. 4-6-8-10).

- (8) If the noise factor is less than 4 dB, set DIODE CURRENT switch to 10 mA, and read the noise factor direct from the right-hand portion of the scale.

Method 2

- 12.(1) Carry out the procedure given in Para. 4.
- (2) Connect the equipment as shown in Fig. 8A, removing the mixer crystal and replacing it by the appropriate adaptor and connector.
- (3) Set the Noise Generator MAINS INPUT switch to ON, and switch on the rest of the equipment.
- (4) Set NOISE OUT switch to 400 ohms, and adjust receiver gain control to give a deflection of 100 microamps on the second-detector meter.
- (5) Set DIODE CURRENT switch to 100 mA.
- (6) Turn DIODE CURRENT control clockwise until the second-detector meter indicates 200 microamps.
- (7) Read the diode anode current ( $I_1$  amps) on the NOISE FACTOR meter; since the DIODE CURRENT switch is set to 100 mA, the meter reading must be multiplied by 10.
- (8) Turn DIODE CURRENT control clockwise until the second-detector meter indicates 250 microamps.
- (9) Adjust the receiver gain control until the second-detector meter again indicates 100 microamps.
- (10) Read the diode anode current ( $I_2$  amps) on the NOISE FACTOR meter (multiplying the reading by 10).
- (11) Turn DIODE CURRENT control clockwise until the second-detector meter again indicates 200 microamps.
- (12) Read the diode anode current ( $I_3$  amps) on the NOISE FACTOR meter (multiplying the reading by 10).
- (13) Calculate the noise factor from the formula  $10 \log_{10} \frac{20I_1I_2R}{I_3-I_2-I_1}$

see Part 1, Chapter 2, Paras. 28-29.

Method 3

- 13.(1) Carry out the procedure given in Para. 4.
- (2) Connect the equipment as shown in Fig. 8B, removing the mixer crystal and replacing it by the appropriate adaptor and connector.
- (3) Set the Noise Generator MAINS INPUT switch to ON, and switch on the rest of the equipment. Set r.f. attenuator to 0 dB.

- (4) Set NOISE OUT switch to 400 ohms, and adjust receiver gain control to give a deflection of 100 microamps on the second-detector meter.
- (5) Set r.f. attenuator to 3 dB; as a result, the deflection of the second-detector meter will be reduced.
- (6) Set DIODE CURRENT switch to 100 mA.
- (7) Turn DIODE CURRENT control clockwise until the second-detector meter again indicates 100 microamps.
- (8) Read the noise factor from the relevant scale of the NOISE FACTOR meter, i. e. the scale relating to an impedance of 400 ohms. Add 10 dB to the reading if it is within the right-hand portion (i. e. 1-2-3-4) of the scale; read direct if it is within the left-hand portion (i. e. 4-6-8-10).
- (9) If the noise factor is less than 4 dB, set DIODE CURRENT switch to 10 mA, and read the noise factor direct from the right-hand portion of the scale.



CHAPTER 2

MAINTENANCE

LIST OF CONTENTS

	<u>Paragraphs</u>
General	1
Test Equipment Required	2-3
Component Location	4
Component Accessibility	5
TESTS	6
Filament Voltage	7-10
H.T. Voltage	11-15
Output Meter	16-18
Noise Diodes	19-22
Terminating Resistor	23

LIST OF FIGURES

Figure 1 - Circuit Diagram	
Figure 2 - Top View	
Figure 3 - Bottom View	
Figure 4 - Rear View	
Figure 5 - Right-Hand Side View	
Figure 6 - Front Panel and Chassis Separated	
Figure 7 - A.P.60875A Box of Flexible Connections	
Figure 8 - Block Diagrams: Noise Factor Measurement	
Figure 9 - Block Diagram: Calibration Check of Output Meter	
Component List	Facing Figure 1
List of Contents of A.P.60875A Box of Flexible Connections	Facing Figure 7



CHAPTER 2

MAINTENANCE

General

1. The few tests which need to be applied to the Noise Generator may be considered in groups as given below.
  - (a) Filament voltage tests.
  - (b) H. t. voltage tests.
  - (c) Output meter tests.
  - (d) Noise diode tests.
  - (e) Terminating resistor tests.

Test Equipment Required

2. In order to carry out the above tests, the following C.N.R.T.E. is required:-
  - (a) A.P. 32144 Avometer, Model 7X
  - (b) A.P. 100321 A.F. Variable Attenuator (Marconi TF338B)
  - (c) A.P. 104290 Oscillator, Audio Frequency (Advance J1) or  
A.P. W7252 Oscillator G205 (Obsolescent)
3. An A.P. W4085 Variac is desirable in addition to the equipment listed in Para. 2, and should be used if available.

Component Location

4. In order to locate a particular component, reference should be made to the Component List for the Noise Generator. This Component List (which faces the Circuit Diagram, Fig. 1) indicates in which figures the various components are identified. Reference should also be made to Diag. 1.1.

Component Accessibility

5. Some components are not readily accessible for servicing until the front panel has been separated from the chassis as shown in Fig. 6. The method of dismantling is given below.
  - (1) Disconnect the mains lead from the mains supply and the Noise Generator.
  - (2) Remove the four screws situated one at each corner of the front panel and take the instrument out of its case.
  - (3) Remove the two front handles. (Access to the heads of the fixing screws is provided by suitably placed holes in the chassis.)

- (4) Unsolder capacitor C5 from the pin of NOISE OUT plug PLA. Unsolder also the bare earth-wire from plug PLA at the junction of resistors R10 and R11.
- (5) Separate the front panel from the chassis as shown in Fig. 6, and stand the chassis on the rear guard-rails.
- (6) After completion of servicing, re-assemble the instrument, following the above procedure in reverse.

### TESTS

6. Before commencing the tests detailed below, remove the instrument from its case as described in Para. 5(1)-(2).

#### Filament Voltage

7. If a Variac is not available, measure the voltage of the mains supply using the Avometer (400V a. c. range), and set the Noise Generator mains voltage selector to the appropriate position. Check that the MAINS INPUT switch is in the off position. Connect the MAINS INPUT plug to the mains supply via the mains lead (A.P.67384 Flexible Connection).
8. If a Variac is available, set the mains voltage selector to the 230V position. Check that the MAINS INPUT switch is in the off position. Connect the MAINS INPUT plug to the mains supply via the mains lead and Variac. Set the output of the Variac to 230V as indicated on the Avometer (400V a. c. range).
9. (1) Connect the Avometer (10V a. c. range) negative terminal to the Noise Generator chassis and the positive terminal to tag 1 on the tag strip. (The tag strip is situated on the right-hand side of the instrument, see Fig. 5, and is numbered from 1 to 20.)  
(2) Turn DIODE CURRENT control fully counter-clockwise and set DIODE CURRENT switch to OFF.  
(3) Set MAINS INPUT switch to ON; after three minutes have elapsed, check that the voltage indicated on the Avometer is  $2.1V \pm 0.3V$ .  
(4) Turn DIODE CURRENT control fully clockwise. Check that the voltage indicated on the Avometer is  $6.0V \pm 0.4V$ .  
(5) Set DIODE CURRENT switch to 100 mA position; check that, as a result of this action, the Avometer reading is reduced by not more than 0.3V.  
Caution. Immediately after completion of this measurement, turn DIODE CURRENT control fully counter-clockwise.
10. If the voltage readings obtained do not meet the requirements given in Para. 9, check that the filaments of the noise diodes (V2 and V3) are glowing; also check RV7, the voltage of the relevant secondary of TR1, and C6.

H.T. Voltage

11. It is assumed that the procedure detailed in Paras. 7 - 9 has been carried out and that the Noise Generator controls are set as at the end of Para. 9.
12. (1) Return DIODE CURRENT switch and MAINS INPUT switch to the off position.  
(2) Disconnect the positive terminal of the Avometer from Tag 1; after setting the Avometer to the 400V d.c. range, connect the positive terminal to the 275V test socket on the Noise Generator front panel.  
(3) Set MAINS INPUT switch to ON; check that the voltage indicated on the Avometer is  $260V \pm 20V$ .
13. If this voltage reading is outside tolerance, check rectifier valve V1, capacitors C2 and C3, choke L1, resistor R12, and the voltages of the relevant secondaries of TR1.
14. With the equipment set up as at the end of Para. 12, continue as described below.
  - (1) Set DIODE CURRENT switch to the 100 mA position.
  - (2) Adjust DIODE CURRENT control until the NOISE FACTOR meter indicates a current of 40 mA. (This current is indicated by a scale reading of 4 mA with the DIODE CURRENT switch in the 100mA position.)
  - (3) Check that the voltage indicated on the Avometer is  $195V \pm 15V$ .
15. If this voltage reading is outside tolerance, check meter M2 and shunts, switch S3 and the components listed in Para. 13 if not already checked.

Output Meter

16. (1) Set the Noise Generator MAINS INPUT switch to the off position.
  - (2) Connect the various instruments as shown in Fig. 9.
  - (3) Set the Variable Attenuator ATTENUATION dial to 25 dB, the ATTENUATION switch to 0 dB, and the TERMINATION switch to EXT.
  - (4) Adjust the Oscillator output to approximately 15V at 1000 c/s. (In the case of Oscillator A.P.104290, the 600 ohms terminals are to be used, the 600 ohms ATTENUATOR set to zero, and the OUTPUT control set to 15 VOLTS. In the case of Oscillator A.P.W7252, the output voltage is to be set to 15V as measured on the voltmeter provided, with the METER SWITCH in the A.C. VOLTS position).
  - (5) Set Noise Generator AUDIO IN switch to MEDIUM.
  - (6) Turn Variable Attenuator ATTENUATION dial counter-clockwise until the Noise Generator OUTPUT METER reading is 12 dB.

- (7) Note the reading on the ATTENUATION dial of the Variable Attenuator; this will normally be approx. 20 dB.
  - (8) Turn Variable Attenuator ATTENUATION dial counter-clockwise until the Noise Generator OUTPUT METER reading is 15 dB. The ATTENUATION dial reading should now be 3 dB down on the previous reading as noted in (7).
  - (9) Check the calibration of the OUTPUT METER over its complete range by repeating the procedure in (8) for each OUTPUT METER graduation. The change in ATTENUATION dial reading in each case should be equal in magnitude to the change in OUTPUT METER reading, but of opposite sign.
17. If the calibration of the OUTPUT METER is incorrect, or if the OUTPUT METER does not function, use the Avometer to check the resistance at the AUDIO IN jack.
- (1) Set AUDIO IN switch to LOW; measure the resistance across the AUDIO IN jack, with the Noise Generator disconnected from the Variable Attenuator. This resistance should be 12 ohms  $\pm$  4 ohms.
  - (2) Set AUDIO IN switch to MEDIUM; the resistance should be 47 ohms  $\pm$  7 ohms.
  - (3) Set AUDIO IN switch to HIGH; the resistance should be 95 ohms  $\pm$  10 ohms.
18. If the readings obtained as in Para. 17 are within tolerance, check that the resistance of resistor R5 is 5000 ohms  $\pm$  5%. The OUTPUT METER has a full scale deflection of 200 microamps; should a fault occur in it, or in rectifier MR1 or resistor R6, it is advisable to replace the complete meter assembly (A.P. 60873).

#### Noise Diodes

19. (1) Set the Noise Generator MAINS INPUT switch to ON.
- (2) With the DIODE CURRENT switch in the 100 mA position, turn the DIODE CURRENT control slowly clockwise until the NOISE FACTOR meter indicates a current of 90 mA. (This current is indicated by a scale reading of 9 mA with the DIODE CURRENT switch in the 100 mA position.)
- Caution. Immediately after completion of this operation turn DIODE CURRENT control fully counter-clockwise.
20. If the current reading is less than 90 mA when the DIODE CURRENT control is fully clockwise, check the noise diodes (V2 and V3).
- (1) Set the Noise Generator MAINS INPUT switch to the off position.
  - (2) Unsolder one group of diode anode leads at the stand-off insulator.
  - (3) Proceed as in Para. 19, and check that a current of 45 mA can be obtained with the one noise diode in circuit.
  - (4) Set the Noise Generator MAINS INPUT switch to the off position.

- (5) Resolder the one group of diode anode leads to the stand-off insulator, and unsolder the other group.
  - (6) Check the second noise diode in a similar manner.
  - (7) Replace diode(s), if faulty.
21. If no current is indicated on the NOISE FACTOR meter, check resistor R8, meter M2 and shunts, switch S3. If the values of current are satisfactory, a communication receiver (e.g. a B40 or B28) may be used to confirm that noise power is available from the Noise Generator; if it is not, check capacitor C5 and the output circuit.
22. Valve lead connections The anodes of V2 and V3 are each connected to four valve leads (1, 3, 6 and 8) grouped together and soldered to a stand-off insulator. Filament lead 4 (brown) of both V2 and V3 is connected to C6; filament lead 5 (brown) of both V2 and V3 is connected to a solder tag on the chassis.

#### Terminating Resistor

- 23.(1) Set the Noise Generator MAINS INPUT switch to the off position, and the NOISE OUT switch to the 43 ohms position.
- (2) Measure the resistance between the chassis and the pin of the NOISE OUT plug; this resistance should be 50 ohms  $\pm$  1 ohm.
- (3) With the NOISE OUT switch in the 75 ohms or 400 ohms position, the resistance should be 82 ohms  $\pm$  1 ohm.

Note:- Allowance must be made for the possible error of the Avometer on resistance ranges.

COMPONENT LIST

A . P . 6 7 1 6 6 NOISE GENERATOR CT 8 2

NOTE: Before ordering replaceable parts reference should be made to the relevant E List and the Substitution Guide.

Circuit Ref.	Description	J.S. or A.P. No.	Value	Tol. %	Rating	Shown in Fig.
R1	Resistor, composition, grade 2	Z221008	12 ohms	± 10	½W	6
R2	" " "	Z221067	47 "	"	"	"
R3	" " "	Z221002	10 "	"	"	2,6
R4	" " "	"	10 "	"	"	"
R5	" wire-wound	Z244069	5k ohms	± 5	¼W	"
R6	Supplied with meter M1	-	-	-	-	-
R8	Resistor, wire-wound	Z113397	1k ohm	± 5	6W	3,6
R10	" composition, grade 1	A.P.61007	82 ohms	± 1	½W	"
R11	" " "	A.P.61006	50 ohms	"	"	"
R12	" wire-wound	Z244141	33k ohms	± 5	6W	2,6
RV7	Resistor, variable, wire-wound	A.P.67168	3 ohms	± 7½	25W	3,5,6
C1	Capacitor, mica	Z124409	0.01 µF	± 20	750V	2,6
C2	" paper	Z112883	4 µF	"	250V	3,4,5,6
C3	" " "	"	"	"	"	2,4,6
C4	" mica	Z124409	0.01 µF	"	750V	3,6
C5	Capacitor, mica	Z124425	0.02 µF	± 5	350V	3,6
C6	" "	Z124180	0.002 µF	± 20	750V	"
MR1	Supplied with meter M1	-	-	-	-	-
TR1	Transformer, single phase	A.P.67171	-	-	-	2,3,4,5,6
TR2	" audio	A.P.67172	-	-	-	3,4,5,6
L1	Choke, 8H	A.P.67173	-	-	-	2,4
LP1	Signal lamp, red (i.e. lampholder)	A.P.W6547A	-	-	-	6
LP1	Lamp, 6.2V 1.8W, M.E.S.	X951211	-	-	-	-
M1	Meter, 0-200 µA	A.P.60873	-	-	-	2,5,6
M2	" 0-10 mA	A.P.60874	-	-	-	"
M2	Shunt; supplied with meter M2	-	-	-	-	3,6
S1	Switch, toggle, d.p., on-off	Z510305	-	-	-	6
S2	" 1 pole, 3 way	A.P.67167	-	-	-	3,6
S3	" toggle, d.p., 3 way	A.P.60877	-	-	-	"
S4	" 1 pole, 3 way	A.P.67167	-	-	-	"
PLA	Plug, r.f., coaxial	Z560045	-	-	-	3,6
PL1	" fixed, female, 3 pole	Z560565	-	-	-	"
-	Clamp, capacitor	Z970018	-	-	-	-
FS1	Fuseholder	Z590100	-	-	-	2,6
FS1	Fuse-link, H.R.C., midget, 1A	Z590109	-	-	-	-
FS2	Fuseholder	Z590100	-	-	-	2,6
FS2	Fuse-link, H.R.C., midget, 1A	Z590109	-	-	-	-
FS3	Fuseholder	Z590100	-	-	-	2,6
FS3	Fuse-link, H.R.C., midget, ½A	Z590107	-	-	-	-
-	Strap, webbing	A.P.5890	-	-	-	-
V1	Valve, electronic	CV493	-	-	-	2,4,6
V2	" "	CV2398	-	-	-	3,6
V3	" "	"	-	-	-	"
-	Valveholder, B7G, grade 2, H2	Z560132	-	-	-	-
-	Valve retainer, style VR1-D	Z970291	-	-	-	-
JKA	Jack, type 17	10H/1049	-	-	-	3,6
SK1	Socket	10H/2678	-	-	-	-
SK2	"	"	-	-	-	-
-	Knob, body	Z970173	-	-	-	-
-	Mounting, metal, for knob	Z970183	-	-	-	-
-	Cap, retaining, for knob	Z970184	-	-	-	-

R		8		10	11		12		1	2	
C			b 5 4						3	2	
MISC.	V2	V3		S3	M2	S4	JKA	RV7	SK2	S2	L1

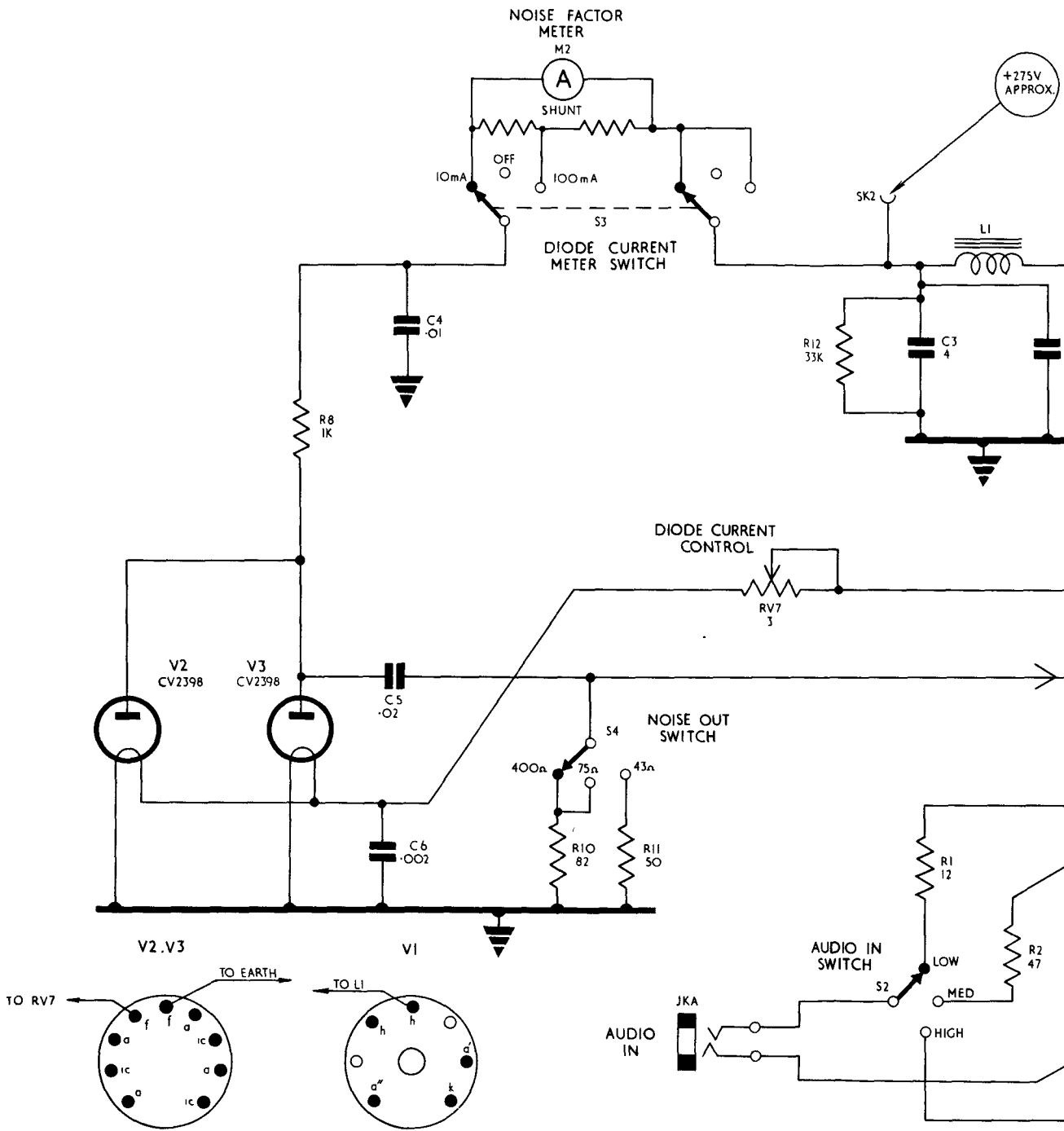

V2.V3

V1

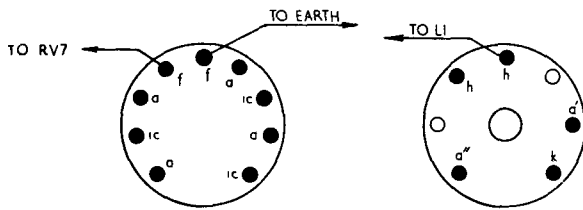

VALVE BASE CONNECTIONS

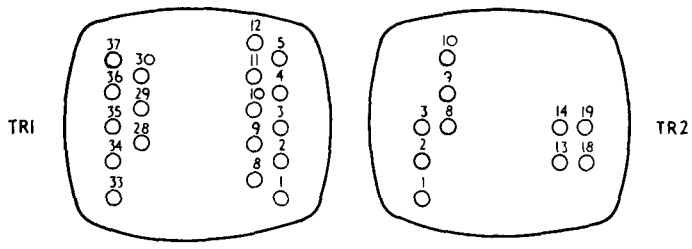
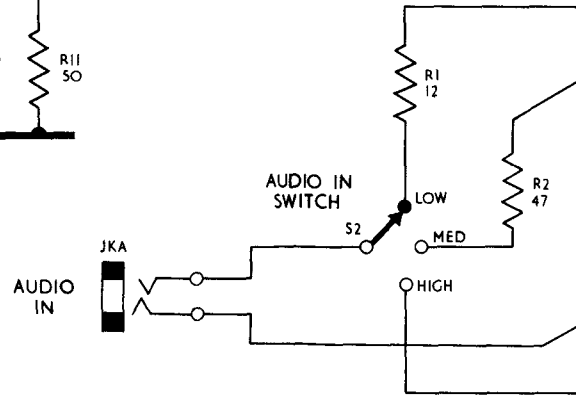

TRANSFORMER CONNECTIONS







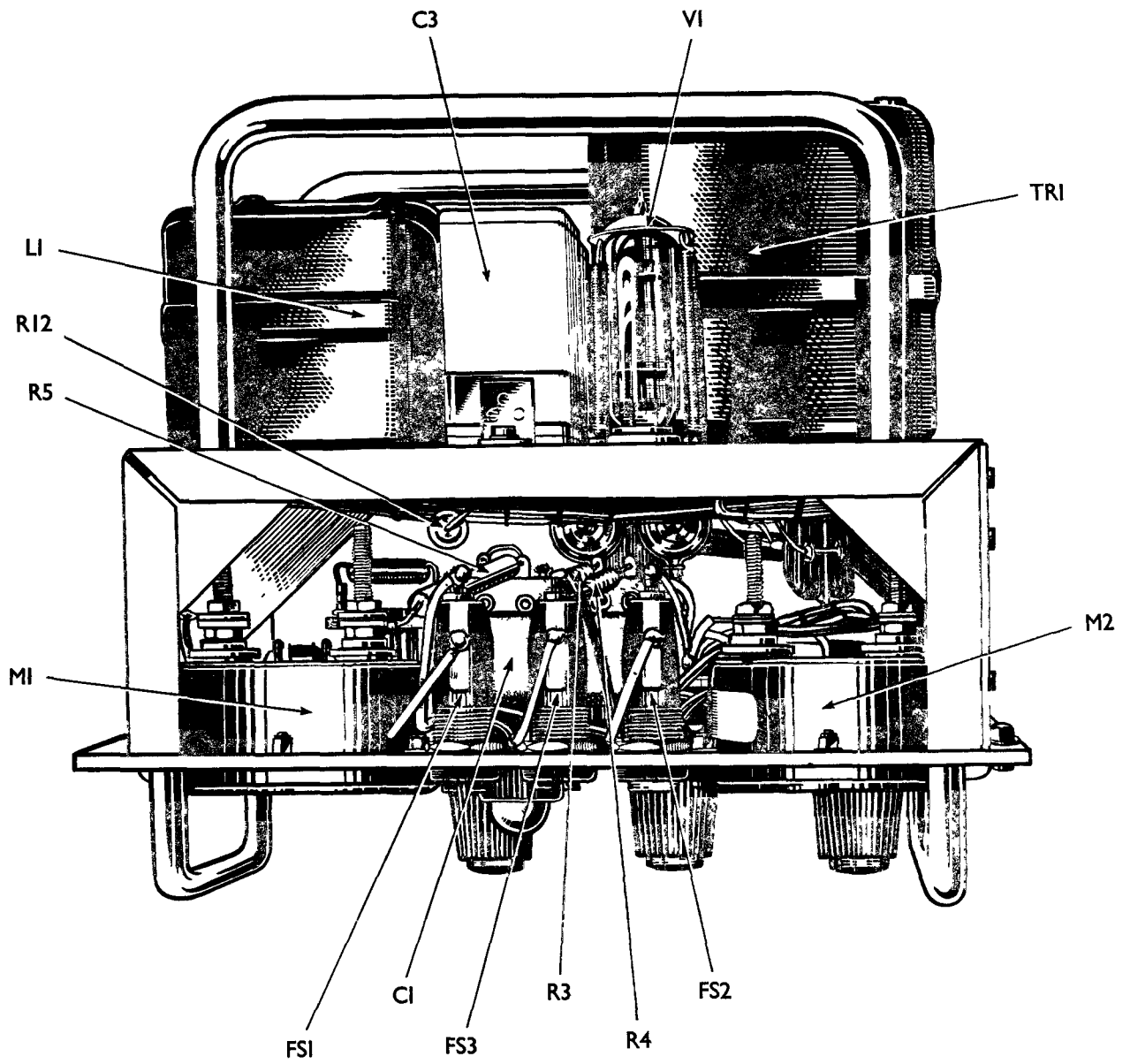

A.P. 67166 NOISE GENERATOR CT 82  
TOP VIEW



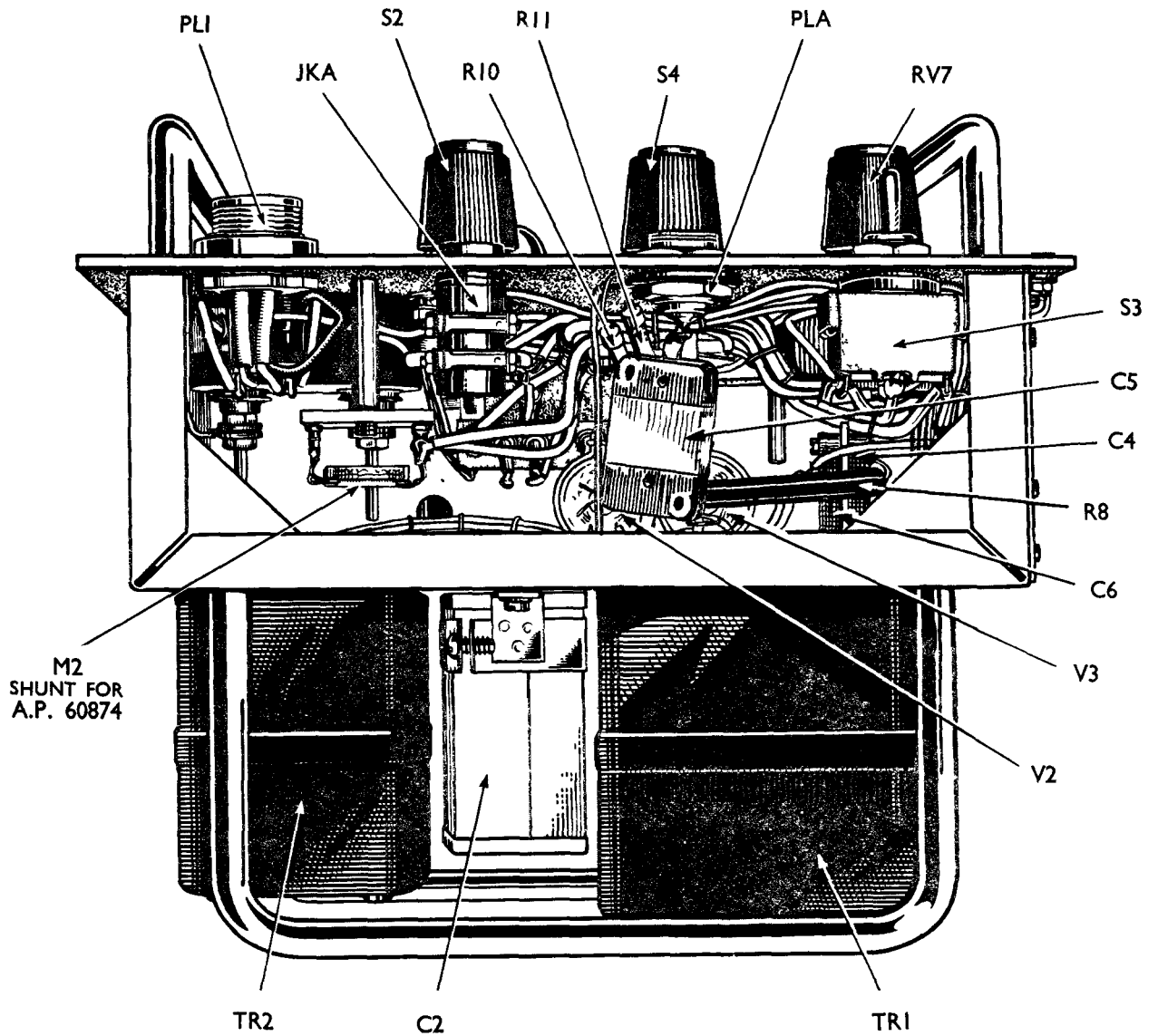

A.P. 67166 NOISE GENERATOR CT 82  
BOTTOM VIEW



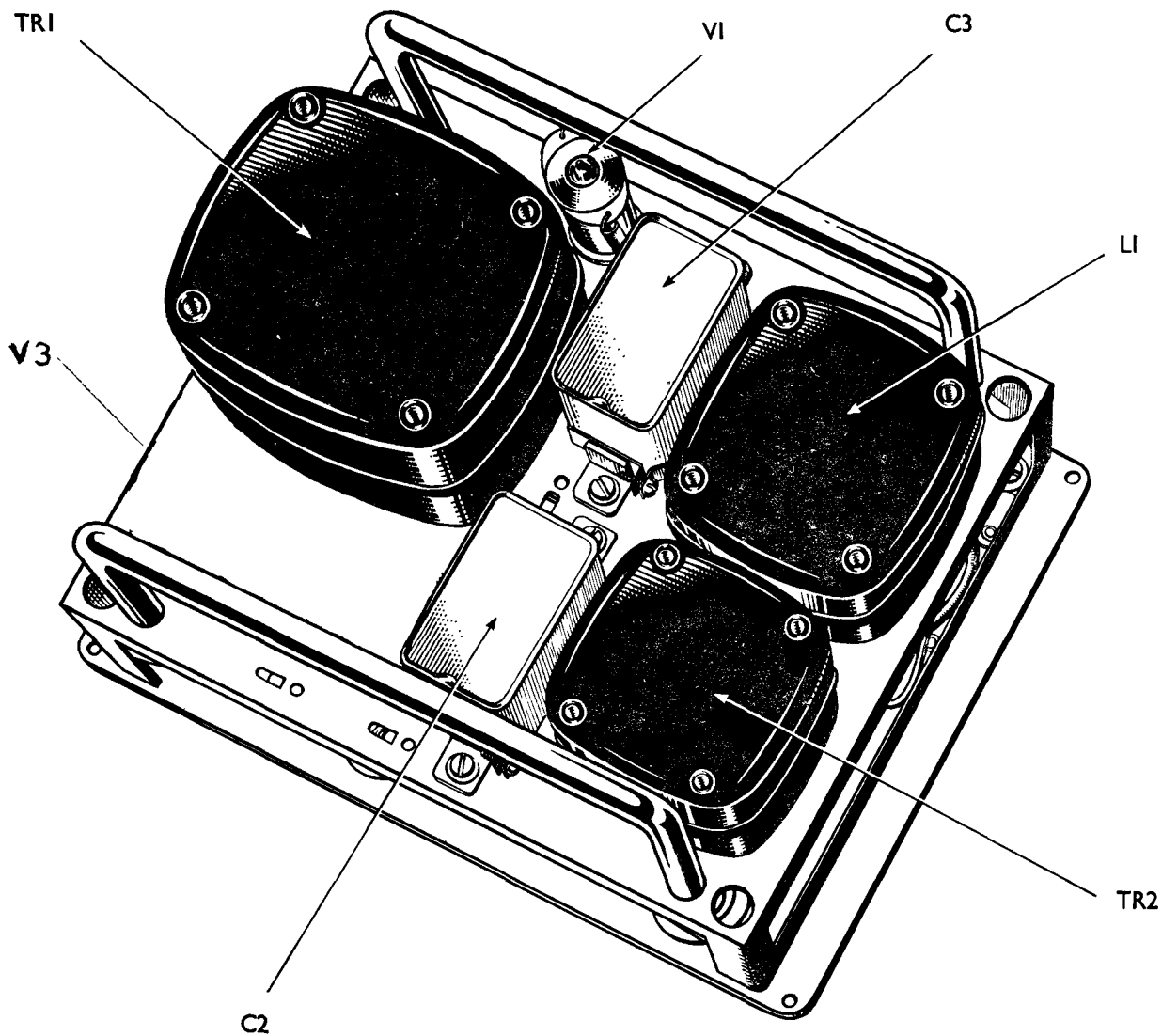

A.P. 67166 NOISE GENERATOR CT 82  
REAR VIEW



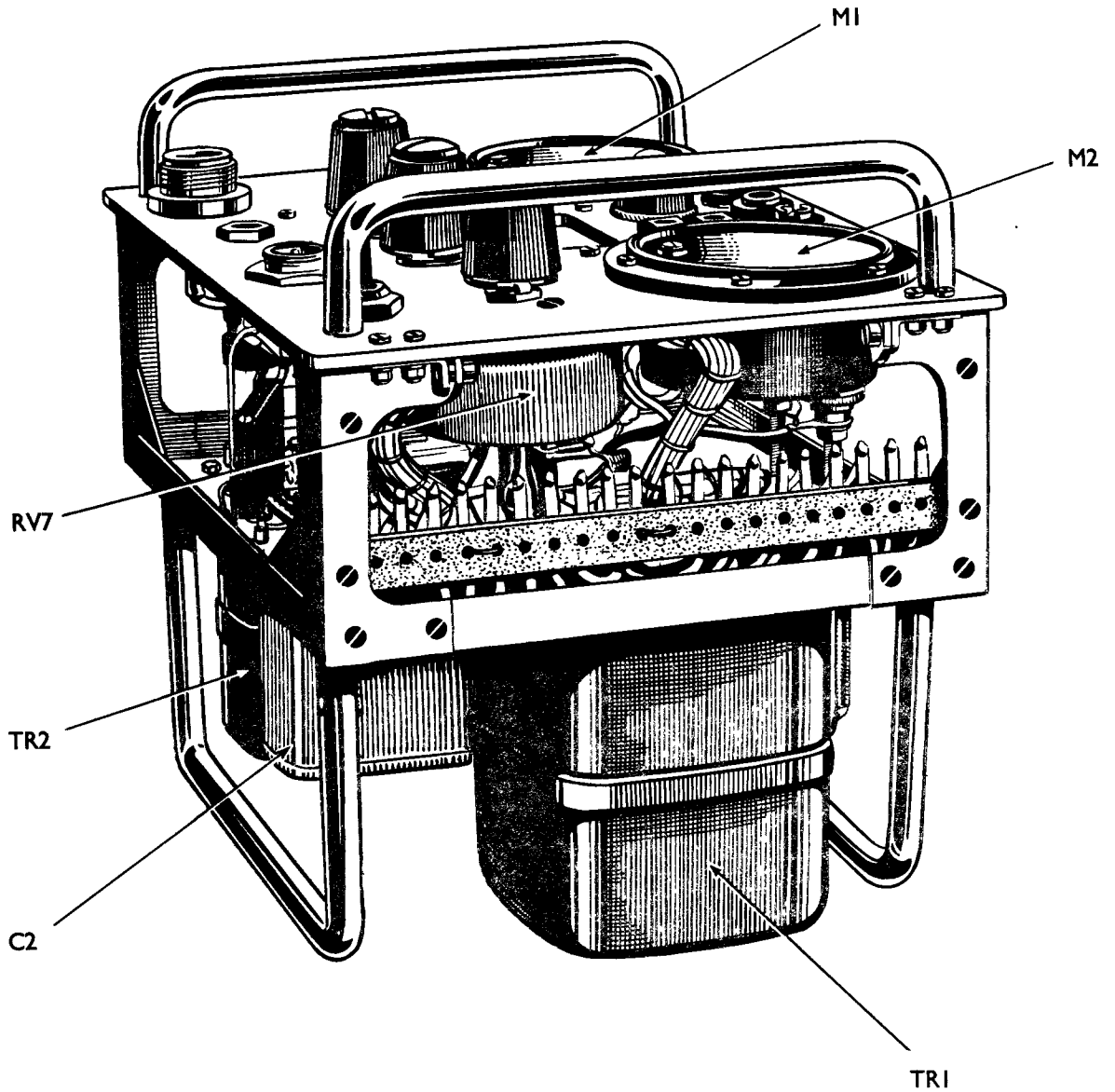

A.P. 67166 NOISE GENERATOR CT 82  
RIGHT-HAND SIDE VIEW



This sheet issued with A.L. No. 1 January 1958

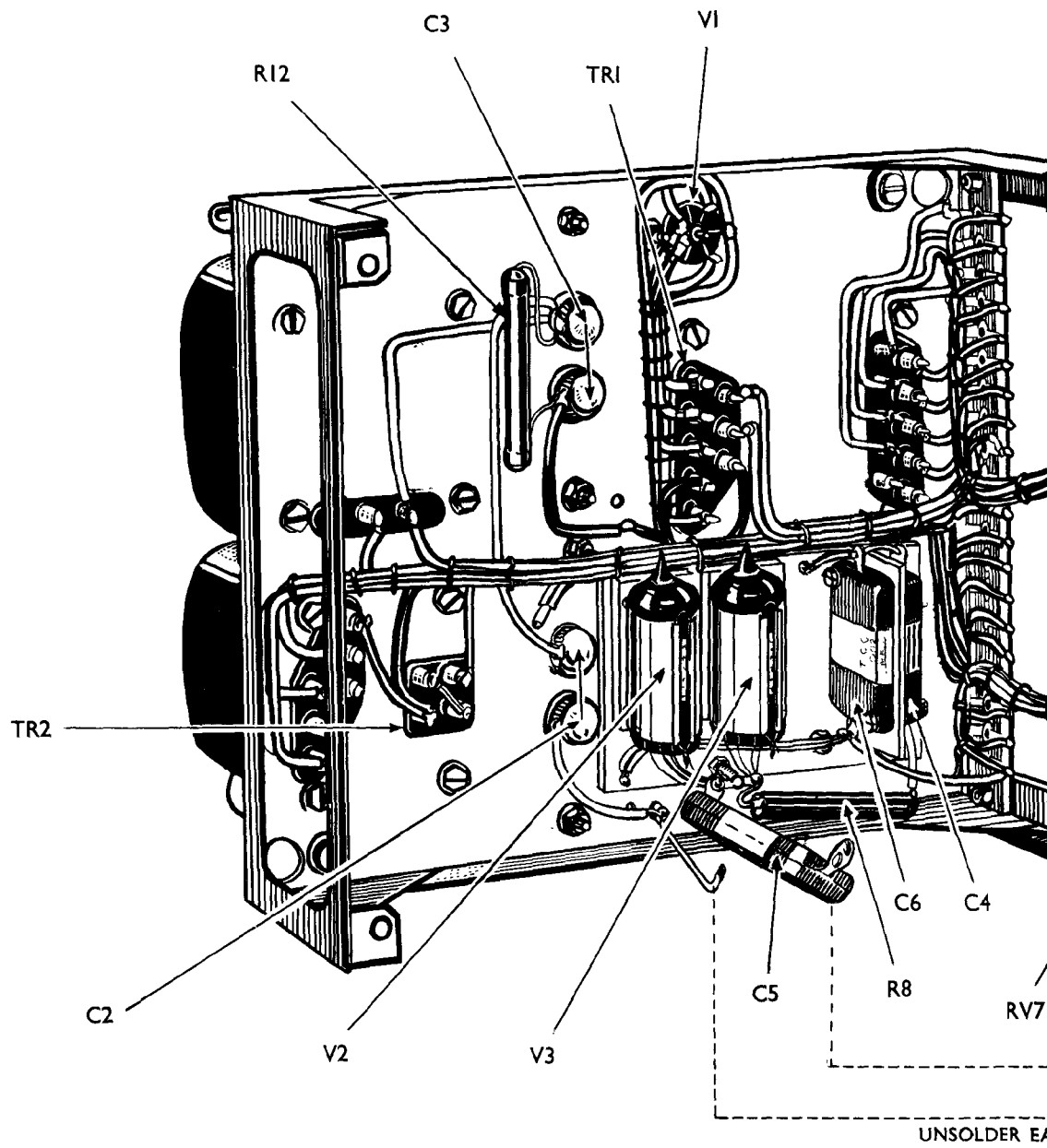

A.P. 67166  
FRONT PA



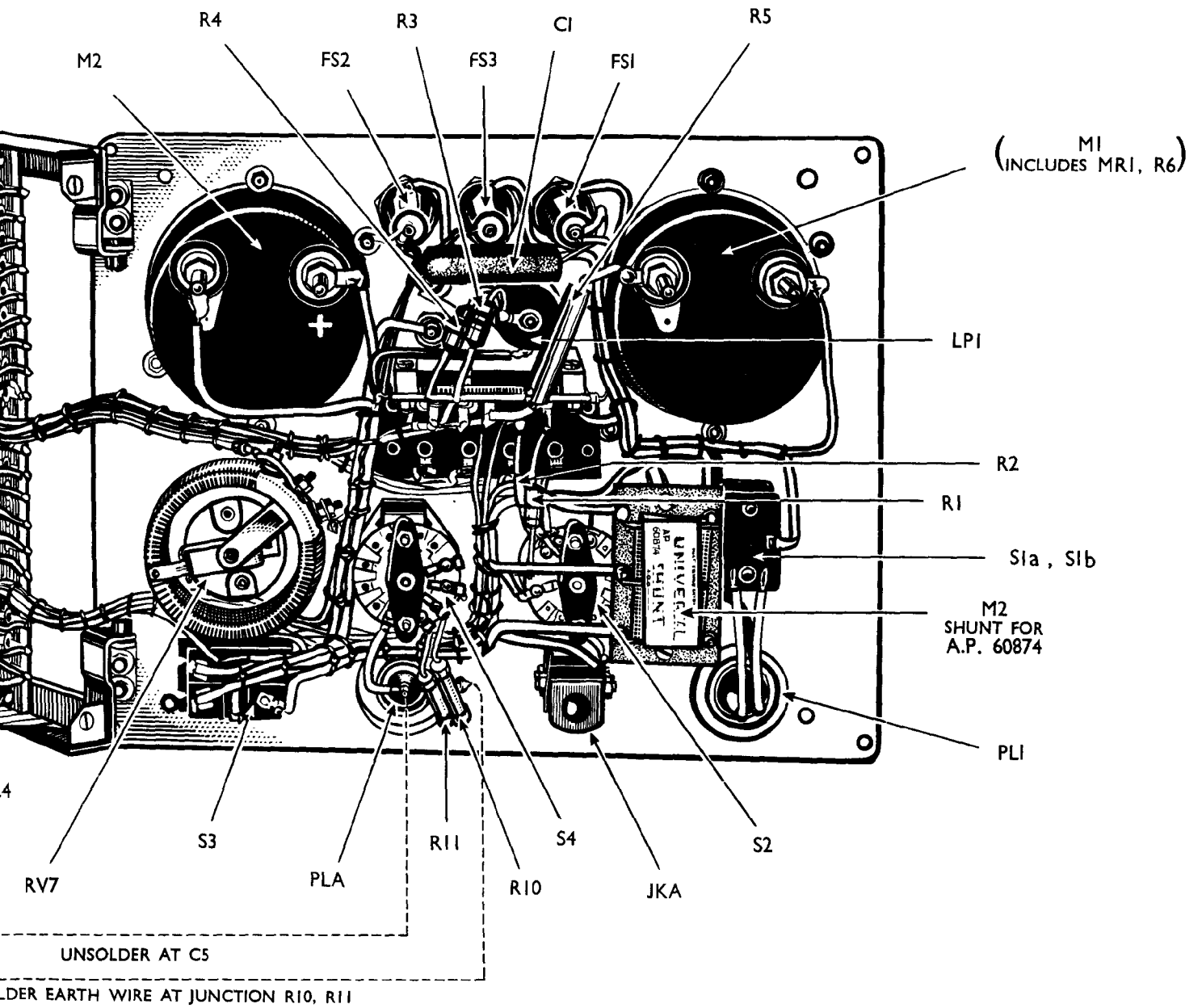

66 NOISE GENERATOR CT 82  
FRONT PANEL AND CHASSIS SEPARATED

FIG. 6



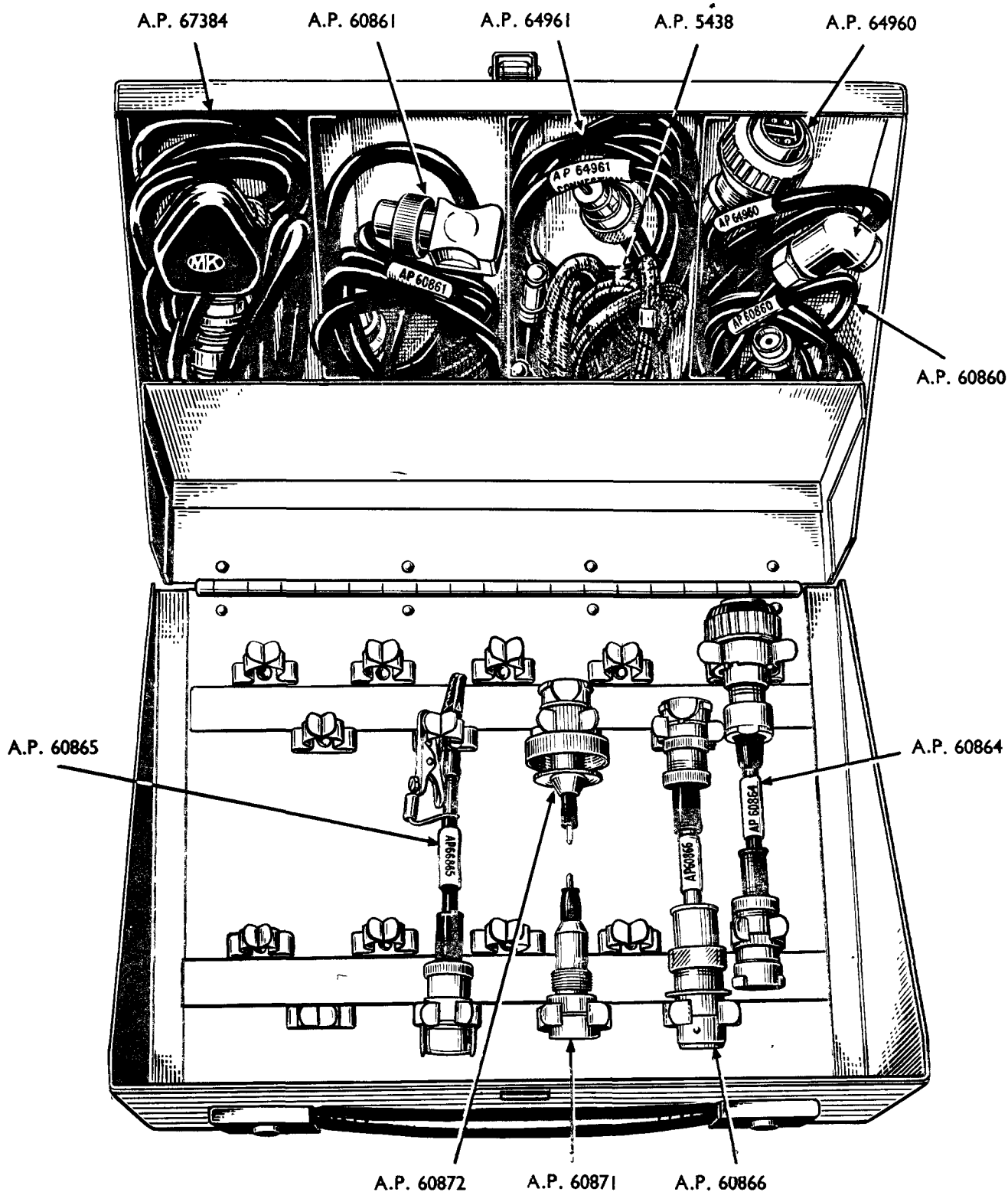

A.P. 60875A BOX OF FLEXIBLE CONNECTIONS



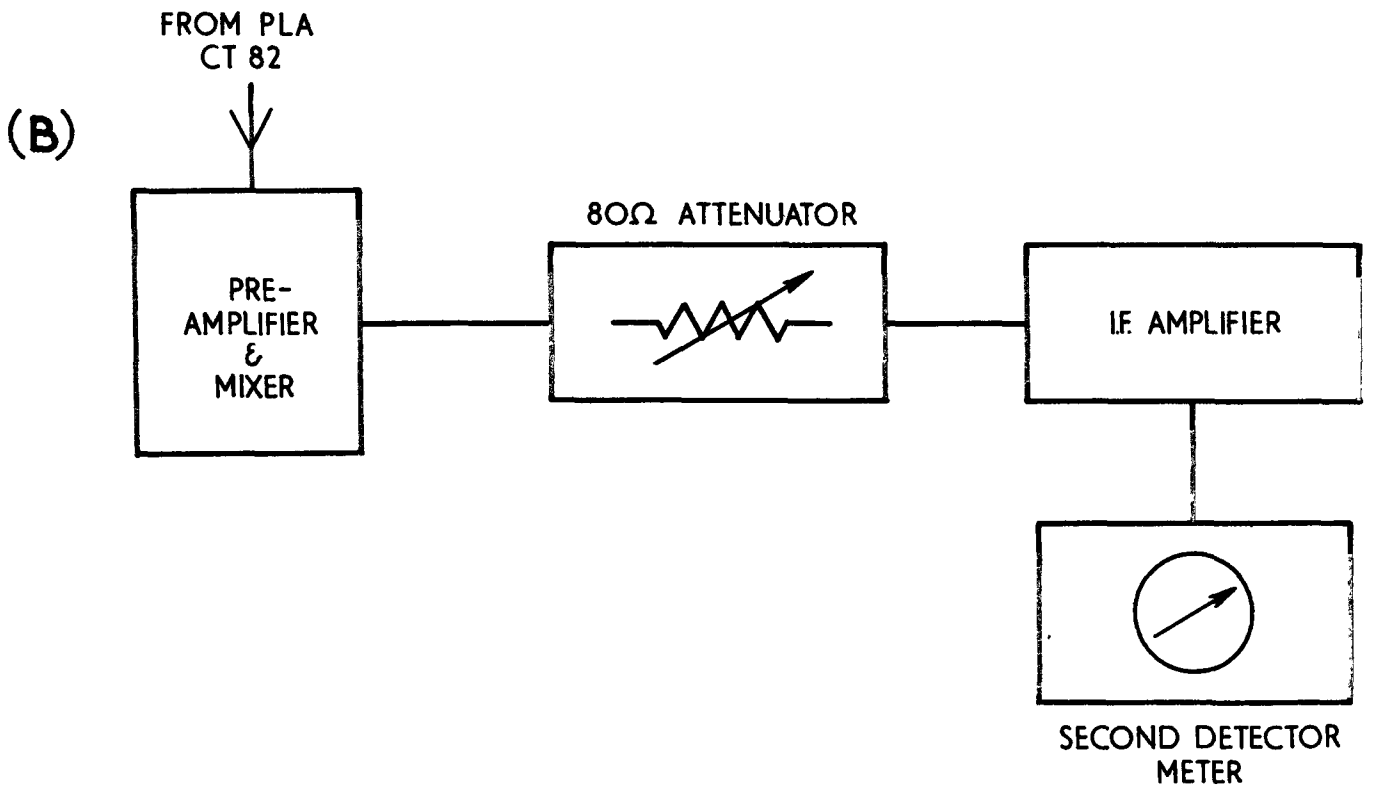
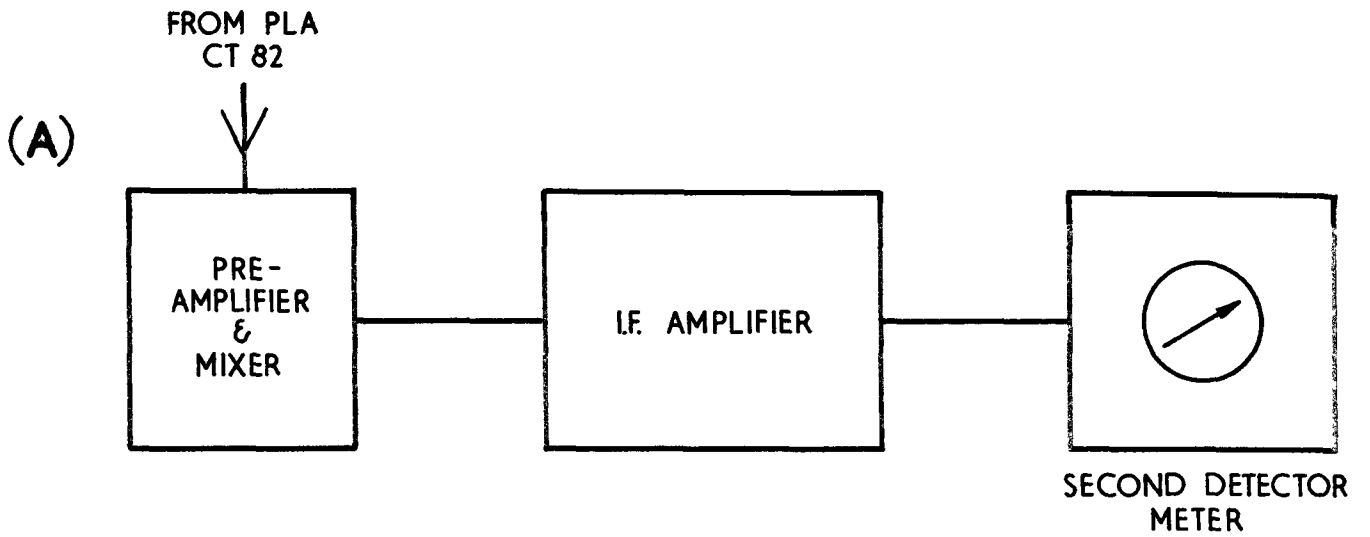

BLOCK DIAGRAMS: NOISE FACTOR MEASUREMENT



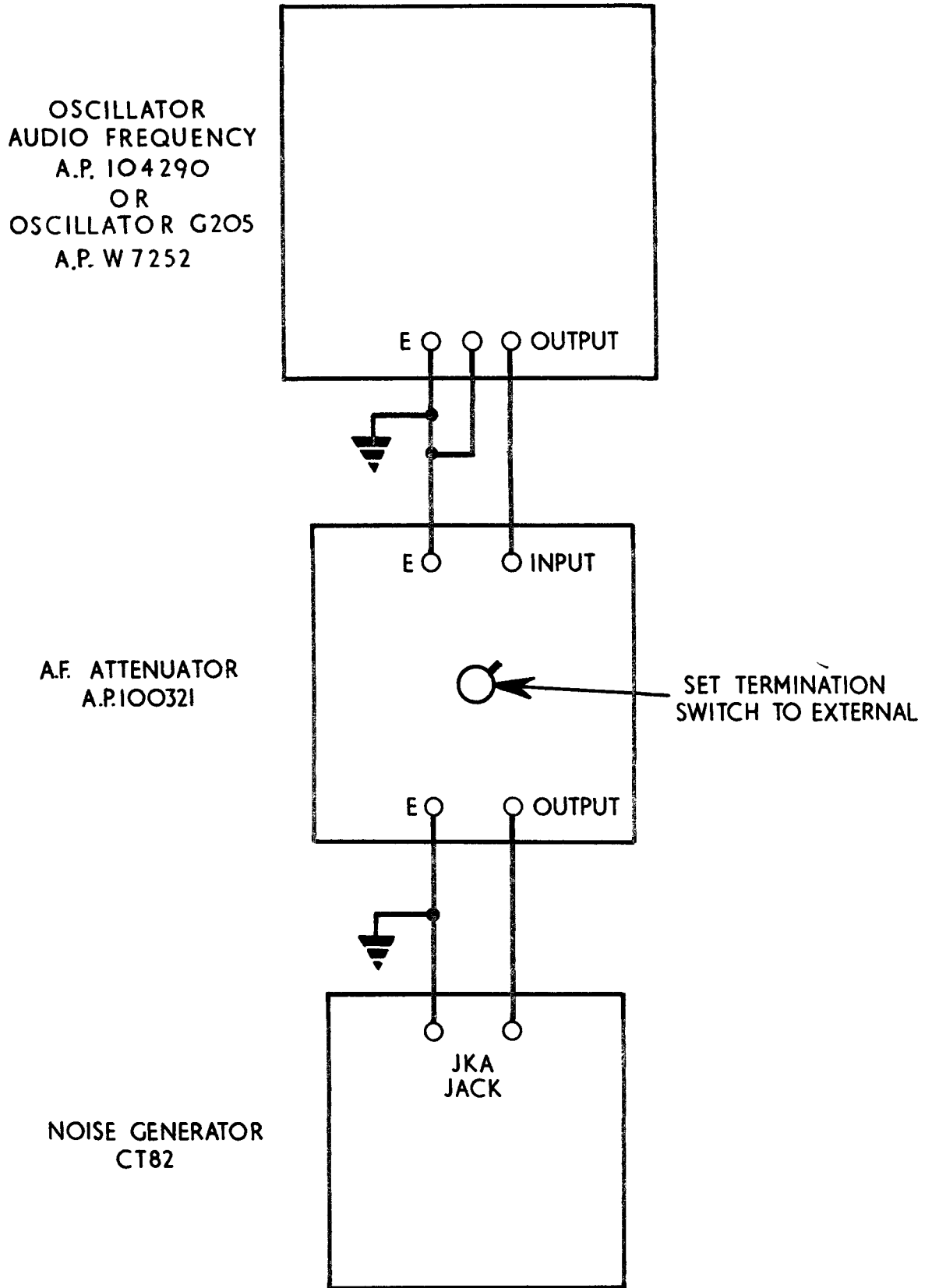

BLOCK DIAGRAM: CALIBRATION CHECK OF  
OUTPUT METER



A P P E N D I X ' A '

T H E E F F E C T O F N O I S E O N

R A D I O C O M M U N I C A T I O N

L I S T O F C O N T E N T S

	<u>Paragraph</u>
Introduction	1-2
Externally-Generated Noise	3-9
Internally-Generated Noise	10-12
Conclusions	13-16



APPENDIX 'A'

THE EFFECT OF NOISE ON

RADIO COMMUNICATION

Introduction

1. The ultimate requirement for any radio communication system is that it should provide a usable signal output from the receiver. This output may be in many different forms depending on the type of modulation being used. There is always, however, a certain amount of noise mixed with the useful signal. This noise may usually be distinguished as the hissing or rushing sound heard in the absence of a signal. There is thus a certain signal-to-noise ratio at the receiver output terminals. The signal-to-noise ratio necessary for satisfactory reception of the intelligence contained in the signal depends on the form of the modulation. For good voice communication a signal-to-noise ratio of some 15 dB is required. For hand-speed morse a ratio of approximately unity may be used, and so on.
2. Some of the noise present in the receiver output enters the receiver from the aerial, being generated in the aerial or picked up together with the signal. Some of the noise is generated within the receiver itself. Using modern valves it is comparatively easy to design a receiver having sufficient gain to amplify these noise voltages (which are at a level of approximately one microvolt) to the level necessary for efficient operation of the second detector. There is no point in increasing the gain above this value as signals that are substantially less than the noise cannot be made use of. An understanding of noise problems, as well as knowledge of the signal propagation characteristics, is therefore necessary in any appraisal of a particular communication system.

EXTERNALLY-GENERATED NOISE

3. Noise picked up by the aerial together with the signal may be divided into three classes:-
  - (a) Man-made noise.
  - (b) Atmospheric noise.
  - (c) Cosmic noise.

Man-made noise

4. The amount of man-made noise picked up will depend greatly on the location of the aerial. It is generated by the multitude of devices which, deliberately or accidentally, cause sparking. The interference due to unsuppressed commutator motors is too well known to need comment. Dirty contacts in lighting circuits are another cause. Less obvious is the noise caused by fluorescent lamps and even sometimes by incandescent lamps. In ships the metal rigging can also act as a source of noise particularly when loose or dirty contacts are present. These can give rise to noise even in the absence of the strong electromagnetic fields necessary to cause the well-known rusty-bolt effect.

Appendix A.

5. It is impossible to set any value on the level of man-made noise-present in any situation, and for this reason it is difficult to allow for its effect on any communications link.

Atmospheric noise

6. If a receiver is operated in a situation free from man-made noise, it will be found that atmospheric noise predominates at frequencies up to about 10 Mc/s. Atmospheric noise is due to radiation from distant lightning flashes. Interference from nearby flashes takes the form of a separate and distant "crash", but the radiation from all the more distant thunder storms (and there are about two thousand of them taking place in various parts of the world, every day) adds up to a general background level which, over any comparatively narrow band of frequencies, has the random distribution of amplitude and frequency which is characteristic of noise.

7. The level of atmospheric noise at any frequency depends on the time of day, season of the year, weather and geographical location. For a naval communications system which may be required to operate under all conditions and in any part of the world, it is wise to allow for the maximum atmospheric noise level. The maximum noise level decreases with increasing frequency, and between 10 and 20 Mc/s the level of atmospheric noise becomes comparable with that of cosmic noise.

Cosmic noise

8. Cosmic noise, sometimes referred to as galactic noise, arrives at the earth's surface from all directions in space. If, however, a highly directional aerial is used to receive cosmic noise, it is found that the noise level varies markedly as the aerial is pointed at different regions of the sky. More noise arrives from the direction of the plane of our galaxy (i. e. in the direction of the Milky Way) than from a direction perpendicular to it. In addition it is found that there are certain discrete points in space which radiate more noise than their immediate surroundings. These point sources have become known as radio stars, and their study forms an important branch of the new science of radio astronomy. The sun, and, to a lesser extent, the extra-galactic nebulae also contribute to the overall cosmic noise level.

9. Naval mobile communications in general use omnidirectional aerials and hence it is only necessary to know the average cosmic noise level at any frequency. It is found that the level falls off steadily from 10 Mc/s, where it first becomes distinguishable from atmospheric noise, to 200 Mc/s, where it becomes comparable with receiver noise. Over the range 20 Mc/s to 100 Mc/s cosmic noise in general predominates in any system using non-directional aerials.

INTERNALLY-GENERATED NOISE

10. If it were possible to screen a high-gain receiver and its aerial from all sources of externally-generated noise there would still be noise present in the output. This noise has its origin in three sources:-

- (a) Thermal noise from the aerial.
- (b) Thermal noise from the input circuits.
- (c) Noise generated in the first valves.

11. These sources of noise call for a signal above a minimum strength if it is to be of use in the receiver (even in the absence of all externally generated noise). Thermal noise from the aerial is inevitably associated with the signal and is inseparable from it. The amount of the contribution from the receiver circuits and valves to the receiver output noise depends on the receiver design and to some extent on the frequency.
12. From a noise point of view the "goodness" of a receiver can be defined, with certain qualifications, as the ratio of the total output noise power to that part of it which is derived from the thermal noise of the aerial. This measure of the goodness of the receiver is known as the receiver noise factor. A good receiver will have a low noise factor, that is, most of the output noise is derived from the aerial; a bad receiver will have a high noise factor, most of the output noise being generated in the receiver itself. Up to about 2 Mc/s the noise factor of a receiver can be made approximately equal to unity; i. e. the receiver is indistinguishable, in this respect, from one that is perfect. Receiver noise factor increases as the frequency is increased; at 500 Mc/s a noise factor of ten is quite normal, though much lower figures have been reported from various laboratories.

#### CONCLUSIONS

13. In a communications system using a transmitter of given power and a receiver having adequate gain, the signal-to-noise ratio at the receiver output terminals is determined by the level of noise appearing at the receiver input terminals. (For the purpose of discussion, the internally-generated noise may be treated as though it appeared at the input terminals.) For any particular service there is a certain minimum useful signal-to-noise ratio. The limit of useful range will be set by the receiver input noise level.
14. At frequencies up to 10 Mc/s the receiver input noise level is determined by atmospheric noise. It should be noted however that variations up to 100 dB in the level of atmospheric noise have been recorded. Between 10 Mc/s and 100 Mc/s the input noise level is determined largely by cosmic noise. With omnidirectional aerials the cosmic noise level is reasonably constant at any particular frequency. Above 100 Mc/s the noise level is determined increasingly by the internally generated noise. Hence we see the necessity of striving to obtain the best noise factor for receivers in the VHF and UHF bands. It is equally important that the noise factor should not be allowed to deteriorate in service. For receivers working below 100 Mc/s the noise factor is less important. It is merely necessary to ensure that the internally generated noise does not constitute more than a small fraction of the total output noise power.
15. Noise from the sources dealt with above is inescapable, or only partly reducible, and sets an upper limit to the usefulness of any given communication system. In fact, it may not always be possible to reach this limit because of man-made noise or interference from unwanted signals.
16. It should be stressed that the foregoing is a greatly simplified treatment of noise problems. In particular the frequencies quoted must be treated only as rough approximations, as it is impossible to quote an exact frequency at which any change takes place. Noise factor is only one of many parameters required in any particular receiver and it may not always be possible to achieve the best noise factor because of conflict with these other parameters, or, in some cases, for economic reasons.



A P P E N D I X ' B '

T H E T H E O R Y O F

N O I S E F A C T O R M E A S U R E M E N T

L I S T O F C O N T E N T S

	<u>Paragraph</u>
Definition of Noise Factor	1-2
Thermal Noise	3-7
Receiver Noise	8-9
The Temperature - Limited Diode as a Source of Noise	10-14
Noise Factor Measurement: Receivers having Linear Detectors	15-18
Noise Factor Measurement: Receivers having Non-Linear Detectors	19-21
Advantages and Disadvantages of a Noise Generator.	22



A P P E N D I X ' B 'T H E T H E O R Y O FN O I S E F A C T O R M E A S U R E M E N TDefinition of Noise Factor

1. The noise factor of a receiver may be defined as the ratio of the total noise-power output to that part of it which is due to the thermal noise of the source circuit treated as a passive network at 290°K.
2. This definition applies to those parts of the receiver in which there occur only linear amplification, linear detection, and linear frequency conversion (if used). In effect, the source is a resistor at 290°K (i.e. at room temperature on the Kelvin scale); the choice of this temperature is arbitrary but is generally accepted.

Thermal Noise

3. The open-circuit noise voltage appearing across any resistor, due to the random motion of the electrons within it, is  $\sqrt{4KTBR}$ ,

where  $K = \text{Boltzmann's Constant} = 1.38 \times 10^{-23} \text{ joules/}^\circ\text{K}$   
 $T = \text{absolute temperature in } ^\circ\text{K (i.e. } ^\circ\text{C} + 273)$   
 $B = \text{bandwidth of measuring device in c/s}$   
 $R = \text{ohmic value of resistor.}$

4. The noise voltage contains components at all frequencies within the bandwidth of the measuring device. If the resistor is connected to a load, the noise voltage will cause a noise current to flow through the circuit thus formed and noise power will be dissipated in the load.
5. The maximum power which can be dissipated in a load is that dissipated in one whose impedance matches that of the source; in this case, a resistor of value  $R$ . The noise current flowing through such a matched load is  $\frac{\sqrt{4KTBR}}{2R}$ ,

and the power ( $p_s$ ) dissipated in the load is  $\left[ \frac{\sqrt{4KTBR}}{2R} \right]^2 R = KTB$ .

6. The expression  $KTB$  (which is independent of the value of  $R$ ) is known as the available noise power of the source.
7. If a resistor is connected across the input circuit of a receiver, the noise-power input will be amplified and will appear at the receiver output as a power  $P_s$ . The power gain ( $G$ ) of the receiver may then be defined the ratio  $P_s/p_s$ ; the effect of any mismatch existing between the source and the receiver is thus included in the value of  $G$ . (In the formulae given above, the bandwidth  $B$  is now that of the receiver.)

Receiver Noise

8. In any practical receiver, the noise-power output will be greater than that due to the thermal noise from the source. The first circuits and valves inevitably produce noise which is amplified and appears at the output.
9. Let the power output due to the receiver-generated noise be  $P_R$ . Then the total noise-power output ( $p_t$ ) is  $P_S + P_R$ .

The definition of noise factor (F) may thus be written

$$F = \frac{P_S + P_R}{P_S}$$

The Temperature - Limited Diode as a Source of Noise

10. In order to measure the noise factor of a receiver, another source of noise is required, the output from which can be compared with the thermal noise of the resistor source plus the receiver noise. For this purpose, a diode (in which the electron stream is obtained from a heated tungsten filament) is connected across the resistor source. In such a diode, provided that the anode voltage is greater than a certain critical value, all the electrons emitted by the filament will be attracted to the anode. Any increase in the anode voltage over this critical value will not result in any increase in the flow of electrons. Under these conditions, the electron flow (and hence the anode current) is governed solely by the temperature of the filament; if the filament temperature is increased, the anode current rises. The diode is then said to be temperature-limited.
11. A meter connected in the anode circuit of a temperature-limited diode indicates a steady value of anode current if the filament temperature is constant. Associated with this steady current, however, there are minute random fluctuations; these are due to variation from instant to instant in the number of electrons leaving the filament. These fluctuations are not detectable on the anode-current meter, but after amplification (in a receiver, for example) can operate an output meter.
12. This shot noise, as it is called, is similar in character to thermal noise. Shot noise is also generated in valves operating normally (i.e. not in the temperature-limited condition), but to a much lesser extent; the irregularity in electron flow in the valve is reduced considerably by the space-charge surrounding the cathode.
13. It can be shown that the noise current ( $i_n$ ) generated by a temperature-limited diode is  $\sqrt{2eIB}$

where  $e$  = electronic charge =  $1.60 \times 10^{-19}$  coulombs  
 $I$  = anode current in amperes  
 $B$  = bandwidth of measuring device in c/s.

14. The available power ( $p_n$ ) of a resistor of  $R$  ohms in parallel with a diode generating a noise current  $i_n$  is given by the formula

$$\begin{aligned} p_n &= \frac{i_n^2 R}{4} \\ &= \frac{1}{2} e I B R \end{aligned}$$

(This is in addition to the thermal noise power from the resistor itself). The noise-power input to a receiver due to the noise diode will be amplified and will appear at the receiver output as a power  $P_N$ , where  $P_N = G_p p_n$ .

### Noise Factor Measurement: Receivers having Linear Detectors

15. The noise-power output from the receiver is first measured with the temperature-limited diode and the resistor connected across the receiver input circuit, with zero diode anode current. The noise-power output ( $P_1$ ) is  $P_S + P_R$ , as given in Para. 9.
16. The diode anode current is increased until the receiver noise-power output is  $P_2$ . In practice it is found convenient to double the power, i.e. to make  $P_2 = 2P_1$ , but in order to derive a general formula for noise factor, it is assumed that  $P_2 = mP_1$ .

$$P_2 = P_S + P_R + P_N$$

$$\text{Thus } m = \frac{P_2}{P_1} = \frac{P_S + P_R + P_N}{P_S + P_R}$$

$$= 1 + \frac{P_N}{P_S + P_R}$$

$$\therefore P_S + P_R = \frac{P_N}{m - 1}$$

$$\text{Hence } F = \frac{P_S + P_R}{P_S} = \frac{P_N}{P_S(m-1)}$$

$$= \frac{G_p p_n}{G_p p_s(m-1)}$$

$$= \frac{p_n}{p_s(m-1)}$$

$$= \frac{\frac{1}{2} e I B R}{K T B(m-1)}$$

$$= \frac{e I R}{2 K T(m-1)}$$

17. Assuming that the power-doubling procedure is used (i.e.  $m=2$ ) and that  $T = 290^\circ \text{K}$ , the formula derived in Para. 16 becomes  $F = 20IR$  on substitution of the values of the constants; expressing noise factor in decibels,

$$F = 10 \log_{10} 20IR$$

18. The measurement of noise factor using a diode noise source thus resolves itself into the measurement of a d.c. current. If the value of  $m$  is kept constant for all measurements, it is possible to calibrate the diode anode-current meter directly in noise factor. The source resistor is made an integral part of the noise generator, and (for VHF use) precautions are taken to minimise any stray reactances, thus retaining the wide-band nature of the source.

Noise Factor Measurement: Receivers having Non-Linear Detectors

19. If the characteristic of a receiver second detector is not linear, but is known, it is possible to measure the noise factor of the receiver by the power-doubling method. In this case, the power-doubling must take place at the detector input, although the actual measurement of the output-power ratio corresponding to this condition is made at the receiver output. If the detector characteristic is not known, a slightly more complicated method of measuring noise factor must be adopted, as described below.

20. Let the receiver output with zero diode anode current result in a meter reading  $M_1$ . Let this reading rise to  $M_2$  when the diode anode current is increased to  $I_1$ . Then the ratio  $M_2/M_1$  represents the power ratio

$$\frac{P_S + P_R + P_{N1}}{P_S + P_R}$$

From the definition of noise factor,  $P_S + P_R = FP_S$

$$\text{Hence } \frac{P_S + P_R + P_{N1}}{P_S + P_R} = \frac{FP_S + P_{N1}}{FP_S}$$

$$\begin{aligned} &= \frac{F + \frac{P_{N1}}{P_S}}{F} \\ &= \frac{F + 20I_1 R}{F} \end{aligned}$$

21. If the i.f. gain of the receiver is reduced and two values of diode anode current  $I_2$  and  $I_3$  are found to give readings of  $M_1$  and  $M_2$  respectively, then the ratio  $M_2/M_1$  represents the power ratio

$$\frac{P_S + P_R + P_{N3}}{P_S + P_R + P_{N2}} = \frac{FP_S + P_{N3}}{FP_S + P_{N2}} = \frac{F + 20I_3 R}{F + 20I_2 R}$$

$$\therefore \frac{F + 20I_1 R}{F} = \frac{F + 20I_3 R}{F + 20I_2 R}$$

$$\text{or } F = \frac{20I_1 I_2 R}{I_3 - I_2 - I_1}$$

$$\text{In decibels, } F = 10 \log_{10} \frac{20I_1 I_2 R}{I_3 - I_2 - I_1}$$

For accurate results using this method,  $M_2$  should be at least 1.5 times  $M_1$ , and  $I_3$  should be substantially greater than  $(I_2 + I_1)$ .

Advantages and Disadvantages of a Noise Generator

22. These are summarised below:

- (a) A noise generator is cheap, robust and portable.
- (b) The noise power is generated at a low level; there is thus no need for the complicated screening necessary on signal generators.
- (c) The accuracy of the output voltage calibration of a signal generator is often in doubt. The measurement of noise factor depends ultimately on the measurement of a d.c. current, usually of the order of 10 mA, which can be effected simply and reliably.
- (d) It is unnecessary to tune the noise generator to the receiver channel frequency, since the former is a wide-band source.
- (e) VHF narrow-band receivers having crystal-controlled local oscillators depend for their proper operation on the alignment of the i.f. amplifier to the correct frequency. A noise generator will not reveal any deficiency in this respect.
- (f) An independent check of the gain of the receiver must be made.



APPENDIX 'C'

NOISE GAIN AND ITS USE AS A MEASURE OF  
COMMUNICATION RECEIVER PERFORMANCE

LIST OF CONTENTS

	<u>Paragraph</u>
Introduction	1-3
The Relationship between Noise Gain, Noise Factor and Noise-Power Output	4-8
Interpretation of Test Figures	9-14



APPENDIX 'C'NOISE GAIN AND ITS USE AS A MEASURE OF  
COMMUNICATION RECEIVER PERFORMANCEIntroduction

1. A noise generator can be used for planned maintenance routines to check, by direct measurement, the noisiness and overall gain of a receiver, and, by implication, the receiver bandwidth.
2. The value of the noise factor indicates the noisiness of the receiver. If the noise factor is poor (i.e. high), excessive internal noise is being generated, and very weak signals which would normally be received are lost below the noise level. The value of the noise-power output from the receiver is dependent upon the gain, but is also related to the noise factor.
3. By recording the figures obtained each time the receiver is tested, the trend of receiver performance can be observed; when the performance has deteriorated beyond the specified limit, or a marked change in performance occurs, the receiver should be taken out of service.

The Relationship between Noise Gain, Noise Factor and Noise-Power Output

4. The definition and theory of noise factor are given in Appendix 'B', to which reference should be made.
5. It is permissible to consider all the noise produced within a receiver as though it existed at the receiver input; let the noise power be  $p_n$ . This noise-power receives the full amplification of the receiver, and hence appears at the output as a power  $p_n \cdot G$ , where  $G$  is the power gain of the receiver.
6. The total noise power at the receiver output due to the thermal noise of the source plus the receiver noise is  $(KTB + p_n)G$ . The definition of noise factor ( $F$ ) may thus be written

$$F = \frac{(KTB + p_n)G}{KTB \cdot G} = \frac{KTB + p_n}{KTB}, \text{ and hence}$$

noise factor is independent of receiver gain. (The formulae in this paragraph are different forms of the formulae given in Appendix 'B' Para. 9.)

7. The ratio of noise-power output to noise factor is

$$\frac{(KTB + p_n)G}{\frac{KTB + p_n}{KTB}} = KTB \cdot G$$

Since  $KTB$  is a constant for any given receiver (provided that the bandwidth remains approximately correct), the ratio of noise-power output to noise factor is proportional to the power gain. Expressing the quantities in decibels, the relationship becomes:-  
noise-power output minus noise factor = power gain plus a constant.

8. Since consideration is being given to the amplification of noise only, it is convenient to refer to the power gain of the receiver in these circumstances as the noise gain.

Interpretation of Test Figures

9. The Noise Generator CT 82 can be used to measure the noise factor and noise-power output of a receiver. From the values obtained, a figure for noise gain can be calculated from the equation given in the last sentence of Para. 7.

10. The figure for noise gain is not an absolute one, since the Noise Generator OUTPUT METER is calibrated in decibels with respect to a purely arbitrary reference-level; in view of this, it is convenient to ignore the constant in the equation. Consequently, it is often found that the figure obtained for noise gain is negative. This is of little consequence as it is the variation of noise gain which is of most interest.

11. The initial value of noise gain is obtained when the receiver is first installed and is known to meet the specified requirements. Later measurements will indicate either no material change in noise gain or else a trend away from the normal value.

12. The table below gives four examples of possible changes in receiver performance.

Noise-Power Output (dB)		Noise Factor (dB)		Noise Gain (dB)	Condition
8	minus	12	=	-4	} Noise factor increasing. Gain decreasing.
8	"	13	=	-5	
8	"	14	=	-6	
8	"	12	=	-4	} Noise factor increasing. Gain remaining normal.
9	"	13	=	-4	
10	"	14	=	-4	
11	"	15	=	-4	
8	"	12	=	-4	} Noise factor steady. Gain increasing.
9	"	12	=	-3	
10	"	12	=	-2	
11	"	12	=	-1	
12	"	12	=	0	
13	"	12	=	+1	
14	"	12	=	+2	
8	"	12	=	+4	} Noise factor steady. Gain decreasing.
7	"	12	=	+5	
6	"	12	=	+6	

13. The great advantage of using noise gain instead of noise-power output as an indication of receiver sensitivity is that noise gain takes noise factor into account.
- (a) A receiver had a noise factor of 14 dB and a noise-power output of 8 dB, hence the noise gain was -6dB. As a result of a sudden deterioration of the first r.f. valve, the noise factor increased to 17 dB and the noise-power output decreased to 7 dB. The noise gain thus decreased to -10 dB, indicating that the receiver gain fell by 4 dB, whereas the reduction in noise-power output was only 1 dB.
  - (b) Two receivers each have a noise-power output of 0.5 dB, but the noise factor of receiver A is 18.5 dB and that of receiver B only 13 dB. Hence the noise gain of receiver A is -18 dB and that of receiver B is -12.5 dB. Thus although the noise-power output is the same in both cases, the gain is quite different.
14. Note:- The noise-signal injected into a receiver from the Noise Generator uses the whole bandwidth of the receiver, and thus the results of the tests on the receiver will depend upon the receiver bandwidth, as well as upon the factors already considered. It has been found by experiment that a small change in bandwidth, or in alignment which distorts the response curve, results in an appreciable change in noise gain. If noise gain changes, and normal fault-finding methods are unsuccessful, then it is possible that realignment may be necessary. To prove that misalignment does in fact exist, checks may be carried out using a signal generator; reference should be made to the relevant equipment handbook.



This file was downloaded  
from the RTFM Library.

Link: [www.scottbouch.com/rtfm](http://www.scottbouch.com/rtfm)

Please see site for usage terms,  
and more aircraft documents.

