

Chapter 13

PONCHO CAPE

LIST OF CONTENTS

	<i>Para.</i>
<i>Introduction</i>	1
<i>Description</i>	2
<i>Operation</i>	
<i>Roles</i>	4
<i>Servicing</i>	7
<i>Folding</i>	8

LIST OF ILLUSTRATIONS

	<i>Fig.</i>		<i>Fig.</i>
<i>Poncho cape</i>	1	<i>Folding details</i>	2

LEADING PARTICULARS

<i>Poncho cape, complete</i>	<i>Ref. No. 22P/27</i>
<i>Dimensions (unfolded)</i>	96 in. × 88 in.
<i>(folded)</i>	<i>approx. 15 in. × 3 in. × 1.75 in.</i>
<i>Retaining bands (2 off) KRAFT, paper gummed tape,</i> 2.5 in. wide, CS.2564	

Introduction

1. Made from single ply rubber-proofed silk, the poncho cape (*fig. 1*) is primarily designed to serve as a cape, tent, ground sheet and ground marker. It can be worn with either side outermost. When not in use, the cape can be retained in a folded condition (*fig. 2*) by two bands of 1½ in. wide tape.

Description

2. The cape is rectangular in shape and consists of a number of panels joined to-

gether by adhesive solution. A centrally positioned aperture is edged with elastic binding and a draw string housing. A series of nylon cord loops, equidistantly spaced between corner loops, are secured to the outer edges of the cape.

3. One side of the cape is coloured dark-earth, and the opposite side is coloured alternate fluorescent flame orange and fuchsia. This fluorescent colouring is an aid in rescue work by making for easier detection at long distances.

R E S T R I C T E D



Fig. 1. Poncho cape

Operation

Roles

4. When worn as a cape, the draw string should be loose and the central aperture enlarged sufficiently to permit insertion of the wearer's head.
5. When filling the role of a tent, the cape can be attached by the draw string, to a pole, tree branch or other available object of satisfactory height and shape. The edges of the cape can be anchored, by the loops, to ground pegs or to suitably weighted objects.
6. When filling the role of a ground marker,

the cape should be laid out horizontally, fluorescent side uppermost, and the loops secured to ground pegs or other suitable objects.

Servicing

7. Servicing is to be carried out in accordance with the instructions given, and at the periods stated, in Vol. 4.

Folding

8. Fig. 2 illustrates the complete sequence of operations for folding the cape. Throughout the folding operations, the proofed side of the cape must be on the outside.

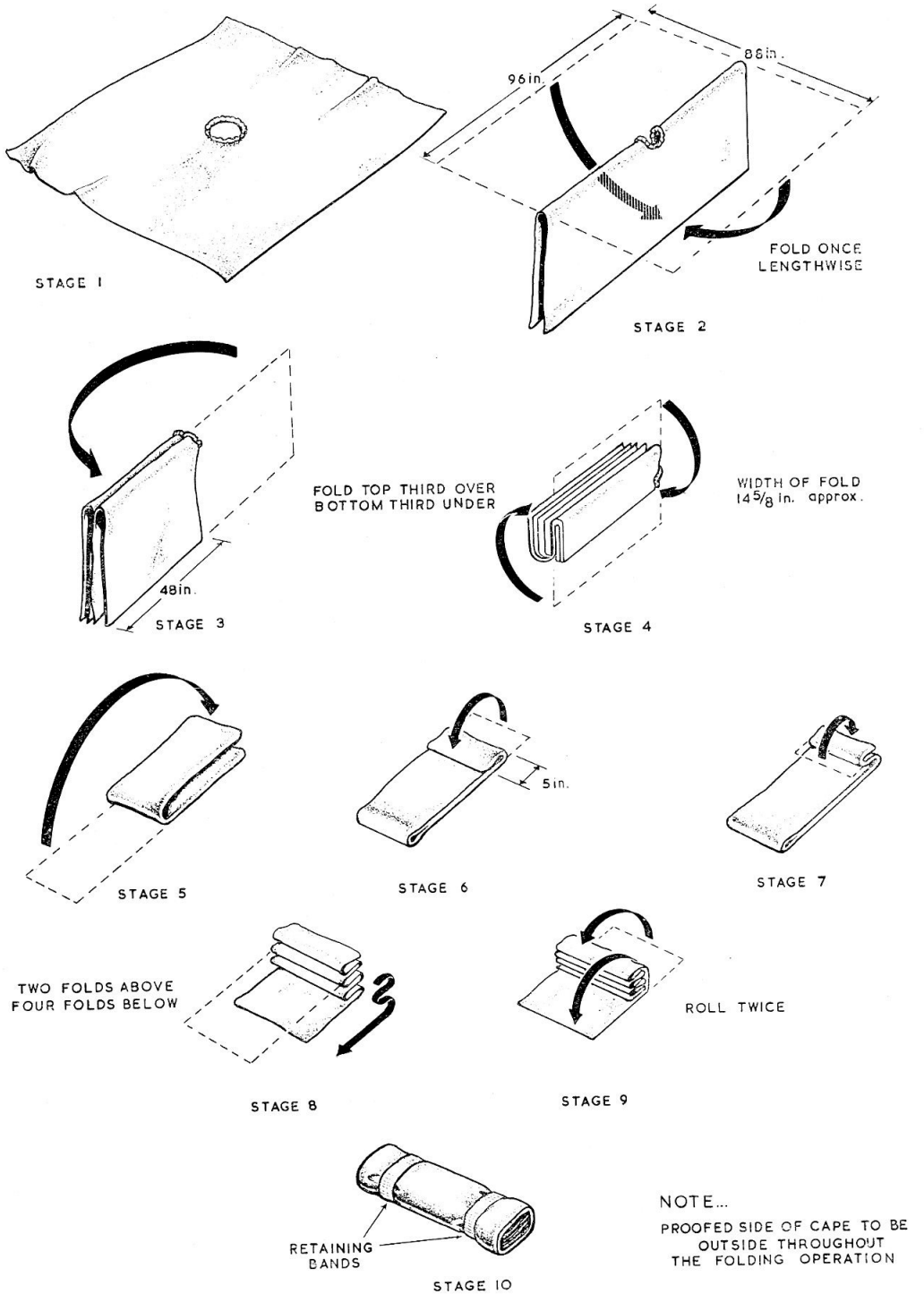

Fig. 2 Folding details

RESTRICTED