

Chapter 1

LIGHTNING F MK 1 AND F MK. 1A

LIST OF LETTERED ADDENDA  
(EJECTION SEAT MK. 4BS)

*Mod No.*

*Addendum*

2690

*Introduction of downward pull  
negative-G restraint strap*

A

RESTRICTED

## Chapter 1

## LIGHTNING F MK. 1 AND F MK. 1A

## LIST OF CONTENTS

	Para.		Para.
<i>Introduction</i> ... .. .	1	<i>Equipping the seat</i> ... ..	16
<i>Composition of the assembly</i> ... ..	2	<i>Strapping-in procedure</i> ... ..	18
<i>The Type 4 BS ejection seat and associated equipment</i> ... ..	3	<i>Emergencies</i> ... ..	19
<i>Connections to the aircraft</i> ... ..	15	<i>Leaving the aircraft after landing</i> .. ..	20

## LIST OF ILLUSTRATIONS

	Fig.		Fig.
<i>Arrangement of oxygen supply on seat</i> .. ..	1	<i>The seat equipped (2)</i> .. ..	5
<i>Arrangement of drogue withdrawal and link lines</i> .. ..	2	<i>Arrangement of leg restraint cords</i> ... ..	6
<i>Arrangement of negative 'G' restraining strap on P S.P.</i> ... ..	3	<i>Arrangement of negative 'G' restraining strap to lap straps</i> ... ..	7
<i>The seat equipped (1)</i> .. ..	4	<i>The seat occupied (1)</i> ... ..	8
		<i>The seat occupied (2)</i> ... ..	9

## ◀ LIST OF APPENDICES ▶

	App.
<i>Flying clothing</i> .. ..	1
◀ <i>Aircraft fitted with Type 4 BS Mk. 2 ejection seats</i> .. .. ▶	2

## Introduction

1 This chapter is primarily concerned with the installation of equipment in or on the seats, preparation by the pilot for flying (dressing and function testing of the flying clothing), strapping-in procedure and the drill to be used when leaving the aircraft after landing. A brief description of the various components of the A.E.A. is included; full details will be found in the appropriate publications, a reference to which is contained in para. 14 and Appendix 1.

## COMPOSITION OF THE ASSEMBLY

2. The aircrew equipment assembly on the F Mk. 1A is identical with the F Mk. 1 and consists of the following items:—

Ejection seat	Type 4 BS
Parachute assembly	Back Type Mk. 28
Personal survival pack	Type V (c/w cushion)
Emergency oxygen set	Mk. 8B

RESTRICTED

Flying clothing assembly Refer to App. 1 for correct assembly to Sect. 1, Chap. 1.

### The Type 4BS ejection seat and associated equipment

3. The Type 4BS seat is ejected from the aircraft by a cartridge-operated gun at a speed of 80 ft./sec. and may be used for low level ejection in accordance with the instructions on the side of the drogue container, provided the airspeed is over 90 kt. and the aircraft flight path is straight and level. During ejection, the seat slides in two guide rails attached to the cylinder tube of the ejection gun; the rails are fitted with brackets which enable the gun to be bolted to the airframe structure.

4. The back type Mk. 28 parachute assembly incorporates a combined safety/parachute harness. The pack is housed in a parachute container introduced by Mod. ES.825, which forms an integral part of the seat back and the harness is attached to the seat by lugs at three quick-release points, one under the support bracket for the parachute pack and two at the back of the seat pan. These lugs may be separated from the seat by the action of a barostatic time-release unit, or by a manual separation lever on the left-hand side of the seat pan to the rear. Forward on the left-hand side of the seat pan is a "go-forward" harness release which, when the knob is pushed forward, releases the snub lever and allows the occupant to lean forward in the cockpit without separating the parachute assembly from its attachment points on the seat. Forward movement is only possible when the lever is held forward against the spring. When the lever is released, the occupant may maintain the forward position of the body, but on returning to the upright position, the spring will take up the slack and the snub lever locks the system against renewed forward movement.

5. Housed in the seat pan is a Type V personal survival pack, which with the cushion, forms a comfortable seat for the occupant. The pack is attached to the combined harness by side quick-release couplings and its lowering line is connected to the flying clothing during strapping in. A negative 'G' restraining strap (introduced by Mod. PA.69) is fitted over the pack between the bottom harness locks and an anchor bracket (introduced by Mod. ES.2102) is fitted on the inside of the seat pan behind the alternative

firing handle. This strap extends upwards from the bracket to the lap straps and when tightened prevents forward movement of the pack, cushion and occupant.

6. An emergency supply of oxygen is carried in a cylinder clamped to the right-hand side of the seat at the rear. The supply is automatically turned on during ejection, but provision is also made for manual operation in the event of failure of the main oxygen supply. A demand emergency oxygen set will be introduced in the near future as a replacement for the existing set; details will be included as soon as they are available.

7. A personal equipment connector (P.E.C.) described in Sect. 1, Chap. 5 is fitted to the right-hand side of the seat pan, enabling the main and emergency oxygen, air ventilated suit, anti 'G' suit and Mic/Tel services to be connected, or disconnected, in one action. The connector consists of the following items:-

- (1) *The aircraft component.* Connected to the cockpit floor by a static line, and to aircraft services for main oxygen, A.V.S., anti 'G' systems and Mic/Tel.
- (2) *The seat component.* Bolted to the seat pan and connected to the emergency oxygen set.
- (3) *The personal component.* Attached to the jerkin and oxygen hose assemblies.

8. An inward relief and excess pressure valve (Type RV51) is fitted to the rear of the P.E.C. The function of the valve is to prevent excessive pressure building up in the jerkin and partial pressure helmet, or oxygen mask, when the emergency oxygen supply is first turned on, as the emergency oxygen supply becomes exhausted, the valve opens to admit air as the user inhales. Owing to the need to overcome the spring loading of the valve, inhalation becomes noticeably more difficult as the oxygen supply becomes exhausted, thus giving warning of the impending lack of oxygen. When the demand E.O. set is used, this valve becomes redundant; the valve is described in Sect. 1, Chap. 6.

9. Two firing handles are fitted to the seat. The main handle, which has an integral face screen, projects from the front of the drogue container; the alternative firing handle is partly

recessed into the top front edge of the seat pan and is intended for use only when the occupant is unable to reach the main handle, e.g. when subjected to high 'G' forces. Both handles are connected to the hood jettison mechanism and, when either handle is pulled, the hood is jettisoned immediately, the seat being ejected after a delay of one second. A restrictor is fitted to the hood jettison firing unit to prevent operation of the ejection gun until the hood has been jettisoned. A separate hood jettison handle is also provided to enable the hood to be jettisoned with ejection taking place.

10. Leg restraint cords, fitted through snubbing units under the seat pan, ensure that the occupant's legs are drawn back to the seat pan and restrained there during ejection, thereby reducing the risk of injury. An interconnection between the leg restraint cords and the P.E.C. ensure that the cords cannot be connected until the personal component of the P.E.C. is correctly engaged with, and locked, to the seat component. If the personal component of the P.E.C. becomes disconnected in flight the leg restraint cords will be released.

11. Seat height adjustment is achieved by an electrically operated actuator. The switch for the actuator is mounted on the right-hand side of the seat pan, forward of the P.E.C. It is spring loaded to the central (OFF) position and operates in the natural sense i.e. a downward movement lowers the seat.

12. As the seat ascends the guide rails during ejection, the aircraft component of the P.E.C. is detached from the seat component, severing all connection between the seat and the aircraft services; at the same time, the emergency oxygen supply is turned on automatically.

13. Fully automatic facilities are provided to withdraw the parachute canopy from its pack and separate the occupant from the seat after ejection. Manual override controls, the first D-handle on the parachute harness waistbelt and the manual separation lever on the side of the seat pan, enable the occupant to disconnect the parachute automatic withdrawal device and the combined harness from the seat if the need arises to (a) make a manual bale-out or (b) make

a manual separation from the seat after ejection. The parachute is then deployed by operating the second D-handle on the waistbelt.

**Note . . .**

*The parachute automatic withdrawal device MUST first be rendered inoperative by pulling the first D-handle.*

14. A complete description of the ◀ Type ▶ 4 BS seat and personal equipment connector will be found in A.P.4288, Vol. 1, the parachute assembly and personal survival pack are described in A.P.1182A, Vol. 1 and A.P.1182C, Vol. 1 respectively

**Connections to the aircraft**

15. When the seat is installed in the aircraft and is properly equipped, the following items are connected to the aircraft:—

- (1) *Left-hand side of seat:—*
  - (a) Static rod from drogue gun
- (2) *Right-hand side of seat:—*
  - (a) Static rod from barostatic time-release unit
  - (b) Static line from aircraft component of P.E.C.
  - (c) Main oxygen supply hose
  - (d) Air ventilated suit air supply hose
  - (e) Anti 'G' suit air supply hose
  - (f) Mic/Tel lead
  - (g) Electrical lead to seat actuator
- (3) *Underside of seat:—*
  - (a) Leg restraint cords
- (4) *Top of seat:—*
  - (a) Hood jettison unit operating cable
  - (b) Static line from hood to restrictor

## EQUIPPING THE SEAT

16. Before equipping the seat ensure that it has been made safe for servicing in accordance with current instructions.

17 The following procedure is to be followed when installing the equipment in the seat; refer to fig. 1, 2, 3, 4 and 5 for details as necessary:-

- (1) Fit the emergency oxygen cylinder into its bracket on the rear of the seat pan, ensuring that the supply tube faces forward. Pass the supply tube through the hole in the right-hand side of the seat pan and connect it to the metal extension pipe fitted to the inward relief and excess pressure valve. Ensure that the emergency oxygen manual control knob is pushed down fully and connect the cylinder operating cable to the trip lever.

### Note

*The emergency oxygen set is more conveniently fitted before the seat is installed in the aircraft.*

- (2) Remove and retain the safety pin from the emergency oxygen cylinder operating head.
- (3) Ensure that the leg restraint cords are clear of the seat pan and that the seat pan is clean.
- (4) Place the parachute pack on its support bracket temporarily and ensure that the pack restraining straps and headrest cushion are immediately available.
- (5) Ensure that the harness straps are not twisted. Operate the harness 'go-forward' lever, pull out the strap under the support bracket and pass it ◀ downward ▶ through the harness D-shackle.
- (6) Lift the parachute pack forward (this may be done before pulling out the centre strap if more convenient), pass the pack restraining strap O-ring over the centre strap lug and insert the lug into the attachment point

below the bracket. Pull sharply on the harness to ensure that the lug is locked securely

- (7) Pass the pack restraining straps through the arch of the pack, replace the pack on its support bracket and ensure that the restraining straps are not twisted.
- (8) Position the headrest cushion centrally on top of the parachute pack and ensure that it is not inverted.
- (9) Pass the left-hand pack restraining strap through the loop in the drogue link line, through the buckle on the short strap at the left-hand side of the drogue container and then forward through the buckle on the left-hand side of the headrest cushion.

### Note .

*When passing the strap through the buckle on the short strap at the side of the drogue container, ensure that the strap passes through from the outside inwards.*

- (10) Pass the right-hand pack restraining strap through the buckle on the short strap at the right-hand side of the drogue container (refer to the note following sub-para. (9)) then forward through the buckle on the right-hand side of the headrest cushion.
- (11) Tighten the pack restraining straps, ensuring that the headrest cushion remains central on top of the parachute pack.
- (12) Connect the two halves of the drogue link line coupling, ensuring that the line passes under the left-hand pack restraining strap and UNDER THE DROGUE WITHDRAWAL LINE.
- (13) Fit the negative 'G' restraining strap as follows.-
  - (a) With the blue 'Y' strap removed, pass the buckle end of the white 'Y' strap through the anchor bracket inside the front of the seat pan from bottom to top.

Attach the straight section of the blue 'Y' strap to the buckle so that the free end is facing forward with the 'Y' section uppermost.

- (b) Place the personal survival pack in the seat pan and route the white 'Y' strap over the top of the personal survival pack to the rear bottom harness locks on the seat. Engage the looped ends of the strap over their respective bottom lock harness lugs and insert the lugs in the locks. Ensure that the straps lie flat across the pack.
- (14) Fit the cushion to the seat strap of the harness as follows:-
    - (a) Pass the strap under the cushion and locate in position with the two press-studded beackets.
    - (b) Pass the leather covered straps of the cushion through the webbing loops on either side of the personal survival pack from rear to front. Pass the leg straps of the combined harness up through the slot in the cushion and secure the cushion to the pack with the lift-the-dot fasteners at the front.
    - (c) Pull the negative 'G' restraining strap forward and upward through the bracket to settle the personal survival pack down in the seat pan.
  - (15) Connect the side quick-release couplings of the personal survival pack to their harness counterparts.
  - (16) Insert the harness sticker straps into the spring clips on the inside of the seat pan and ensure that they pass outside the personal survival pack side quick-release couplings.
  - (17) Place the harness straps in the stow-

age clips situated immediately below the windscreen arch under the cockpit coaming.

- (18) Remove the drogue gun safety lock pin.
- (19) Remove the safety pin from the ejection gun sear and hood jettison sear and insert the appropriate pin in the main firing handle lock.

### STRAPPING-IN PROCEDURE

18. The procedure for strapping-in is as follows, refer to fig. 6, 7, 8 and 9 for detail as necessary:-

- (1) Before entering the seat, ensure that the harness is securely attached to the seat by pulling on the straps individually at each attachment point.
- (2) Ensure that the main and alternative firing handle safety pins are inserted correctly.
- (3) Sit in the seat and adjust its height to approximately the middle position, this enables the alternative firing handle safety pin to be removed at a later stage without fouling the control column.
- (4) Remove the dust cover from the seat component of the P.E.C. and fit it into its stowage on the right-hand side of the seat pan.
- (5) Fit the personal component of the P.E.C. to the seat component and lift the handle upwards gently to ensure that it is locked. When checking that the personal component is locked, DO NOT DEPRESS THE RELEASE PLUNGER; it is only necessary to place one or two fingers under the handle and attempt to lift it.
- (6) Connect the personal survival pack lowering line to its corresponding fitting on the pressure jerkin or life jacket, as appropriate, and ensure that it passes outside the left leg.

- (7) Pass the left-hand leg restraint cord through the right leg garter D-ring and plug it into the socket above the left-hand snubbing unit. Pass the right-hand leg restraint cord through the left leg garter D-ring and plug it into the socket above the right-hand snubbing unit. Pull sharply on both cords to ensure that they are securely locked in their sockets (remember that unless the personal component of the P E.C. is securely fitted to the seat component the leg restraint cords cannot be secured in their sockets). It is not important which cord is secured first so long as the cords are not interlaced.

**Note . .**

*If the cords are not long enough, pull the ring of each snubbing unit and ease the cord forward. Slack can be taken up by pulling the cords backwards through the snubbing units.*

- (8) Adjust the leg restraint cords in the snubbing units to obtain the required range of leg movement.
- (9) Adjust the parachute back pad and the height of the lumbar cushion. Draw up the blue 'Y' section of the negative 'G' restraining strap and pass the appropriate looped ends over each lap strap; ensure that the adjustment buckle and short strap end face forward and that the 'Y' section lies flat against the inside of the thighs. Connect and tighten the harness lap straps ensuring that the right-hand strap passes outside the hoses from the personal component of the P E.C.

**Note**

- ◀ (1) *When connecting the first lug to the inertia proof quick-release fitting, turn the disc knob anti-clockwise until the yellow line co-incides with dots on the body and insert the lug. The remaining lugs are fitted without further manipulation of the disc knob.*
- (2) *When an inertia proof quick-release fitting is provided, the safety clip mentioned in sub-para. (11) is not required and will have been removed from the harness. ▶*

- (3) *The lap straps must be as tight as possible. To tighten these straps fully, it is necessary to relieve the tension in the 'standing' end of each strap (the ends carrying the buckles) otherwise the buckles become stiff. Pull on the 'running' end with one hand and push the webbing of the 'standing' end towards the buckle with the other; it may be necessary to do this several times before the straps are sufficiently tight and while it is being done the occupant should push himself well back into the seat.*

- (10) Pass the left leg loop upwards over the inside of the thigh and through the D-ring on the left lap strap (from the inside of the ring towards the outside of the leg). Bring the end of the leg loop over towards the quick-release fitting, pass the lug of the left shoulder strap through the leg loop (from the top downwards) and insert the lug into its appropriate slot in the quick-release fitting; snug the loop down over the lug. Repeat these operations for the right leg loop and shoulder strap.
- (11) Adjust the negative 'G' restraining strap as tight as possible and tuck the free end back under the elastic band. Fit the safety clip to the harness quick-release fitting.
- (12) Remove the safety pin from the alternative firing handle and place it in its stowage on the console.
- (13) Adjust the sitting height to the desired position (ideally the head should be located centrally against the headrest cushion).
- (14) Ensure that the shoulder straps pass under the folds of the life jacket or pressure jerkin stole; tighten the inner (BLUE) straps and then the outer (KHAKI) straps.

**Note .**

*It is undesirable to tighten these straps excessively since this action may arch the back and cause spinal*

*injury if ejection has to be undertaken. The inner straps should not appreciably, press down on the shoulders in ordinary conditions; equally there should be no slack, so that in inverted flight these straps can take some of the weight off the lap straps as the body tends to stretch. The outer straps should be similarly adjusted to prevent forward movement.*

- (15) Ensure that the oxygen supply is connected to the oxygen mask or partial pressure helmet and that chin straps (as appropriate) are securely fastened. Connect the Mic/Tel lead.
- (16) The safety pin from the main firing handle is to be removed and placed in the stowage on the console (this is normally done by a member of the ground crew; if one is not available, the pilot MUST remove and stow the pin prior to strapping-in).

### EMERGENCIES

19. Instructions for dealing with emergencies are contained in A.P.4700A-P.N (F Mk. 1) and A.P.4700F-P.N (F Mk. 1A), to which reference should be made as necessary.

### LEAVING THE AIRCRAFT AFTER LANDING

20. The following sequence should be adopted when leaving the aircraft after landing:—

- (1) Remove the safety pins from their stowage on the console, fit the short pin through the alternative firing

handle and hand the others to the ground crew member who will then fit the long pin through the main firing handle lock.

#### Note . . .

*If a ground crew member is not available, the pilot MUST fit the main firing handle safety pin before leaving the cockpit.*

- (2) Remove the safety clip from the harness quick-release fitting, operate the fitting, free the harness straps (including the negative 'G' strap) and return the fitting to the locked position. Stow the straps on the clips provided in the cockpit.

#### ◀ Note . . .

*When an inertia proof quick-release fitting is provided, a safety clip will not be fitted behind the disc knob. ▶*

- (3) Disconnect the personal component of the P.E.C. from the seat component; remove the dust cover from its stowage and fit it to the seat component.
- (4) Free the leg restraint cords from the garters.
- (5) Disconnect the personal survival pack lowering line from the life jacket or pressure jerkin, as appropriate.
- (6) Disconnect the Mic/Tel lead.
- (7) Climb out of the aircraft.

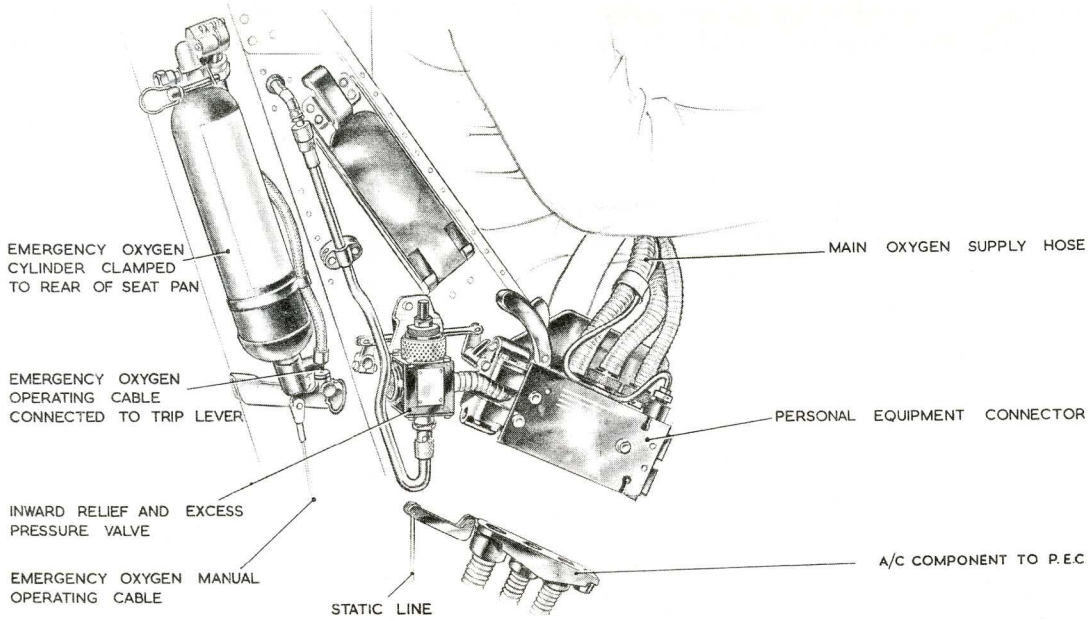

Fig. 1 Arrangement of oxygen supply on seat

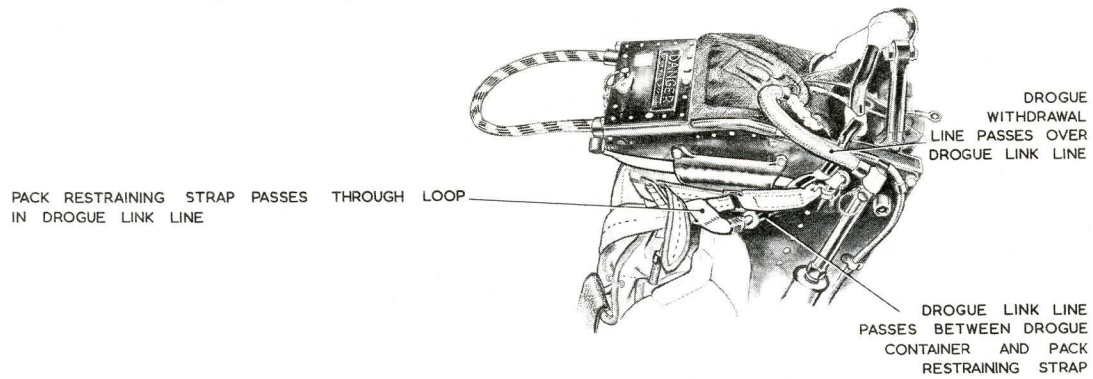

Fig. 2. Arrangement of drogue withdrawal and link lines

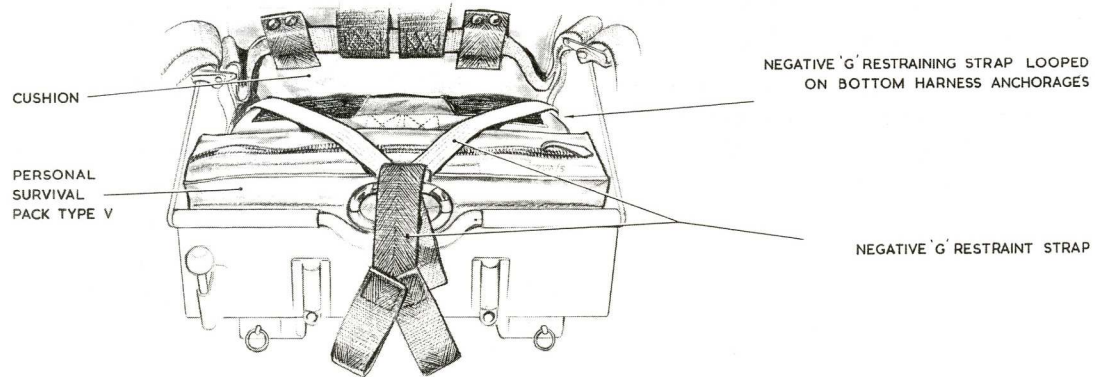

Fig. 3. Arrangement of negative 'G' restraining strap on P.S.P

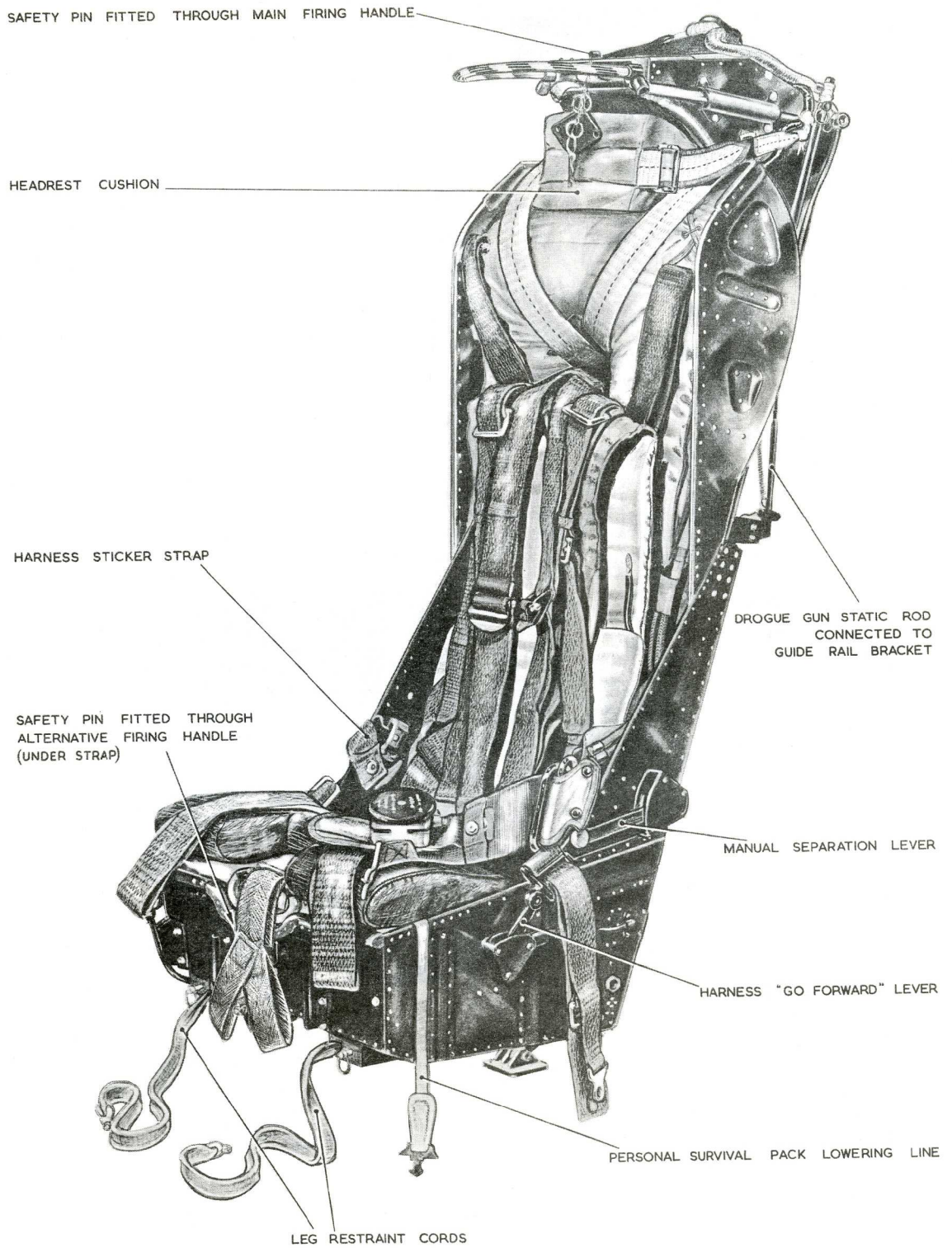

Fig. 4. The seat equipped (1)

RESTRICTED

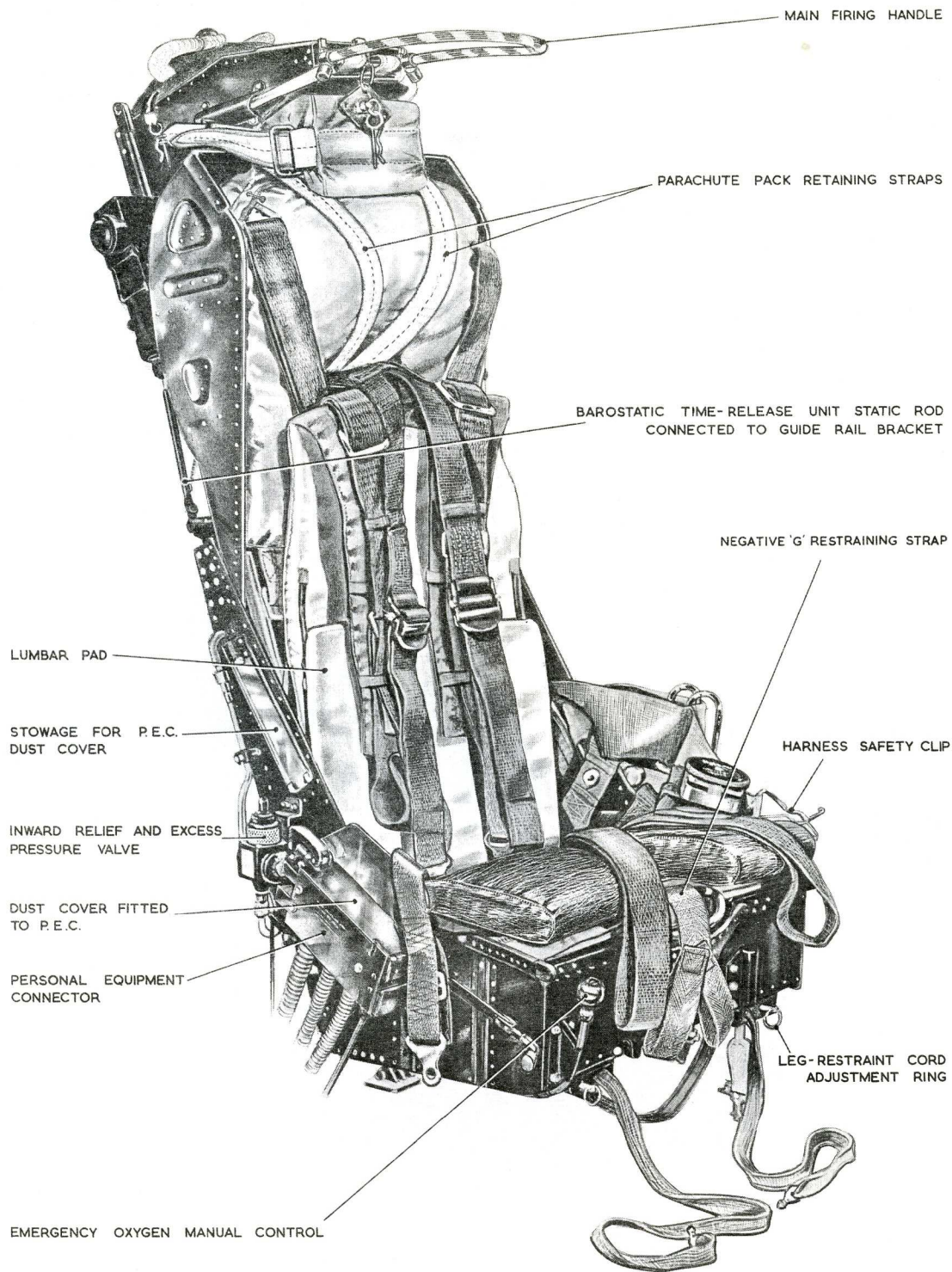

Fig. 5. The seat equipped (2)

RESTRICTED

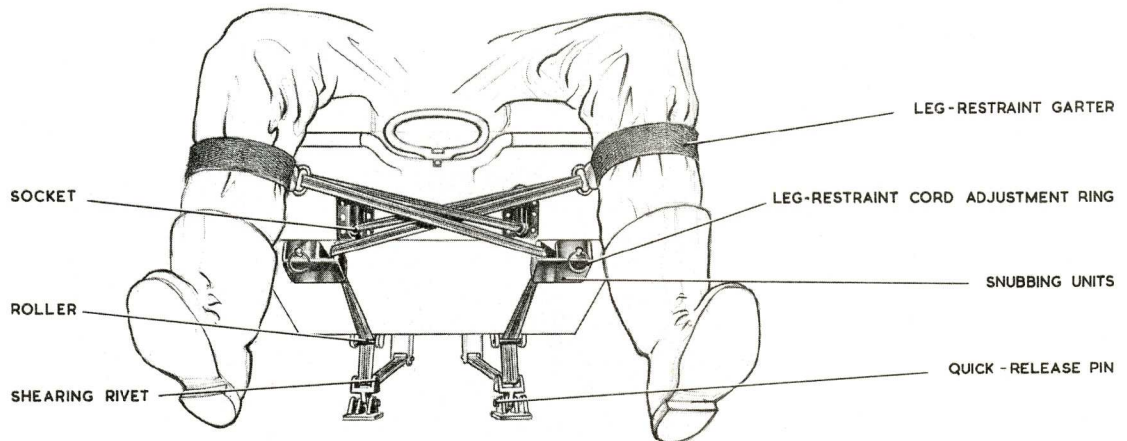

Fig. 6. Arrangement of leg restraint cords

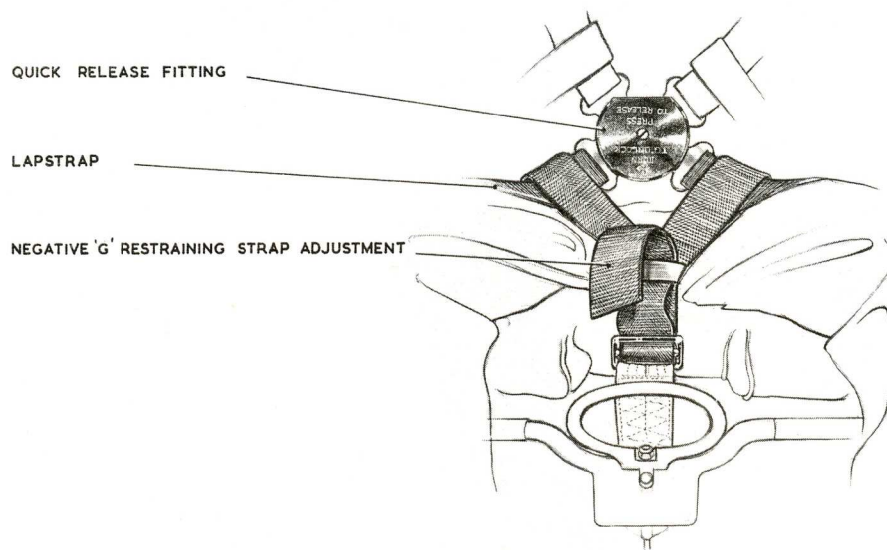

Fig. 7 Arrangement of negative 'G' restraining strap to lap straps

HEAD LEVEL WITH CENTRE OF HEADREST CUSHION

HARNES SHOULD STRAPS PASS UNDER FOLDS OF LIFE JACKET STOLE

SAFETY PIN REMOVED FROM ALTERNATIVE FIRING HANDLE

PERSONAL SURVIVAL PACK LOWERING LINE CONNECTED TO LIFE JACKET

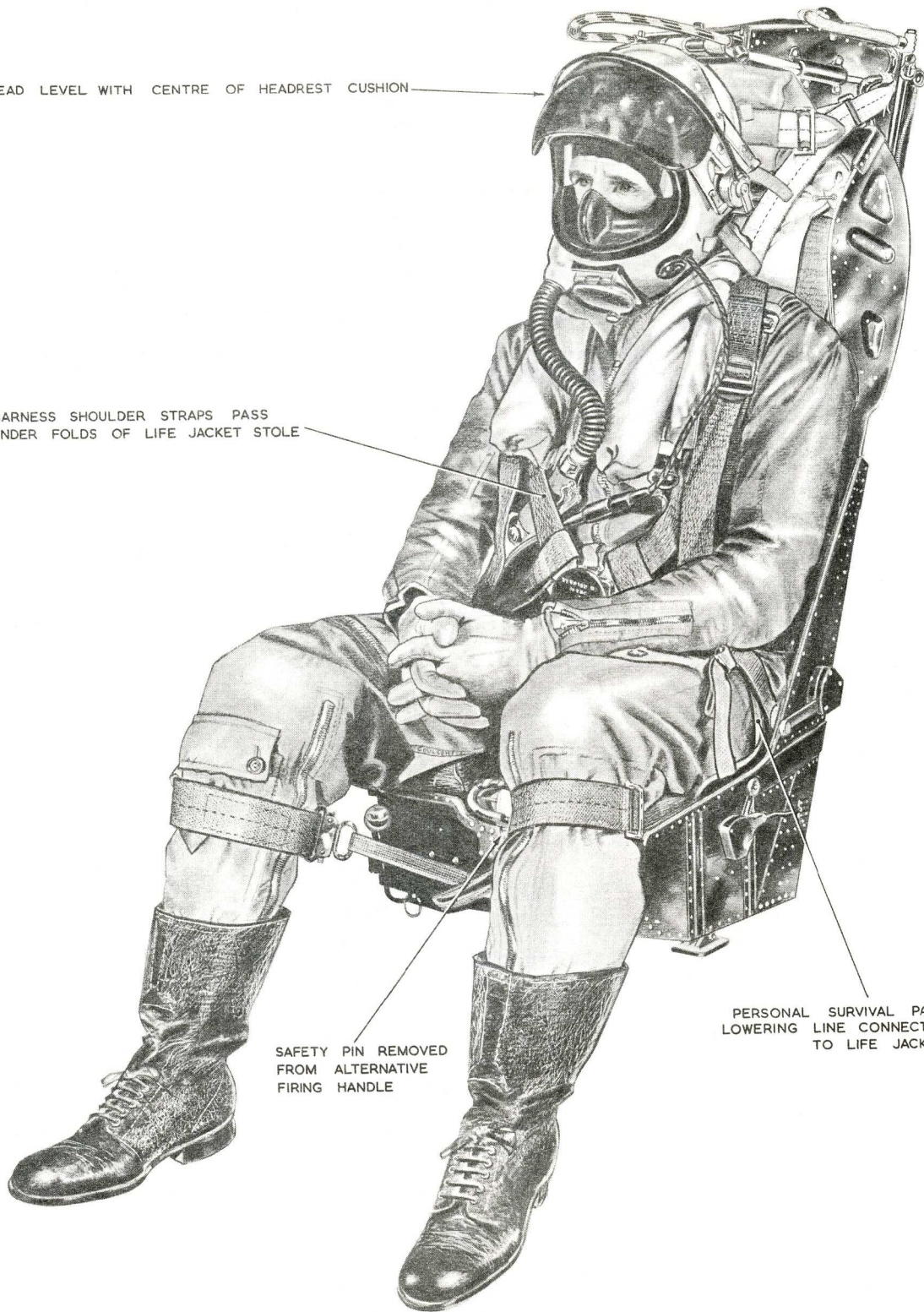

Fig. 8. The seat occupied (1)

RESTRICTED

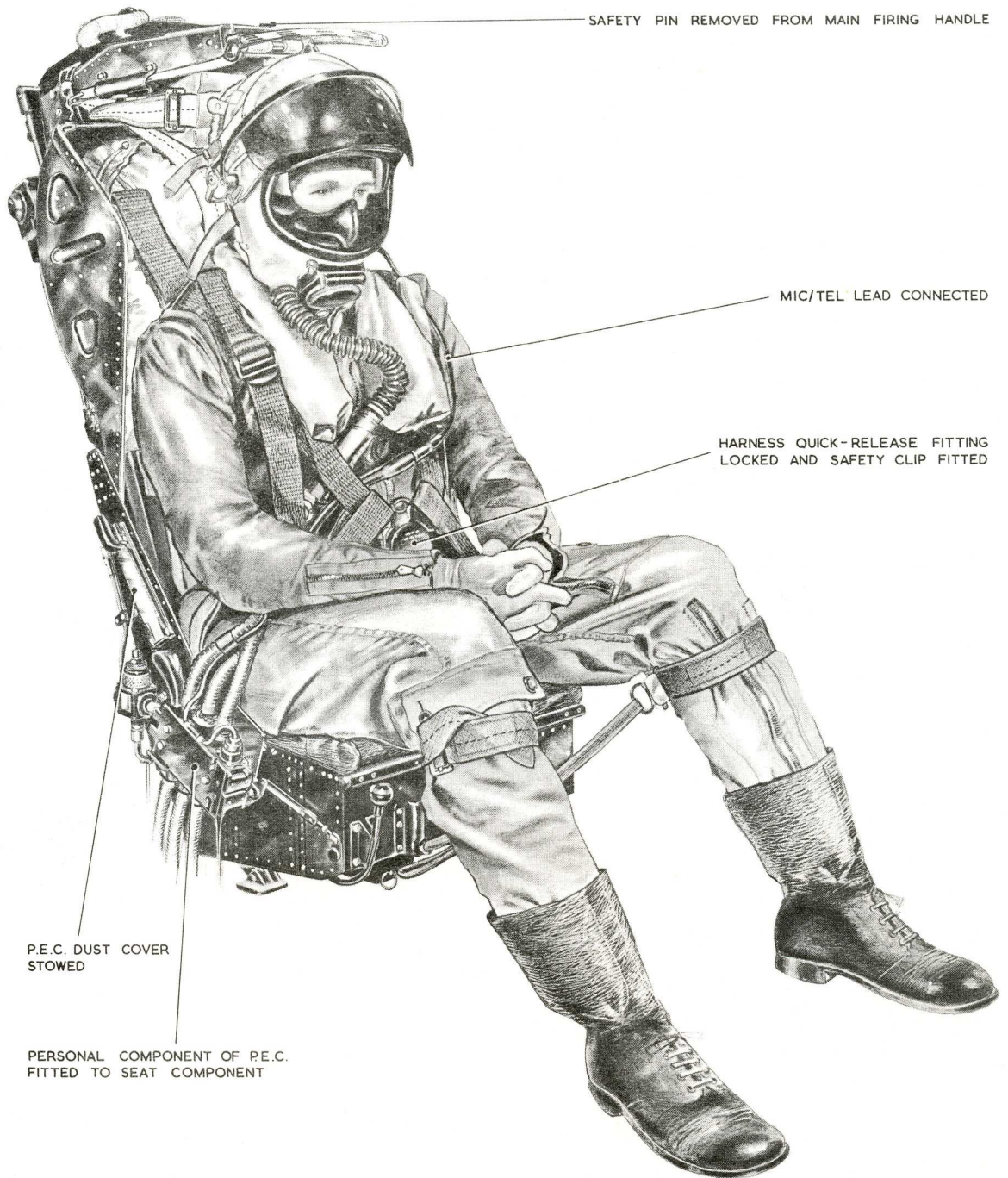

Fig. 9. The seat occupied (2)

RESTRICTED

## Addendum A

**EJECTION SEAT MK. 4BS MOD. NO. 2690**  
(Introduction of downward pull negative-G restraining strap)

1 Modification E.S. 2690 introduces a downward pull negative-G restraint strap in lieu of the upward pull strap introduced by modification P.A. 69.

2. When modification 2690 is embodied, the appropriate paragraphs and figures of Chapter 1 should be read as follows:-

(1) Para. 5.

Housed in the seat pan is a Type V personal survival pack, which with the cushion, forms a comfortable seat for the occupant. The pack is attached to the combined harness by side quick-release couplings and its lowering line is connected to the flying clothing during strapping in. A negative-G restraining strap which is tightened by a downward pull (introduced by modification E.S.2690) is fitted underneath the pack, the strap is passed through brackets attached to the floor of the seat pan and anchored to the rear harness attachment lugs and the lap strap lugs which fit into the harness quick-release box. When tightened, the strap restrains the occupant from vertical movement when subjected to high negative-G forces.

(2) Para 17 (13).

(a) Thread the white straps through the front bracket on the floor of the seat pan from front to rear, ensuring that the yellow tab on the buckle is facing forward. The white straps are marked 'PORT' and 'STAR BOARD' and it is essential that they are so positioned to ensure correct installation.  
(b) Pass the straps rearwards and thread each strap through its respective rear bracket in the floor of the seat pan.  
(c) Engage the looped end of each strap over its respective bottom lock harness lug and insert the lugs into their respective bottom locks. It may be necessary to partially depress the harness release lever beneath the barostatic time release unit to

facilitate insertion of the lugs. Check that they have locked correctly by pulling on the lugs.

(d) Drape the blue 'Y' piece of the negative-G strap OVER THE TOP of the seat pan firing handle.

(e) Lift the harness clear of the seat pan and insert the personal survival pack into the pan.

(3) Para. 17 (14)

Fit the cushion to the seat strap of the harness as follows:-

(a) Pass the strap under the cushion and locate it in position with the two press-studded becketts.

(b) Pass the leather covered straps of the cushion through the webbing loops on either side of the P.S.P from rear to front. Pass the leg straps of the combined harness up through the slot in the cushion and secure the cushion to the pack with the lift-the-dot fasteners at the front.

(4) Para. 18 (11).

Tighten the negative-G restraint strap by pulling DOWNWARDS on the free end of the blue strap until the strap is as tight as possible and ensure that the free end is then tucked down BEHIND the alternative firing handle. The strap is fitted with a snubber, which is released by pulling downwards on the yellow tab attached to the snubber lever, to loosen the strap.

(5) Fig.3. Arrangement of negative-G restraining strap on P.S.P Disregard Fig. 3 in Chapter 1 and refer to Fig. 1 of this addendum.

Fig.7 Arrangement of negative-G restraining strap to lap straps. Disregard Fig. 7 in Chapter 1 and refer to Fig. 2 of this addendum.

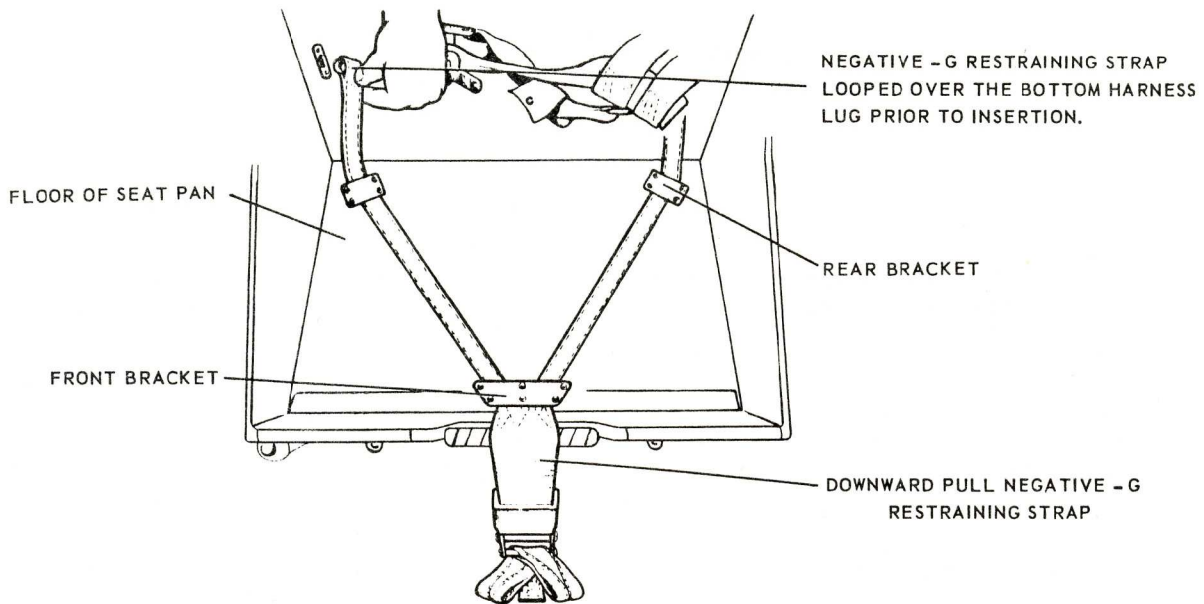

**Fig. 1 Arrangement of downward pull negative-G restraining strap in seat pan**

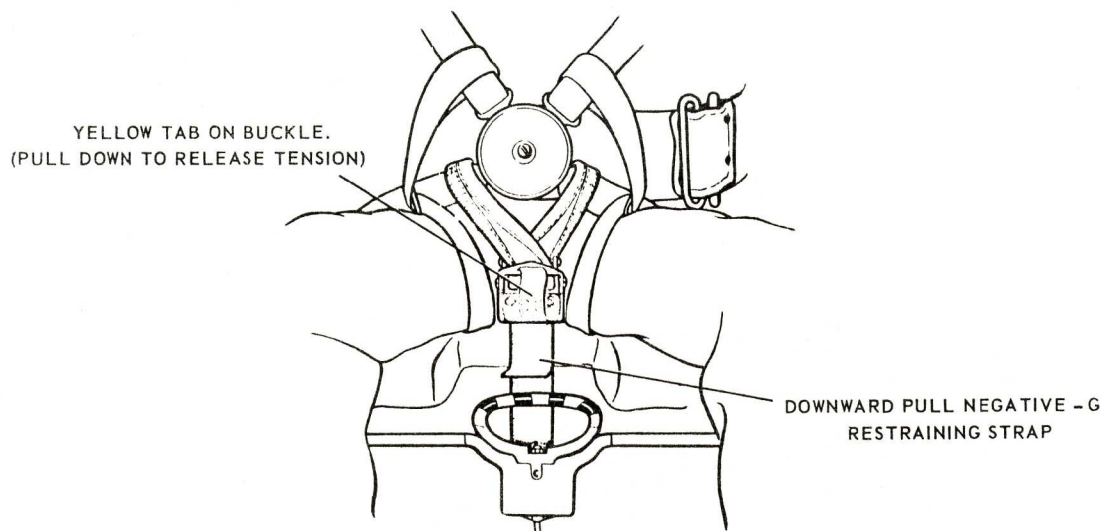

**Fig. 2 Arrangement of downward pull negative-G restraining strap to lap straps**

**RESTRICTED**

This file was downloaded  
from the RTFM Library.

Link: [www.scottbouch.com/rtfm](http://www.scottbouch.com/rtfm)

Please see site for usage terms,  
and more aircraft documents.

