

AUTOPILOTS AND AUTOSTABILIZERS

Purpose of an Automatic Pilot

1. On long flights, particularly during bad weather, it is desirable that the pilot should be relieved of much of the mental and physical fatigue of controlling the aeroplane. This is the primary function of an automatic pilot.

2. To be of any practical advantage, the mechanism must be able to perform all the controlling actions normally executed by the pilot. These actions can be defined under two basic headings :—

- (a) Actions necessary to fly the aircraft on a stabilized flight path.
- (b) Actions necessary to carry out accurate and automatically co-ordinated flight manoeuvres.

Stabilized Flight Control

3. Fig. 1 is a diagram of a basic autopilot installation. If such an installation is fitted in an aircraft flying straight and level and the aircraft is then subjected to a disturbance causing a nose-down attitude, the sensing device, which normally consists of a gyroscope mechanism, detects this change of attitude and also measures the magnitude of the change. The weak signal produced by the sensing device is fed into an amplifier, where it is boosted, and then passed to a servomotor which operates the appropriate control surface to restore the aircraft to its original attitude.

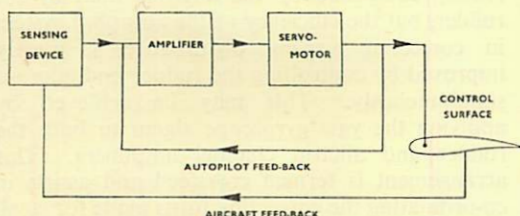

Fig. 1. Block Diagram of the Basic Autopilot Installation.

4. While the aircraft is responding to the corrective control movements and the attitude is changing back towards the original attitude, the

signal from the sensing device decreases until a condition is reached where the aircraft is once again flying straight and level with the control surface in the neutral position.

5. **Autopilot Feed-Back.** One other requirement should be considered at this stage, the provision of autopilot feed-back. Without feed-back there would be no balance between the amplifier output signal (and hence servomotor movement) and the magnitude of the original disturbance. The strength of the amplifier signal is related to the magnitude of the original disturbance by arranging that the servomotor feeds back to the amplifier a signal in opposition to the original control signal. When these signals are equal, movement of the servomotor ceases. Thus the servomotor movement is proportional to the original signal and hence to the aircraft displacement.

Flight Manoeuvres

6. To alter the flight attitude of the aircraft by means of the autopilot, use is made of the inherent characteristics of the system as explained earlier. A nose-down disturbance during flight is corrected by the application of up-elevator as a result of a signal which stems from the rotation of the aircraft about its pitch axis.

7. If, while flying straight and level, a simulated disturbance is applied to the input side of the amplifier, the servomotor operates to correct the simulated disturbance. This is achieved in the following way.

8. Assume that a pilot wishes to change from straight and level into climbing flight. If he injects into the amplifier a signal to simulate a nose-down condition, the autopilot would then function as if it were correcting a nose-down disturbance. Up-elevator would be applied, and the aircraft attitude would change in a nose-up direction, until the output signal from the sensing device (caused by the nose-up attitude) balanced the injected signal and reduced the amplifier input to zero; the two signals being then equal and opposite and the result a steady climb.

9. Although this is not the exact method employed for flight manoeuvres in all autopilots, the principle remains true. The method used on the Mk. 10 and 11 autopilots will be described later in this chapter.

fed to the servomotor. Some autopilots have an intermediate stage between the amplifier and servomotor, because, although the controlling signals are electrical, the servomotors may be hydraulically operated.

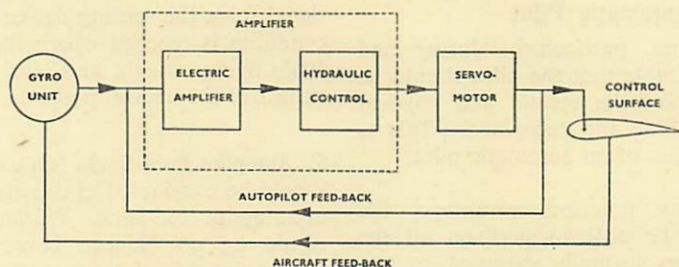

Fig. 2. Block Diagram of the Basic Mk. 11 Autopilot Installation.

Principles of Operation

10. The sensing device shown in Fig. 1 is the gyroscope unit which, in its simplest form, can be drawn as shown in Fig. 2A. If some form of pick-off (in this case a wiper attached to the gimbal system of the gyroscope) rests on a potentiometer winding that moves with the airframe, the wiper will maintain its datum position in space by virtue of the rigidity of the gyroscope. Any disturbance of the aircraft causing the potentiometer to move will also cause the position of the wiper on the potentiometer to change. (This is one of many such pick-off devices used.) When the gyroscope wiper is in the datum position the electrical signal to the amplifier is zero. Should the wiper move to one side of the datum position, however, a signal will be produced. The polarity and strength of this signal depends on the direction and amount of relative movement between wiper and potentiometer, *i.e.* the direction and amount of the aircraft's change of attitude. The signal is fed into the amplifier and causes power to be

11. With this type of system there is an inevitable slow loss of aircraft datum in roll, pitch, and yaw, arising from such causes as the tendency of position gyroscopes to wander, the change of electrical balance within the system, and the inability of rate gyroscopes to measure very slow changes of attitude. To counter this weakness, each control axis is provided with a monitoring system which is sensitive to any slow change in the position of the aircraft, the monitor injecting the signal in the appropriate channel to compensate for the loss of aircraft datum on a long-term basis.

12. **Crossfeed.** While all three control channels are fundamentally similar, there are slight differences in detail to meet the requirements of each particular control channel; an example of this is the crossfeed between the rudder and ailerons. The heading, *i.e.* movements in the yawing plane, of a high-speed aircraft is more readily controlled by the ailerons than by the rudder, but the efficiency of the autopilot system in correcting yawing disturbances is greatly improved by controlling the rudder and ailerons simultaneously. This may be achieved by applying the yaw gyroscope signal to both the rudder and aileron channel amplifiers. This arrangement is termed crossfeed and assists in co-ordinating the correcting turns made for small deviations from the desired heading; yawing disturbances are damped by the rudder, but, since the aircraft is steered by the ailerons, deviations from the desired heading are corrected through the ailerons by banking the aircraft.

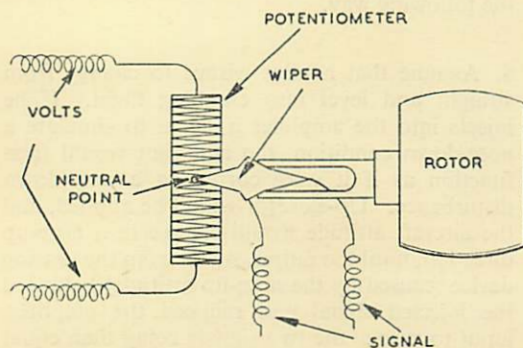

Fig. 2A. Diagrammatic Drawing of a Typical Pick-Off.

13. **Altitude Control.** An altitude-sensitive device is provided on some autopilots. This component

contains an aneroid mechanism which supplies altitude information to the autopilot so that, in the event of a change in altitude, corrective elevator control is applied to maintain the desired altitude.

14. Speed Control. A speed-sensitive device is provided in some systems. This component is sensitive to pitot/static pressure, and interprets this as an I.A.S. which is fed to the autopilot. The autopilot is then made to apply elevator to maintain the airspeed at the value prevailing at the time that the autopilot was engaged.

15. Heading Selections. Certain autopilots enable the pilot to select a specific change of heading. Through a unit coupled to the aircraft compass system, the difference between the actual and desired heading is measured, and the autopilot then operates to turn the aircraft so as to reduce the difference to zero.

16. Powered Controls. The only difference (at present) in the application of the automatic pilot to powered and non-powered control systems is that in non-powered control aircraft the autopilot servomotors work against control surface hinge moments, while in aircraft with

powered controls the autopilot servomotor works against the aircraft feel system.

MARK 10 AUTOPILOT

Note: The operation of Mk. 10 and Mk. 11 Autopilots, which form the basis of this chapter, is described briefly in the subsequent paragraphs. For details regarding the operation of other marks of autopilots the relevant air publication and Pilots' Notes should be consulted.

Controls

17. The autopilot controls available to the pilot may differ between aircraft types, the four possible components being as follows:—

- (a) Control unit.
- (b) Control unit and second pilot's controller.
- (c) Switch unit and pilot's controller.
- (d) Switch unit, pilot's controller, and second pilot's controller.

A remote trim indicator may be an additional fitting with (b) and (c).

Control Unit

18. The control unit (Fig. 3) carries all the controls necessary to operate the autopilot (with the exception of the heading selector). Some installations may have an additional power switch controlling the inverter. The *pull-on* switches, which are a feature of this unit, remain on until the switch is pushed in manually or operation of the autopilot removes the power supply to the electro-magnetic latch incorporated in each switch.

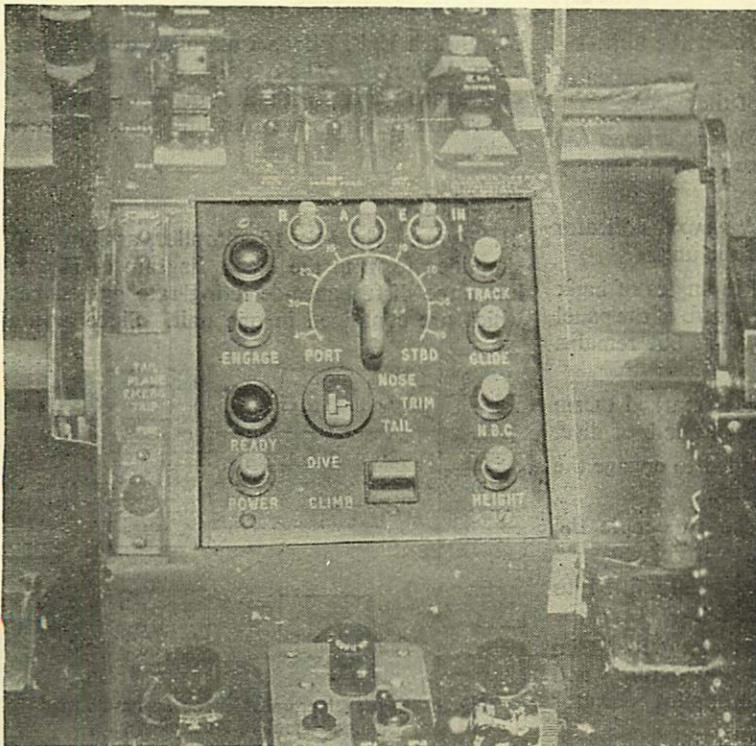

Fig. 3.
Pilot's Controller for the
Mk. 10 Autopilot.

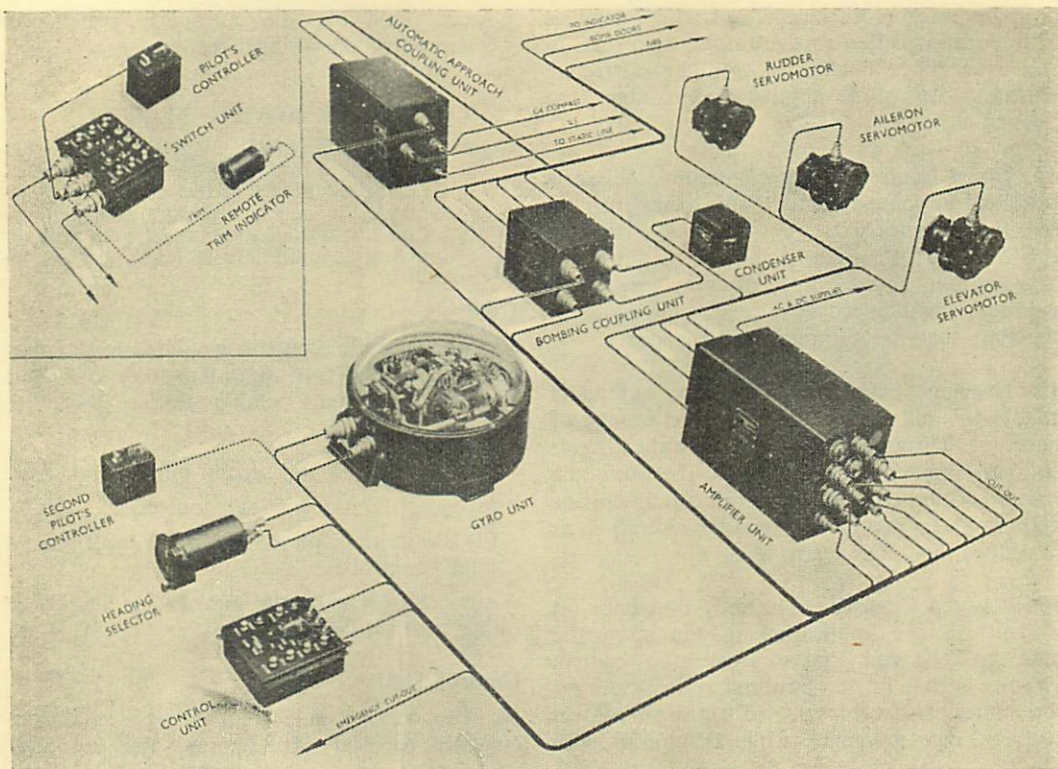

Fig. 4. Schematic Layout of the Mk. 10 Autopilot.

19. The following controls are on the unit:—
- (a) A POWER switch and READY indicator (amber light) is on the left of the panel.
 - (b) Rudder (R), elevator (E), and aileron (A) channel selector switches are fitted at the top of the unit.
 - (c) An ENGAGE switch and READY indicator (green light) is on the left of the unit.
 - (d) A turn control, marked in angles of bank port and starboard, is in the centre of the panel. This control is not self-centring but remains in the selected position.
 - (e) The pitch control, which is marked CLIMB and DIVE, provides two rates of climb or dive.
 - (f) A HEIGHT switch is provided to engage the altitude-sensitive characteristics.
 - (g) The BOMB switch is used to couple the autopilot to the bombing system.
 - (h) TRACK and GLIDE switches are fitted to couple the autopilot to the I.L.S.
 - (j) A trim indicator shows any out-of-trim loads on the elevator servomotor and operates only when the autopilot elevator channel is engaged.

20. Switch Unit, Pilot's Controller, and Remote Trim Indicator. These units carry the same controls as the control unit, but for convenience the various controls are split into three separate units.

Description

21. Gyros. The Mk. 10 autopilot, as shown in simplified form in the block diagram of Fig. 5, has three disturbance-detecting rate gyroscopes which are contained in one unit. Since a rate

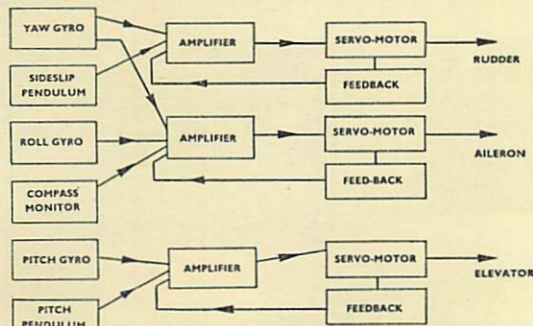

Fig. 5. Block Diagram of Three Servo-Control Channels (Mk. 10 Autopilot).

gyro detects a disturbance in only one plane, the rate gyros are mounted mutually at right angles to detect disturbances in all three axes. The gyros are termed rate gyros because they measure the rate and not the magnitude of a disturbance. They are mounted on a gimbal-supported platform which is free to rotate in both roll and pitch. In level flight the platform is level with, and may be regarded as being fixed to, the aircraft. An electrical pick-off is connected to each rate gyro in such a way that the signal generated by the pick-off is directly proportional to the rate of disturbance. Sudden disturbances of the aircraft are detected and corrected by the stabilizing system. Thus the stabilizing system operates to keep both the platform and the aircraft level in the presence of natural disturbances.

22. Monitors. Very low rates of disturbance or slow changes in attitude cannot be detected by the gyro and therefore, over a period of time, the attitude of the aircraft could change. To prevent this slow change, each servo-control channel is monitored by a device operated by an external reference which is independent of the aircraft's motion. The monitors are devices which are gravity-sensitive in the pitch and roll axes, and magnetically sensitive in the yaw axis. A simple pendulum mounted fore and aft and connected directly to a pick-off is employed to monitor the elevator channel. Any change in pitch is detected by the pendulum, and the pick-off applies a small signal to the elevator channel amplifier to bring the aircraft gradually back to level flight. Another pendulum mounted athwartships detects changes of attitude in the roll axis, and the signal from this pendulum is applied to the rudder-channel amplifier to minimize sideslip.

23. Heading Selector. The heading selector which is a remote indicating compass monitor operated from the main G4B compass system, is set to enable the aircraft to follow a desired heading. Any drift from this heading is detected and a monitoring signal is applied to the aileron-channel amplifier to bank the aircraft and restore it to the required heading.

Use in Flight

24. Climbing or Diving Mechanism. If the platform is deliberately moved in pitch or roll relative to the aircraft, the gyros detect the platform movement in the same way as they would a natural disturbance, and the stabilizing system reacts to move the control surfaces accordingly. For example, if the platform is

tilted forward in pitch relative to the aircraft the pitch gyro detects the movement as a disturbance apparently lowering the nose. The pitch-gyro signal is applied to the elevator servomotor and the elevators move to raise the nose. The rate of pitch of the aircraft is equal and opposite to the rate of pitch of the platform, so that the platform is kept level and the aircraft climbs. The angle of climb is the same as the angle of tilt imparted to the platform. This is illustrated in Fig. 6 where the movements are exaggerated to show the action more clearly.

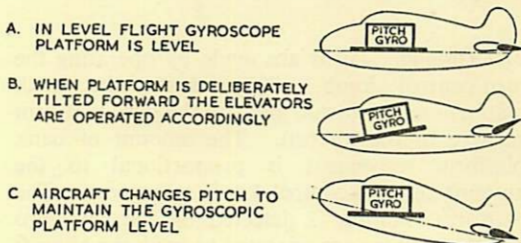

Fig. 6. Manoeuvring an Aircraft in the Pitching Plane.

25. Turning Mechanism. Turns are made by altering the lateral level of the platform. The roll gyro and its associated servo-control system causes the aircraft to take up a desired angle of bank. Since the monitoring signal of the heading selector would otherwise oppose any change of heading, the heading selector is automatically disengaged when a turning manoeuvre is initiated, until the aircraft returns to straight flight on the new heading, at which point the heading selector begins to monitor the autopilot on the new heading. When the bank angle exceeds 5° the crossfeed is also automatically disconnected. Co-ordinated turns are then made through the action of the sideslip pendulum, which is affected both by gravity and centrifugal force in controlling the rudder to minimize sideslip.

26. Diving or Climbing. The gyro platform is moved in pitch and roll relative to the aircraft by a pitch platform motor and a bank platform motor. These motors are remotely controlled by the pitch switch and turn controls on the control unit. To descend, the pitch-control switch is pressed forward, causing the pitch motor to run and tilt the gyro platform to an angle relative to the aircraft. The pitch gyro detects the rotating movement of the platform and moves the elevators accordingly, so that the aircraft alters its pitch attitude to maintain the level of the gyro platform. When the desired rate of descent

RESTRICTED

A.P. 129, VOL. 1, PART 1, SECT. 6, CHAP. 4

is attained the switch is released. The pitch platform motor then stops running and the aircraft maintains the same steady descent under the control of the autopilot. It should be noted that the stabilizing system still operates normally, and the natural disturbances are corrected. To return to level flight, the pitch-control switch is pressed back and the reverse sequence of operations takes place. When the aircraft is flying level, release of the pitch-control switch, which is spring-loaded to the off position, stops the platform motor and the autopilot once more maintains level flight.

27. **Turning.** Turns are made by operating the turn-control knob. This causes the bank platform motor to run and roll the gyro platform relative to the aircraft. The amount of bank platform movement is proportional to the amount of turn-control knob movement. The platform rotation is detected by the roll gyro and the ailerons are operated to bank the aircraft in the turn; this keeps the platform level in space. The turn is maintained until the knob is returned to the central position when the motor begins to run again, but in the reverse direction until the aircraft is flying straight and level.

Automatically Controlled Manœuvres

28. The pitch platform and bank platform motors can also be controlled by other electro-mechanical systems such as I.L.S. or a bombing system. Selection of the appropriate system is made by the pilot through switches on the autopilot controls, and the circuits are designed to ensure that the platform motors are controlled by only the selected system at any particular time.

29. When the I.L.S. is coupled to the Mk. 10 autopilot, the localizer signals are applied to the bank platform motor to control the heading of the aircraft, and the glide path signals are applied to the pitch platform motor to control the descent of the aircraft down to the runway. The combined I.L.S. and autopilot Mk. 10 can fly the aircraft in a completely blind approach down to the runway, at which point the pilot can disengage the autopilot and land the aircraft himself.

30. Signals from a bombing system may be fed into the autopilot and allowances made, by suitable signals, to counter the effects on bombing accuracy of opening the bomb doors.

MARK 11 AUTOPILOT

Basic Operation

31. The basic operation of the Mk. 11 autopilot (Fig. 7) depends initially on five variable factors:—

(a) Aircraft pitch and roll attitude information obtained continuously from the artificial horizon unit.

(b) Heading information obtained from the gyro-magnetic compass gyro unit Type C (when the aircraft is flown on a set course by the autopilot).

(c) Selected rates of climb or dive, or level flight, as set on the pitch control of the pilot's controller.

(d) The selected bank angle (including zero bank) set on the turn control of the pilot's controller.

(e) Altitude information obtained from the altitude control. This maintains the aircraft at the desired flight altitude or, in association with the pilot's controller, provides changes in the altitude information for controlled rates of climb or dive.

32. All this information is produced in the form of signals which are combined and amplified in the separate elevator, rudder, and aileron channels in the amplifier unit. The resultant control signals are fed into the hydraulic control where they operate the three electro-magnetic clutch and oil valve assemblies which control the hydraulic servomotors connected to the aircraft control surfaces.

33. The servomotors are connected directly to the flying controls and to the aircraft structure by hydraulic locking jacks. Engagement and disengagement of autopilot aircraft control is made electrically by means of the ON/OFF switch on the pilot's controller.

34. The two gyros used in this autopilot are those in the artificial horizon and the Mk. 4B gyro-magnetic compass. Thus the flight instruments serve a dual purpose, *i.e.* the artificial horizon has a pick-off that produces signals to provide corrective control in roll and pitch, and the gyro-magnetic compass has a pick-off that produces signals to maintain direction.

Note: The artificial horizon fast-erection button must not be used with the autopilot engaged.

RESTRICTED

RESTRICTED

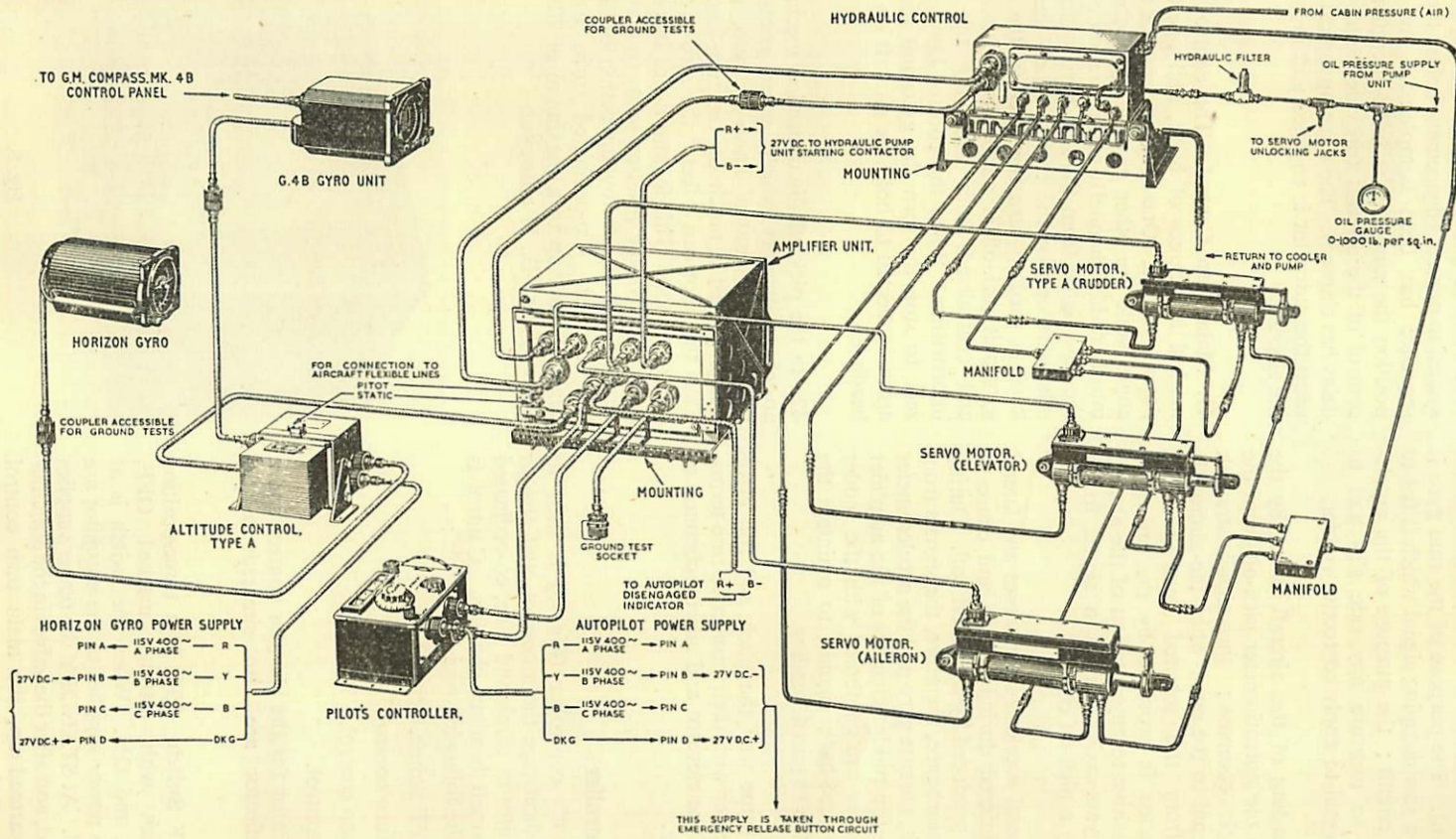

Fig. 7. Layout of the Mk. II Autopilot.

(ALL4, May '55)

AUTOPILOTS AND AUTOSTABILIZERS

RESTRICTED

A.P. 129, VOL. 1, PART 1, SECT. 6, CHAP. 4

35. In addition, this autopilot has a rate gyro and lateral accelerometer incorporated in the amplifier unit. The purpose of the rate gyro is to produce a yaw damping signal which is fed to the rudder circuit; the purpose of the accelerometer is to measure any side slip and to provide a signal to apply corrective rudder.

36. The heading of the aircraft is set by the signal from the potentiometer pick-off from the gyro-magnetic compass; the signal strength is proportional to the error when the aircraft is disturbed from the selected heading. The damping factor is provided by the rate gyro which is sensitive to any rotation of the aircraft about the yaw axis, causing a signal to be produced by a pick-off coil.

37. The lateral accelerometer senses any lateral force encountered during a turn and causes a signal to be produced by a pick-off coil. During a yawing disturbance, therefore, the signals from the gyro unit, the rate gyro and the accelerometer are fed into the rudder channel of the amplifier unit where they are combined with the rudder clutch, and feed-back signals, to maintain the aircraft on the required heading.

38. In the same way the pitch and roll error signals, together with their respective rate terms, are fed into the elevator and aileron channels of the amplifier.

Pilot's Controller

39. The pilot's controller (Fig. 8) is used to engage and disengage the autopilot, and also to initiate set rates of climb and dive, co-ordinated turns, and small heading changes. Control is effected by the following rotary controls:—

- (a) ON/OFF switch.
- (b) Main turn control.
- (c) Fine turn control.
- (d) Pitch control.

A trim indicator for the elevator control and a warning indicator are also situated on the controller.

40. **ON/OFF Switch.** This is a three-position rotary switch with settings marked OFF, STANDBY, and ON. When the switch is at OFF, all the power supplies to the autopilot are disconnected. At STANDBY the power supplies are connected, and after the valves in the amplifier unit have warmed up, the main turn control knob and the pitch control knob are driven into

alignment with the attitude of the aircraft. A time delay of one minute is incorporated in the system to prevent engagement before the standby sequence has been completed. At the ON position the autopilot is fully operative and in control of the aircraft (provided that the time delay has elapsed). The warning indicator shows when the autopilot is engaged and in control of the aircraft.

41. **Main Turn Control.** The control knob is marked in degrees of bank, and operates two potentiometers. One of these demands the bank angle while the other gives a signal that is fed into the rudder channel to neutralize approximately the yaw signal from the rate-gyro which would otherwise oppose the turn. When the control knob is used to turn the aircraft, the compass gyro-unit pick-off is mechanically disconnected and centralized, thus removing the heading information. When the control knob is set to zero to stop the turn the gyro-unit pick-off is again connected to hold the aircraft on the new heading.

42. In the pick-off disconnection mechanism is an electro-magnet which, when energized by returning the control knob to zero, places a wedge against a notch on the turn-knob shaft. Thus the pilot can "feel" the zero position of the turn knob. This feature is not incorporated in the STANDBY position so as to avoid interference with the follow-up action of the main turn control. Co-ordinated turns using any angle of bank up to a maximum of 70° can be made by the Mk. 11 autopilot.

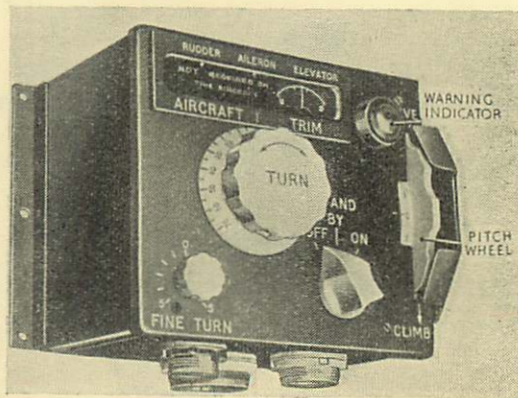

Fig. 8.

Pilot's Controller for the Mk. 11 Autopilot.

RESTRICTED

AUTOPILOTS AND AUTOSTABILIZERS

43. **Fine Turn Control.** With the autopilot fully engaged and supplying heading and altitude information, small changes in heading, using the rudder only, may be carried out by this control, which is a single potentiometer in the rudder amplifier circuit. To alter heading by not more than 3° to 4° the fine turn control is moved in the required direction by the appropriate amount. The fine turn control must be left at the new position, since if it were returned manually to zero the aircraft would resume its original heading. To provide the full range of fine heading adjustment after any turn made through the main turn control, the fine turn control is returned automatically to the central position every time the main turn control is used.

44. **Pitch Control.** The pitch control wheel is marked with an arbitrary scale of climb and dive markings, and operates a potentiometer which enables alterations in the flight path of the aircraft to be made up to a maximum rate of climb or dive of 2,500 ft./min. Movement of the pitch control wheel feeds the selected rate of climb or dive into the altitude control, which then controls the rate of change of altitude. A mechanism similar to that fitted to the main turn control provides "feel" of the level flight position.

Trim Indicator

45. The trim indicator shows the steady force applied by the elevator servomotor to correct any aircraft out-of-trim forces. The pilot is thus given a continuous indication of the aircraft trim to enable him to retrim the aircraft manually before disengaging the autopilot.

Warning Indicator

46. The warning indicator is in the form of a flag which shows when the pilot's controller ON/OFF switch is at ON and the autopilot is engaged. If the valves in the hydraulic control reach the end of their travel, however, or certain other defects occur, the autopilot is disengaged and the indicator returns to OFF. In such an event the autopilot returns to the standby conditions although the ON/OFF switch may still be at ON.

Disengagement

47. Manual control can be regained at any time by moving the ON/OFF switch to STANDBY. For long periods of disengagement, or when the

autopilot is no longer required, it is advisable to return the switch to OFF, since the servo locking jacks secure the servomotor cylinders to the airframe when the switch is at STANDBY. The autopilot can be re-engaged at any time by reselecting ON, but allowance must be made for the standby sequence when re-engaging from OFF. In an emergency, manual control can be regained by operating the emergency release button on the control column; if the pilot wishes to re-engage the autopilot after the emergency button has been pressed, he must press a reset button, normally adjacent to the pilot's controller, before switching to STANDBY, allowing for the standby sequence, and then to ON.

Safety Features

48. Turning the ON/OFF switch to OFF or pressing the emergency release button breaks the D.C. supply to the autopilot and so isolates it. A system of electrical interlocking relays with trip-out switches is provided to :-

(a) Prevent engagement of the autopilot in the presence of serious malfunction or misalignment, or before the standby sequence has been completed.

(b) Ensure automatic disengagement of the autopilot in the event of a failure causing a dangerous "hard over" signal.

49. The trim indicator on the pilot's controller is also a safety feature, since by continuously showing the amount of effort applied by the autopilot to correct out-of-trim elevator forces, it enables the pilot to assess the amount and direction of trimming required to retrim the aircraft to a condition in which it can safely be handled manually, without excessive stick forces, before returning to manual control.

AUTOSTABILIZER, MARK 1

Introduction

50. The autostabilizer is fitted to some aircraft which have snaking or Dutch rolling characteristics that affect their operational usefulness. The Mk. 1 autostabilizer detects any yawing oscillations and suppresses these by actuating the rudder trimming tab. In this way continuous snaking and Dutch rolling are overcome.

RESTRICTED

A.P. 129, VOL. 1, PART 1, SECT. 6, CHAP. 4

51. The autostabilizer consists of three main units : a gyro unit (Fig. 9), a control box, and a servomotor. These are connected to the 115v., 400 c/s, 3-phase A.C. supply and to the 27-volt battery supply. The three units are energized when the main aircraft supply is switched on, and remain energized throughout the flight, but the pilot has an ON/OFF switch in the cockpit by which the gyro signal is controlled, thus rendering the system operative at will.

52. To prevent damage to the servomotor while the aircraft is being manœuvred on the ground with no air loads on the rudder trimming tab, a second switch is wired in series with the cockpit switch, and this is switched off when the under-carriage is selected down.

53. For ground testing, a special switch spring-loaded to OFF and located near the control box must be held down for tests.

Principles of Operation

54. **Detection of Yaw.** With all units connected and energized, and with the signal switch in the cockpit ON, any yawing movement greater than 3° per minute is detected by the rate gyro which generates a D.C. voltage signal proportional to the rate of yaw. The magnitude of the gyro signal is quite small, so the signal level is amplified to drive a 10W electric motor in the servomotor unit. The circuit supplies a final intermittent current output to the servomotor. The sensitivity of the autostabilizer is very high, a rate of turn of little more than 3° per minute being sufficient to actuate the servomotor.

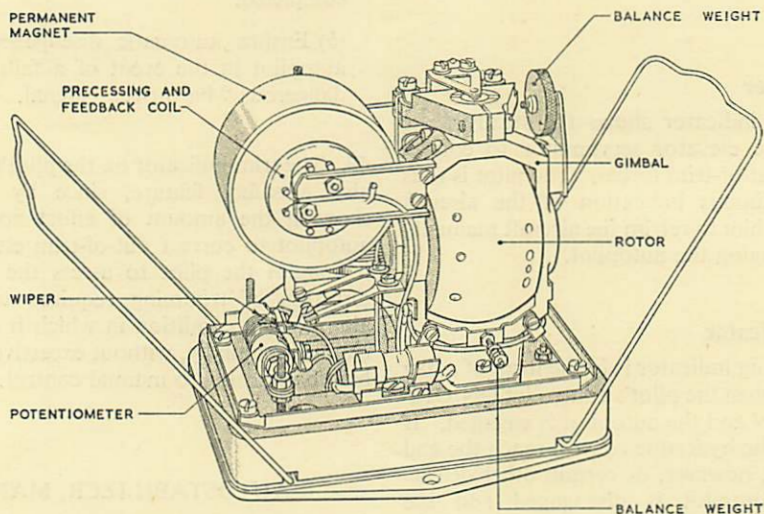

Fig. 9. Mk. I Autostabilizer—Gyro Unit.

RESTRICTED

(A.L.4, May '55)

Installation

55. Fig. 10 shows the installation of the servo unit on the aircraft. It is supported at one end by the external lead screw nut and at the other end is mounted in a support for the actuating shaft bearing. The unit is free to move along its longitudinal axis but is prevented from turning about this axis by a guide pin on the servomotor casing; the guide pin engages with a guide plate bolted to the bearing plate. The sprocket connects the external lead screw to the pilot's rudder trimming control mechanism, while the actuating shaft is connected to the rudder trimming tab. An earth connection is provided on the casing for connection to the aircraft structure.

56. When the autostabilizer is in operation the movement of the rudder trimming tab is controlled by the mechanism in the servo unit. For manual trimming, however, the tab is controlled by the pilot's rudder trim control in the normal way. This turns the sprocket and nut and actuating rod together in the desired direction.

Operation in Flight

57. The autostabilizer is designed to suppress instantly any tendency of the aircraft to oscillate in yaw or to Dutch roll by increasing the directional damping. The equipment functions in any condition of flight, the only control being the ON/OFF switch. The pilot experiences a slight resistance to his demand to alter his rate of yaw (on the rudder pedals), and in general he may feel fairly rapid, low-amplitude movements of his rudder pedals due to the action of the autostabilizer, especially when flying in turbulent air. The rudder pedal movements should not be restrained.

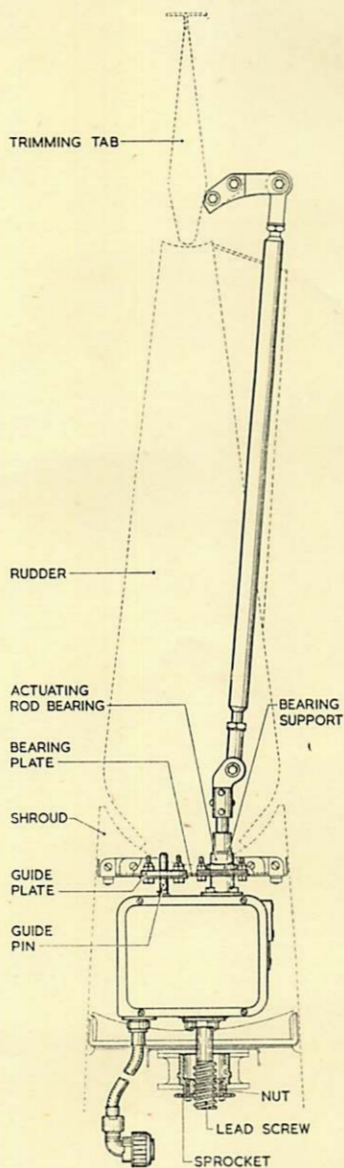

Fig. 10.

Mk. I Autostabilizer—Installation of Servomotor in the Fin.

This file was downloaded
from the RTFM Library.

Link: www.scottbouch.com/rtfm

Please see site for usage terms,
and more aircraft documents.

