

RESTRICTED

PART 2 : SECTION 1

CHAPTER 3

WEIGHT AND BALANCE

Introduction

1. Although the principles explained in this chapter are applicable to all aircraft, it is only for transport aircraft that the A.U.W. and C.G. have to be calculated before each flight. Aircraft employed on specific roles, *e.g.* bombers, are loaded in accordance with Typical Service Load Tables which are compiled by the makers and which, provided that they are adhered to, ensure that the aircraft's weight and C.G. are kept within the limits. Although it is only the transport aircraft captain who is directly concerned with the calculation of weight and balance, all captains are responsible for the safety of their aircraft and it is therefore important that they all fully understand the factors affecting aircraft loading.

Weight

2. Definition of Weight Terms. The weight terms used in the R.A.F. are defined as follows :—

(a) *Tare Weight.* The weight of an aircraft equipped to a minimum scale, *i.e.* with all equipment, the weight of which is listed in column 10 of the Appendix "A" (see para. 3), plus the weight of coolant in the engines, radiators, and associated systems ; residual fuel and oil in tanks, engines, and associated systems ; residual fluid in the de-icing systems ; and hydraulic fluids.

(b) *Operational Load.* The weight of equipment necessarily carried by an aircraft for a particular role. This equipment is that specified in columns 7 and 9 of the Appendix "A", less the items the weights of which are shown in column 10.

(c) *Basic Weight.* The tare weight of an aircraft plus the specified operational load.

(d) *Disposable Load.* The weight of crew, consumable load, and pay load. The consumable load consists of fuel, oil, de-icing fluid, drinking water, and armament missiles.

(e) *Pay Load.* The weight of passengers and/or cargo.

(f) *All-Up Weight.* The total weight of an aircraft in operating condition.

(g) *Normal Maximum All-Up Weight.* The maximum A.U.W. at which an aircraft is permitted to fly within normal design restrictions.

(h) *Overload Weight.* The maximum A.U.W. at which an aircraft is permitted to fly subject to ultimate flying restrictions.

(j) *Take-Off Weight.* The A.U.W. of an aircraft at the moment of take-off.

(k) *Maximum Take-Off Weight.* The maximum A.U.W., due to design or operational limitations, at which an aircraft is permitted to take off.

(l) *Landing Weight.* The A.U.W. of an aircraft at the moment of landing.

(m) *Maximum Landing Weight.* The maximum A.U.W., due to design or operational limitations, at which an aircraft is permitted to land.

The normal maximum, overload, maximum take-off, and maximum landing weights of any aircraft are given in Pilot's Notes and Volume 1 of the appropriate airframe handbook, while for transport aircraft these data and the basic weight are also given in the aircraft's Weight and Balance Data Book.

Appendix "A" (Manual of Aircraft Equipment)

3. The Appendix "A" mentioned in the definitions in para. 2 is an appendix to the aircraft specifications. It is laid out in columns, states the scale of fixed and removable equipment required for each of the operational roles of the aircraft, and is used for provisioning and checking purposes. The columns used for provisioning and checking are :—

(a) *Column 7.* This shows the equipment, both fixed and removable, which is transferred with the complete aircraft, and is, within the R.A.F., the easiest column with which to check an aircraft, as the quantities specified include everything which ought to be installed in an aircraft when it is flown from one unit to another ; subject, of course, to any overriding operational conditions.

RESTRICTED

A.P. 129, VOL. 2, PART 2, SECT. 1, CHAP. 3

(b) *Column 9.* This shows the quantities of the items drawn from the operational unit's stocks and installed by that unit. These items are issued to an Air Ministry scale based on operational requirements and they are always easily removed from the aircraft.

(c) *Column 10.* This records the weights of all items of equipment permanently fixed in the aircraft. It will be apparent that some weights shown in Column 10 are for equipment readily detachable, but for policy reasons this equipment must never leave the aircraft except for repairs and is therefore classed as fixed. All weights recorded in Column 10 are included in the aircraft's tare weight.

Aircraft Weight Limitations

4. A limitation is imposed on the A.U.W. at which any aircraft is permitted to operate. This limitation depends on the strength of the structural components of the aircraft and the operational requirements that the aircraft is designed to meet. If it is exceeded, the safety of the aircraft may be jeopardized and its operational efficiency impaired. Before each flight a captain must therefore check that the tare weight of his aircraft—plus its removable equipment, fuel and lubricants, crew, and any load it may be required to carry—does not exceed the normal maximum A.U.W. Aircraft can be operated, subject to certain flying restrictions, at an A.U.W. in excess of the normal maximum (overload weight), but permission for such operation is granted only in rare circumstances.

Effect on Performance of Overloading

5. If the maximum A.U.W. of an aircraft is exceeded, its performance will be affected in the following ways :—

(a) The safety factor will be reduced, and the breaking point of some structural components may be reached as a result of *g* imposed during normal manoeuvring or in conditions of turbulence.

(b) The stalling speed will be higher. This will in turn entail longer take-off and landing runs.

(c) The rate of climb will be lower.

(d) The ceiling will be lower.

(e) The range and endurance will be decreased.

(f) The performance while on asymmetric power will be adversely affected.

Balance

6. The importance of ensuring that the normal maximum A.U.W. of an aircraft is not exceeded has already been stressed ; but of even greater importance is the distribution of that weight, *i.e.* the balance of the aircraft.

7. **Definitions.** To understand what is meant by "balance" as applied to aircraft it is necessary to define the following terms :—

(a) *Centre of Pressure (C.P.).* The centre of pressure is the point through which the resultant lifting force of a wing acts.

(b) *Centre of Gravity (C.G.).* The C.G. is that point in a body through which the resultant of the weights of all its parts passes. A body suspended from this point will be in a state of equilibrium.

(c) *Arm.* An arm is the distance, measured along the longitudinal axis of an aircraft, between some predetermined point (usually the nose) and the C.G. either of the aircraft or of any item of aircraft load or equipment.

(d) *Moment.* The moment of a force is its turning effect about a point. Its size, which is measured in pounds feet (lb. ft.), is the product of the force (in lb.) and the perpendicular distance (in ft.) from the line of action of the force to the point. Clockwise moments are positive, and anti-clockwise moments are negative.

8. **Aircraft Design.** It is not possible to design an aircraft in which the four forces—lift, weight, thrust, and drag—are always in equilibrium during straight flight, as the positions of the C.P. and the drag line vary with changes of the angle of attack, while the position of the C.G. depends on the load distribution. The designer has therefore to provide a force to counteract unwanted turning moments that may be set up by these four forces. This is the function of the tailplane, which also provides longitudinal stability for the aircraft. The design of the tailplane, its elevator, and its trimmers, is such that it can offset any turning moment set up by the movement of the positions of the C.P. or drag line. Also it is capable of offsetting any unbalance or unstable tendencies caused by the movements of the C.G., provided that such movement is confined to certain limits. These limits, which are specified by the makers, are known as the C.G. limits, and they can be ascertained from Volume 1 of the airframe handbook or the aircraft's Weight and Balance Data Book.

RESTRICTED

9. **Effects of Unbalanced Loading.** Incorrect loading has the following effects on performance :—

(a) C.G. too far forward (nose heavy) :—

(i) Necessitates a larger elevator movement for the round-out. This may be so marked as to require a higher approach speed.

(ii) Possible over-stressing of the main undercarriage wheels when the aircraft is landed. This may result in a burst tyre or collapsed undercarriage.

(b) C.G. too far aft (tail heavy) :—

(i) The aircraft will become less stable and may become definitely unstable. The condition may lead to loss of control.

(ii) Increases pilot strain, particularly in instrument flying.

(iii) In some aircraft the increased load on the tailplane may cause flutter.

Effect of Fuel Load on C.G. Position

10. In high-performance heavy aircraft, large quantities of fuel are carried in the fuselage and wings. As this fuel is used, the position of the C.G. may change.

11. The longitudinal movement of the C.G. will be minimized if fuel is used by selecting the tanks in a sequence recommended in Pilot's Notes. This selection may in some cases be automatic.

12. Lateral movement of the C.G. will result if wing tanks are used unevenly. The amount of lateral displacement will depend on the distance of the tank(s) from the longitudinal axis, and the weight difference in comparison with the other wing. The inertia effect of very uneven weight in the wings will lead to changes in the oscillatory stability of the aircraft.

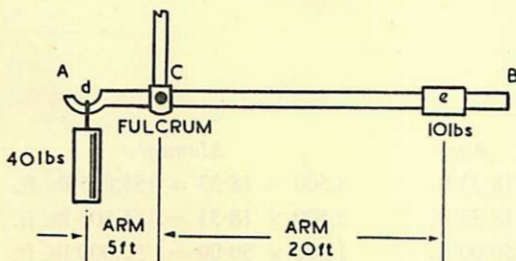

Fig. 1. Principle of Arms and Moments

AB is a lever balanced about its fulcrum C. If a 40-lb. weight is suspended from a point d, 5 ft. from C, and a 10-lb. weight from point e, 20 ft. on the other side of C, the lever will remain balanced. This is because the positive moment, 10×20 lb. ft., tending to rotate the lever in a clockwise direction about point C is equalled by the negative moment, 40×5 lb. ft., tending to rotate the lever in an anti-clockwise direction about point C.

13. If less than full fuel load is to be carried, the fuel will have to be distributed in the tanks so that the C.G. is kept as near as possible to its desired position.

Determination of the C.G.

14. In addition to checking that his aircraft's normal maximum A.U.W. is not exceeded, a pilot must ensure that it is loaded so that its C.G. lies within the limits and will not move outside these either through the disposal or the movement of the load during flight. If he is to be capable of carrying out this responsibility, a pilot must be conversant with the method used for calculating the C.G. This is explained below.

15. **The Principle of Arms and Moments.** Because the turning effect of any weight about a point of balance is directly proportional to its distance from that point, the moment of a large weight near the point of balance can be equalled by that of a small weight at a proportionately greater distance from the fulcrum. This is derived from the formula: $\text{Weight} \times \text{Arm} = \text{Moment}$. Fig. 1 makes this clear.

16. **Practical Application of the Principle.** From the formula $\text{Weight} \times \text{Arm} = \text{Moment}$, it follows that $\text{Arm} = \frac{\text{Moment}}{\text{Weight}}$. In practice this latter formula is used to determine the position of the C.G. of any aircraft. This position is calculated from the weights and arms of the various components of the aircraft, its fuel load, crew, passengers, and any other loads or equipment. By multiplying these weights by their respective arms, their moments about the selected point are found. The sum of the moments divided by the sum of the weights gives a resultant arm which, when measured from the reference point about which the moments of the individual weights were calculated, locates the C.G. of the loaded aircraft. As long as the position of the C.G. is within certain limits, the aircraft is safe to fly. However, as all aircraft have an ideal C.G. position, *i.e.* one which allows the aircraft to give its best flight performance, an endeavour should be made to distribute the payload so that this position is obtained. Examples 1 to 3 illustrate the practical uses of the procedure outlined above.

RESTRICTED

A.P. 129, VOL. 2, PART 2, SECT. 1, CHAP. 3

Example 1—Calculation of C.G. (Aircraft in Basic Condition)

17. Raise the aircraft to its flying attitude and select some arbitrary position, *i.e.* reference line, on the longitudinal axis of the aircraft (*e.g.* at the nose), and measure the distance, parallel to the aircraft datum line, to points vertically above the centres of the undercarriage wheels. Next, with the aircraft still in the flying attitude, find the weight supported by each undercarriage member. These weights multiplied by their arms give the moments; the sum of these moments divided by the total weight results in the average arm. A mathematical illustration is given below.

The C.G. therefore lies somewhere in a line passing through the longitudinal axis of the aircraft at a point 20.1 ft. from the nose.

Example 2—Calculation of C.G. (Loaded Aircraft)

18. Ascertain the weight and C.G. of the aircraft in its basic condition from the aircraft's Weight and Balance Data Book, and from these calculate the aircraft's moment. To this weight and moment add those of the aircraft's crew and their baggage, items of the consumable load, and items of the pay load. The total of the moments divided by the total weight will give a distance

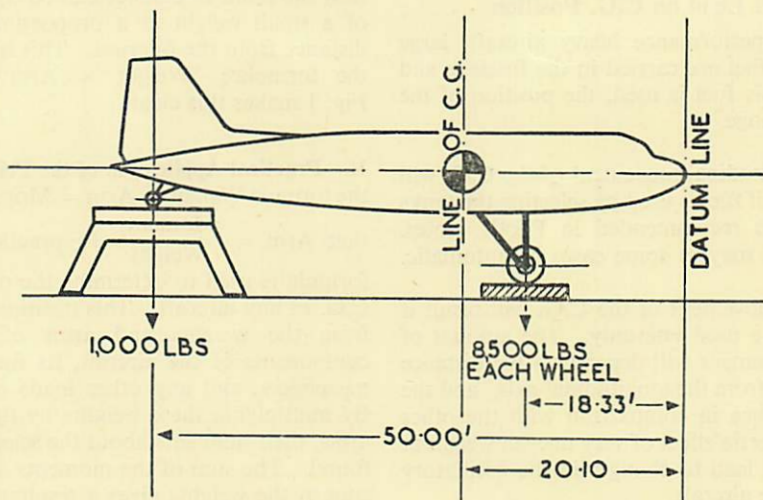

	<i>Weight</i>	<i>Arm</i>	<i>Moment</i>
Weight on port wheel ...	8,500 lb.	18.33 ft.	8,500 × 18.33 = 155,805 lb. ft.
Weight on starboard wheel ...	8,500 lb.	18.33 ft.	8,500 × 18.33 = 155,805 lb. ft.
Weight on tail wheel ...	1,000 lb.	50.00 ft.	1,000 × 50.00 = 50,000 lb. ft.
	<u>18,000</u>		<u>361,610</u>

$$\text{Average Arm} = \frac{\text{Total Moments}}{\text{Total Weight}} = \frac{361,610}{18,000} = 20.1 \text{ ft.}$$

RESTRICTED

WEIGHT AND BALANCE

which, when measured from the reference line, will locate the C.G. of the aircraft in its loaded condition. If this C.G. is not within the limits, the load, or part of it, will have to be moved to a more appropriate position, and the C.G. recalculated. The foregoing is made clear by the following calculation and Fig. 3 :—

The C.G. limits for this hypothetical aircraft are from 19.0 ft. to 21.0 ft. aft of the reference line. Thus it can be seen that the C.G. of the aircraft when loaded as shown in Fig. 3 is outside the limits, and the load must therefore be readjusted to make the aircraft safe to fly.

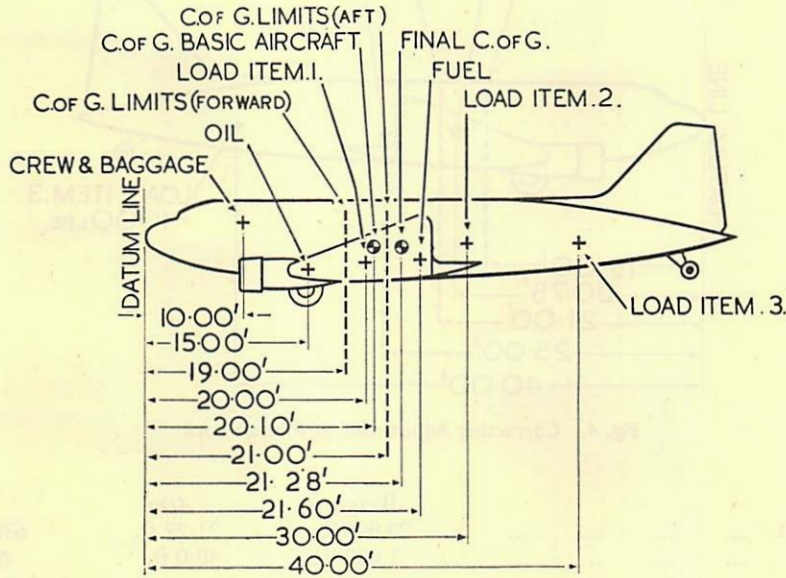

Fig. 3. Incorrectly Loaded Aircraft

	<i>Weight</i>	<i>Arm</i>	<i>Moment</i>
Basic aircraft	18,000 lb.	20.1 ft.	18,000 × 20.1 = 361,800 lb. ft.
Crew and baggage	1,000 lb.	10.0 ft.	1,000 × 10.0 = 10,000 lb. ft.
Oil (40 imp. galls.)	360 lb.	15.0 ft.	360 × 15.0 = 5,400 lb. ft.
Fuel (800 imp. galls.)	5,760 lb.	21.6 ft.	5,760 × 21.6 = 124,416 lb. ft.
Load item 1	2,000 lb.	20.0 ft.	2,000 × 20.0 = 40,000 lb. ft.
Load item 2	1,800 lb.	30.0 ft.	1,800 × 30.0 = 54,000 lb. ft.
Load item 3	1,076 lb.	40.0 ft.	1,076 × 40.0 = 43,040 lb. ft.
	<u>29,996</u>		<u>638,656</u>

$$\text{Arm} = \frac{\text{Total Moment}}{\text{Total Weight}} = \frac{638,656}{29,996} = 21.29 \text{ ft.}$$

RESTRICTED

A.P. 129, VOL. 2, PART 2, SECT. 1, CHAP. 3

Example 3—Correction of the C.G. Position

19. To correct the position of the C.G., part of the load must be moved to a more appropriate position in the aircraft. For example, move 1,000 lb. of load item 3 (Fig. 3) from its position at 40.0 ft. to a position at 25.0 ft. (Fig. 4). The new C.G. can then be calculated as follows:—

to make last minute alterations either to the load or its distribution.

Load Security

21. Once an aircraft has been loaded according to the requirements explained above, the load must remain in the same position or the C.G.

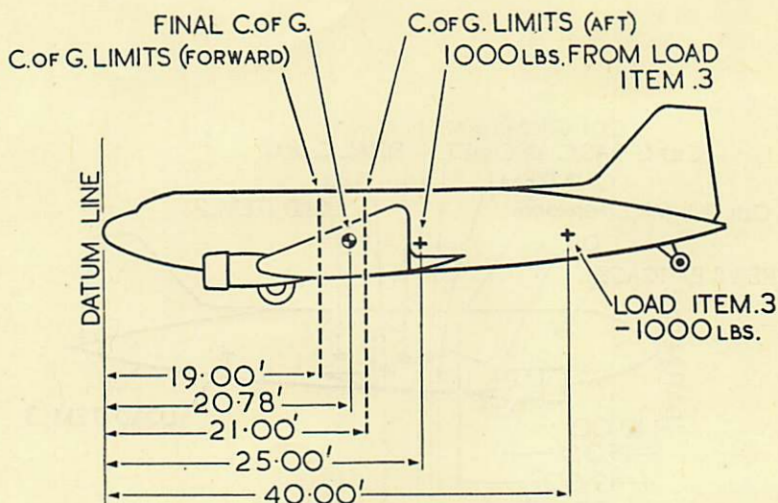

Fig. 4. Correcting Adjustment to Aircraft Load

	<i>Weight</i>	<i>Arm</i>	<i>Moment</i>
Loaded aircraft	29,996 lb.	21.29 ft.	638,656 lb. ft.
Deduct	1,000 lb.	40.0 ft.	40,000 lb. ft.
	<hr style="width: 50%; margin: 0 auto;"/>		<hr style="width: 50%; margin: 0 auto;"/>
Add	1,000 lb.	25.0 ft.	25,000 lb. ft.
	<hr style="width: 50%; margin: 0 auto;"/>		<hr style="width: 50%; margin: 0 auto;"/>
	29,996		623,656

$$\text{New Arm} = \frac{623,656}{29,996} = 20.79 \text{ ft.}$$

The C.G. is now 20.79 ft. from the reference line, and is thus within the limits, so the aircraft is safe to fly.

Aircraft Weight and Balance Clearance Form

20. The specimen Aircraft Weight and Balance Clearance Form (Fig. 5) illustrates the procedure used in Transport Command for calculating the pay load that can be carried by an aircraft on a specific flight, and the C.G. of the loaded aircraft. The arrows on the diagram indicate how the final C.G. is calculated, if it is necessary

may become displaced. This security of the load can only be assured by taking into consideration the following factors:—

- (a) The acceleration and deceleration forces affecting the load during flight.
- (b) The strength of the lashing material.
- (c) The position and strength of the lashing points in the aircraft.
- (d) The strength of the aircraft floor. (A maximum floor loading is specified for each type of aircraft; should any item of load exceed this maximum owing to its density, it must be placed on spreaders.)

AIRCRAFT WEIGHT & BALANCE CLEARANCE

AIRCRAFT TYPE DAKOTA MK. VI No. KN675 UNIT 215 SQUADRON
FLIGHT No. 332 DATE 10/7/48 FROM FAYID TO EIADEM

PART 1 PAYLOAD CALCULATION (TO BE COMPLETED BY CAPTAIN)

	WEIGHT			ARM			MOMENT							
	I	9	8	5	2	I	0	0	4	I	6	9	5	5
BASIC AIRCRAFT (FROM LOADING DATA)														
ADD CREW		7	0	0	I	0	0	0				7	0	0
CREW BAGGAGE		I	0	0	I	0	0	0				I	0	0
OIL 48 US/IMP GALS.		4	3	2	I	5	0	0				6	4	8
WINDSCREEN DE-ICING FLUID 5.4 US/IMP GALS.			4	3		9	2	2					3	9
WING DE-ICING FLUID US/IMP GALS.														
PROP DE-ICING FLUID 3.5 US/IMP GALS.				3	9		6	7	5				2	6
CARB. DE-ICING FLUID 8.3 US/IMP GALS.			6	6	I	0	5	8					6	9
DRINKING WATER 5 US/IMP GALS.		5	0	I	4	I	9						7	I
TOILET WATER 3 US/IMP GALS.		3	0	4	5	8	3						I	3
AIRCRAFT LESS FUEL AND PAYLOAD	2	I	3	I	5							4	3	4

PERMISSIBLE ALL UP WEIGHT _____
 DEDUCT AIRCRAFT LESS FUEL AND PAYLOAD (FROM ABOVE) _____
 AVAILABLE FOR FUEL AND PAYLOAD _____
 DEDUCT FUEL IN TANKS AT TAKE OFF 400 US/IMP GALS.
 FUEL IN TANKS ON LANDING 110 US/IMP GALS.
 AVAILABLE FOR PAYLOAD (USE LESSER FIGURE) _____
 REQUIRED C.G. POSITION 21.00 FT.

TAKE OFF	LANDING
2 8 0 0 0	2 7 0 0 0
2 1 3 1 5	2 1 3 1 5
6 6 8 5	5 6 8 5
2 8 8 0	
	7 9 2
3 8 0 5	4 8 9 3

PART 2 LOAD DISTRIBUTION (TO BE COMPLETED BY TRAFFIC OFFICER)

COMP	PASSENGERS		BAGGAGE		FREIGHT		MAIL		TOTAL WEIGHT	ARM	MOMENT												
	No.	WEIGHT	No.	WEIGHT	No.	WEIGHT	No.	WEIGHT															
	AIRCRAFT LESS FUEL AND PAYLOAD								2	I	3	I	5			4	3	4	8	7	7		
A																							
B							3	70		70	I	0	0	0						7	0	0	
C																							
D	7	1100	6	190			8	370	I	2	9	0	I	9	0					2	4	5	
E	6	900	8	240	2	160			I	3	0	0	2	7	0	0				3	5	I	
F	3	470	5	180	I	84	0	-370	I	I	0	4	3	4	0	0				3	7	5	
C																							
H																							
J																							
K																							
TOTAL	I6	2470	I9	610	3	244	II	440															
	FUEL IN TANKS AT TAKE OFF 400 US/IMP GALS.								2	8	8	0	2	I	0	0					6	0	4
	AIRCRAFT TAKE OFF CONDITION								2	7	9	5	9	2	I	2	I			5	9	3	
	ESTIMATED FUEL IN TANKS ON LANDING 110 US/IMP GALS.								7	9	2	2	I	0	0					I	6	6	
	AIRCRAFT LANDING CONDITION								2	5	8	7	I	2	I	2	3			5	4	9	
	ADDITIONS								3	7	0	I	9	0	0					7	0	3	
	DELETIONS								3	7	0	3	4	0	0					I	2	5	
	CORRECTED TAKE OFF CONDITION								2	7	9	5	9	2	I	0	2			5	8	7	
	CORRECTED LANDING CONDITION								2	5	8	7	I	2	I	0	2			5	4	3	

C.G. LIMITS:- FORWARD 19.96 FT. AFT 21.92 FT.

PART 3 CERTIFICATE

CERTIFIED THAT THE PAYLOAD IS DISTRIBUTED AS SHOWN IN PART 2 AND IS SAFELY SECURED.
 _____ TRAFFIC OFFICER
 CERTIFIED THAT THE TAKE OFF AND LANDING CONDITIONS SHOWN IN PART 2 ARE WITHIN THE PERMITTED LIMITS AND THE LOAD IS SAFELY SECURED
 _____ CAPTAIN

Fig. 5. Specimen of Aircraft Weight and Balance Clearance Form

RESTRICTED

A.P. 129, VOL. 2, PART 2, SECT. 1, CHAP. 3

22. **Strength of Lashings.** To allow for loads imposed by turbulence, acceleration and deceleration, lashings should be strong enough to withstand the following stresses :—

- (a) Forward urge—four times the weight of the load.
- (b) Backward urge—twice the weight of the load.

(c) Upward urge—twice the weight of the load.

(d) Sideways urge—one and a half times the weight of the load.

Unless items of load are lashed to nearby points the lashings may be subjected to excessive stresses.

This file was downloaded
from the RTFM Library.

Link: www.scottbouch.com/rtfm

Please see site for usage terms,
and more aircraft documents.

