

## CHAPTER 3

### CRACK DETECTION—METAL AND ALLOYS

#### LIST OF CONTENTS

	<i>Para.</i>		<i>Para.</i>
General ... ..	1	Typical examples of tests ... ..	25
Chalk test of metals and alloys ... ..	3	Johnson Fels method of crack detection	26
Hot fluid chalk test ... ..	5	Description of crack detector, Johnson	
Cold fluid chalk test ... ..	7	Fels type ... ..	29
Electro-magnetic test of metals and alloys—		Method of use ... ..	32
General ... ..	9	Clamping ... ..	37
Equipment ... ..	10	Operating the detector ... ..	38
Operation of electro-magnetic crack		Application of ink ... ..	39
detector ... ..	15	Demagnetising ... ..	41
Detecting agents ... ..	18	Maintenance of Johnson Fels crack	
Demagnetising after test ... ..	20	detector ... ..	42
General observations ... ..	21		

#### LIST OF ILLUSTRATIONS

	<i>Fig.</i>		<i>Fig.</i>
Crack detectors—electro-magnetic ... ..	1	Electrical circuit diagram, 3-point crack	
Electro-magnetic crack detection—typical		detector ... ..	5
examples of tests ... ..	2	Arrangement of rod fitting for pinions,	
Electro-magnetic crack detection—typical		rings, etc. ... ..	6
examples of tests ... ..	3	Rig for clamping flat bar, wire, etc. ... ..	7
Johnson Fels crack-detector fitted with		Showing clamping points to disclose flaws	
spring-loading contacts ... ..	4	at a right angle ... ..	8

#### General

1. As a result of the general application of highly stressed metal and alloy components in the construction of the various mechanical designs, especially in regard to aircraft and aero-engines, it is imperative that a thorough examination of the material used should be made *both* before, during and after manufacture to ascertain that the material is free from cracks. This examination should also be made while the components are in service, during overhaul and in instances where there is a likelihood of damage having been caused by corrosion, accident or failure of a subsidiary component, etc.

2. It has been found that in many instances minute cracks, which can be regarded as providing a point of concentration of stress, are present in the material of a component. These cracks are sometimes discernible with the aid of a microscope but can in most cases be traced by a process of crack detection. Fatigue cracks and consequent failure of highly stressed components often have their origin in these minute cracks. It is therefore of the greatest importance that extreme care should be taken when operating the various processes of crack detection. This chapter describes the processes permissible for use in the service. It is assumed that all components to be tested have been thoroughly cleaned, degreased, etc., in accordance with service procedure.

#### CHALK TEST OF METALS AND ALLOYS

3. A satisfactory method which can be generally applied for the detection of cracks in metals and alloys is known as the chalk test. There are two processes for this test, i.e. hot and cold. The hot test is the more satisfactory but, owing to the equipment required, it can only be applied to the smaller components. Briefly, the test consists of immersing the component in a bath of hot fluid, removing and drying it, covering with french chalk and then allowing it to cool off. The principle of the process is that on immersion in the hot fluid the material will expand and allow the fluid to enter any cracks that may be present. On cooling off, the material will contract and force the fluid out of the cracks and at the same time stain the french chalk. The mark so made indicates the presence and location of cracks or porous material.

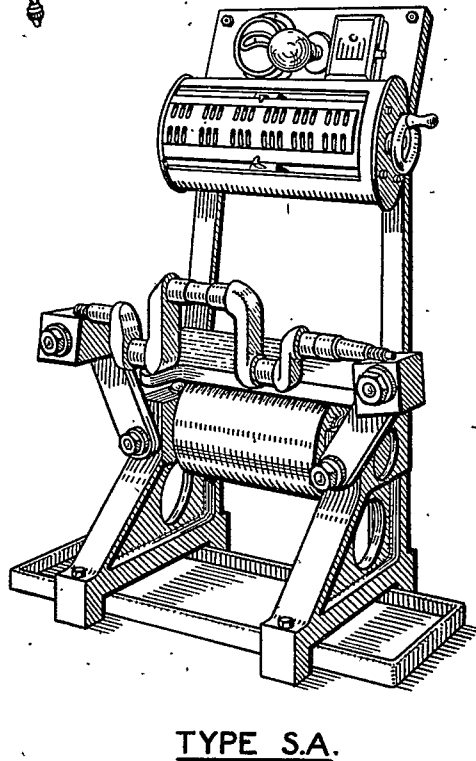
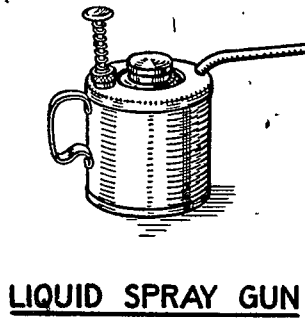
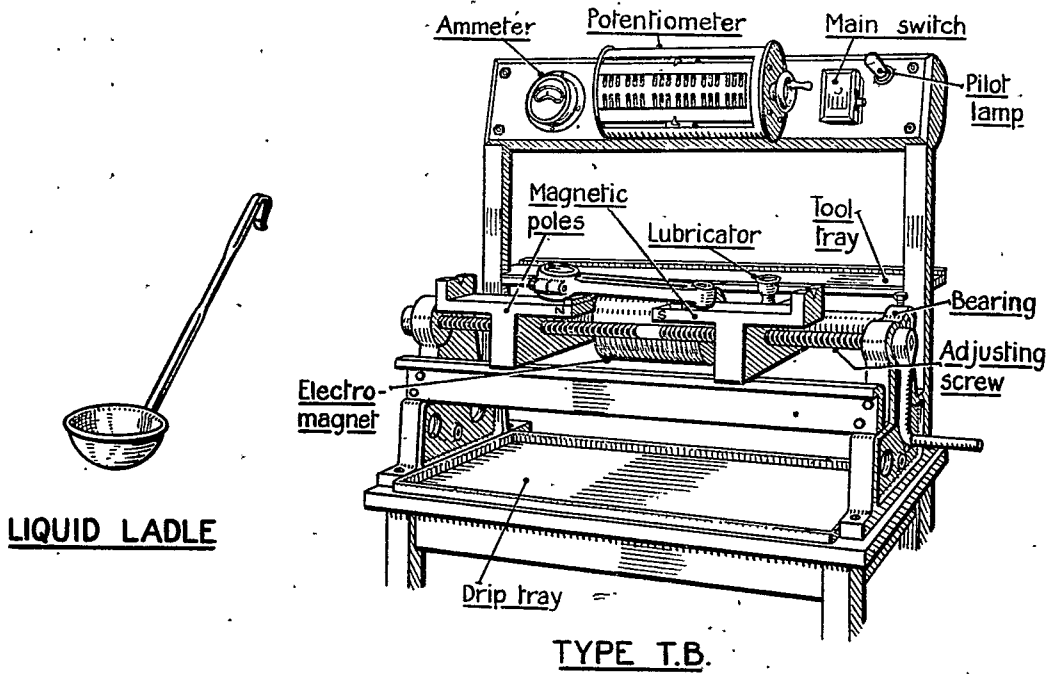

Fig. 1—Crack detectors—electro-magnetic

4. The cold test can be used on the larger components and in many instances can be applied to them without dismantling. This test consists of cleaning the material with a fluid (mixture of paraffin and oil), wiping it dry and then painting on a mixture of french chalk and methylated spirits. The principle of the process is that cleaning fluid will be retained in any cracks that may be present, while the methylated spirit will evaporate leaving a thin deposit of french chalk which in turn will be marked by the fluid retained in the cracks, so indicating the location of cracks or porous material.

#### **Hot fluid chalk test**

5. *Apparatus required and fluid used.*—The apparatus required and fluid used for the hot fluid chalk test is as follows:—

- (i) A steam heated tank or bath with a capacity of 10 to 15 gallons; the tank should be equipped with a heating device capable of controlling the temperature of the fluid.
- (ii) A flat tray approximately 4 ft. × 2 ft. 6 in., and 3 in. deep; a standard drip tray (see A.P.1086) can be employed for this purpose.
- (iii) A mixture of paraffin (3 parts) and lubricating oil, D.T.D.109 (1 part). A sufficient quantity of fluid should be mixed to suit requirements.
- (iv) Finely ground and perfectly dry french chalk.

6. *General procedure.*—The general procedure for the hot fluid chalk test is as follows:—

- (i) Heat the fluid— in the tank or bath and maintain it at a temperature of 90 degrees centigrade (194° F.).
- (ii) Spread a thick layer of french chalk over the bottom of the large tray.
- (iii) Immerse the components to be tested in the hot fluid and leave them until they reach the same temperature as the fluid (90° C.); a number of components can be tested at the same time (dependent on size).
- (iv) Remove components from the fluid and wipe them perfectly dry with clean rag; this operation must be done as quickly as possible in order to retain the heat.
- (v) While still hot roll the components in the french chalk until they are completely covered with it.
- (vi) Remove all surplus french chalk from the components by lightly tapping them on a bench or wooden block.
- (vii) Stand the components on one side until they cool off, when they should be thoroughly examined. In the event of porous or cracked material the french chalk will become yellowish in tinge around the faulty area.

#### **Cold fluid chalk test**

7. The cold fluid chalk test should be employed when dealing with components that are too unwieldy to be immersed in a fluid bath, also in instances where a suspected area is inaccessible and the component cannot be readily dismantled. The process has a very wide application in regard to general engineering, but it is of the greatest importance that tests should be carefully undertaken and if at all doubtful applied several times to the same area; this is to prevent condemning serviceable components which for some other reason may have retained oil or fluid which has marked the french chalk, and by so doing given a false impression.

8. *General procedure.*—The following is the general procedure for the cold fluid chalk test:—

- (i) Mix a quantity of paraffin (3 parts) and lubricating oil, D.T.D.109 (1 part); sufficient to meet requirements.
- (ii) Make up a mixture of methylated spirit and finely ground french chalk to a consistency that, when painted on a surface with a brush, will leave a thin coating of french chalk after the spirit has evaporated.
- (iii) Thoroughly wash down the area to be tested with the paraffin/oil fluid, and carefully dry off with clean rag.
- (iv) Using a brush carefully paint the area concerned with the methylated spirit and french chalk mixture. Allow to dry.
- (v) A careful examination should now be made. Signs of porous material or cracks will be indicated by the french chalk, which will become yellowish in tinge around the affected area.

## ELECTRO-MAGNETIC TEST OF METALS AND ALLOYS

### General

9. The electro-magnetic process of crack detection necessitates magnetising the material concerned and can therefore only be applied to ferrous metals. The process can be widely applied in service depots, but special equipment and detecting agents are required. Briefly, the process consists of highly magnetising the item to be tested and then observing any disturbance of the magnetic flux due to cracks or faults. This is achieved by means of a controlled electro-magnet, the two poles of which are so designed that when a steel or iron component is laid across them it will complete a closed magnetic circuit of low inductance. Whilst in this state a detecting agent, in the form of a liquid or powder, is poured or sprayed on to the material. If a crack exists the lines of magnetic force will be broken and will emerge on to the surface of the material, forming opposite poles and causing granules (incorporated in the detecting agent) to adhere to the edges of the crack. It has been found that if this process is correctly applied, cracks which are imperceptible through a magnifying glass can be clearly defined.

### Equipment

10. Fig. 1 illustrates two types of electro-magnetic crack detectors together with a non-magnetic (brass) ladle and spray guns for use with the detecting agents. The principle of detection and method of operation of both types is similar, but the adjustment of the magnetic poles and the size vary considerably. A brief description of the two types is given in paras. 11 and 12.

11. *Type T.B. crack detector.*—This apparatus (see fig. 1) is intended for use when testing items of various shapes, and lengths to a maximum of 62 in. The construction consists of a steel framework, which can be mounted on a table or bench, carrying the electro-magnet in the centre. The two pole limbs of the magnet are supported by bearings at each end and are mounted on a hand-operated adjusting screw. Each pole limb is provided with V-blocks, and bearing plates to which various jigs may be bolted to suit the work in hand. The rear portion of the framework consists of two uprights carrying a tool tray and an instrument board which contains a main switch, potentiometer and an ammeter. A drip tray situated between the feet of the apparatus is provided to collect the detecting liquid as it is poured or sprayed during test.

12. *Type S.A. crack detector.*—This crack detector (see fig. 1) is similar in construction to the type T.B. described above but is much smaller and only capable of testing items to a maximum length of 24 in. Also the method of adjusting the pole limbs is different. In this case the pole limbs consist of two vertical swinging arms carrying adjustable pole blocks at the ends. The method of adjusting the pole arms and blocks is by securing nuts which are clearly shown in the illustration. For repetition work the pole arms can be fitted with jigs of various designs to suit items being tested, or a brass block may be screwed on to the side of one pole block so that an air gap of definite length is maintained.

13. *Installation of equipment.*—The crack detectors should be erected on a strong wooden table or bench in a position free from draughts and where a good light is available. A large lamp with a reflecting shade should be placed immediately above the apparatus where the items are tested. On no account must the apparatus be installed on an iron floor or an iron-covered bench, or in close proximity to steel joists etc., running in such a manner that they tend to interfere with the magnetic flow. The apparatus when in operation must be placed at a good distance from delicate instruments, clocks etc., in order to prevent the powerful magnetic field from upsetting their mechanism. Personnel should remove watches and similar articles from their pockets prior to operating or approaching the apparatus when in use.

14. *Maintenance.*—The apparatus and the area surrounding it should be kept clean at all times. The drip trays supplied should be carefully placed to collect the detecting liquid which, apart from salvaging for re-application, if allowed to accumulate around the apparatus will be detrimental to its efficiency; this also applies to the detecting powder. All bright parts of the apparatus should be carefully wiped and kept clear from corrosion. The working parts such as adjusting screws and bearings should be suitably lubricated. All electrical contacts should be periodically examined, cleaned and tightened. The lead screws of the potentiometer and the pivots of the gear wheels should be lubricated frequently to enable them to work freely. The contacts on the wire-wound resistance coil (potentiometer) should be examined periodically and a small amount of vaseline applied, to enable them to pass freely over the wire without cutting or damaging it. When lifting heavy items on to the crack detector care must be taken to ensure that they do not come into contact with the instruments or the casing of the electro-magnet; these parts can be easily damaged by careless handling of heavy test items.

### Operation of electro-magnetic crack detector

15. To obtain the best results when operating this apparatus it is of the greatest importance that the correct degree of magnetism is applied to the item under test (see para. 16). The positioning

of the work on the apparatus prior to testing will greatly depend upon the circumstances, i.e. size and shape of the item concerned, but a general guide in this direction will be found in the typical test examples given in para. 25. Prior to setting up the work and making the test, the general observations given in para. 21 should be read. To prevent condemning serviceable material and components only competent personnel should be employed and under strict supervision. On the other hand, the test must be carefully done in order not to miss any cracks, especially in highly stressed components. The procedure for operating the electro-magnetic crack detectors is given here:—

- (i) Before setting up any work on the apparatus the main switch must be in the "off" position and the potentiometer sliders set at the central (zero) position.
- (ii) Set up the work in the apparatus. The best position will depend on the circumstances of individual cases, but if possible the area to be tested should lie level or slightly tilted to facilitate the flowing of the detecting agent. The work should be placed across the magnetic poles so that reasonable contact is made with each pole. In instances where there is only a small area of contact between the work and the magnetic poles, the magnetic conductivity should be improved by placing iron packing pieces round the ends of the work and resting on the pole plates. For repetition testing iron jigs should be made up and screwed to the pole plates, to suit requirements. A jig constructed of material which is a non-conductor of magnetism (brass, etc.) can often be used to great advantage in repetition work; this jig forms a permanent air gap and thus, if correctly proportioned, will ensure the desired degree of magnetism being applied to similar items. The correct proportions of the jig can be easily determined by experiment (see Adjustment of magnetic strength, para. 16).
- (iii) After positioning the work to the best advantage the electro-magnet should be energised by placing the main switch in the "on" position. The correct degree of magnetism should now be applied to the work by means of the potentiometer (see para. 16) and a trial of the detecting agent. When satisfied that this has been attained to the best advantage, all settings should be left and the current cut off by the main switch. The work should be wiped down prior to making final tests.
- (iv) Make the final test by re-energising the electro-magnet, and apply the detecting agent as described in para. 18; several tests should be made and if the result is at all doubtful the work should be set up again in a different position and the test procedure recommenced.
- (v) After making tests all items that have been magnetised should be de-magnetised as explained in para. 20.

16. *Adjustment of magnetic strength.*—The current reading of the ammeter is a direct measure of the amount of magnetism applied. This amount can be adjusted by means of the potentiometer to suit the length and section of the item on test, i.e. by turning the handle of the potentiometer the sliders are moved outwards from the central (zero) position to any desired position within the capacity of the windings; the greater the movement of the sliders from the central (zero) position so the more magnetism is applied, which will show as a corresponding increase on the readings of the ammeter. No definite position can be given for the various lengths and sections of items, owing to the variation in length of magnetic conductivity and other features which govern the reluctance of a magnetic circuit, but the best adjustment of the potentiometer will be readily found by experiment.

17. If too great an amount of magnetism is applied to a section of an item on test there is a likelihood of the magnetism extruding outside the surface of the material. This state will be indicated by an application of the detecting agent, the granules of which will, more or less, adhere all over the surface of the material in the form of a scale or fur. The correct degree of magnetism should be such that this state is just avoided. On the other hand, should the amount of magnetism be too weak the lines of magnetic force will tend to curve round any cracks (that may be present) internally without reaching the surface of the material, failing to attract the granules of the detecting agent, and leading to the possibility of the cracks being missed. To minimise this risk several tests should be made with varying potentiometer settings; this of course does not apply to repetition work where the correct setting is known.

### Detecting agents

18. There are two detecting agents for use with the electro-magnetic process of crack detection, i.e. liquid and powder. The indication of cracks given by both methods is similar, but the application varies. The liquid method is in most instances the more economical and easier to apply. A description of the application of the two methods is given here:—

- (i) *Liquid method.*—This method can be applied with either the spray gun or ladle illustrated in fig. 1. On opening a new container of the liquid which has been standing for a long period

it will be found that there is a thick sediment which has become a cake at the bottom. This must be mixed with the free solution before application; a piece of dry wood should be used to prise the sediment free from the bottom of the container, the sediment should be broken up and the whole stirred until well mixed. When applying the liquid for test purposes the use of too thick a solution should be avoided. The liquid should flow gently and evenly over the surface of the test material. The best procedure is if possible, to employ the ladle in the following manner:—Thoroughly stir the liquid with the ladle, which must be perfectly clean and free from sediment, and while gently stirring pour the contents of the ladle slowly over the surface of the item on test. When searching for minute cracks, especially in small components, it is often preferable to use the liquid spray gun illustrated in fig. 1. It is, however, essential in all instances that the liquid is of such a consistency that when poured or sprayed over the item on test it will, with the exception of the granules attracted, flow freely off the item and leave it quite clear; to assist this action the surface of the item concerned should have been arranged with a slight tilt as explained in para. 15, sub-para. (ii). If the liquid is correctly applied any cracks will show up as a definite black line generally rather rough in character.

- (ii) *Powder method.*—It will be found that with certain items such as rough castings or forgings that this method is preferable to the liquid method. To apply the powder detecting agent the powder spray gun illustrated in fig. 1 should be used. The gun should be approximately half filled with powder, and then held over the area concerned with the nozzle downwards. It should then be gently shaken and at the same time the rubber bulb gently squeezed. A small quantity of the powder will then be ejected in the form of a spray which should be directed on to the desired area. The nozzle of the gun should not be held too close to the work so that the powder falls and is not blown on to it. The surplus powder should now be blown away (a small bellows will facilitate this operation) when any cracks present in the material will be revealed in a similar manner to those indicated by the fluid method.

19. *Maintenance of detecting liquids.*—The detecting liquid is an expensive item and should therefore be used with due consideration regarding economy. If kept clean and in the correct proportions it can be used many times and over a considerable period. It is important to remember that each container of the liquid is definitely proportioned regarding sediment (granules) and free liquid and should be constantly stirred when in use to avoid the contents from becoming too thick through loss of the free liquid. The drip trays provided for collecting the liquid during the pouring or spraying operations should be kept perfectly clean at all times. After continuous testing the drip tray will become full when it should be slightly tilted and the sediment brushed to one corner, where together with the free liquid it can be returned to the container. Should there be any oil, grease or foreign matter, which cannot be removed, in the liquid the whole should be thrown away to prevent contamination of the remaining liquid in the container. The lid of the container should always be replaced after use and reasonable precautions taken to prevent foreign matter from entering the container; this especially applies to water or moisture which has a particularly detrimental effect to the quality of the liquid.

#### **Demagnetising after test**

20. It is necessary for many reasons that items should be demagnetised after test. For all practical purposes this operation can be done with the existing equipment, but in instances where it is necessary to remove absolutely all traces of permanent magnetism, as in the case of drills, taps, etc., special equipment is required. It is advisable unless such equipment is available that these items should not be subjected to the electro-magnetic process. To demagnetise with the existing equipment the following procedure should be followed:—

- (i) At the conclusion of a test, prior to switching off the apparatus the potentiometer sliders should be returned to the central (zero) position. At this position a certain amount of residual magnetism is present in the item on test, the amount being dependent on the grade of material and degree of magnetism that has been applied to it.
- (ii) With the apparatus still switched on, move the sliders of the potentiometer in an opposite direction to that used for the application of magnetism, and bring them back again to the central (zero) position. Repeat this movement several times reducing the amount of travel each time until finally bringing the sliders to rest at zero. When this final movement is reached the apparatus should be switched off.
- (iii) Remove all demagnetised items from the vicinity of the apparatus before again switching on, or they will tend to become re-magnetised by stray influence.

#### **General observations**

21. The following general observations are made to help in the detecting of cracks but in many instances individual attention and forethought must be given to the item concerned. The design

of highly stressed and other components should be carefully considered to decide at which point stress has taken place, and a very careful search made at these points to reveal minute cracks. The detecting agents will often show as blurred marks when testing with the electro-magnetic process. These marks should not necessarily be regarded as denoting cracks as they are often caused by the distortion of the magnetic field where sharp corners occur, or where a severe change in section of the material is encountered; if any doubt exists the item should be wiped dry, arranged at another angle on the apparatus and if necessary several tests repeated.

22. It should be observed that cracks in general are of two definite kinds, i.e. those due to stress as a result of use, and those due to stress set up during the process of manufacture. The former category is productive of the most definite form of crack where the material tends to part along the surface, as a preliminary to a complete fracture, and this form of crack is in many instances absolutely invisible. These cracks when revealed by the electro-magnetic process rarely follow a straight or direct line but take a sinuous form which cannot be easily mistaken during test. A tool mark is generally indicated by a straight line which will run right around the bar. In cast iron and similar brittle ferrous metals the cracks are usually very sinuous in character and often terminate and restart in an adjacent parallel path.

23. In the case of unused manufactured items cracks are often more difficult to detect as they are usually the result of imperfect heat treatment or a similar process. Heat treatment may set up internal stress and produce minute fissures which are revealed under test in the form of line hair-line cracks on the surface of the material. These cracks usually occur in hardened steel items, e.g. at the roots of the teeth of hardened steel pinions. An item of this description should be tested by applying the magnetism locally to the area suspected. Grinding processes are often the cause of cracks (due to local heat) which are generally revealed in clusters. With drop forgings a seam is sometimes formed where the two halves of the die close on each other and as a result a fold is formed in the material, enclosing a cavity which under test will show up in a similar manner to a crack; the depth of this fault, which is usually superficial, can be determined by filing away the material to remove the fold and producing a smooth surface. Lapped or welded seams in tubes will be revealed under test in instances where the weld or lap is imperfect; in both these cases the tube should be placed on the testing apparatus so that the lines of magnetic force pass across the diameter and not along the length of tube.

24. To reveal cracks distinctly it is always advisable to place items concerned in such a position on the magnetic poles that any suspected cracks will be at right angles to the direction of the magnetic lines (see Typical test examples, para. 25, figs. 2 and 3). Cracks, however, will be revealed when parallel to the magnetic lines but not with the same intensity, and it is therefore advisable to test in both directions if possible. An indication of the depth of a crack will be given by the amount of built-up deposit (granules) upon it, i.e. the greater the deposit so the deeper the crack.

#### Typical examples of tests

25. Figs. 2 and 3 illustrate typical methods of testing for cracks with the electro-magnetic process. In the illustrations the magnetic poles of the detector are shown as N and S. The following is an explanation of the various sketches contained in the two illustrations:—

(i) *Fig. 2. Sketch I.*—This sketch illustrates a standard method of revealing transverse cracks

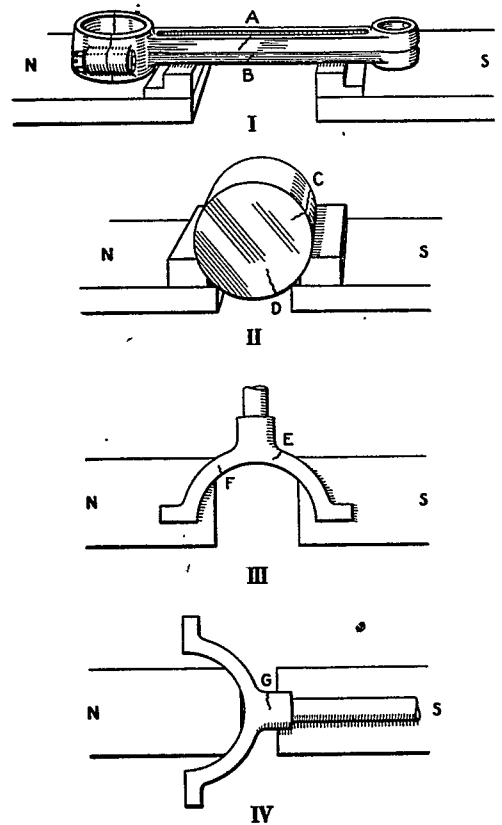

Fig. 2—Electro-magnetic crack detection—  
typical examples of tests

in items of a straight nature. In the instance illustrated it will be seen that iron packing blocks have been used to make magnetic contact with the poles (N and S). The poles should be adjusted as far apart as possible so that the magnetic lines flow through the full length of the item. Cracks appear as shown at (A and B).

(ii) *Fig. 2. Sketch II.*—This illustrates the method of testing cylindrical items for radial (D) and longitudinal (C) cracks. Iron packing blocks are used to improve the magnetic contact with the poles. The items should be tested several times turning it slightly after each test.

(iii) *Fig. 2. Sketches III and IV.* This illustration is intended to give an indication of the method of testing odd-shaped items. The item should in the first place be tested as illustrated in sketch III to reveal cracks in the arms as shown at (E and F). The second test illustrated in sketch IV reveals cracks in the boss of the item as shown at (G). The rod of the item would, of course, be tested as illustrated in sketch I.

(iv) *Fig. 3. Sketch V.*—This illustration is again intended to give an indication for testing odd-shaped items, but with the addition of a jig bolted on to the pole (N) of the apparatus. This jig ensures good magnetic contact and would be of great advantage for repetition work. Jigs should be made of wrought iron and shaped to suit requirements. Cracks are shown in this illustration at (H and J).

(v) *Fig. 3. Sketch VI.*—This demonstrates the method of testing tubular items such as cylinder liners, etc. Bolted on jigs shaped to suit requirements are employed, which enable the item to be turned and at the same time make good magnetic contact during test. A crack is revealed at (K) in the illustration.

(vi) *Fig. 3. Sketch VII.*—This illustration indicates a method of testing small or very thin items, e.g. diaphragms, dies, etc., by immersion. A shallow brass tray is placed on the poles as illustrated. The tray is then partly filled with a thin mixture of the detecting liquid. The item to be tested is immersed in the liquid which is then gently stirred with a brush. If any cracks are present they will be revealed by the sediment (granules) in the usual manner. In this test the brass tray forms an air gap for the magnetic lines and the correct degree of magnetism to apply will be found by experiment and will depend on the size and thickness of the tray.

(vii) *Fig. 3 Sketch VIII.*—This illustration gives an indication of the method of testing rods, flying wires, etc., of a considerable length. Rollers should be fixed to the poles and the items on test drawn over them by hand. The rollers and fitting must be constructed of ferrous metal, and during test it must be ensured that the item concerned is making good magnetic contact while being drawn through them. When dealing with very long items or during repetition work an arrangement to provide a continuous flow of detecting liquid can readily be rigged up, but it must be taken into consideration that the detecting liquid will require constant stirring during test. In the illustration a crack is revealed at (L).

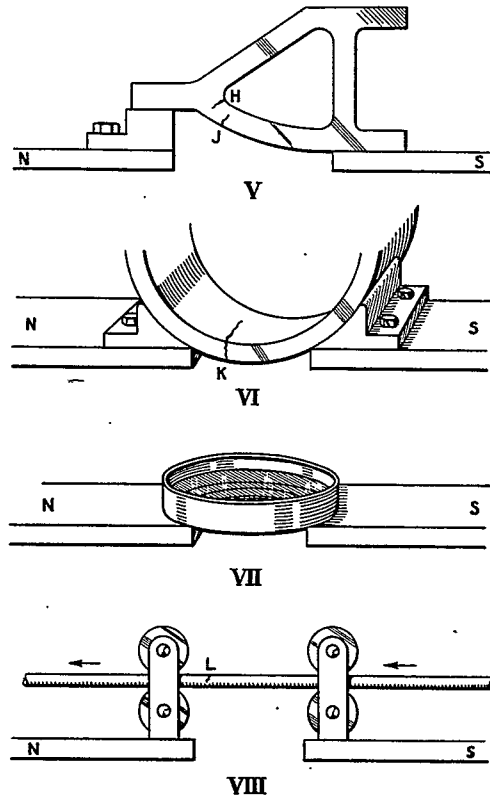

Fig. 3—Electro-magnetic crack detection—typical examples of tests

### Johnson Fels method of crack detection

26. The Johnson Fels method of crack detection in ferrous metals, differs from those described in preceding paragraphs in that the specimens tested in the machine do not show an external field unless a crack is present and, when subsequently tested for residual magnetism they appear non-magnetic. The magnetic field is produced in the part which is to be tested by passing a heavy current

through it, from a suitable alternating-current supply, as an impulse of short duration and not a sustained flow.

27. After test, demagnetisation is only necessary in exceptional cases, dependent on the degree of hardness of the part although to some extent its shape will have some influence upon the length of time over which the magnetising effect will last. On steel with a low carbon content the effect will remain for approximately six hours, whereas in high carbon and certain alloy steels the effect may last for three months.

28. Coloured detector ink is employed as the medium by means of which any cracks or flaws are made visible in parts being tested. The ink carries very finely divided iron particles in suspension, which take up their position alongside any crack or flaw that may be present when the ink is poured over a test piece which has been magnetised in the machine. It should be noted that non-magnetic or feebly-magnetic ferrous alloys cannot be tested by this method.

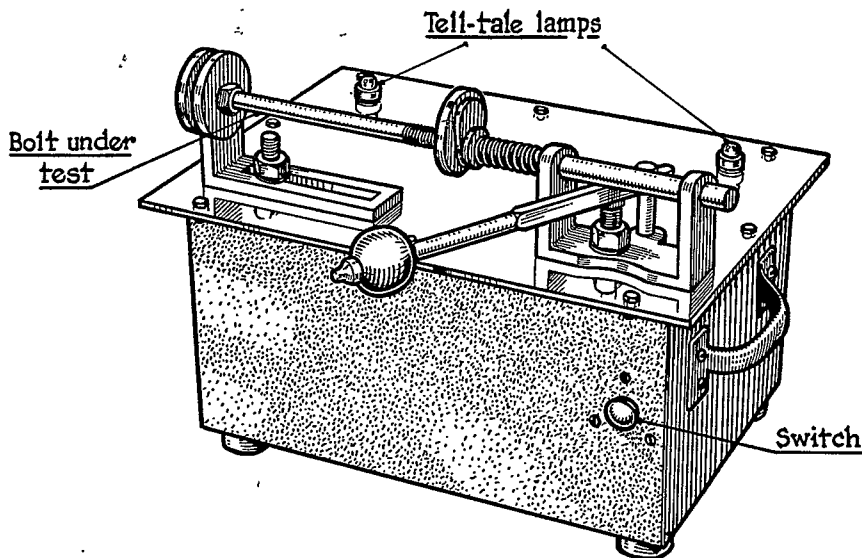

Fig. 4—Johnson Fels crack-detector fitted with spring-loading contacts

#### Description of crack detector, Johnson Fels type

29. Johnson Fels crack detector (see fig. 4) consists of a transformer and impulse coils housed within a heavy gauge sheet-steel case, having a top panel made from black bakelite. Two pilot lamps are fitted on the top of the panel and are included in the electrical circuit (see fig. 5), one, coloured red, warns the operator when the main current is switched on, and the other is green and indicates that the machine has magnetised the part correctly when the operating switch has been pressed in momentarily. The magnetisation is effected in approximately one second.

30. Two stout terminals are provided for the attachment of various fittings (see figs. 4, 6 and 7), by means of which electrical connection is made to test pieces of different shapes and sizes; the fittings may be provided with the detector in the form of clamps, cable connections, and spring-loaded sliding connections, or special adaptors to suit the work in hand may be made up locally.

31. The supply cable is three-core, externally steel-armoured and internally earthed, and is of a suitable length to plug in to a nearby 200/250-volt, 50-cycle single-phase A.C. power point. Handles are provided on the case by means of which the machine can be easily transported from one site to another.

## Method of use

32. The method of using the Johnson Fels crack detector will depend upon the size, shape and carbon content of the parts to be tested, a large proportion of which will comprise steel components of aero-engines and airscrews. The general observations given in paras. 21 to 24 apply equally to this machine.

33. Attempts to find flaws and cracks should be made at right angles to the direction of a possible fault, except where the component to be tested is hollow or in the form of a ring; in such instances where it is possible to insert a brass or copper rod through the component across the detector terminals, any flaws which may be present will be disclosed, in all directions, in one magnetising operation.

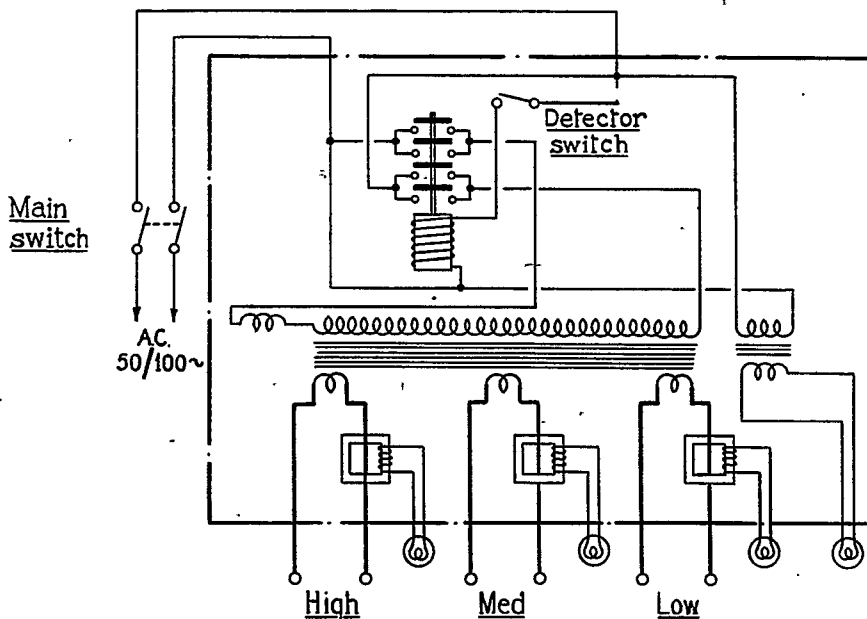

Fig. 5—Electrical circuit diagram, 3-point crack detector

34. Such components as gear wheels, ball races, gudgeon pins, milling cutters and any other parts of similar construction having a hole through the material should be magnetised on the movable bar fitting (see fig. 6). Small tubular test pieces which cannot be placed on the bar, should be threaded on to a stout piece of copper wire, which should be held at each end in the detector clamps. Bolts and similar parts can be quickly held in the detector by means of the spring-loaded plunger fitting (see fig. 4).

35. Long bars or tubes can be tested and examined in overlapping lengths along the bar or tube, in separate operations, until the whole length has been covered. The maximum length or diameter that can be tested in one operation depends to a great extent upon the carbon content; the higher the carbon content and the greater the degree of hardness, the greater the length or diameter that can be tested per operation.

36. When the component to be tested consists of a heavy crankshaft or similar object it may be supported without clamping, on V-blocks lined with brass or copper gauze, cable connections being made from the terminal posts on the detector to the V-blocks.

## Clamping

37. It is of the utmost importance when testing components by means of the detector that all electrical contact surfaces on both the component and the detector fittings are clean and free from corrosion, scale, oil or grease, otherwise the magnetisation will be unsatisfactory. Except in

such instances as mentioned in the preceding paragraph and in the case of parts held in special jigs on the machine, copper clamps should be used to make good contact with the test piece; when electric cable is used in conjunction with the clamps it should be at least  $\frac{3}{8}$  in. dia. It is essential in order to obtain satisfactory results that the area of contact should be at least  $\frac{1}{2}$  sq. in., and that the contact should be tight; point contact must be avoided.

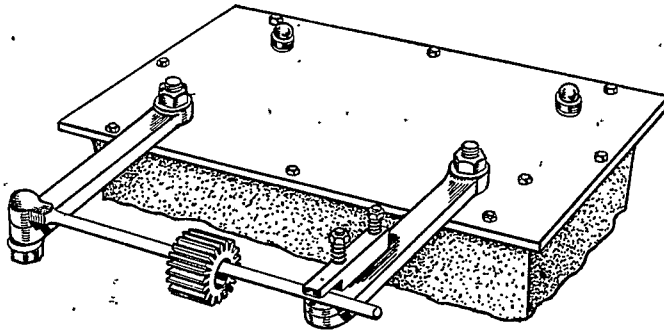

**Fig. 6—Arrangement of rod fitting for pinions, rings, etc.**

#### **Operating the detector**

38. After it has been ensured that the contacts are satisfactorily made the detector should be plugged in to the main electricity supply, which should be switched on. The red tell-tale lamp should now be alight, if not, the main feed should be checked and the fault remedied, after which the magnetising switch button should be depressed and released quickly. The green tell-tale lamp should now glow if the detector has magnetised the part correctly, if not, the contacts between the arms and the part to be tested should be cleaned, and the switch operated again.

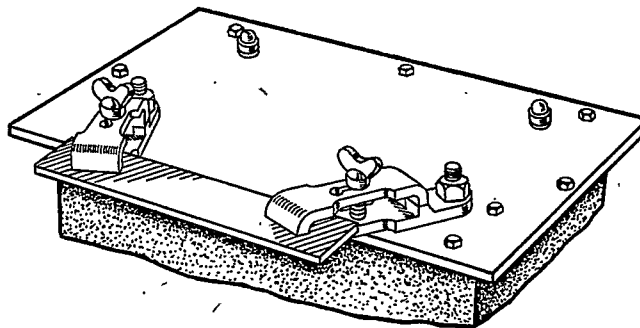

**Fig. 7—Rig for clamping flat bar, wire, etc.**

#### **Application of ink**

39. When the foregoing operation has been completed the part should be removed from the detector connections and immersed in an ink bath, or, if this is not possible, the ink should be sprayed or poured on it. Unless special equipment in the form of an ink bath and pump feed is available, the ink should be kept well-stirred before it is applied and a shallow tray should be used to catch the ink after it has been poured over the test piece. If there are any cracks at right angles to the direction of current flow in the part under test these will now be visible. When the formation of the part is such that cracks may be present in the same plane at a right angle to one another the magnetising operation should be repeated with the clamps arranged at  $90^\circ$  to the previous clamping position (see fig. 8); as already mentioned in para. 33 this does not apply to hollow objects or rings which have

been magnetised on the conductor bar of the ring jig (see fig. 6). If, after applying the ink, the marking should appear unsatisfactory for any reason, the suspected area can be cleaned and re-inked repeatedly, without re-magnetising.

40. In the cases of components having discoloured surfaces such as coil springs, stampings or forgings, any cracks may be made more plainly visible by the application of a thin coat of aluminium paint to the surface under test, before inking.

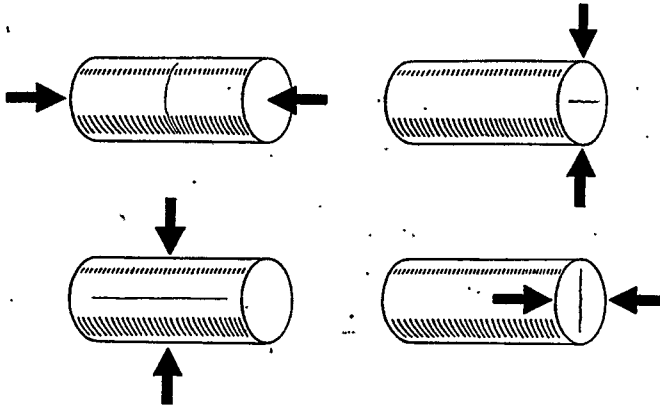

Fig. 8—Showing clamping points to disclose flaws at a right angle

#### Demagnetising

41. Components free from cracks and flaws, which have been magnetised on the Johnson Fels crack detector do not normally require demagnetising, because magnetism will only be present along a crack or faulty component. A magnetic field will be shown from tooth to tooth of a gear wheel or from one spline to another of a splined shaft, although when tested for residual magnetism the gear or shaft appear non-magnetic. As previously mentioned the magnetic effect may remain for a period of from six hours to three or four months and, if it is essential for some specific purpose that immediate demagnetisation is necessary, the component must be passed through a demagnetiser.

#### Maintenance of Johnson Fels crack detector

42. Necessary maintenance of the apparatus is limited to ensuring cleanliness of the contact surfaces on the terminal arms and clamps and serviceability of the supply cables and of the tell-tale lamps. The contact surfaces should be cleaned as necessary with a rag dipped in petrol. The supply cables should be examined periodically for signs of deterioration in the insulation and for security of the attachment of the plug, the pins of which should be cleaned as necessary. If either of the 6-volt tell-tale lamps fail to light when required, it should be examined for looseness in its holder or for faulty contact, and if still failing to light, checked for a faulty filament.

This file was downloaded  
from the RTFM Library.

Link: [www.scottbouch.com/rtfm](http://www.scottbouch.com/rtfm)

Please see site for usage terms,  
and more aircraft documents.

