

Chapter 5 . . . ALL-METAL STIFFNUTS

LIST OF CONTENTS

	PARA.		PARA.
Introduction	1	Thin nuts	12
General description	6	Notes on usage	13
Protective coating	8	Clinch nuts	19
Clinch nuts	9	Anchor nuts	20
Anchor nuts	10	Floating strip	21
Floating strip	11		

LIST OF ILLUSTRATIONS

	FIG.		FIG.
Simmonds Pinnacle nut	1	Clinch nuts	5
Oddie stiffnut	2	Clinching tools	6
Philidas nut	3	Some typical anchorages	7
G.K.N. aerotight nut	4	Floating strip	8

Introduction

1. This chapter gives information on the various metal stiffnuts used on aircraft. It includes an account of their function and a description of the nuts and their anchorages, followed by some general notes on usage.

2. A stiffnut is a nut provided with means whereby the friction between the thread of the nut and that of the standard bolt on which it is mounted is so increased that the nut may be considered self-retaining. There is necessarily a certain amount of play between the threads of an ordinary nut and a bolt owing to the manufacturing tolerances. A stiffnut, however, is so constructed that on the body of an ordinary nut is superimposed a locking device of some sort which grips the thread of the bolt and holds it firmly. As the name implies, the nut is stiff and hard to turn once the thread of the bolt engages with the locking device.

3. There are, broadly speaking, two types of stiffnut—the fibre insert nut, and the newer, all-metal nut. Stiffnuts may be simple hexagon nuts or they may be provided with anchor plates which are held by rivets to the component. The nuts may be either fixed or floating in the anchor plates and are more commonly used with screws than with bolts.

4. Stiffnuts are largely used on aircraft for attaching panels which have to be removed frequently for inspection or other purposes. For instance, access to the fuel tanks is obtained by the removal of wing panels which are held in place by rows of stiffnuts anchored behind the panel mounting. The all-metal nuts can be used at any temperature up to +500° C. and are unaffected by oil or by any fluid employed in the aircraft.

5. Stiffnuts are made in brass, mild steel, and light alloy. The brass nuts are mostly used for electrical work.

General description

6. The nuts have an addition on the top constituting the locking device, which usually consists of one or more threads which are de-pitched by about 50 per cent. As the bolt is inserted, therefore, the locking part is forced away from the main part of the nut and so grips the bolt threads tightly.

7. The all-metal stiffnuts, (Stores Ref. 28M/-) which are interchangeable among themselves, are as follows:—

(i) SIMMONDS' PINNACLE NUT.—The nut, (*see fig. 1*), has a cap of spring steel which engages with the thread on the bolt and is forced upwards by it.

(ii) ODDIE STIFFNUT.—The nut, (*see fig. 2*), is similar in action to the Pinnacle nut, but instead of having a spring steel cap fitted at the top, each side of the hexagon is extended and bent inwards to form a claw. The six claws form a circle of slightly smaller diameter than the thread of the bolt, against which they jam themselves.

(iii) PHILIDAS NUT.—The nut, (*see fig. 3*), is made with a circular crown in which two slots are milled one above the other with an arc of about 270°. The wings thus formed are de-pitched to provide the locking tension.

(iv) G.K.N. AEROTIGHT NUT.—The nut, (*see fig. 4*), is made with a circular crown which is slit across its diameter, slotted each side through about 150° and then de-pitched. In addition

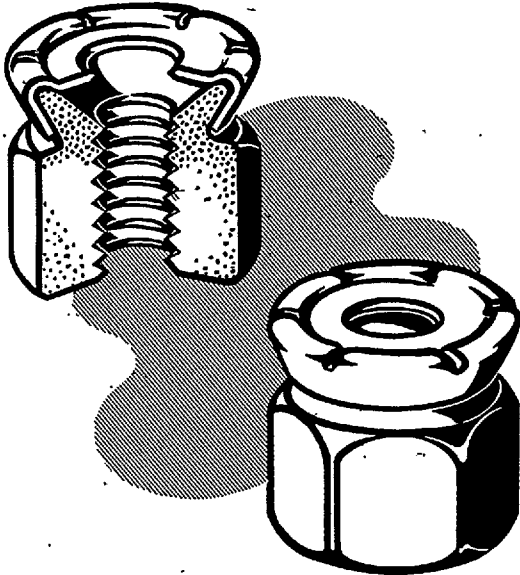

Fig. 1.—Simmonds pinnacle nut

to being de-pitched, the wings are forced inwards radially, so that there is a sideways as well as a downwards tension on the bolt.

Protective coating

8. The steel nuts are all zinc or cadmium plated except for the Philidas nut, which is Walterized, and dyed black; Walterization is a treatment based on a phosphate dip. For purposes of identification, some G.K.N. Aero-tight nuts are tinted blue, indicating that they are light alloy nuts. Brass nuts have no protective coating.

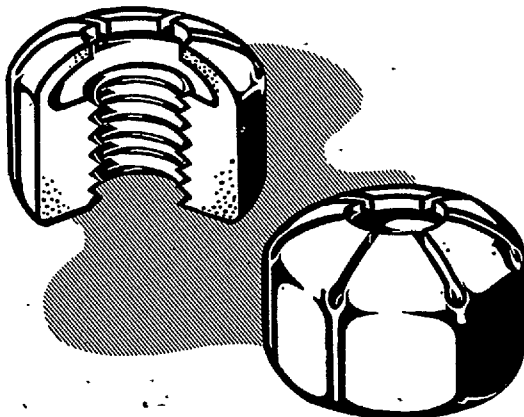

Fig. 2.—Oddie stiffnut

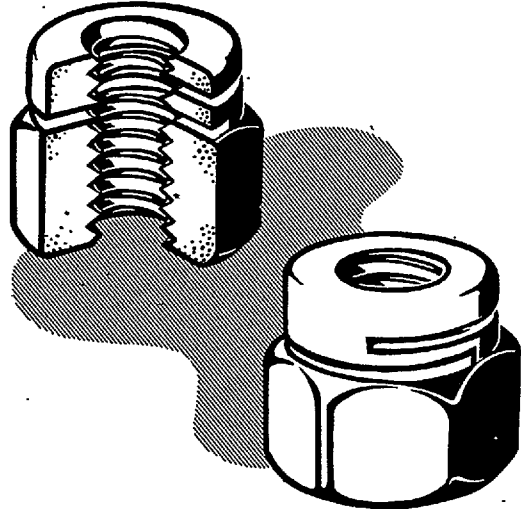

Fig. 3.—Philidas nut

Clinch nuts

9. Clinch nuts, see fig. 5, are normal stiffnuts which are mounted on their support by a flange at the bottom of the nut. The flange passes through a countersunk hole and is expanded by clinching tools as shown in fig. 6.

Anchor nuts

10. Some typical anchor plates and anchor cages are shown in fig. 7. The anchor plates are riveted on the back of the component and hold the nut so that the bolt or screw can be inserted from the front. The nut may be either fixed or floating in the anchor cage. A double anchor plate is one which is secured on

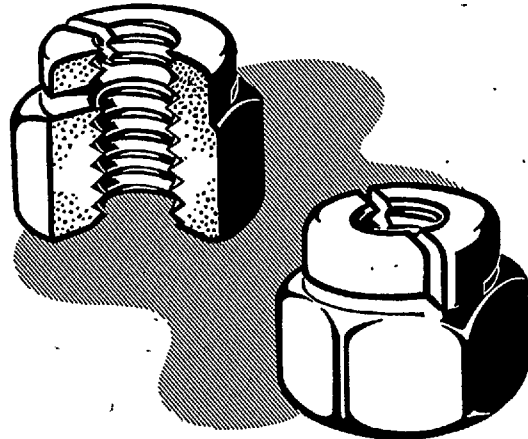

Fig. 4.—G.K.N. Aero-tight nut

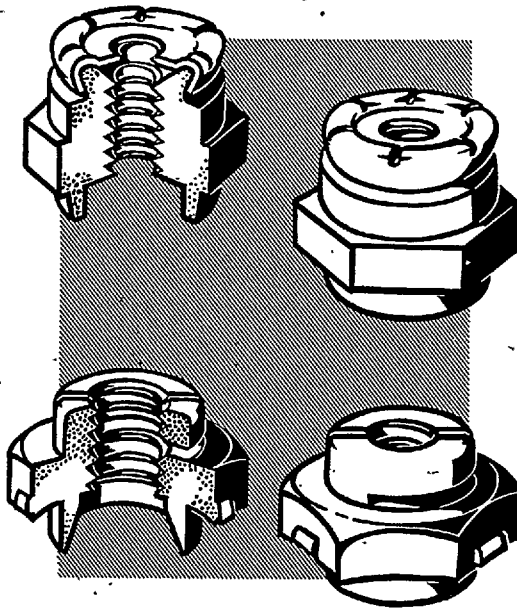

Fig. 5.—Clinch nuts

its support by two rivets while a single anchor plate is held by only one rivet. Anchor plates are made for both standard and thin hexagon nuts and consist of a metal plate to which the nut is fitted before the plate is riveted to its support.

Floating strip

11. Instead of attaching single nuts to the component, it is sometimes more convenient to use strip, on which the nuts are mounted in a row at a fixed distance apart. As shown in fig. 8, the nuts are fitted to plates which are assembled in a strip of sheet metal. The nuts have a slight amount of free movement to allow for a small margin of error.

Thin nuts

12. The range of anchor plates and cages for the thin hexagon nuts are similar to those for the standard nuts. The thin nuts are used for shear bolts only.

Notes on usage

13. The nuts can be used almost indefinitely, but as soon as the operator does not feel a reasonable torque when the bolt or screw is inserted, the nut should be renewed. On any size above 2 B.A., the nut should be more than fingertight if it is to be used again. The light alloy nuts and bolts are the quickest to wear and require most frequent renewal.

14. When a nut is discarded it should be replaced by one of the same material and having the same type of anchorage. The all-metal stiffnuts are interchangeable except for the clinch nuts. The thin hexagon nuts should only be used for shear bolts.

15. The bolt or screw which is inserted in the nut should not have a damaged thread, and there should be $1\frac{1}{2}$ clear threads showing above the top of the nut.

16. Under no circumstances should the nut be tapped out before use.

17. If the wings of a Philidas or Aerotight nut snap owing to faulty material, the nut must be discarded and a new one used. The wings are liable to snap as the bolt is screwed in or even after assembly owing to vibration.

18. No attempt should be made to restore the locking properties of the nut by hammering the wings down or squeezing them together.

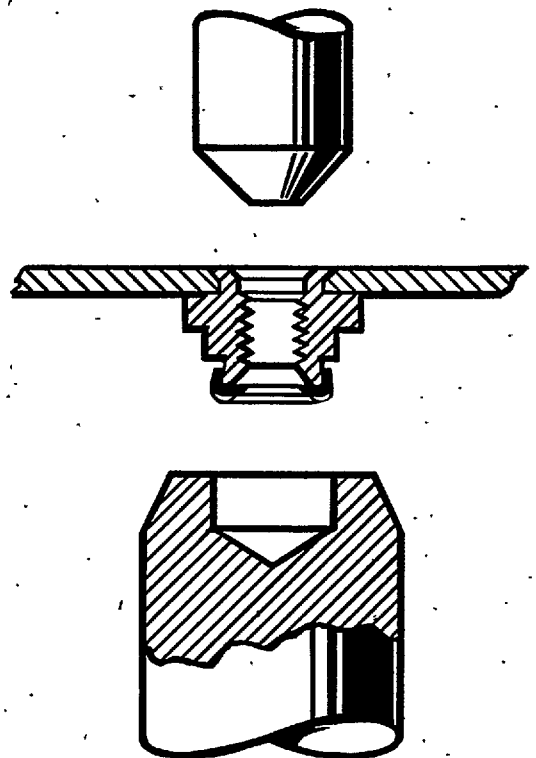

Fig. 6.—Clinching tools

ALL-METAL STIFFNUTS

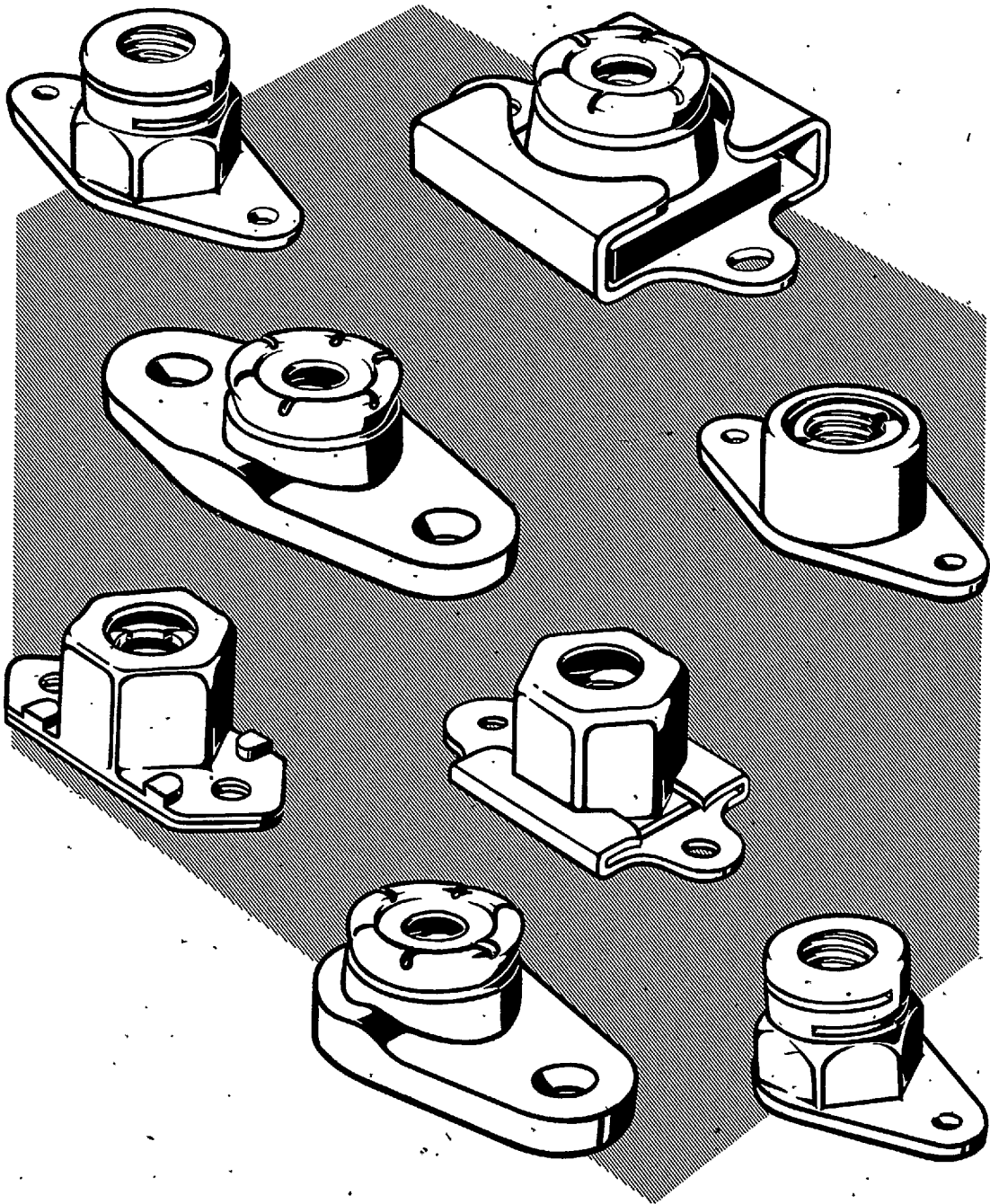

Fig. 7.—Some typical anchorages

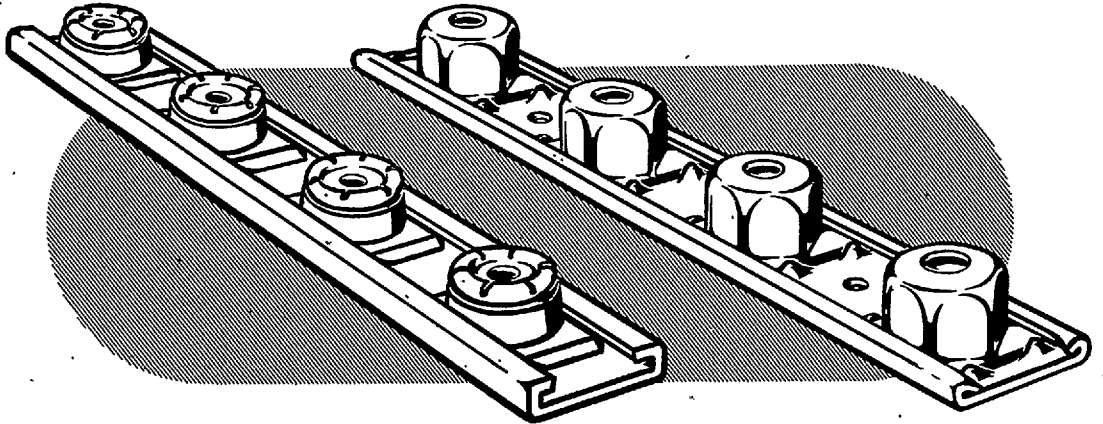

Fig. 8.—Floating strip

Clinch nuts

19. If a clinch nut turns as the bolt or screw is inserted, the nut should be removed and replaced by a new one of the same type. This is necessary because for any given size of nut the diameter of the hole required in the component varies with the type of nut.

Anchor nuts

20. Before an anchor nut is scrapped as having lost its gripping power, it should be tried with a new bolt or screw, because, often when there

is no appreciable torque, it is due to the bolt's being undersize or worn and not to the inefficiency of the nut.

Floating strip

21. Owing to the fact that in the past some strip was made of metal of too light a gauge metal, the nut was pushed right through the strip, when the screws were put back. Care should be taken, therefore, not to press too hard on the screwdriver. If one nut of a strip is pushed out the whole strip should be renewed.





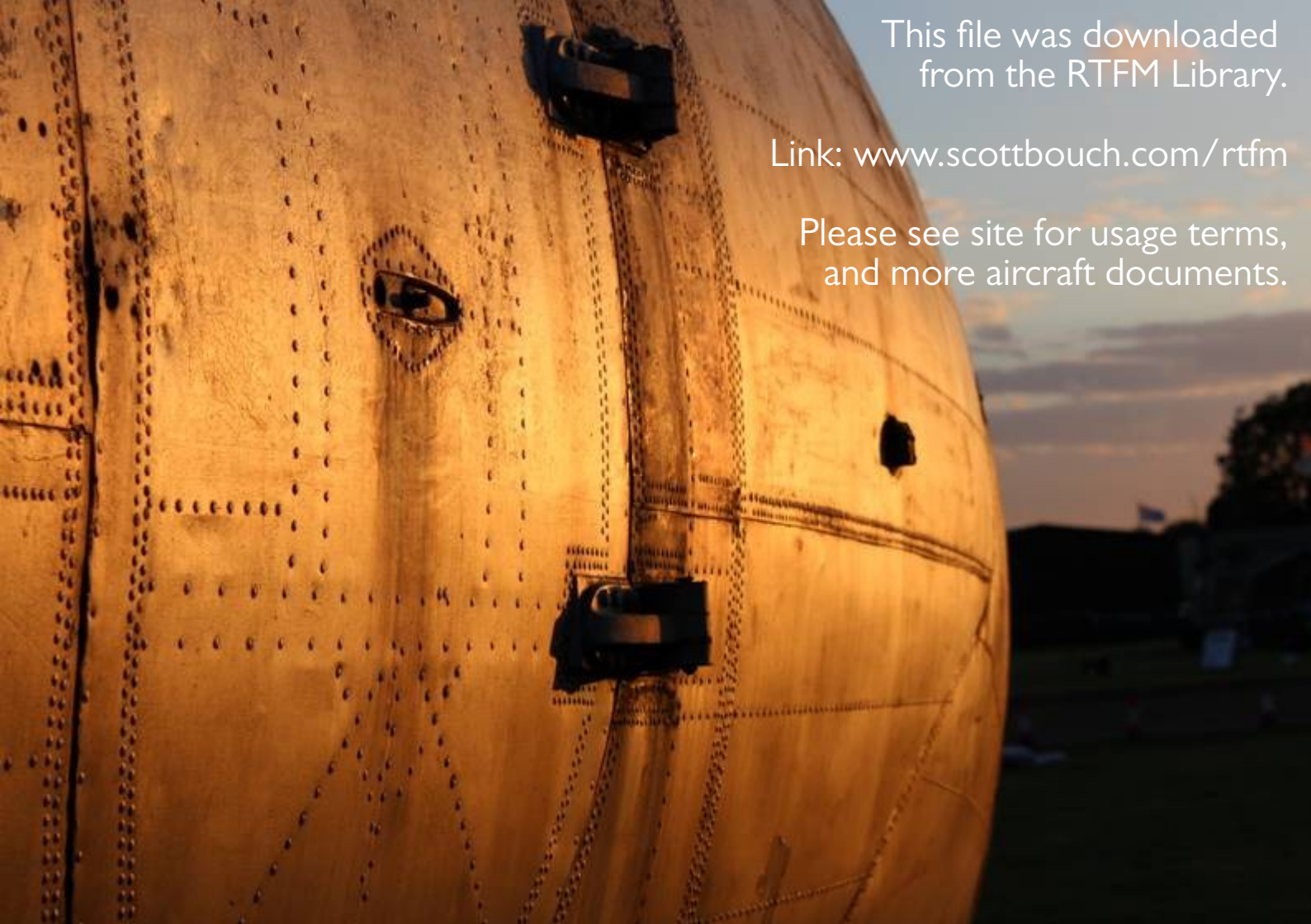

This file was downloaded
from the RTFM Library.

Link: www.scottbouch.com/rtfm

Please see site for usage terms,
and more aircraft documents.