

Chapter 5 ALIGHTING GEAR

(Completely Revised)

LIST OF CONTENTS

	Para.		Para.		Para.
DESCRIPTION AND OPERATION				REMOVAL AND ASSEMBLY	
General	1	Main wheel door	11	General... ..	26
Main undercarriage	2	Wheel door lock plungers	12	Main wheel	27
Main wheel brake units	5	Main undercarriage leg fairing	14	Main undercarriage	28
Nose undercarriage	6	Nose undercarriage adjustment	15	Main undercarriage radius rod	30
SERVICING				Teleflex cables, conduits and barrel guides	32
General	7	Nose undercarriage leg fairing and wheel door	17	Nose wheel	33
Main undercarriage adjustment		Nose wheel door lock post mod. 3572	22	Nose undercarriage unit	34
Radius rod	8	Charging and inflating the alighting gear shock-absorbers	23	Nose undercarriage radius rod	36
Radius rod attachment eye-bolt	9	Retraction tests	25	Self-centring mechanism	37
Hydraulic retraction jack	10			Nose undercarriage shock-absorber	39

LIST OF ILLUSTRATIONS

	Fig.		Fig.		Fig.
Geometry of retraction movement	1	Radius rod assembly	4	Main undercarriage	8
Main wheel door	2	Wheel door lock plungers,	5	Nose undercarriage	9
Wheel brake unit... ..	3	Torque link micro switch	6	Self-centring mechanism	10
		Nose wheel door mechanism	7		

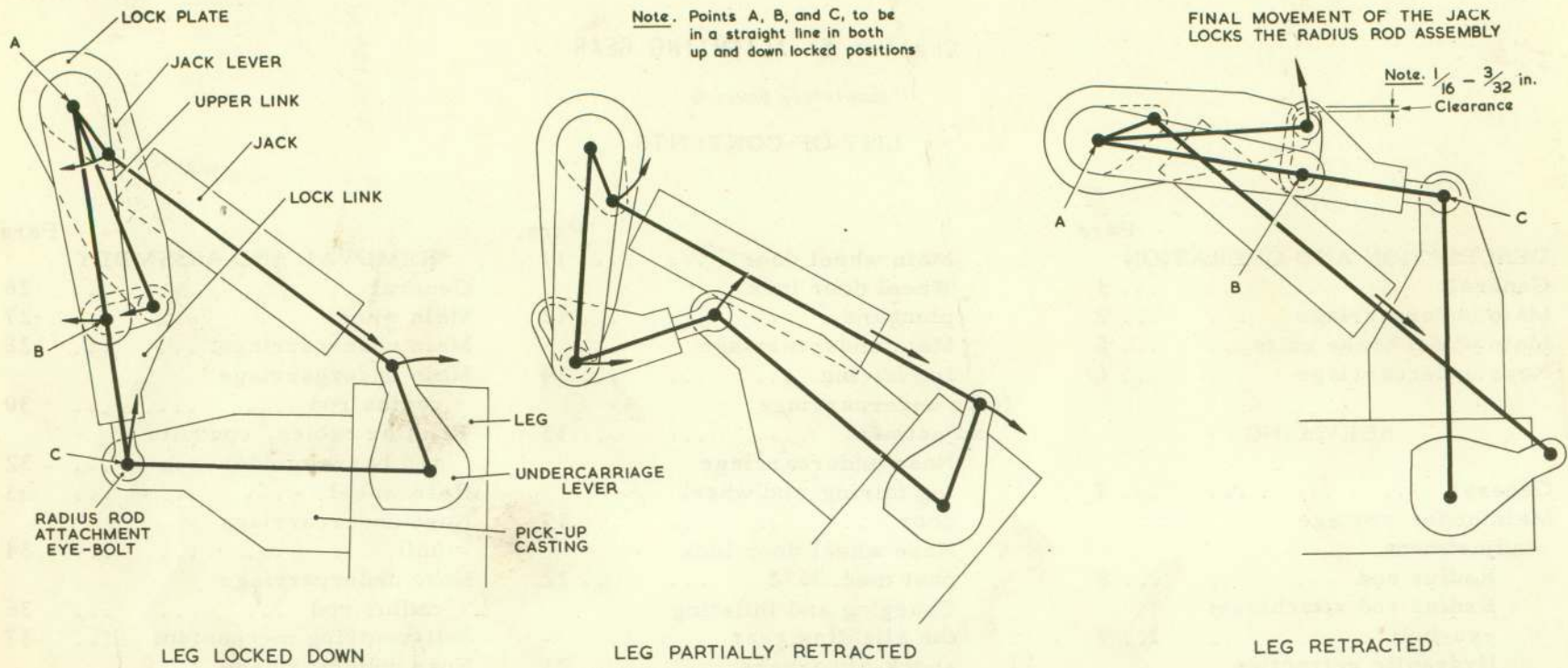

Fig.1 Geometry of retraction movement

DESCRIPTION AND OPERATION

General

1. The tricycle alighting gear consists of two main wheels fitted with Dunlop pneumatic brakes, and a single castering nose wheel, each wheel being mounted on an undercarriage leg incorporating a Lockheed shock-absorber unit which, in respect of each main undercarriage, is formed integral with the leg itself. All three undercarriage assemblies can be hydraulically retracted and, in the up position, are fully enclosed by leg fairings and hinged doors. A full description of

the shock-absorber units together with relevant dismantling, servicing, charging and inflating instructions will be found in A, P. 1803C, Vol. 1.

Main undercarriage

2. The main undercarriage legs are oleo-pneumatic in operation; each incorporates a plunger tube sliding freely in a cylinder, the shock loads being absorbed by compressed air and the telescopic action damped by fluid being forced through restrictor holes. The legs may be rendered interchangeable by reversing the position of their existing torque link

assemblies and by changing over the undercarriage levers.

3. The alighting gear is raised or lowered by the operation of a selector lever which protrudes through the aft face of the 1st pilot's engine control box on the port cabin wall. This lever is duplicated at the second pilot's position, being located in a control box on the starboard cabin wall. (Sect. 1, Chap. 1, Fig. 1.) When the weight of the aircraft is on the main wheels, the lever is locked in the DOWN position by a solenoid-operated plunger fed through a micro switch on the port

VA0305-2/1

undercarriage torque links, and thus prevents inadvertent retraction of the alighting gear when the aircraft is on the ground. The sequence of movement of the undercarriage mechanism components upon retraction is shown diagrammatically in fig. 1, whilst their general arrangement is illustrated in fig. 8.

4. Whilst the wheel door for each main undercarriage (fig. 2) is spring-loaded to both its open and closed positions, its closing movement is initiated by the abutment of the main wheel tyre against the folding door support frames during the final stages of undercarriage retraction; the security of the door in the closed position is ensured by the engagement of its two catches by individual locking plungers which are operated by Teleflex cables from the undercarriage radius rod assembly. When the alighting gear is being lowered, the initial movement of the radius rod withdraws the Teleflex-operated plungers, and allows the descending wheel to open the door until the spring struts take over to complete the door-opening sequence.

Main wheel brake units

5. A Dunlop pneumatic brake unit (fig. 3) has two expansion chambers and two separate sets of brake shoes. The operation of the brakes is described in Chapter 7 of this Section.

Nose undercarriage

6. Although the operation of the nose undercarriage is similar to that of a main undercarriage, its shock-absorber is a separate unit contained in a fully castoring leg housed within a support casting, the top of which incorporates a self-centring mechanism (fig. 10). In the retracted position, the nose undercarriage is enclosed by a hinged leg fairing, a fixed leg fairing and a mechanically-operated wheel door. The general arrangement of the nose undercarriage is illustrated in fig. 9.

SERVICING

WARNING

Except where a pressure relief valve is incorporated between the hand pump inlet and pressures lines (Mod. 3347 or 3348), the manually-operated non-return valve on the port rear face of bulkhead No. 2 must be held open whenever the hydraulic hand pump is used; failure to observe this precaution may result in serious damage to the alighting gear retracting mechanism components. Any wedge used to hold open the valve should have a red flag attached to it to prevent its being overlooked when servicing is completed.

General

7. All moving parts of the alighting gear must be kept clean and well lubricated. The components requiring

periodic lubrication, and the location and number of various points, are shown in certain illustrations. The lubrication chart in Sect. 2, Chap. 4, identifies the symbols and lubricants used. Before any servicing operations are carried out on the alighting gear, the aircraft should be safely and evenly jacked up so that all wheels are clear of the ground.

Main undercarriage adjustment

WARNING

Whenever the rigging of an undercarriage is checked or adjusted, the following sequence must be adhered to strictly.

Radius rod

8. Adjust the radius rod as follows :-

(1) With the lock plate of the radius rod assembly in the locked position (fig. 4), adjust the stop bolt between the upper link and the lock link until, with the stop faces in contact, the lock plate roller can be moved freely from one end of the kidney slot to the other; this indicates that points A, B and C (fig. 1) are in a straight line.

(2) Tighten the stop-bolt lock-nut and wire-lock the bolt and nut securely.

(3) Adjust the lock plate (leg lock) micro switch in accordance with the instructions in Sect. 5, Chap. 1.

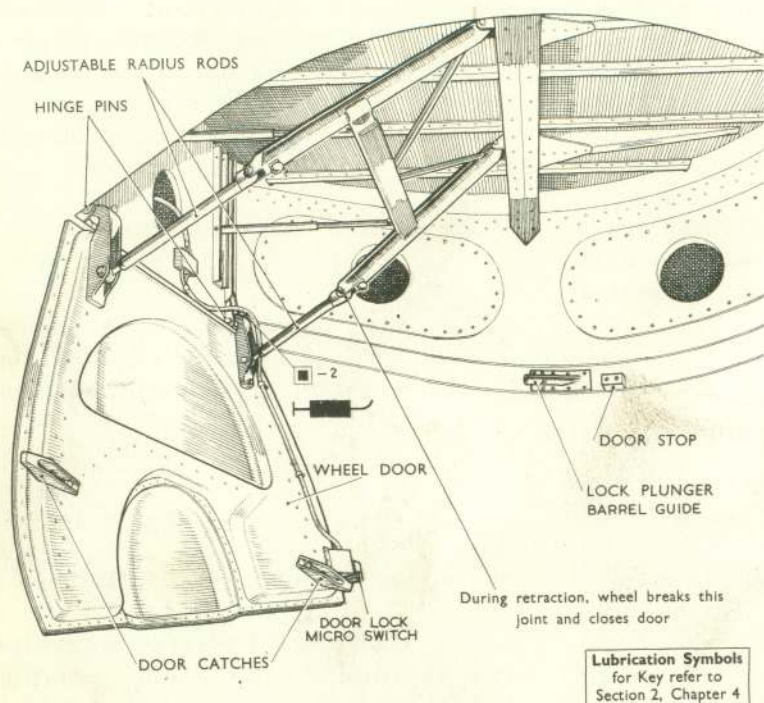

Fig. 2 Main wheel door

Radius rod attachment eye-bolt 9. The locking washer should be freed and the radius rod attachment eye-bolt (fig. 4) screwed in far enough to prevent the axle striking rib No. 4 of the main plane structure on initial retraction of the undercarriage, and thereby causing undue stressing, and possible stretching and loosening of the radius rod hinge block attachment

bolts; where, however the nominal closed pin-centre length of the jack is in doubt, it is advisable to adjust its fork end to give a length of 11 in. and to secure the lock-nut, but not the locking washer, until the instructions contained in para. 10 have been satisfied. The procedure is then as follows :-

(1) Remove the leg fairing and

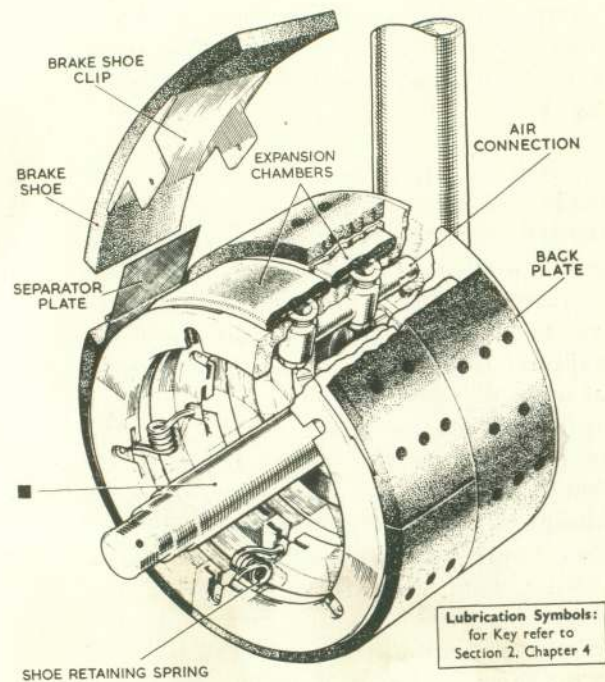

Fig. 3 Wheel brake unit

main wheel, disconnect the wheel door radius rods, and ensure that the leg is fully extended.

(2) Place a piece of plasticine on the end of the axle then, using the hand pump (WARNING preceding para. 7), retract the undercarriage to the fully UP position.

(3) Select undercarriage DOWN

and measure the thickness of the plasticine; the thickness should be 1/16 in. to 1/8 in.

(4) Screw the radius rod attachment eye-bolt in (to increase the clearance) or out, as required, re-connect it to the pick-up casting on the leg, and re-check the axle clearance in the retracted position as described above.

Note...

One half-turn of the eye-bolt equals 0.1 in. movement (approx.) at the end of the axle.

(5) Repeat the operations (2), (3) and (4) until the requisite clearance is obtained, then lock the eye-bolt with the lock-nut and locking washer.

(6) Adjust the up micro switch in the wheel well recess (fig. 8), and the alighting gear warning lamp micro switch on the aft face of the firewall, in accordance with the instructions in Sect. 5, Chap. 1.

Hydraulic retraction jack

10. With the jack ram fully extended and the leg in the fully up position, there must be a clearance of 1/16 in. to 3/32 in. between the lock plate roller and the upper end of the kidney slot (fig. 1). This clearance is critical for the satisfactory operation of the

undercarriage, and the recommended procedure for checking and adjusting it is as follows :-

(1) With the undercarriage down, select UP, and operate the hand pump (WARNING preceding para. 7) until the lock is broken.

(2) Affix a small piece of plasticine, wrapped in adhesive paper, to the inboard or upper extremity of the kidney slot.

(3) Pump the undercarriage to the fully locked up position so that the plasticine is compressed to a thickness equivalent to the clearance to be checked.

(4) Lower the undercarriage sufficiently to allow careful removal of the plasticine, and measure the thickness of the plasticine.

(5) Adjust the position of the jack ram fork end in (to increase the clearance) or out, as required, and repeat operations (1) to (4) above until the dimension is within the requisite limits.

(6) Tighten the fork end lock-nut and where applicable (Mod. Vam 3453) secure it with its locking washer.

Note...

If, after the kidney slot clearance is correctly rigged, the extension of the radius rod attachment eye-bolt is re-

adjusted, the kidney slot clearance must be re-checked and the jack ram length re-adjusted as necessary.

(7) Adjust the down micro switch in accordance with the instructions in Sect. 5, Chap. 1.

Main wheel door

11. The procedure for fitting the main wheel door is as follows :-

(1) Refit the main wheel and connect up the wheel door radius rods.

(2) Adjust the radius rods so that when the door is normally closed, the door firmly contacts its stops on the wheel well walls.

(3) Adjust each door catch to give a clearance of 0.040 in. to 0.060 in. between its underside and the top of its door lock plunger, a clearance of 0.050 in. to 0.060 in. between its end and the wheel well wall (and the edge of the main plane underskin) and a clearance of 0.050 in. to 0.100 in. between its end and the end of its lock plunger barrel guide (fig. 5). Ensure, at the same time, that a clearance of 0.050 in. to 0.150 in. exists between the door periphery and the edge of the main plane underskin.

Note...

The above clearances are most essential to prevent the catches fouling the plungers or main plane structure when the door is closed

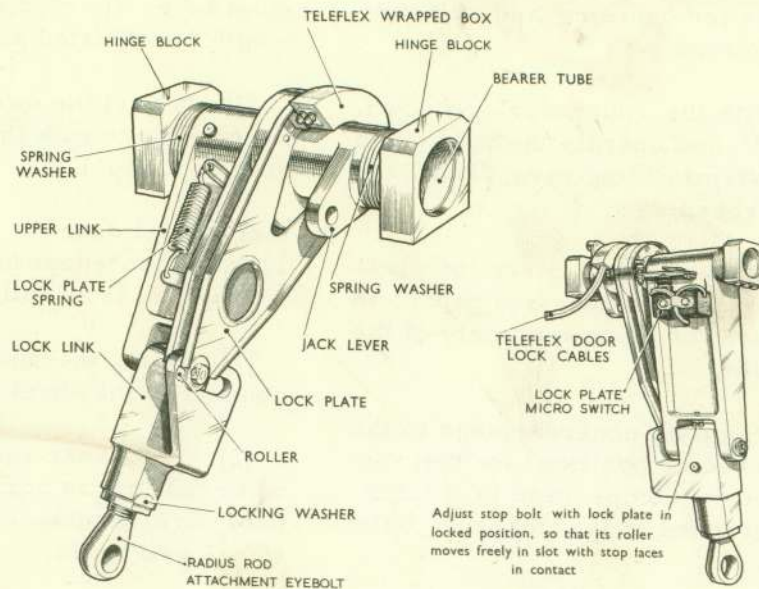

FIG. 4 RADIUS ROD ASSEMBLY

under flight conditions. After these clearances have been obtained, the door catch attachment nuts must be securely tightened and then locked by **centre-punching** their stud threads.

(4) Re-adjust the length of the radius rods so that, when the undercarriage is locked up (WARNING preceding para. 7), a load of approximately 50 lb., applied at each corner of the door, is required to pull the adjacent door catch down to just contact its lock plunger. A light finger pressure on the underside of the door (with the load still applied) should be

sufficient to lift the door catches clear of their plungers again.

(5) Check the radius rod eye ends for safety and tighten their lock-nuts, lower the undercarriage again, remove the main wheel and disconnect the wheel door radius rods.

Wheel door lock plungers
12. For routine checking of the plunger setting, fully retract the undercarriage (WARNING, preceding para. 7), and check that the annular groove around the outer end of each plunger coincides with the exposed end

of its barrel guide on the wheel well wall. If for any reason it is found necessary to dismantle the Teleflex control, the following sequence should be adhered to strictly :-

(1) Remove the barrel guide and access panel from the wheel well wall and the bolts attaching the Teleflex clamp block.

(2) Carefully remove the 1/16 in. dia. countersunk steel locking rivet, which secures the lock plunger of each cable to the inner screwed rod on the outboard end of the Teleflex inner cable, without enlarging the hole in the rod or plunger. This rivet will be found 0.125 in. inboard of the outboard end of the lock plunger. Gently unscrew, by hand, the lock plunger from the inner screwed rod.

(3) Remove the radius rod eye-bolt and the P clip attaching the Teleflex outer conduit at rib No. 3.

(4) Remove the 4 B. A. bolt from the wrapped box, slacken the 2 B. A. clamp bolt and disconnect the end of the Teleflex outer conduit. Then disengage the end of the inner cable from the locking block.

(5) Withdraw the Teleflex outer conduit through the access hole in the wheel well wall sufficiently to expose the inner cable.

(6) Gently move the radius rod assembly into the retracted position by hand, taking care not to jam the Teleflex cable at the wrapped box, and unscrew the cable by hand (clockwise rotation).

13. During re-assembly, the following points should be noted :-

(1) With the lock plunger still removed from each control, replace the Teleflex inner cable into its respective outer flexible cover, push the screwed rod on the end of the inner cable inside the rigid conduit portion of the control, and gently withdraw the inner cable from the inboard end of the flexible outer cover to a distance of about eighteen inches.

Note...

These inner cables MUST NOT be pulled out to the fullest extent, otherwise the rigid screwed rod will foul on the bent end of the outer cover and cause damage to the inner cable at the swaged connection when the inner cable is screwed into the wrapped box during a later operation. Feed the complete control (less the lock plunger) into the mainplane through the handhole in the wheel well wall and, along the route of the control, through the rib to the wrapped box.

(2) Raise the radius rod to its "undercarriage retracted" position, and screw the Teleflex inner cable (left-hand thread) into the wrapped box

by hand. It is most important that this is achieved quite freely, and under no circumstances may any force or tool be used. Lower the radius rod slightly, and screw in the Teleflex inner cable sufficiently to give 0.10 in. projection on the inboard side of the box when sprung into the locking hole.

(3) Lubricate the Teleflex inner cable with grease, and slide each outer flexible cover inboard along the inner cable to the wrapped box. After entering and aligning the ends of the outer covers in a downward direction, secure to the wrapped box with the existing 4 B. A. lock bolt.

(4) Screw the lock plunger on to the inner screwed rod in its original position, and lock with a new 1/16 in. dia. steel countersunk rivet. Care must be taken that the rivet head or tail does not protrude above the outside diameter of the lock plunger, or in any way prevent the free sliding of the plunger and barrel.

(5) Adjust the forward and after door lock controls by means of the adjuster situated at the clamp block, so that, when the undercarriage radius rod is in the fully retracted position, the plunger protrudes 0.35 in. from the outboard end of the barrel. After adjustments have been made, the lock-nuts must be fully tightened and locked.

(6) Operate the undercarriage

radius rod by hand to ensure free travel of the Teleflex door lock cables. The load, applied to the lower attachment of the radius rod to overcome the friction of the controls, should not exceed 10 lb. Re-connect the undercarriage radius rod and jack.

WARNING

Ensure that the undercarriage jack adjustment has not been altered during the above operations.

Main undercarriage leg fairing

14. Adjust the leg fairing as follows :-

(1) With the wheel door radius rods again disconnected, refit the leg fairing and tighten its leg straps securely.

(2) Fully retract the undercarriage, and ensure that there is an all-round clearance of 0.050 in. to 0.150 in. between the periphery of the fairing and the edge of the main plane underskin and that the surfaces of both are flush; reposition the fairing about the leg and increase or decrease the number of packing washers on the strap attachment fittings as necessary.

(3) By manually closing the wheel door, check that a clearance of 0.050 in. to 0.200 in. exists between the butting edges of the wheel door and the fairing proper. The fairing shroud will of course overlap the inside of the door.

(4) Lower the undercarriage (WARNING preceding para. 7), completely deflate and fully compress the leg, and check that the torque links do not foul the leg fairing.

(5) Adjust the torque link micro switch (fig. 6) on the port leg, and the selector lever lock micro switch bracketed to the 1st pilot's engine control box, in accordance with the instructions in Sect. 5, Chap. 1. Reconnect the wheel door radius rods and re-inflate the leg. (Sect. 2, Chap. 2).

Nose undercarriage adjustment

15. The procedure for adjusting the radius rod and hydraulic jack of the nose undercarriage retraction mechanism is identical to that of the main undercarriage, except that, since the jack operates in the reverse direction, the adjustment to obtain the 1/16 in. to 3/32 in. lock plate roller to kidney slot clearance is made when the leg is in the fully down position. The amount of nose wheel retraction is governed by the length of the radius rod link (fig. 9), the nominal pin-centre length of which is 7.4 in. This link should be adjusted so that, when the undercarriage is locked up, the wheel is fully retracted into the wheel well.

16. The three up micro switches in the roof of the well immediately above the leg, and the down micro switch on the port wall of the wheel well (fig. 9),

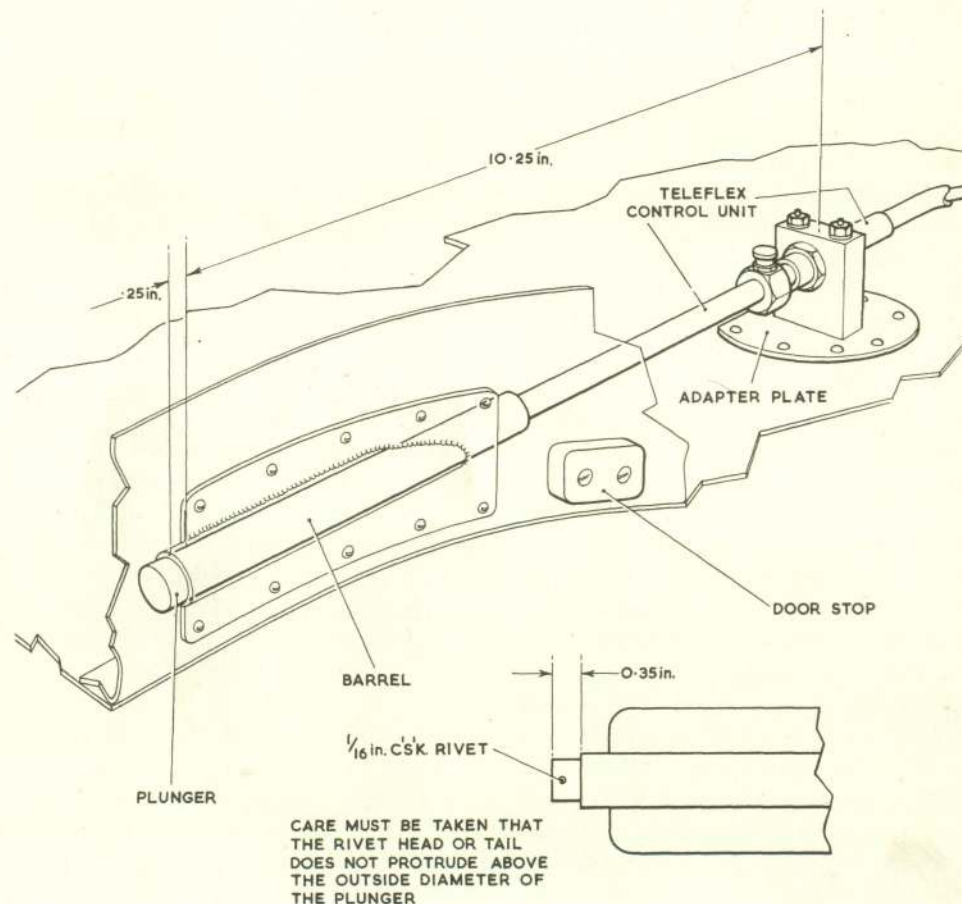

Fig. 5 Wheel door lock plunger

V/A0305-8/1

should now be adjusted in accordance with the instructions in Sect. 5, Chap. 1.

Nose undercarriage leg fairing and wheel door (fig. 7 and 9)

17. The hinged leg fairing and wheel door should be adjusted to lie flush with the gun blast tube fairings and nose fuselage skin, and to make firm contact with the fixed triangular fairing on the nose leg. Prior to carrying out nose wheel door adjustments, the following method of checking serviceability should be observed.

(1) With the undercarriage down, ensure that the nose wheel door guide striker plate is not bent, and that a flat does not exist covering the area of contact with the ball of the link guide assembly.

(2) Ensure that a 0.1in. clearance exists between the nose wheel striker plate and the air inflation valve when the nose shock absorber strut is collapsed.

(3) Check that the link guide attachment bracket mounted on the starboard side of the nose wheel wall, is not loose or distorted.

(4) By holding the ball of the guide link assembly, ensure that there is no undue fore and aft movement.

(5) Check that the lower radius rod eye bolt, is not bent.

(6) Where Modification Vampire 3236 is embodied, a clearance of 0.01in. to 0.015in. should be maintained between the slotted end of the operating rod and the lever on the nose wheel barrel, with the nose undercarriage in the fully down position. This is to prevent overloading, in the undercarriage down position, of the lever bearing spigot mounted on the starboard nose wheel wall.

18. The nose wheel door should always be re-adjusted when replacing the following items :-

(1) Nose undercarriage leg.

(2) Nose undercarriage striker plate.

(3) Nose wheel door

(4) Lower radius rod eye bolt.

19. During the adjustment of the nose wheel door, it may be found necessary to relieve the nose wheel door front hinge, to prevent the lower radius rod fouling the hinge bracket during lowering and retracting operations, which will cause bending of the lower radius rod eye bolt.

20. The following action should be taken in cases where a foul exists :-

(1) When the lower radius rod foul the hinge flanges at its lock nut, the flanges should be radiused to give clearance.

(2) It may now be found that the lower radius rod fouls the top of the hinge slot; this must be relieved with a round file to give a clearance of 0.1in. minimum on its closest position. Avoid sharp changes of section and treat with an approved primer and finishing coat.

(3) On some aircraft there may be inadequate clearance between the door hinges and the port cannon blast fairing with the door fully open. In such cases it is permissible to relieve the cut-outs in the cannon blast fairing.

(4) It may also be found necessary to relieve the edge of the port nose wheel well side beam, to prevent the fouling of the lower radius rod at approximately its mid position when the door is being retracted or lowered. Clear the foul on the nose wheel well side beam with a round file to give a clearance of 0.025 in. minimum.

21. When adjustments have to be made to the nose wheel door mechanism, the following important procedure should be strictly adhered to, to prevent over-tensioning of the nose wheel door :-

(1) Disconnect the nose leg hinged fairing attachment struts from the compression leg support casting, and also remove the nose wheel door lower radius rod attachment pin.

(2) Slowly retract the nose wheel undercarriage.

(3) Swing the nose wheel door into the closed position and hold there by hand pressure; adjust the lower radius rod adjustable eye-bolt until the pin can be fitted by hand.

(4) Lower the nose wheel door and remove the pin, and screw the eye-bolt in $1\frac{1}{2}$ turns to tension the door in the retracted position.

(5) Re-fit pin and split pin.

(6) Carry out nose wheel retraction tests.

Nose wheel door lock (Post Mod. 3572)

22. The procedure for setting the nose wheel door lock is as follows :-

(1) With the nose wheel door disconnected, raise the nose wheel by the hand pump, to the up position.

(2) Position the lay shaft to the up position, and adjust the cam on the lock plate assembly so that the cam ramp just contacts the roller surface.

(3) Reconnect the door mechanism and adjust the fork end of the connecting rod to give a 0.01in. clearance between the inside of the hook and the roller.

(4) Using the hand pump, lower the nose wheel to the down position and check that there is a minimum clearance of 0.10in. between the toe of the hook and the roller on the door bracket.

Charging and inflating the alighting gear shock-absorbers

23. As previously stated, instructions for the initial charging and inflation of the main and nose undercarriage shock-absorbers (when it will be necessary to jack the aircraft evenly clear of the ground) are contained in A. P. 1803C. To obviate the need for jacking for routine leg pressure checks however, suitable graphs giving inflation pressures in relation to aircraft loading will be found in Sect. 2, Chap. 2.

24. Whilst the main undercarriage units can be charged (and inflated) in situ, the nose undercarriage unit must be removed for charging purposes as detailed later in this chapter.

Retraction tests

25. The retraction tests for the alighting gear will be found in Chapter 6 of this Section.

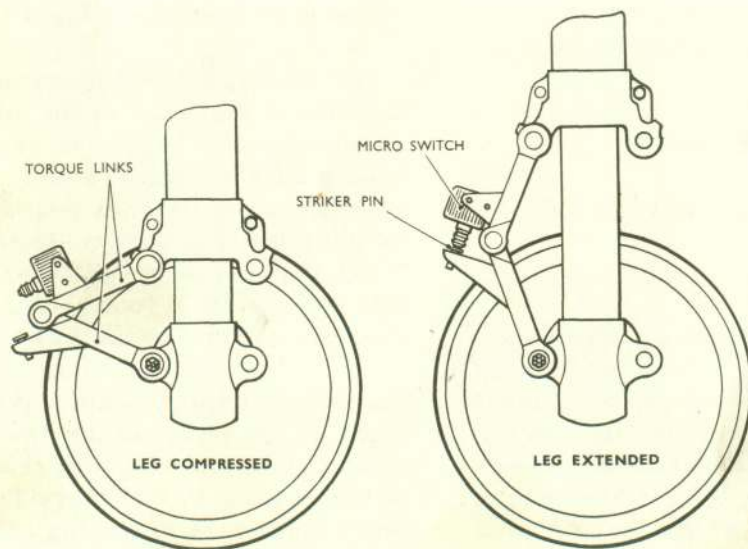

FIG. 6 TORQUE LINK MICRO SWITCH

RESTRICTED

VA0305-10/1

REMOVAL AND ASSEMBLY

General

26. The following paragraphs give an outline of the procedure to be adopted for the removal of the major lighting gear components from the aircraft. Except where instructions to the contrary are included, it may be assumed that re-assembly of those components entails only the reversal of the dismantling procedure.

Main wheel

27. To remove the main wheel :-

(1) Jack the aircraft evenly clear of the ground and release the brakes.

(2) Remove the split pin and wheel retaining nut and, using the special extractor, Pt. No. A3651, withdraw the wheel from the axle. If the wheel is not to be immediately replaced, the brake shoes should be suitably covered to protect them from contamination by grease and dirt.

WARNING

Under no circumstances must air pressure be admitted to the brakes whilst the wheels are removed.

Main undercarriage (fig. 8)

28. To remove the main undercarriage :-

(1) Jack the aircraft evenly clear of the ground, positioning the lifting jacks so that the leg can be swung in-

board as instructed in sub-para. (7) below.

(2) Release all hydraulic pressure from the main and emergency accumulators, and air pressure from the pneumatic system.

(3) Disconnect the pneumatic hose at the union at the top of the leg fairing, and, on the port undercarriage, detach the electrical leads from the torque link micro switch.

(4) Remove the main wheel, the leg fairing, the small detachable boom fairing on the undersurface of the wing just forward of the leg, and the access panel on the upper surface of the wing immediately above the leg.

(5) Dismantle the down micro switch from the wheel well recess.

(6) Disconnect the radius rod attachment eye-bolt from the pick-up casting on the leg.

(7) Remove the split pin and nut from the jack ram fork end attachment bolt, then swing the undercarriage inboard and withdraw the bolt from the ram fork end and undercarriage lever.

(8) With the leg suitably supported, release the four hinge fitting attachment bolts with the special ratchet spanners, Pt. No. YOO 185/6 (which are left- and right-handed respectively), and lower the leg.

29. Upon re-assembly of an undercarriage leg, shims of 24 s.w.g. cadmium-plated mild steel must be fitted as necessary to restrict the end-float to 0.005 in. to 0.030 in. The number of shims is limited to a maximum of three, and these should be fitted on either side of the leg attachment hinge points so that, if the radius rod is already fitted, the pick-up casting on the leg is equally disposed about the radius rod attachment eye-bolt when the leg is in the mid end float position. When fitting the main undercarriage jack top attachment bolt, ensure that the diametrical greasing hole is at right angles to the jack thrust line. The direction of this hole may be identified by a suitable marking on the bolt head.

Main undercarriage radius rod (fig. 8)

30. The radius rod may be removed from the aircraft independently of the undercarriage leg by adopting the following procedure :-

(1) Jack the aircraft evenly clear of the ground, positioning the lifting jacks so that the leg can be swung inboard as instructed in sub-para. (6).

(2) Release all air pressure from the pneumatic system, remove the main wheel, the leg fairing and the small detachable boom fairing on the undersurface of the wing just forward of the leg, and disconnect the wheel door radius rods.

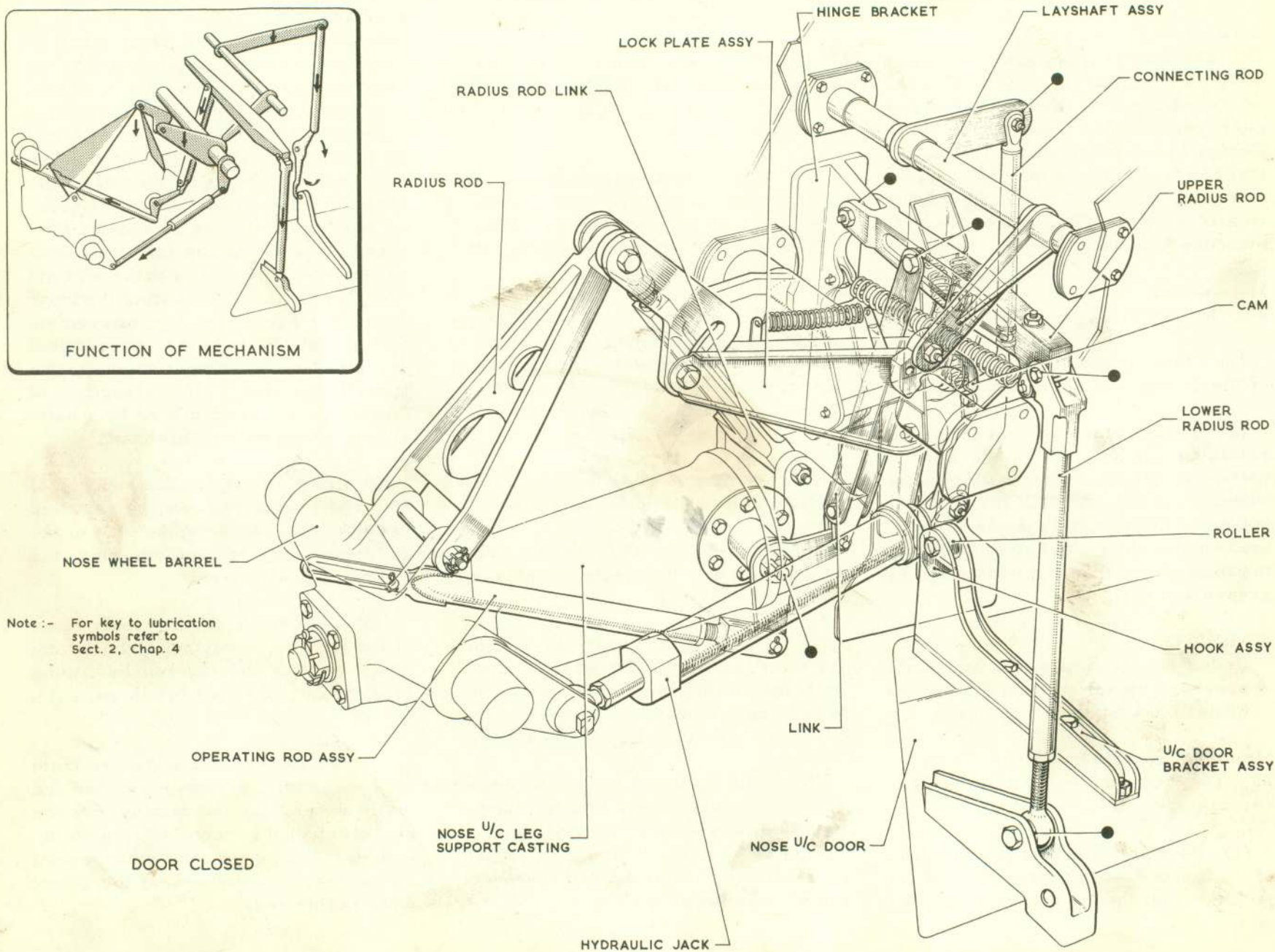
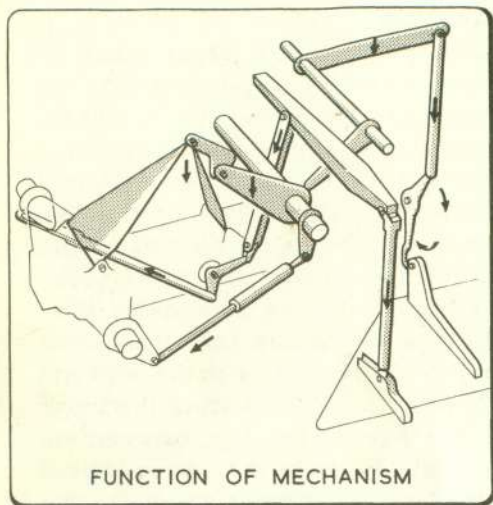

VA. 0305-12/1

Fig. 7 Nose wheel door mechanism

(3) Mark, with a vertical pencil line, the position of the exposed end of the plunger barrel guides on the adjacent wheel well wall, fully retract the undercarriage (WARNING preceding para. 7), and dismantle the barrel guides and, the plunger and slide tube assemblies.

(4) Lower the undercarriage fully (WARNING preceding para. 7), release all hydraulic pressure in the main and emergency accumulators, and disconnect the radius rod attachment eye-bolt from the pick-up casting on the leg.

(5) Dismantle the down micro switch from the wheel well recess.

(6) Remove the split pin and nut from the jack ram fork end attachment bolt, then swing the undercarriage inboard and withdraw the bolt from the ram fork end and undercarriage lever.

(7) Detach the bracket securing the pneumatic pipe union to the radius rod hinge block, and disconnect the union to allow the pipe to clear the radius rod when lowered.

(8) Disconnect the lock plate micro switch, release the two bolts from each hinge block, and lower the radius rod assembly complete, withdrawing, the Teleflex cables from their conduits. The bolt securing the jack to the jack lever on the radius rod is

most conveniently removed when the latter is clear of the wing recess.

31. Upon re-assembly of the radius rod, the following checks and precautions must be observed :-

(1) On re-connecting the body of the jack to the jack lever on the radius rod assembly, ensure that the thin castellated nut nips the washer against the shoulder of the special bolt, that all its threads are engaged in the normal manner and that it is not over-tightened.

(2) If difficulty is experienced in fitting the radius rod attachment bolts, the lock bolts securing the hinge blocks to the radius rod shaft must be slackened and the attachment bolts refitted and tightened without effort. The lock bolts must then be re-tightened, the radius rod assembly dismantled again and the bolts punch locked, when the radius rod may then be finally fitted.

Note...

If, in adopting the above procedure, difficulty is still experienced in fitting the radius rod attachment bolts after the lock bolts have been released, the mounting brackets must be renewed. Under no circumstances must tightness in the bracket threads be remedied by re-tapping.

(3) If the radius rod attachment eye-bolt does not line up centrally in

the fork of the pick-up casting on the leg, laminated brass shims, up to a maximum of 0.062 in., must be fitted between the one appropriate hinge block only and its mounting bracket to rectify this condition. In such circumstances, the amount of shimming necessary may be ascertained by grasping the eye-bolt and swinging the radius rod from side to side fore and aft, to determine its total end float. Shims should then be fitted as stated above so that, with the radius rod in the mid end float position, the centre-line of the eye-bolt coincides with that of the pick-up casting on the leg.

Note...

At no position of the undercarriage must the eye-bolt foul hard against the side of the pick-up casting.

(4) Ensure that the shims called for between the pick-up casting and its attachment lugs on the undercarriage leg (Mod. Vam. 812) are fitted between the forward faces of the leg and casting only.

(5) The door lock plunger assemblies must be re-assembled and rigged in accordance with the instructions in para. 12 and 13 as appropriate.

Teleflex cables, conduits and barrel guides.

32. The dismantling and reassembly of the Teleflex cables and conduits has been covered in paras. 12 and 13. Where new components are to be fitted,

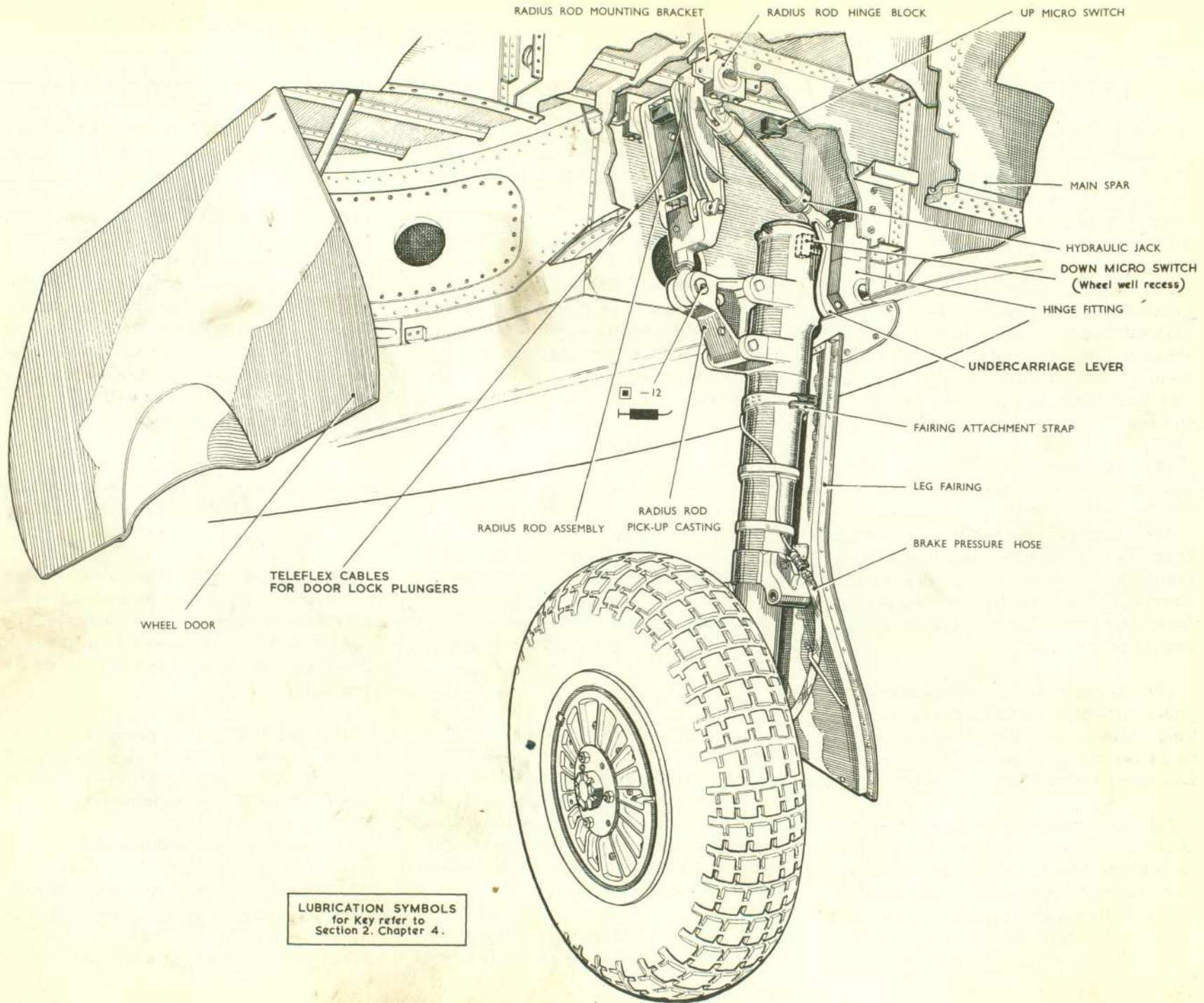

VA0305-14/1

Fig. 8 Main undercarriage

on assembly the following precautions must be observed :-

(1) Before installation of a new Teleflex cable, the ends must be well radiused, and all burrs and sharp edges removed.

(2) On installation of a new Teleflex conduit, it must be pushed fully home in the wrapped box on the radius rod assembly. The hole provided for the 4 B. A. clamp bolt which secures the conduit in the box, must be cleared with a No. 27 drill before the clamp bolt is fitted.

(3) Upon installation of a new Teleflex conduit, it must be pushed fully home in the wrapped box on the radius rod assembly. The hole provided for the 4 B. A. clamp bolt which secures the conduits in the box must then be cleared with a No. 27 drill before the clamp bolt is fitted.

WARNING

Failure to observe the foregoing installation precautions may lead to seizure or breakage of the door lock mechanism, possibly resulting in a wheel-up landing.

Nose wheel

33. Remove the nose wheel as follows :-

(1) Jack the aircraft so that the nose wheel is clear of the ground.

(2) Remove the tie-rod and end caps from the axle tube.

(3) Support the wheel, and carefully tap out the axle tube using a light alloy or similar drift.

Nose undercarriage unit (fig. 9)

34. Remove the nose undercarriage as follows :-

(1) Ensure that the main undercarriage ground locks are fitted, jack the aircraft so that the nose wheel is clear of the ground, and release all hydraulic pressure from the main and emergency accumulators.

(2) Detach the cover from the lower forward face of No. 1 bulkhead, and the false floor panel in the cabin immediately below each pair of rudder pedals, to afford access to the bolts and slotted nuts securing the undercarriage bearing tube attachment brackets.

(3) Remove the bolt securing the radius rod to the support link and radius rod link.

(4) Take out the special bolt securing the ram of the hydraulic jack to

the nose undercarriage lever via the hole provided in the port wall of the wheel well.

(5) Disconnect the wheel door linkage from the nose undercarriage.

(6) Support the undercarriage and remove the six split pins, nuts and bolts securing each bearing tube bracket to No. 1 bulkhead, then lower the entire assembly taking care not to damage the surrounding components.

35. Subsequent to the re-assembly of the nose undercarriage, it will be necessary to check the sealing of the bearing tube attachment bracket bolts by carrying out a leak rate test on the cabin in accordance with the instructions in Chap. 8, para. 7 (7).

Note...

When the nose undercarriage bearing tube is being refitted, it is important to eliminate end float by inserting shims of equal thickness between both ends of the bearing tube bushes and the attachment brackets to avoid the possibility of nose wheel shimmy. Ensure that the undercarriage swings freely and then clamp the attachment brackets.

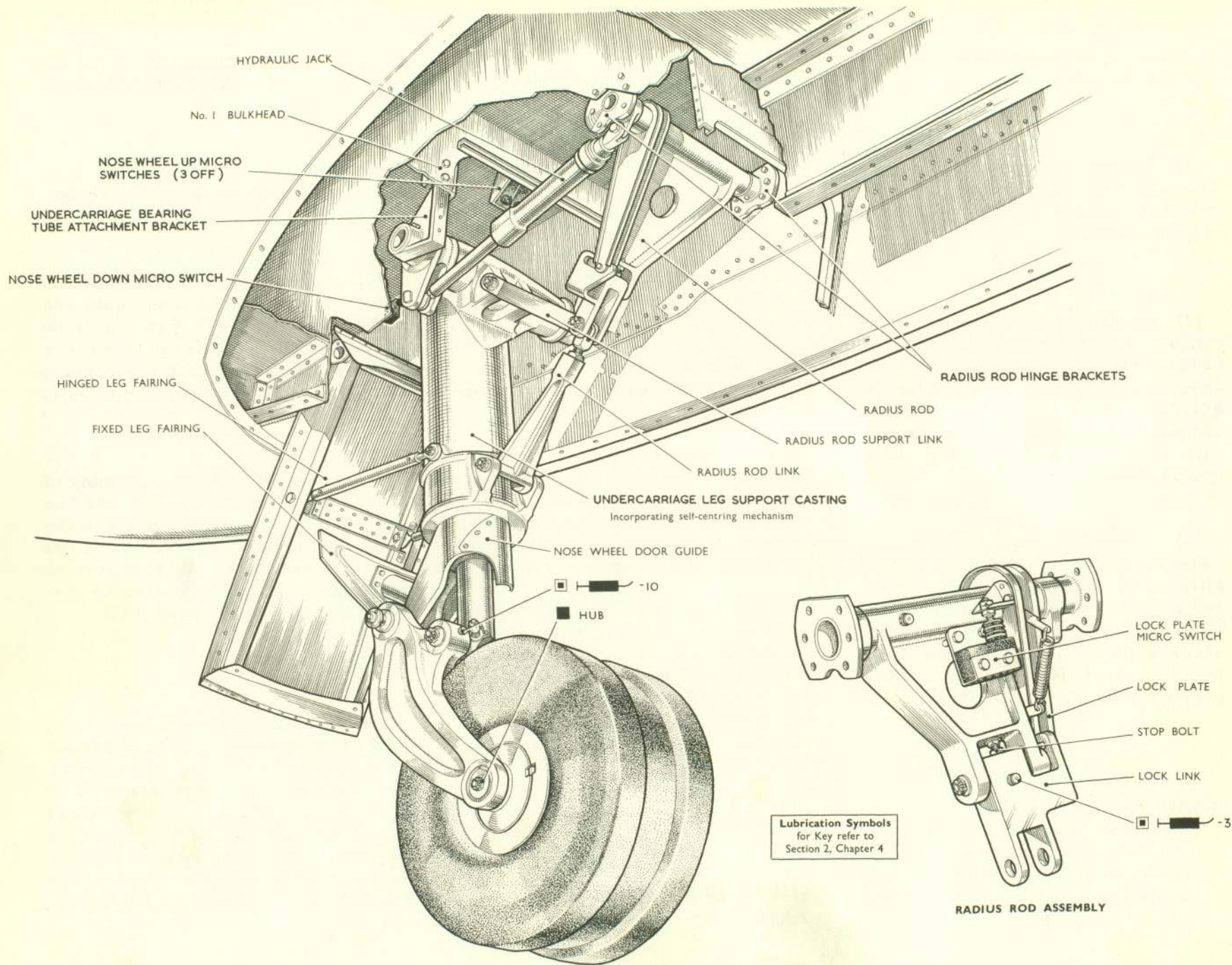

VMCUG-1671

Fig. 9 Nose undercarriage

Nose undercarriage radius rod
(fig. 9).

36. Remove the nose undercarriage radius rod as follows :-

(1) Ensure that the main undercarriage ground locks are fitted, jack the aircraft so that the nose wheel is clear of the ground and release all hydraulic pressure from the main and emergency accumulators.

(2) Remove the false floor panel in the cabin immediately below each pair of rudder pedals to gain access to the bolts securing the radius rod hinge brackets to the wheel well walls.

(3) Remove the bolt securing the radius rod to the support link and radius rod link.

(4) Take out the special bolt securing the ram of the hydraulic jack to the nose undercarriage lever via the hole provided in the port wall of the wheel well.

(5) Support the radius rod assembly, remove the six attachment bolts from each hinge bracket and lower the assembly, complete with the jack, clear of the wheel well; if necessary, the jack may now be detached from the radius rod without difficulty.

Self-centring mechanism

37. Having removed the nose wheel and the nose undercarriage unit as detailed in para. 33 and 34 respect-

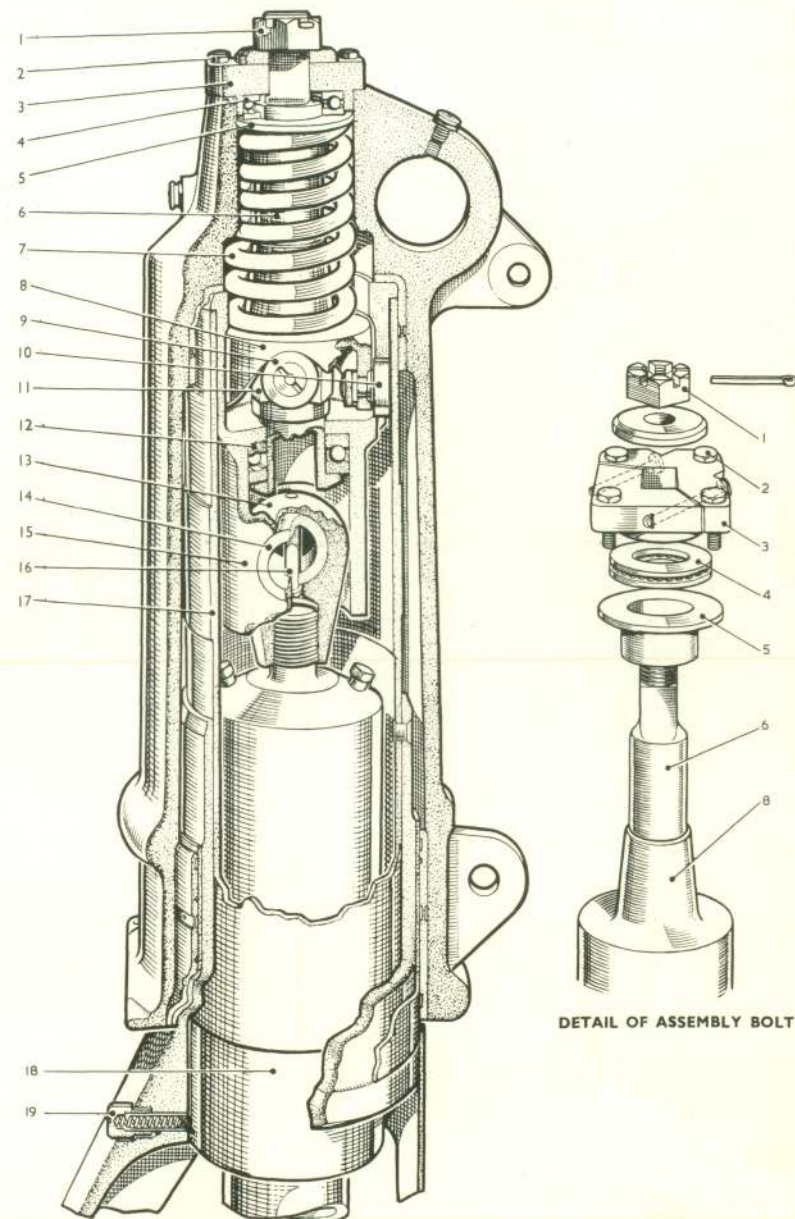

Fig. 10 Self-centring mechanism

RESTRICTED

ively, the procedure for dismantling the self-centring mechanism is as follows :-

(1) Extract the split pin and unscrew the slotted nut (1 in fig. 10), remove the four securing bolts (2), slacken the two 2 B. A. clamp bolts, and lift off the locating clamp (3), followed by the thrust bearing (4), spring collar (5), and spring (7). The swivel lug (17), complete with the shock-absorber (18) and the self-centring mechanism, may now be withdrawn from the outer casing.

(2) Unscrew the lock plunger (19), then, gripping the shock-absorber casting the inserting a lever in the pivot socket pin (17), unscrew the shock-absorber from the pivot socket (13) and withdraw it from the swivel lug.

(3) Unscrew the bolt (16), drive

out the pivot socket pin and separate the pivot socket from the self-centring mechanism.

(4) Remove the self centring cam (8) from the assembly bolt (6) and detach the slipper (10).

(5) Remove the two rollers (9) and the support collar (11), and withdraw the assembly bolt and the thrust race (12) from the thrust head (15).

38. Upon re-assembly of the locating clamp, it is essential that the three bolts securing the larger portion of the clamp are assembled first and the slotted nut tightened next to ensure a free fit on the assembly bolt. The slotted nut should then be released, the three bolts tightened evenly followed by the two 2 B. A. clamp bolts, when the slotted nut and all four securing bolts can be finally tightened and locked.

Nose undercarriage shock-absorber 39. The procedure for removing the nose undercarriage shock-absorber for charging or renewal purposes, is as follows :-

(1) Ensure that the main undercarriage ground locks are fitted, jack up the aircraft so that the nose wheel is clear of the ground, and release all hydraulic pressure from the main and emergency accumulators.

(2) Remove the nose wheel as instructed in para. 33.

(3) Disconnect the nose undercarriage forked link from the base of the shock-absorber.

(4) Unscrew the lock plunger from the swivel lug and shock-absorber from the pivot socket. Withdraw the shock-absorber from the swivel lug.

This file was downloaded
from the RTFM Library:

Link: www.scottbouch.com/rtfm

Please see site for usage terms,
and more aircraft documents.

