

Chapter 3 GUNS

LIST OF CONTENTS

DESCRIPTION	Para.	DESCRIPTION	Para.
General	1	Gun heating	15
Front mountings	2	SERVICING	
Rear mountings	3	Access to guns	16
Ammunition tanks	4	Servicing creeper	17
Ammunition feed	6	Harmonization	18
Ejection	7	Arming	19
Firing mechanism	8	Re-arming	21
Cocking	9	Butt tests	23
Blast tubes	10	REMOVAL AND ASSEMBLY	
Magazine carrier tie-rods	11	Sear release units	24
Gun sights	12	Guns	25
Gun sight recorder	13	G.G.S. retraction unit	26
Ciné camera	14		

LIST OF ILLUSTRATIONS

DESCRIPTION	Fig.
Gun mountings	1
Ammunition tanks and feed	2
Gun bay doors and nose fairing	3
Servicing creeper	4
Gun installation	5

DESCRIPTION

General

1. This Chapter covers the installation of two Hispano 20 m.m., Mk.5, No. 2 guns, together with instructions for re-arming, harmonizing and butt testing. Only the two inboard guns are normally installed, but four guns may be installed under the condition laid down in Sect. 2, Chap. 3. Details of the guns and their components are contained in A.P.(N)1024. The guns are positioned on the underside of the fuselage

in a heated gun bay, the outboard guns, when fitted, being situated approximately 9½ in. aft of the inboard guns (*fig. 5*). Details of the G.45 camera gun which is mounted in the fuselage nose and the G.G.S. camera recorder, are contained in A.P.1335D and A.P.(N)1024.

Front mountings (*fig. 1*)

2. The front mountings are of the ball and socket type comprising an inner and outer

eccentric, which provide both lateral and vertical alignment of the guns. The outer ball eccentric has 24 equally spaced grooves around the periphery, which run fore-and-aft in relation to the gun. One of these grooves engages the locking screw in the ball housing, when the gun is in correct alignment. The inner eccentric piston sleeve, which has a similar number of equally spaced grooves, may be locked to the outer eccentric by a spring-loaded locking tab. The procedure for aligning the guns is described in para. 18.

RESTRICTED

Rear mountings (fig. 1)

3. Each rear mounting consists of an inverted 'U' shaped bracket, which is hinged at its apex to a fitting on the roof of the gun bay. The mounting is capable of free reciprocal movement when recoil takes place. The spring-loaded plungers which engage in the mounting, must be wire-locked in their extended position when the gun is installed. Attached to each rear mounting is the gun lowering lanyard, which operates the B.F.M. (belt feed mechanism) release catch when the gun is lowered.

Ammunition tanks (fig. 2)

4. Two ammunition tanks are mounted above the guns between No. 2 and 3 bulkheads. Each tank is partitioned to form a forward compartment for the inboard gun and a rear compartment for the outboard gun. Each compartment will hold approximately 150 rounds of ammunition. The ammunition belt is fed over rollers at the top of each compartment and thence down vertical chutes to the B.F.M.

5. An ammunition loading diagram is positioned at the bottom of each compartment. Access for loading is gained through the hinged doors in the port and starboard side of the fuselage immediately aft of No. 2 bulkhead. The doors are supported in the open position by a hinged strut. The ammunition is retained in the boxes by tubular frames incorporating quick-release catches.

Ammunition feed

6. After passing over the rollers at the top of each ammunition compartment, the belt is fed down an integral vertical chute and thence through detachable chutes which curve through approximately 180 deg. before entering the B.F.M. on each gun. It will be seen that each detachable chute incorporates a hinged flap, through which the belts may be made or broken as required during re-arming.

Ejection

7. The empty case ejection chutes in the gun bay doors (fig. 3), are aligned with the ejector

openings on the guns. Separate ejector chutes for the links are adjacent to the empty case chutes.

Firing mechanism

8. The guns are fired by two switches mounted one on each control column (Sect. 1).

The safety catches incorporate an electrical fire-and-safe switch. The Maxiflux electric firing unit is screwed and wire-locked to the gun. The sear release unit, including the operating coils, is secured to the firing unit by a quick-release device operated by a knurled-headed screw (para. 24).

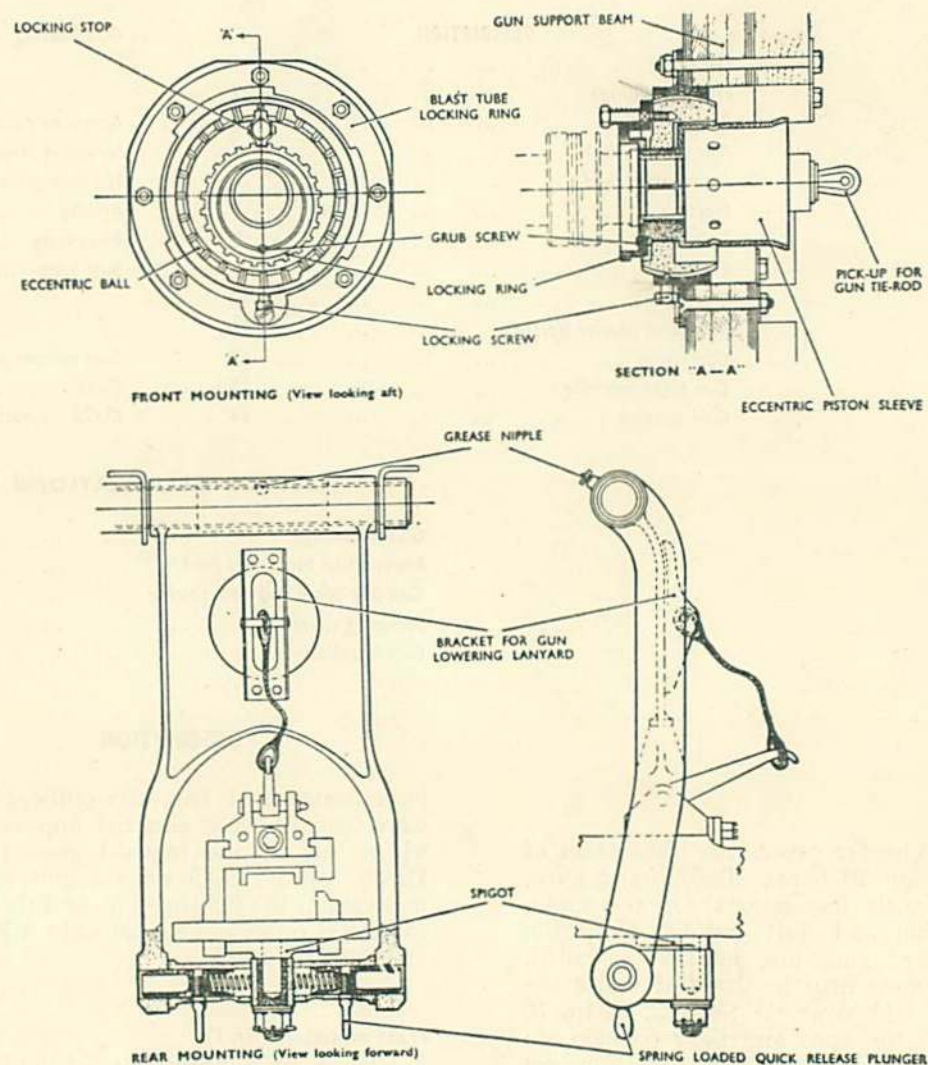

Fig. 1. Gun mountings

RESTRICTED

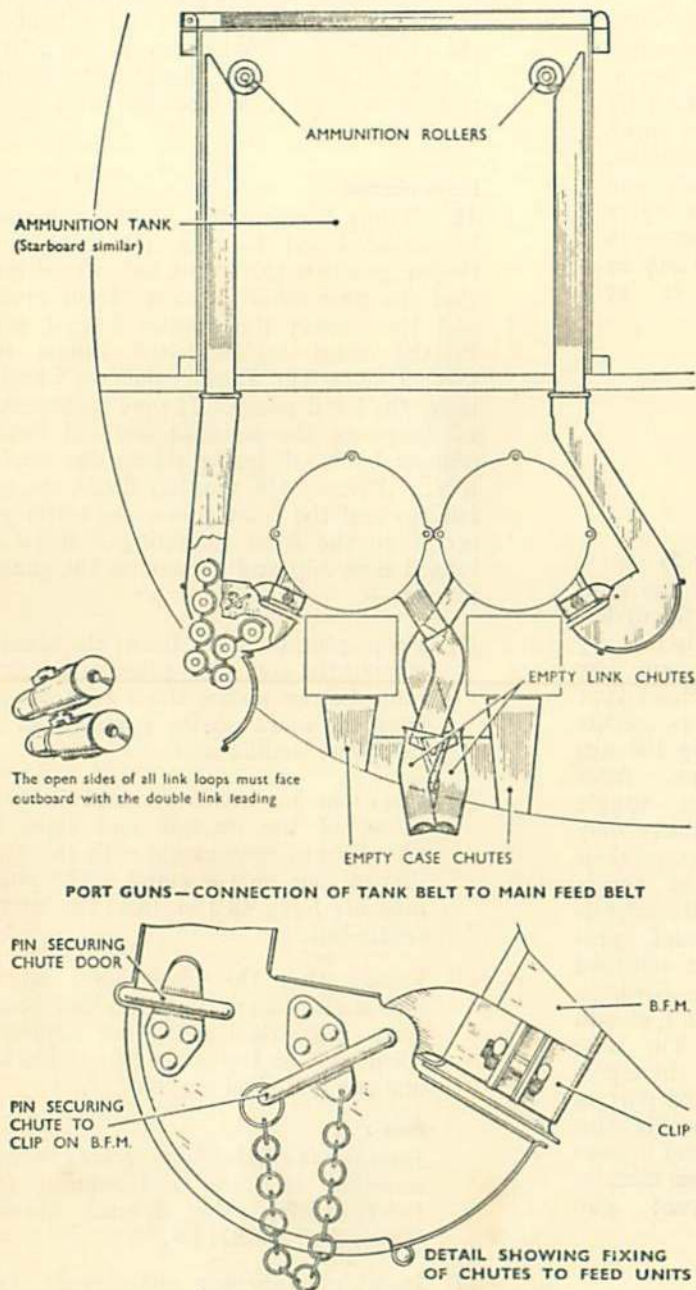

Fig. 2. Ammunition tanks and feed

Cocking

9. The guns are cocked with a No. 11 hand-cocking unit and details of its application will be found in A.P.(N)1025. A canvas bag on the inside of the gun bay door (fig. 3), is provided for stowing the unit.

Blast tubes

10. The Martin Baker telescopic-type blast tubes (fig. 5), are fitted over the gun barrels between the front mountings and the spout fairings. The tubes are secured to the front mountings by worm-type clips, the forward telescopic portions being held against the spout fairings by springs.

Magazine carrier tie-rods

11. The purpose of the tie-rods is to maintain the B.F.M. in a rigid position during the recoil of the guns. One end of the rod is attached to the slide into which the B.F.M. is clipped and the forward end is attached to an eye-bolt on the gun beam. The tie-rods have a $\frac{3}{8}$ in. adjustment and are located on the outboard side of each gun.

Gun sights

12. Two Mk.5 gyro gun sights for the 1st and 2nd pilots, are mounted below the front windscreen. Each gun sight is secured on a M.L. Aviation retraction unit, which allows each sight to be either retracted below the windscreen, or extended up to the 'alert' position. A twist grip on each throttle lever incorporates a Type T.I., Mk.1, control unit (Stores Ref. 8B/2979), which electrically operates the range control. Details of the gun sight are given in A.P. 1275E, Vol. 1.

Gun sight recorder

13. A mounting bracket is provided on the first pilot's gun sight for a G.G.S. camera recorder. A description of this camera is contained in A.P.(N)1024.

Cine-camera

14. A type G.45 cine-camera is mounted under the hinged nose cap (in which a glass panel is provided), on a type 27 mounting. An exposure switch and control unit is located on the lower right-hand cockpit wall. The camera is electrically-operated, and records automatically when the guns are fired. A separate switch is provided on the control column to permit the camera to be operated independently of the guns. Refer to A.P.1355D, Vol. 1 and A.P.(N)1024, for a description of the camera and its associated components and to para. 18 of this chapter, for the method of harmonising with the guns and the gun sight.

Gun heating

15. The gun bay is heated with warm air derived from the heater muff around the engine jet pipe. Air is ducted from an air-inlet in the starboard wing to the heater muff and back along the starboard side of the fuselage to the gun bay. The warm air is directed to the right- and left-hand guns through two distributor pipes. The pipes are secured to the airframe and do not interfere with the installation or removal of the guns.

RESTRICTED

SERVICING

WARNING

There is no fire-and-safe mechanism on the guns other than the firing switch safety catch and the nose wheel micro switch. The only master switch is the GROUND/FLIGHT switch, which controls the entire aircraft electric system. It is essential, therefore, to disconnect the electric lead plugs from the Maxiflux firing units, before attending to the armament installation in any way. The firing units should only be connected when the aircraft is 'at readiness.'

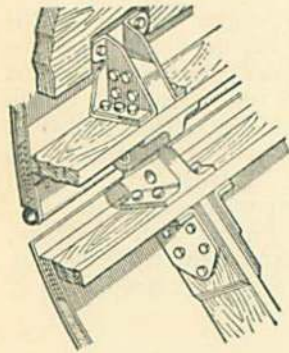

TYPICAL HINGE
(Showing attachment to fuselage side)

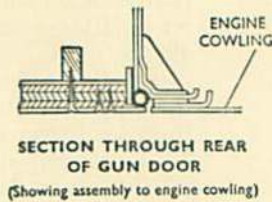

SECTION THROUGH REAR
OF GUN DOOR
(Showing assembly to engine cowling)

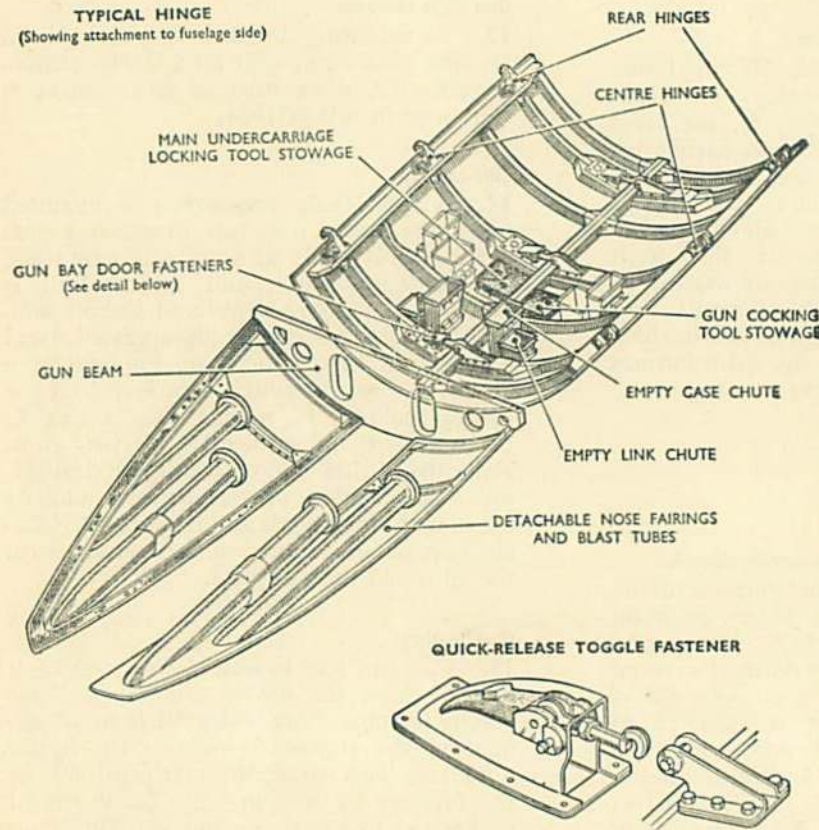

Fig. 3. Gun bay doors and nose fairing

Access to guns (fig. 3)

16. Access to the guns is gained from the underside of the aircraft by removing the gun bay doors. Three hook-type toggle fasteners secure the doors along the aircraft centre-line. After releasing the toggle fasteners the doors may be unhooked from their hinges. If the toggle fasteners require adjustment, the same procedure as that outlined for the engine cowlings in Sect. 4, Chap. 1, should be adopted. The nose fairing, which incorporates the forward part of the blast tubes is also detachable and gives access to the gun muzzles and the front gun mountings.

Servicing creeper

17. The servicing creeper shown in fig. 4 is recommended for gun servicing. The re-arming operations which call for the use of the creeper are annotated with an asterisk in para. 20, 22 and 25. The detachable head rest cover should be changed at frequent intervals.

Harmonization

18. Before harmonizing, all the guns must be unloaded and the aircraft trestled in the rigging position (Sect. 2, Chap. 4). Ensure that the nose wheel is clear of the ground and then insert the ground locking plugs in the main undercarriage radius rods (Sect. 2, Chap. 1). Retract the nose wheel by using the hand pump. It may be necessary to disengage the solenoid-operated locking plunger by hand, before raising the selector lever. Remove the gun bay doors, the nose fairings and the blast tubes, the latter give access to the front mountings. Raise the hinged nose cap and harmonize the guns as follows:—

- (1) Drop plumb lines from the leading edge of the port main plane at the mark immediately above the air-intake and from the mark on the port side of the tail plane leading edge.
- (2) Place the harmonizing stand 50 yards ahead of the aircraft and sight the plumb lines to coincide with the outer vertical line on the stand. The plumb lines are hung 48-0 in. from the aircraft centre-line.
- (3) Ensure that the spirit level on the lateral and longitudinal levelling boards reads zero, then place the adjustable spirit level on top of the breech block of one gun and level the gun.

Note . . .

Levelling is effected by unlocking the front mounting eccentrics and rotating them independently using special spanners (Stores Ref. 8D/2714-5).

- (4) Insert gun aligning instruments, Type C (Stores Ref. 1E/5157), fitted with

RESTRICTED

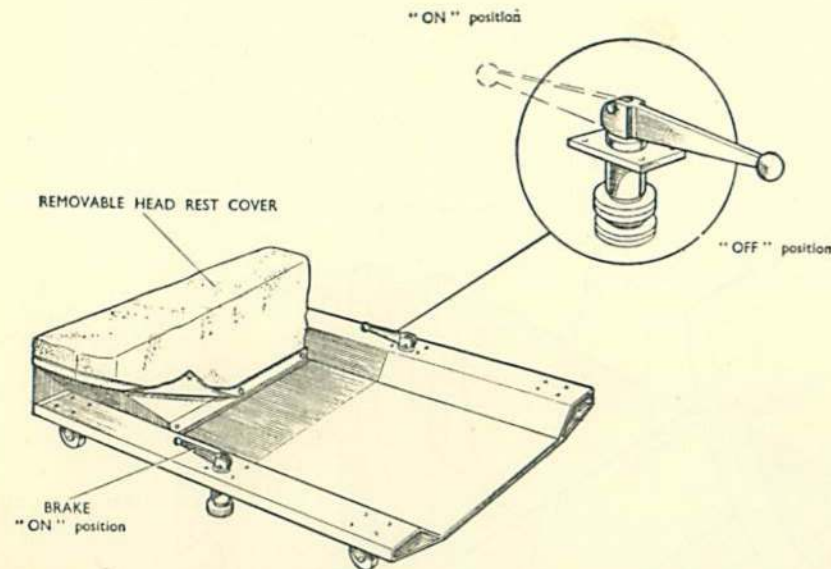

Fig. 4. Servicing creeper

adapter for 20 m.m. guns (Stores Ref. 1E/5206) in the gun barrel and sight on the harmonizing stand.

- (5) Adjust the stand cross bar, until the horizontal sighting line crosses the centre of the sight. Secure the bar in this position after ensuring that the horizontal line is level. The harmonizing stand is now in the correct position relative to the aircraft.
- (6) Adjust the gun until it is correctly aligned on its respective mark on the stand by rotating the front mounting eccentrics, then relock the eccentrics.
- (7) Align the second gun in turn on its respective mark on the stand and lock the front mounting eccentric. Recheck the alignment when the mountings are locked.
- (8) Align the gun sight on its respective mark on the harmonizing stand. A.P. 1275E, Vol. 1, gives the procedure for adjusting the sight. Lock all adjustments and recheck the harmonization.

- (9) Align the ciné camera with its sight mark on the harmonization stand. The method of using the sighting unit is described in A.P.1355D, Vol. 1.
- (10) Refit the blast tubes and the blast tube fairings and lower the nose cap.
- (11) Lower the nose wheel. Lower the aircraft to the ground and remove the trestles. Remove the ground locking plugs from the main under-carriage.

Arming

19. Instructions for loading the B.F.M.s are given in A.P.(N)1024.

Equipment

2 B.F.M.s (1 L.H. and 1 R.H.) fitted with appropriate feed and link chute extensions, loaded with 16 rounds and tensioned to 300 lb. in. Sufficient boxed ammunition in belts of 25 rounds.
 1 Servicing creeper (para. 17).
 1 Low platform or steps.
 1 No. 11 cocking unit.
 Cleaning equipment for chamber and barrel.
 Tools, breech stoppage, No. 2, Mk.1 (Stores Ref. 8D/2917).
 Feeler gauges.
 Screwdriver.

20. The procedure for arming is as follows and is to be read in conjunction with A.P.(N)1024, Appendix, Group 1.

- (1) Set the gun firing safety catch or flap, as applicable, to SAFE.
- (2) Open and remove the gun bay doors.

- * (3) Remove the plugs from the Maxiflux firing units.
- * (4) Remove the detachable feed chutes.
- * (5) Lower the guns on their lowering lanyards.
- (6) Open the ammunition tank access doors and remove the ammunition retaining frames. Fill the tanks as described on the ammunition loading diagram at the bottom of each compartment.
- * (7) Mount the filled B.F.M.s on the guns.
- * (8) Lift each gun in turn and lock it into position. Ensure that the quick-release locking plungers are fully engaged in the rear mounting stirrups.
- * (9) Replace the detachable feed chutes feeding the rounds from the B.F.M. through the open flaps.
- * (10) Join the belt from the ammunition tank to the belt from the B.F.M.
- * (11) Replace the plugs in the Maxiflux firing units *if the aircraft is 'at readiness.'*
- (12) Replace the ammunition tank retaining frames, close and secure the ammunition tank access doors.
- (13) Remove the servicing creeper.
- (14) Refit and secure the gun bay doors.
- (15) Fit gun muzzle covers.

Re-arming

21. The following equipment is required:—

Equipment

As for Arming (para. 19).

22. The procedure for re-arming is as follows:—

- (1) Set the gun firing safety catch or flap, as applicable, to SAFE.
- * (2) Open and remove the gun bay doors.

RESTRICTED

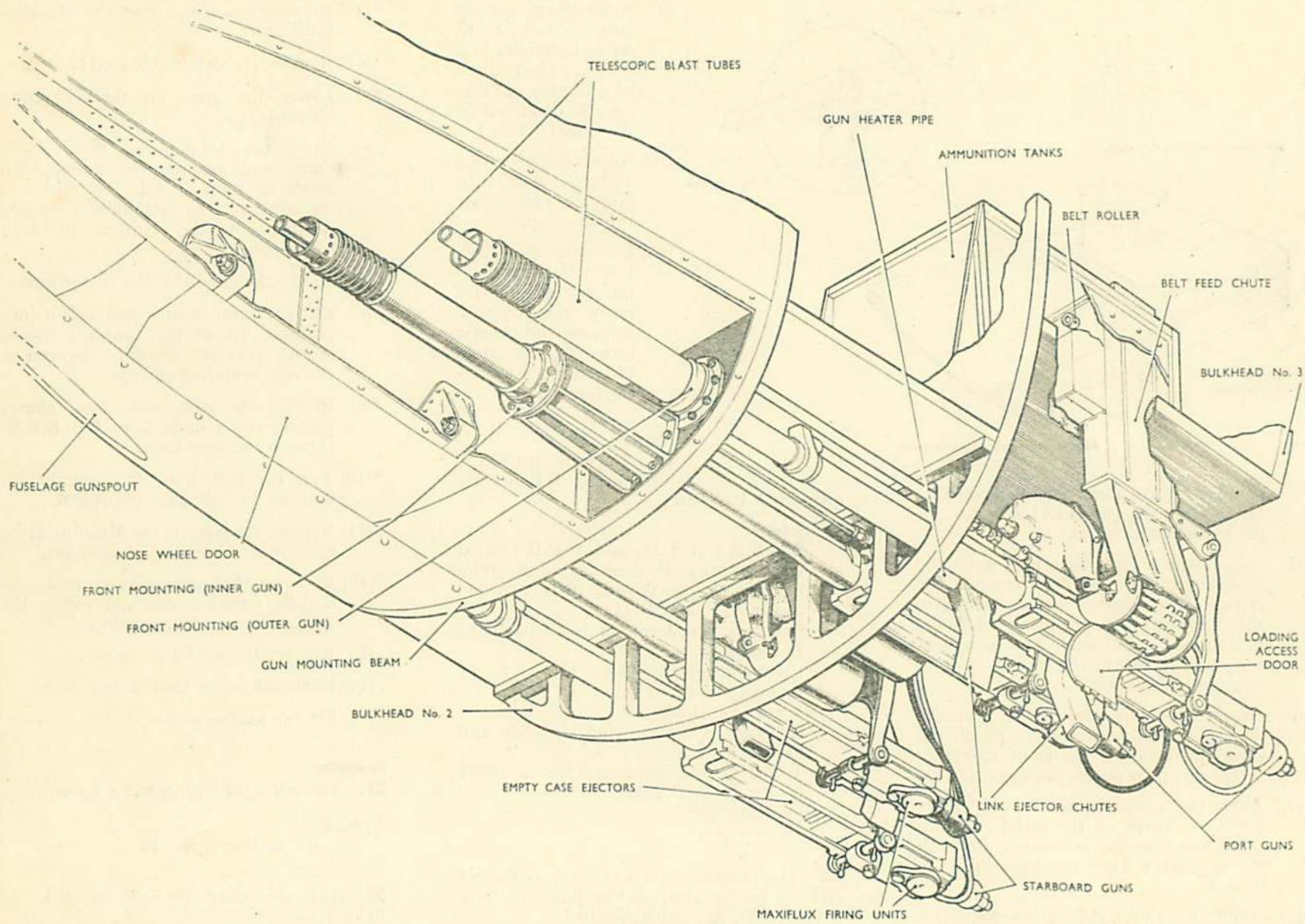

Fig. 5. Gun installation

RESTRICTED

- *(3) Remove the plugs from the Maxiflux firing units.
- *(4) Fit the breech stoppage tool (*para.* 19) to each gun and investigate any stoppages.
- (5) Open the ammunition tank access doors and remove the ammunition retaining frames.
- *(6) Open the flap in each detachable feed chute and break the belt if the

ammunition is not expended. Pull the remaining ammunition back into the tanks.

- *(7) Remove the detachable feed chutes.
- *(8) Lower the guns on their lowering lanyards and remove the B.F.M.s.
- (9) Remove any unexpended ammunition from the ammunition tanks.
- *(10) Carry out the "between flight servicing."

- *(11) Re-load the guns as detailed for Arming (*para.* 20 (6) to (15)).

Butt tests

23. When butt testing the guns, it is essential that the nose wheel is retracted and that the blast tubes and blast tube fairings are securely fitted. Failure to comply with these instructions will cause extensive damage to the forward structure of the fuselage.

WARNING

Fit the external locks in the main under-carriage radius rods before commencing work beneath the fuselage. All guns must be unloaded before any work is started.

Sear release units

24. The sear release units may be removed from the guns when the latter are installed. The procedure is as follows:—

- (1) Ensure that the breech block is in the fired position.
- (2) Release the gun back block catch and ease up the back block about $\frac{3}{16}$ in.
- (3) Support the weight of the sear release unit and unscrew the knurled-headed screw on the underside, until the unit has free vertical movement.

REMOVAL AND ASSEMBLY

- (4) Slide the sear release unit to the rear and downwards, out of engagement with the sear.

Guns

25. At the completion of the unloading operations, all the guns are cocked and suspended by their respective lowering lanyards. Commencing with the starboard gun the procedure for removal is as follows:—

- (1) Remove the blast tube by unscrewing the large worm-type clip which secures the blast tube to the front mounting.
- (2) Unscrew and remove the front mounting unit.
- *(3) Disconnect the B.F.M. carrier tie-rod by removing the nut and bolt between the rod and the extension.
- *(4) Support the gun, unhook the lowering

lanyard from the release catch and withdraw the gun to the rear.

The foregoing procedure should be repeated for the port gun.

The procedure for installing the guns is a reversal of that outlined above.

G.G.S. retraction unit

26. The procedure for removing the G.G.S. retraction unit is as follows:—

- (1) Remove the G.G.S. by unscrewing the mounting nut. Disconnect the electrical connections.
- (2) Remove the two bolts securing the unit to the lower mounting brackets.
- (3) Remove the two bolts securing the unit to the upper mounting brackets.

Assembly is a reversal of the above procedure.



This file was downloaded
from the RTFM Library.

Link: www.scottbouch.com/rtfm

Please see site for usage terms,
and more aircraft documents.