

Chapter I

PURPOSE, GENERAL DESCRIPTION AND OPERATING INSTRUCTIONS

LIST OF CONTENTS

	Para.		Para.
Purpose	1	Quick-release connections	14
General description	2	Manual over-ride instructions	15
Operating instructions	9	Safety precautions	16
Sequence of operations	10		

LIST OF ILLUSTRATIONS

	Fig.		Fig.
Mk. 3A ejection seat (structure)	1	Action of scissor shackle	5
Mk. 3A ejection seat (quick-release connections)... ..	2	Automatic operation—after ejection from aircraft (1)	6
Leg restraining device	3	Automatic operation—after ejection from aircraft (2)	7
Ejection procedure	4	Manual over-ride devices	8

Purpose

1. The Mk. 3A ejection seat (Stores Ref. 27L/50,008), shown in fig. 1 without emergency equipment and in fig. 2 fully equipped, enables the occupant to escape from an aircraft flying at high speed. The seat is ejected from the aircraft by means of a cartridge operated telescopic gun; fully automatic facilities are provided to separate the occupant from the seat and to open his parachute after ejection.

General description

2. The seat structure, complete with seat pan, slides during ejection on four rollers in a guide rail bolted to the aircraft structure. It is propelled by the ejection gun which is located within the hollow guide rail.

3. The ejection gun is fired by the action of pulling out a large horizontal handle, coloured red, immediately above the headrest pad. This handle draws out from the headrest a flexible screen which covers the occupant's face and protects it from the effects of the airstream. It also holds his head against the headrest pad and prevents it from jerking forward during ejection. A restraining device is incorporated to prevent the face screen from being sucked out of its compartment by the airstream. Attached to the screen is a cable which is connected to a sear in the firing body of the ejection gun. When the screen is pulled right down over the face, the cable withdraws the sear and the gun is fired. The face screen and firing cable are proportioned in such a manner that the ejection gun will be fired whether the occupant is wearing a protective helmet or not.

4. The seat pan accommodates a personal survival pack containing a dinghy, and can be adjusted for height by means of a hinged handle

on the starboard side of the seat structure. The seat pan moves relatively to the headrest and can thus accommodate different body lengths, at the same time ensuring that the occupant's head will always be correctly located on the headrest pad whatever the position of the seat pan.

5. A leg restraining device is incorporated (fig. 3), to ensure that the occupant's legs are drawn back automatically and restrained close to the seat pan with the knees approximately 6 in. apart. This provides leg clearance during ejection and also prevents injury from the legs being blown apart by the airstream after ejection.

6. A Mk. 9 back-type parachute assembly is carried and supported in a metal container hinged at its lower edge to the seat pan and attached at its upper edge to the seat frame by telescopic radius arms. A back pad and seat cushion are attached to the parachute harness, which also embodies two quick-release cords for the personal survival pack which is fitted outside the parachute harness. The object of this arrangement is to enable the escapee to free the personal survival pack during the parachute descent when he is nearing the ground. After the pack has been freed from the parachute harness, a 30 ft. length of nylon cord pulls free from the pockets into which it was stowed, and the descent is completed with the personal survival pack suspended 30 ft. below the escapee.

7. Type ZF safety harness is provided and has the two shoulder straps attached to the parachute container at the radius arms. The arms may be freed in flight by the movement of a lever projecting from the starboard side of the seat pan, thus permitting the occupant to lean forward when required. The arms can also be locked in intermediate positions.

RESTRICTED

RESTRICTED

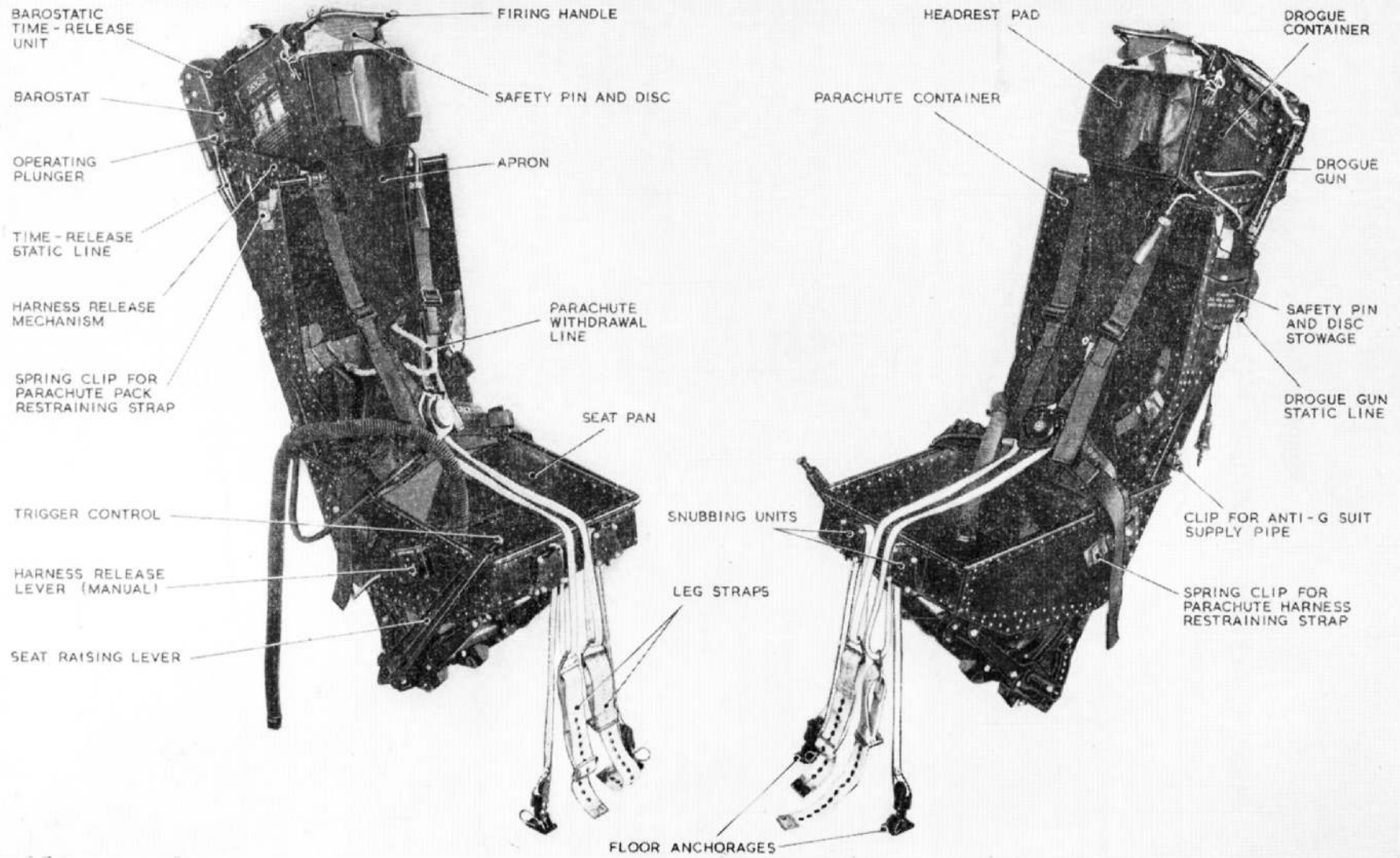

Fig. 1. Mk. 3A ejection seat (structure)

RESTRICTED



Fig. 2. Mk. 3A ejection seat (quick-release connections)

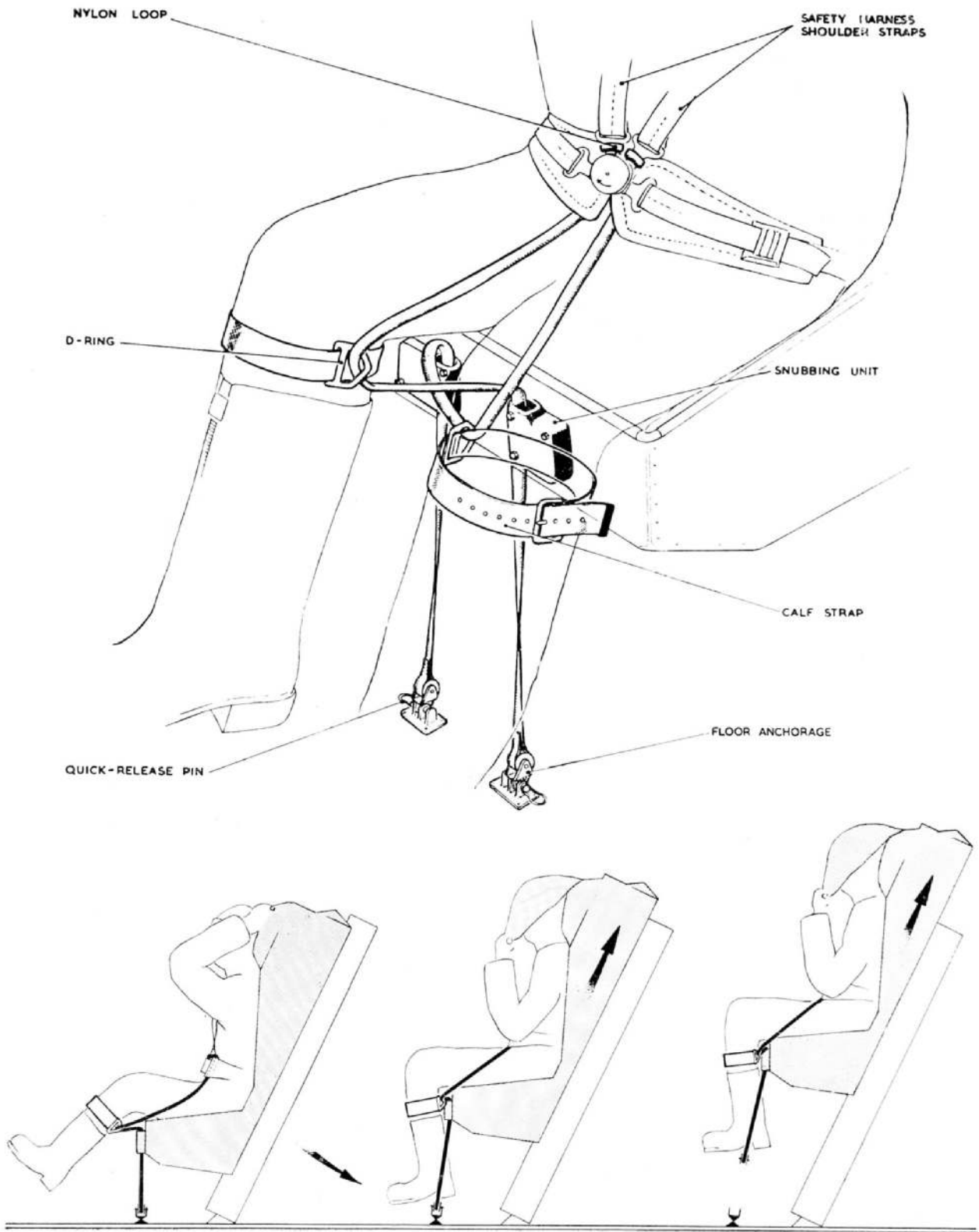

Fig. 3. Leg restraining device

RESTRICTED

ACTION 1

JETTISON THE COCKPIT CANOPY
ADJUST THE PARACHUTE CONTAINER
RIGHT BACK

ACTION 2

WITHDRAW THE FEET FROM THE RUDDER
PEDALS AND AT THE SAME TIME GRASP
THE FIRING HANDLE

ACTION 3

PULL THE FIRING HANDLE, WITH THE
FACE SCREEN, FIRMLY RIGHT DOWN
OVER THE FACE, KEEPING THE HEAD
HARD BACK AGAINST THE HEADREST



Fig. 4. Ejection procedure

RESTRICTED

drawal line is attached, is provided to pitch the occupant forward and open his parachute.

Operating instructions

9. The process of ejection from the aircraft is quite simple and straightforward and consists of three distinct actions (*fig. 4*) as follows:—

Action (1) Jettison the cockpit canopy. (There is no inter-connection between the jettison mechanism of the cockpit canopy and the gun firing mechanism, and therefore the canopy must be jettisoned before ejection takes place. It is advisable also, to ensure sufficient clearance during ejection, to lock the parachute container right back).

Action (2) Withdraw the feet from the rudder pedals and, at the same time, grasp the firing handle. (The movements of the feet and hands in this action should be made simultaneously. Both hands must grasp the firing handle firmly, with the knuckles facing forward and the elbows drawn close to the body. This ensures that the elbows will not contact the cockpit sides and that the chest will be protected against the airstream by the forearms).

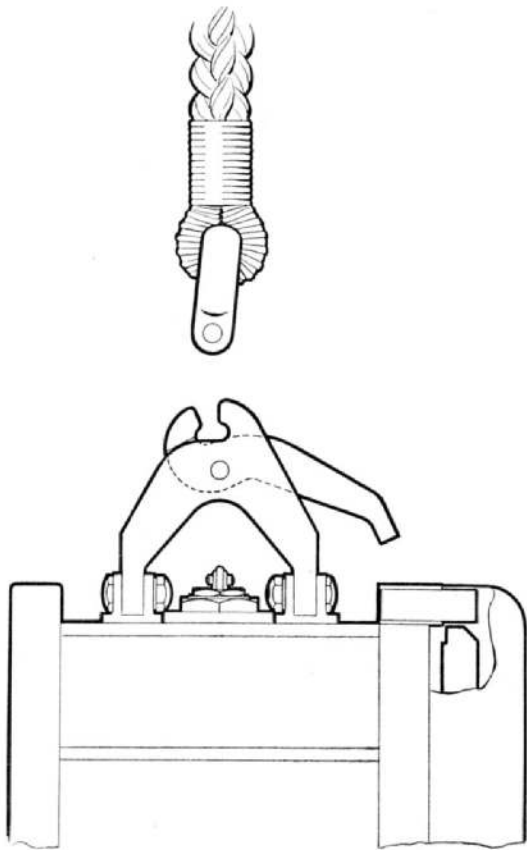
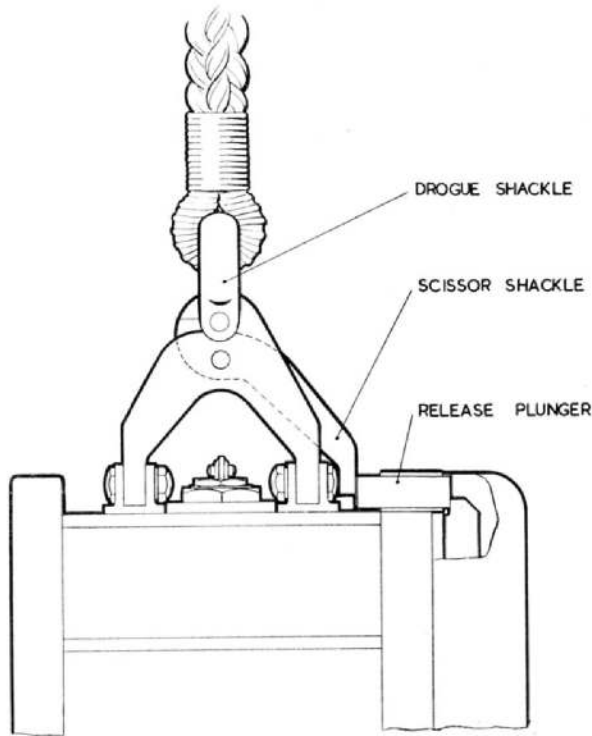

Fig. 5. Action of scissor shackle

8. The automatic system comprises a barostatic time-release unit, which controls the opening of a scissor shackle at the top of the seat structure and the operation of the safety harness quick-release fitting. An apron, to which the parachute with-



Fig. 6. Automatic operation—after ejection from aircraft (1)

RESTRICTED

Action (3) Pull the firing handle, with the face screen, firmly right down over the face, keeping the head hard back against the headrest pad. This action fires the gun and ejection occurs immediately. (As the firing of the cartridge is not affected by the speed of the movement, do not jerk the handle, or pull it outwards away from the face. The hands must be kept in close to the chest throughout the movement).

Sequence of operations

10. As the seat ascends the guide rail, two short static lines come into operation, one controlling the drogue gun time-delay mechanism and the other the barostatic time-release mechanism. After ~~0.5~~ ^{0.3} second's delay the drogue gun fires and extracts the drogue.

A/L. 30

11. For the purpose of description, it is assumed that ejection has taken place above 10,000 ft. The drogue first checks the forward speed of the seat and then stabilizes it in a slightly forward attitude.

12. At approximately 10,000 ft., the barostat removes an obstruction to a gear train which then commences to operate. After ~~two~~ ^{three} seconds delay, the safety harness is released, the scissor shackle opens (fig. 5) and releases the drogue lines. The resultant pull of the drogue withdraws the retaining pins, so releasing the face screen, firing handle and headrest pad. The apron pulls taut, pitches the occupant forward, and the withdrawal line attached to the apron withdraws the parachute from its pack (fig. 6 and 7). The development of the parachute finally pulls the occupant clear, thus allowing the seat to fall freely. This leaves the drogue, apron and lifting lines attached to the parachute.

A/L. 30

13. At any convenient altitude, soon after parachute development, the occupant pulls the quick-release cords to free the personal survival pack. This reduces oscillation and lessens the likelihood of injury occurring on impact with the ground.

Quick-release connections

14. When the seat is ejected, the aircraft oxygen and intercom. services disengage automatically at

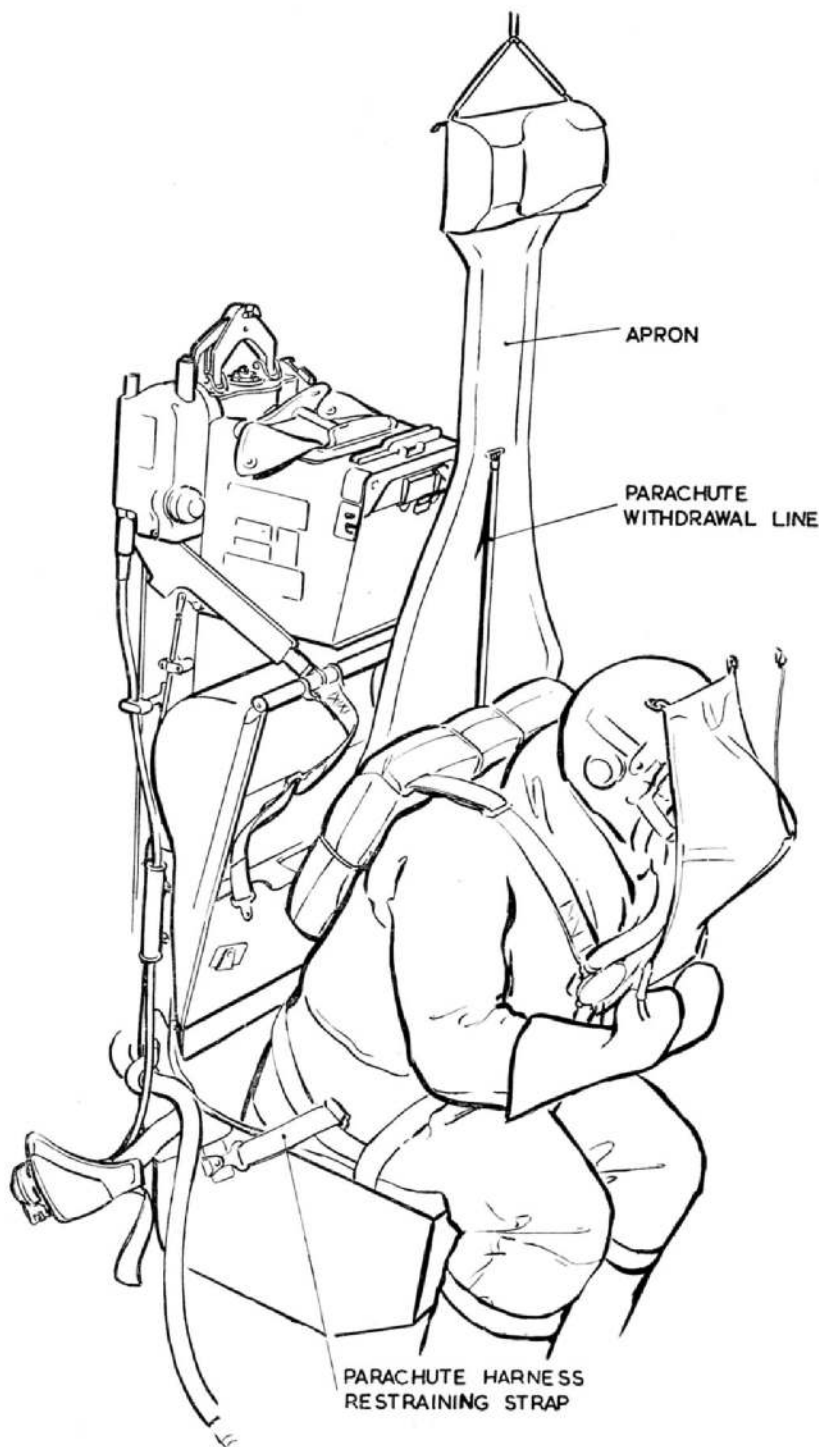

Fig. 7. Automatic operation—after ejection from aircraft (2)

the quick-release connections shown in fig. 2. Further quick-release connections are provided for disengaging these services when the occupant leaves the seat subsequent to ejection. Quick-release connections are also provided for the emergency oxygen system: one to operate the emergency oxygen bottle on ejection and then to disengage, and another to enable the oxygen mask to be disconnected from the oxygen bottle in the seat cushion. The latter action is not automatic.

(A.L.22, June 55)

RESTRICTED



SAFETY HARNESS
QUICK-RELEASE LEVER

MANUAL OVER-RIDE
D-RING



PARACHUTE RIP-CORD
D-RING

DINGHY PACK
RELEASE CORD

Fig. 8. Manual over-ride devices

RESTRICTED

Manual over-ride instructions

15. If, for any reason, the automatic system fails to function, proceed as follows:—

- (1) After the forward speed has been checked by the drogues, discard the firing handle and face screen and pull the over-ride D-ring (upper diagram, *fig. 8*). This isolates the automatic parachute opening device.
- (2) At a safe altitude, rotate the safety harness quick-release lever to the left to release the harness.
- (3) Lift the top flap as shown (lower diagram, *fig. 8*), push clear of the seat and pull the parachute rip cord to make a normal parachute descent.

IMPORTANT

It is vital to concentrate all the faculties on operating the manual over-ride and releasing the safety harness; the seat will probably be spinning and the occupant therefore confused.

Safety precautions

16. A fabric strap is attached to the front edge of the drogue container. When this strap is passed through the firing handle and locked by

the spring safety pin provided, the face screen is locked against the possibility of withdrawal. A warning disc is attached to the safety pin. Before flight, this pin must be withdrawn by the pilot and stowed, with the warning disc, in the stowage provided on the left-hand side of the parachute container. On leaving the aircraft, the pilot must replace the safety pin to lock the firing handle.

17. Before any work is done in the aircraft cockpit, the safety pin must be withdrawn from the face screen lock and inserted in the hole in the sear at the top of the ejection gun in accordance with A.M.O. A.284/50 as amended.

18. A rivet is fitted to the front portion of the firing sear to prevent it being pulled backwards and so firing the ejection gun.

19. Special guards are incorporated in the brackets to which the static lines are attached; their purpose is to prevent inadvertent operation of the drogue gun or barostatic time-release units by personnel moving between the pilots' seats on the flight deck of the aircraft.

This file was downloaded
from the RTFM Library.

Link: www.scottbouch.com/rtfm

Please see site for usage terms,
and more aircraft documents.

