

Chapter 5

SERVICING

LIST OF CONTENTS

	Para.		Para.
Special tools	1	To examine and assemble the parachute container radius arms	19
Removing the secondary cartridge	2	To dismantle the seat raising mechanism	20
Removing the primary cartridge	3	To examine the seat raising mechanism	21
Removing the drogue gun from the seat	4	To assemble the seat raising mechanism	22
Removing the seat from the aircraft	5	To fit the seat pan	23
Removing the ejection gun from the guide rail	6	Testing the lifting lines	24
Servicing the ejection gun		Fitting the lifting lines	25
To remove the piston tube from the cylinder tube	7	Servicing the barostatic time-release unit	26
To remove the release mechanism from the cylinder tube	8	To fit and re-set the time-release unit	27
To examine the release mechanism	9	Servicing the face screen and drogue	
To examine the firing mechanism	10	To test the face screen	28
To assemble the release mechanism in the cylinder tube	11	To examine the face screen	29
To assemble the piston tube in the cylinder tube	12	To pack the face screen	30
Servicing the drogue gun		To examine the drogues	31
To remove the drogue gun cartridge	13	To pack the drogues	32
To test the time-delay and firing mechanisms	14	Fitting the ejection gun in the guide rail	33
To re-set the time-delay mechanism	15	Installing the seat in the aircraft	34
To assemble the drogue gun	16	Fitting the drogue gun	35
Servicing the seat structure		Fitting the primary cartridge	36
To remove the seat pan	17	Fitting the secondary cartridge	37
To remove and dismantle the parachute container radius arms	18		

LIST OF ILLUSTRATIONS

	Fig.		Fig.
Special tools	1	Fitting piston ring clip	11
Disconnecting firing cable from sear	2	Pencil holder	12
Rendering the drogue gun safe	3	Method of setting up lathe... ..	13
Removing the drogue gun	4	Specimen graph	14
Top latch safety pin	5	Re-setting drogue gun time-delay mechanism	15
Removing cylinder head	6	Testing the lifting lines	16
Dismantling release piston... ..	7	Fitting the lifting lines	17
Lifting firing pin with special tool	8	Re-setting the barostatic time-release mechanism	18
Testing firing spring	9	Testing the face screen	19
Ejection gun components	10	Stowing the drogues	20

Special tools (fig. 1)

1. The following is a list of special tools required for servicing the ejection seat:—

Tool	Stores Ref. No.	Purpose
Combination spanner	27L/353	Access to primary and secondary cartridges
Pressers sealing pliers	1B/4122	Sealing locking wires securing primary, secondary and drogue gun cartridges.
Firing pin lifting tool	27L/98	Lifting firing pin of primary cartridge firing mechanism
Blocks, clamp	27L/91	Gripping cylinder tube in vice jaws
Spanner, release piston	27L/96	Restraining the release piston
Spanners, "C" (2 off)	27L/95	Removing and assembling cylinder head
Clips, piston ring	27L/92	Replacing piston tube in cylinder tube
Protrusion gauge	27L/186	Testing the firing pin protrusion of the primary and drogue gun firing units; testing the efficiency of the drogue gun cartridge retaining clip.
Harness release plunger tool	27L/271	Re-setting barostatic time-release unit
Rack plunger tool	27L/272	Re-setting barostatic time-release unit
Drogue gun cocking tool	27L/273	Re-setting drogue gun time-delay mechanism

(A.L.16, Oct., 55)

RESTRICTED

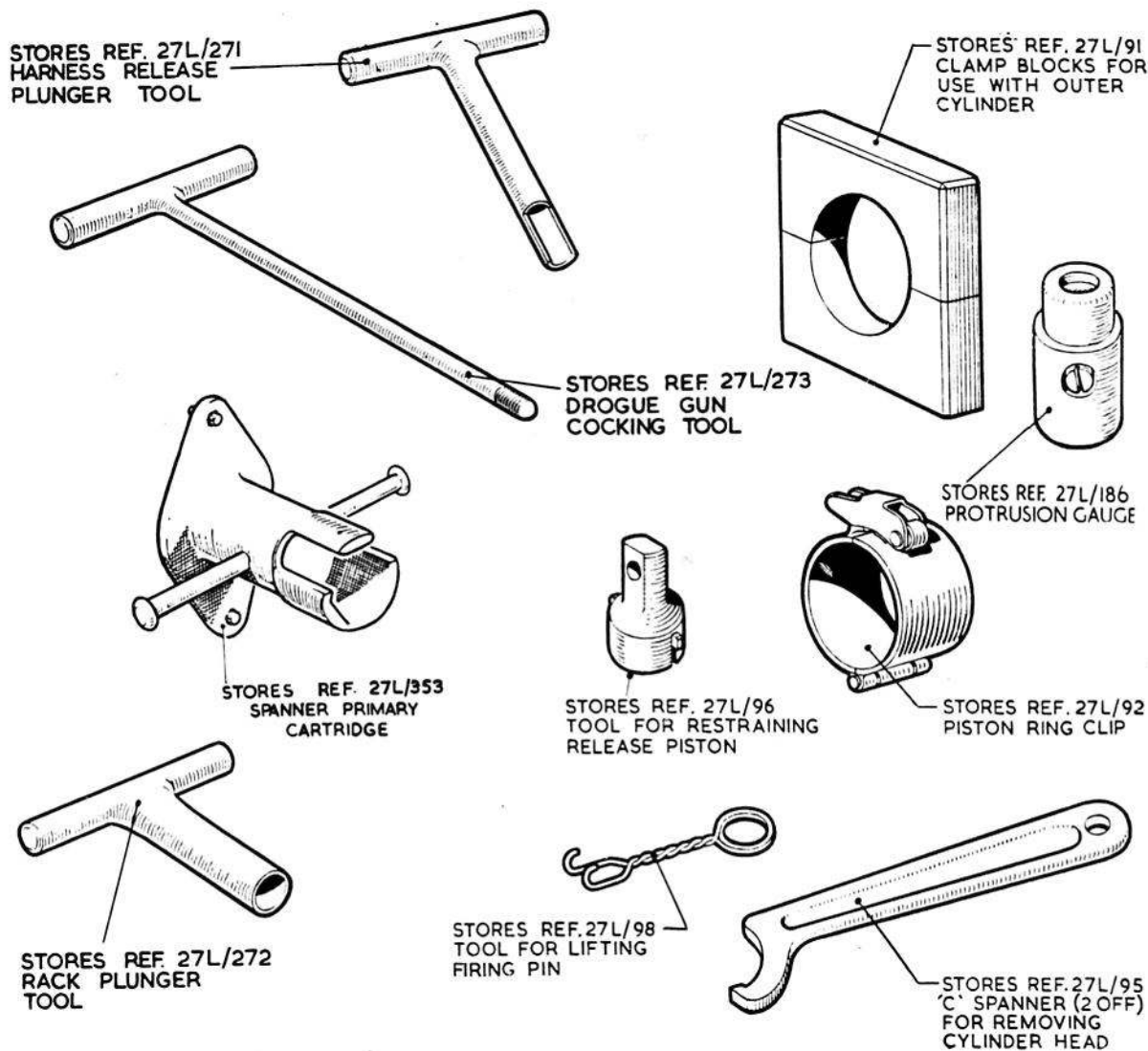

Fig. 1. Special tools

Removing the secondary cartridge

IMPORTANT

The secondary and primary cartridges and the drogue gun **MUST** be removed before the seat is lifted from the aircraft.

- 2.
- (1) Place the safety pin in the hole in the sear.
- (2) Depress the seat pan to its lowest position whilst sitting in it to counteract the load of the seat balance springs.
- (3) Slide up the cover plate in the back of the seat pan to expose the secondary cartridge cover.
- (4) Break the sealed locking wire and unscrew the secondary cartridge cover, using the special combination spanner provided.
- (5) Remove the secondary cartridge.

Removing the primary cartridge

3.

- (1) Ease the firing sear forward by hand (*fig. 2*), and disconnect the eye end of the firing cable; the sear will automatically slide back to its original position.

WARNING

In no circumstances must the sear be extracted while the cartridge is in position. Any attempt to do so will result in the cartridge being fired.

- (2) Break the sealed locking wire, then fit the special spanner. Lift the safety pin disc and engage the holes in the disc with the two pegs on top of the spanner.
- (3) Unscrew the firing body from the breach. The primary cartridge will be pushed upwards by a spring which should be removed with the cartridge; loosely replace the cartridge cover to exclude dust.

Removing the drogue gun from the seat

4.

- (1) Disconnect the static line by withdrawing the quick-release pin. Render the gun safe by inserting the pin in the safety lock (*fig. 3*).

RESTRICTED

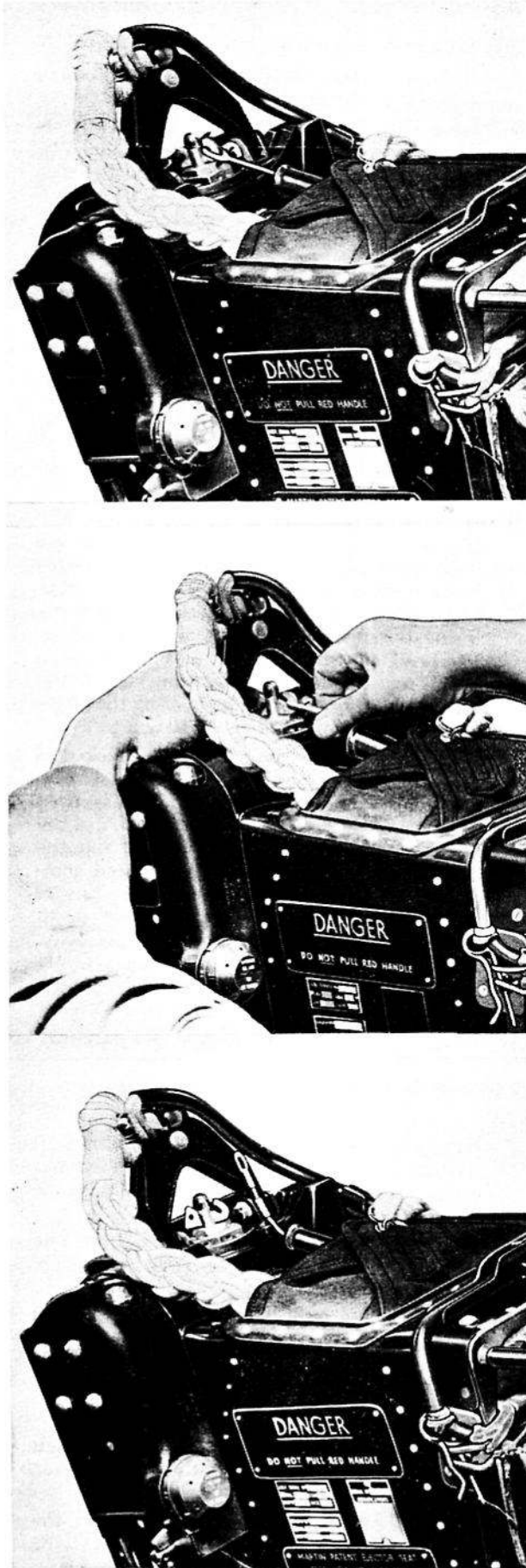

Fig. 2. Disconnecting firing cable from sear



Fig. 3. Drogue gun safety lock

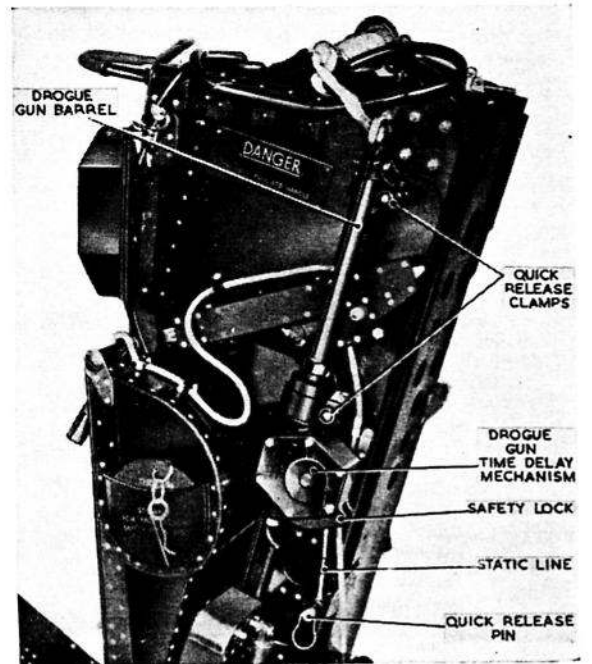

Fig. 4. Drogue gun assembly

RESTRICTED

- (2) Disconnect the drogue withdrawal line by pulling out the quick-release pin which attaches it to the drogue gun piston.
- (3) Operate the two quick-release clamps (*fig. 4*) and lift out the drogue gun.

Removing the seat from the aircraft

5.
 - (1) Remove the parachute and dinghy pack.
 - (2) Disconnect the intercom. lead and the main and emergency oxygen connections.
 - (3) Disconnect the barostatic time-release unit static line from the bracket on the guide rail.
 - (4) Withdraw the safety pin from its housing (*fig. 5*), release the top latch and lift the seat up the guide rail.

Removing the ejection gun from the guide rail

6. Draw out the bottom latch by the ring, turn the gun through 90 deg. to bring the secondary cartridge housing into the guide rail and lift out the gun, taking care not to damage the cylinder tube by allowing it to strike the walls of the guide rail or any part of the aircraft.

Servicing the ejection gun

To remove the piston tube from the cylinder tube

7. Pull out the release button to its fullest extent and draw the piston tube out of the cylinder tube, taking care not to damage the piston rings.

To remove the release mechanism from the cylinder tube

8.
 - (1) Grip the cylinder tube in the special clamp blocks (*fig. 6*), remove the locking wire and unscrew the cylinder head, using the special C-spanners provided. Do not remove the end cap from the cylinder tube.
 - (2) Remove the lock-nut in the release button with a $\frac{5}{16}$ in. B.S.F. box spanner, at the same time restraining the release piston from turning by engaging the special tool in the slots provided (*fig. 7*).
 - (3) Pull off the release button; the release piston and spring can then be withdrawn from the cylinder head.



Fig. 5. Top latch safety pin

To examine the release mechanism

9.
 - (1) Check that all parts are free from corrosion.
 - (2) Check that the locking tabs on the cylinder head are undamaged.
 - (3) Check that the release piston slides freely in the cylinder head and that the drain holes in the piston and cylinder head are clear.

To examine the firing mechanism

10.
 - (1) With the firing pin in the fired position, place the protrusion gauge in position in the firing unit. If the plunger is flush with, or above, the level of the body, the protrusion is correct.
 - (2) Remove the firing pin from the firing body. Using kerosine, wash any traces of grease from the firing pin and the interior of the firing body, then lightly lubricate with oil OM-13 (Stores Ref. ^{NS Part} E 9/422). Assemble the firing pin in the firing body. (AL 96)
 - (3) Lift the firing pin with the special tool (*fig. 8*) and check that the firing sear moves freely in the slot, and that the firing pin moves freely throughout its stroke. Remove the sear and check the initial compression of the firing spring by spring balance as shown in *fig. 9*. The firing pin should not start to move until 7 lb. is registered. The initial movement of the firing pin can be detected by holding the finger over the projecting end of the striker pin.
 - (4) If the action of the firing pin when checked as described in sub-para. (3) is unsatisfactory, the retaining nut (*fig. 10*) should be unscrewed with a $\frac{3}{8}$ in. box spanner, after the tab of the brass locking washer is bent down, and the firing pin assembly should be renewed complete with a new locking washer. Ensure that the locking washer tab already bent down engages the slot in the top of the firing body, and after the retaining nut has been firmly screwed down, one of the other tabs should be bent up to lock it.
 - (5) Repeat the checks described in sub-para. (3).

To assemble the release mechanism in the cylinder tube

11.
 - (1) Apply a coat of grease XG-275 (Stores Ref. 34B/222) and assemble the release piston and spring into the cylinder head, using the special spanner.
 - (2) With the piston tube withdrawn from the cylinder tube, screw the cylinder head back, using the special C-spanners.
 - (3) Lock with new 22 S.W.G. non-corrodible steel locking wire.

To assemble the piston tube in the cylinder tube

12.
 - (1) Check the piston rings for freedom in their grooves and set them with the gaps at approximately 120 deg. radial spacing.
 - (2) Apply a coat of grease XG-275 and fit the special piston ring clip over the rings, leaving $\frac{1}{8}$ in. of the piston skirt projecting (*fig. 11*).

RESTRICTED

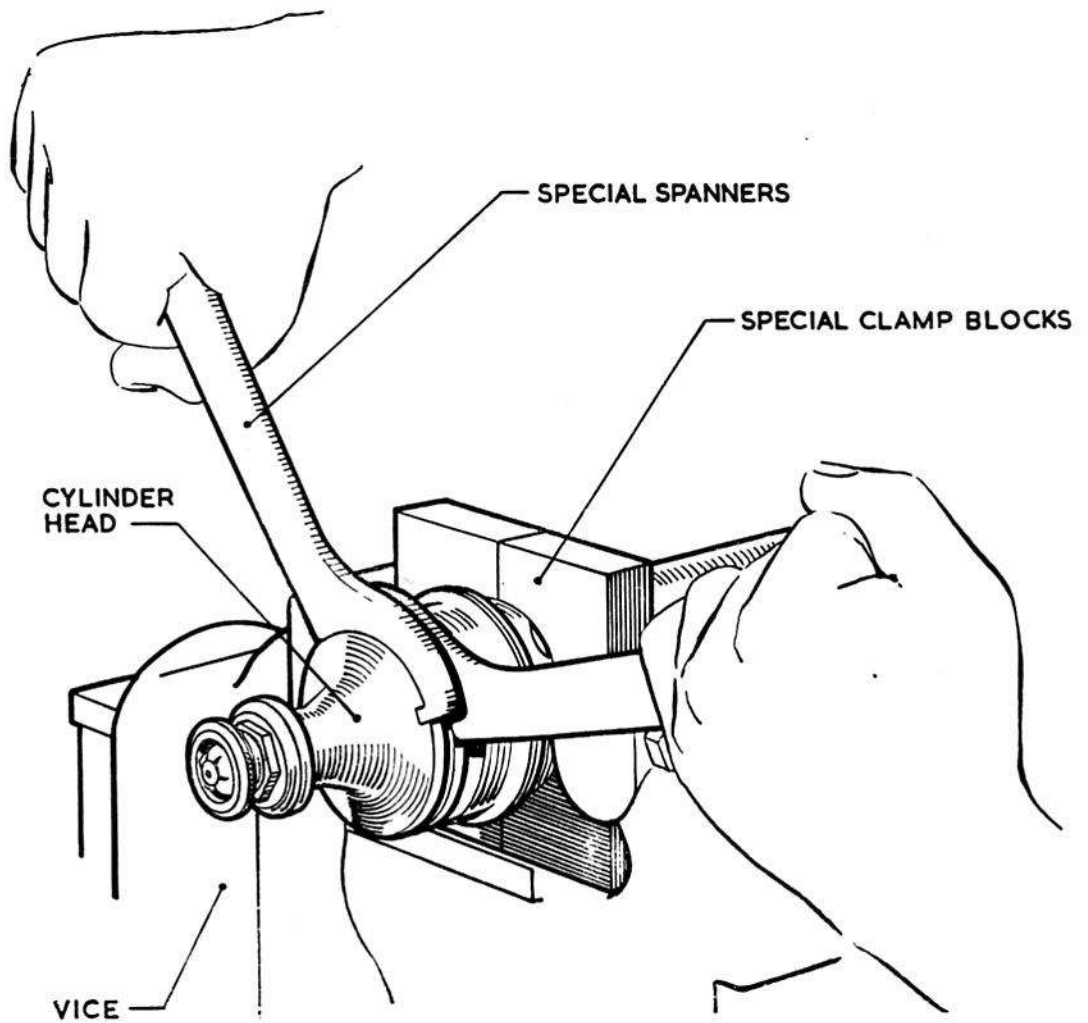

Fig. 6. Removing cylinder head

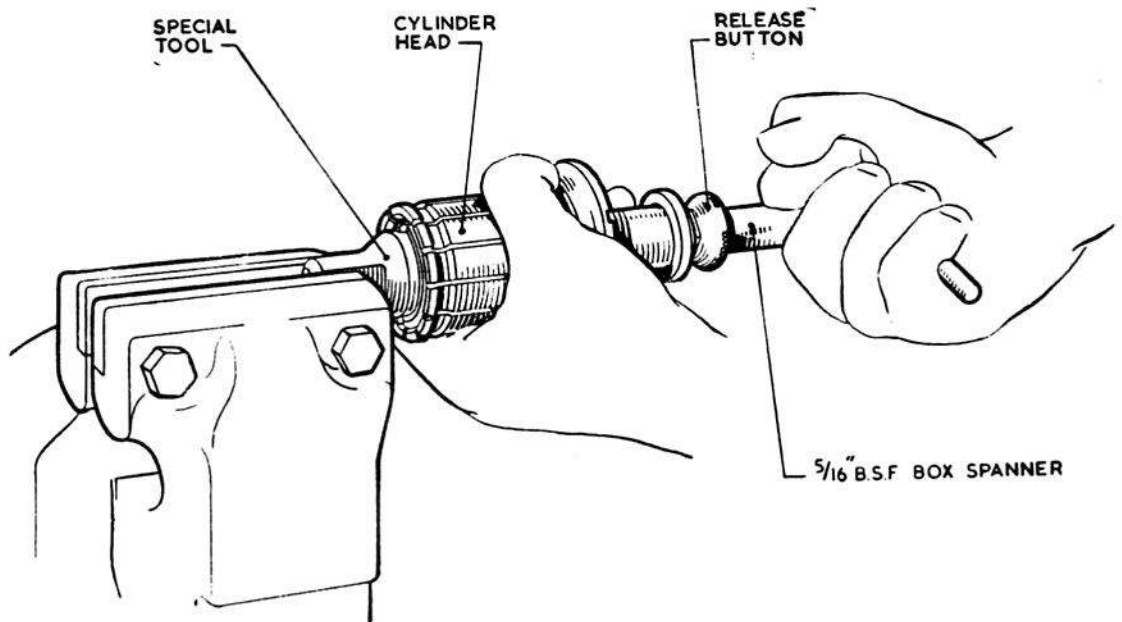

Fig. 7. Dismantling release piston

RESTRICTED

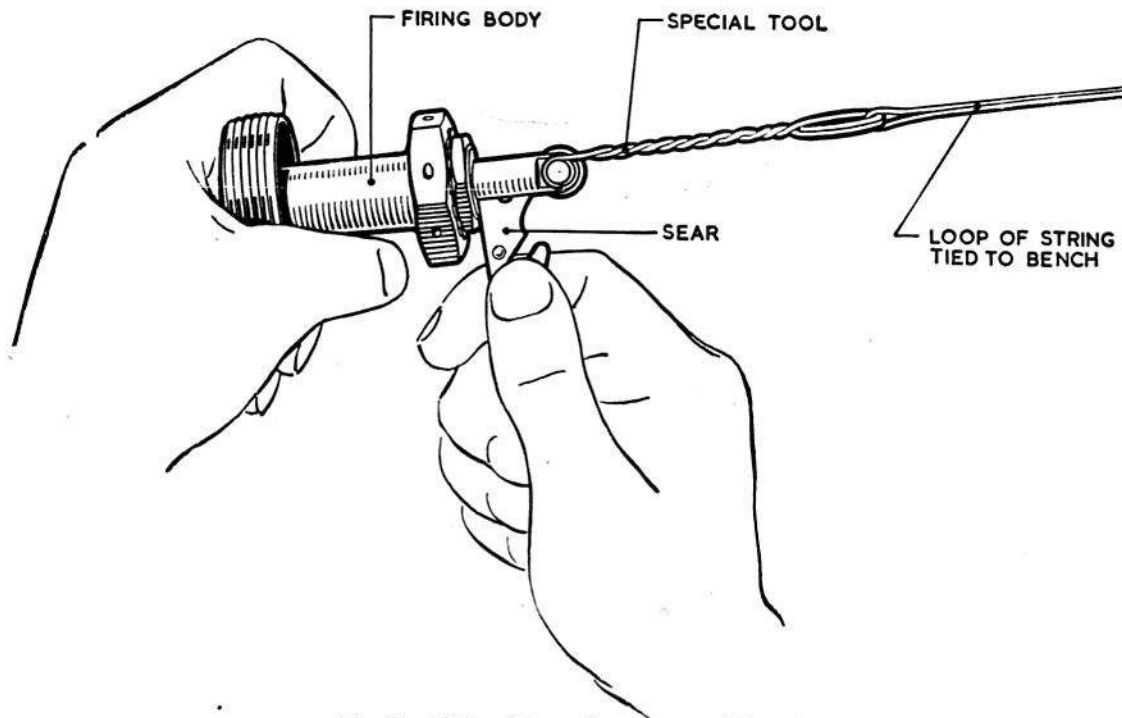

Fig. 8. Lifting firing pin with special tool

- (3) Carefully insert the piston skirt into the cylinder tube about 3 in. and remove the special clip.
- (4) Pull out the release button but do not release it until the piston tube has been pushed right home. When the release button is freed, the piston tube should be found to be locked into the cylinder tube against withdrawal. On no account should the piston tube be allowed to bottom hard before the release button is withdrawn, or the cylinder head locking tabs will be damaged.

Servicing the drogue gun

To remove the drogue gun cartridge

13.
 - (1) Break the sealed locking wire and unscrew the barrel, using a $\frac{7}{16}$ in. Whitworth spanner.
 - (2) Pull out the cartridge.

To test the time-delay and firing mechanisms

14. (1) The time-delay mechanism must operate in $\frac{1}{2} \pm \frac{1}{10}$ sec., and the method of testing is as follows:—
 - (a) Make a pencil holder as shown in fig. 12.
 - (b) Set up a drum in a lathe; the drum should be between 3 in. and 4 in. diameter, and between 4 in. and 5 in. in length. Cover the drum with plain paper secured in position with Selotape. Set the lathe to run at its lowest speed and check the r.p.m. with a tachometer.
 - (c) Set up the drogue gun in the lathe tool rest and screw the pencil holder in place of the cocking tool as shown in fig. 13.
 - (d) Adjust the slide rest to bring the point of the pencil to bear lightly on the left-hand edge of the paper on the drum.

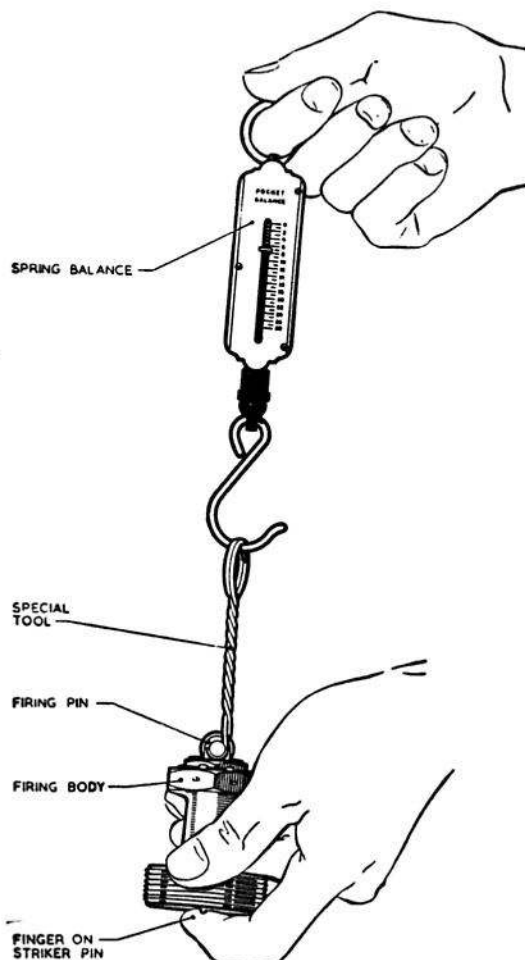

Fig. 9. Testing firing spring

RESTRICTED

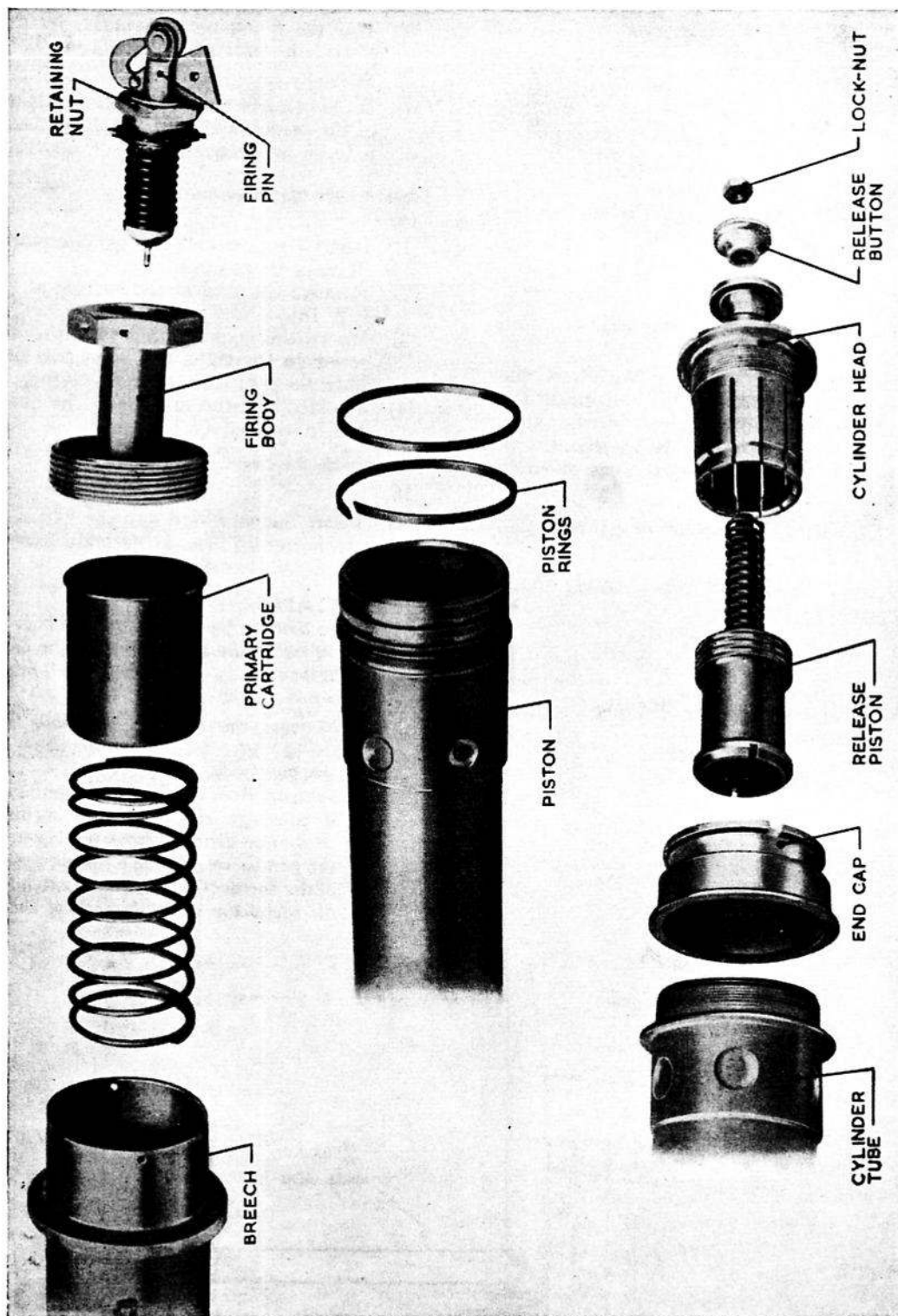

Fig. 10. Ejection gun components

RESTRICTED

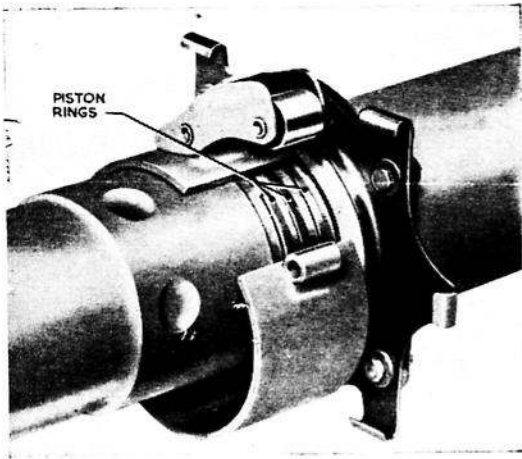

Fig. 11. Fitting piston ring clip

(c) With the drum rotating, withdraw the sear from the drogue gun and, using the following formula, calculate the time taken for the time-delay mechanism to operate. An example graph is given in fig. 14.

Where D = diameter of drum and N = r.p.m. :—

Desired distance of pencil travel round drum in $\frac{1}{2}$ sec :—

$$= \pi \frac{DN}{120}$$

Maximum permissible distance of travel round drum in $\frac{1}{10}$ sec :—

$$= \pi \frac{DN}{100}$$

Minimum permissible distance of travel round drum in $\frac{1}{10}$ sec :—

$$= \pi \frac{DN}{150}$$

- (2) With the firing mechanism in the fired condition, test the firing spring by inserting the cocking tool and applying a spring balance to the tool handle; it should not move at less than $10\frac{1}{2}$ lb.
- (3) Test the firing pin protrusion by the special gauge; the protrusion should not be less than $\frac{3}{32}$ in.
- (4) If the firing or time-delay mechanisms fail any of the prescribed tests, the unserviceable item is to be renewed.

To re-set the time-delay mechanism

15.

- (1) Insert the sear and depress the plunger until it locks in position.
- (2) Remove the stud at the bottom of the casing (fig. 15).
- (3) Insert the cocking tool into the stud hole, screw to the right and then pull downwards until the gear train stops revolving.
- (4) Replace the stud and insert the quick-release pin in the safety lock.

To assemble the drogue gun

16.

- (1) Insert the cartridge into the barrel and screw the barrel into the firing body firmly, using a $\frac{7}{16}$ in. Whitworth spanner.

IMPORTANT

Ensure that the top edge of the gun body is level with or above the scribed line on the barrel. If the scribed line has been obliterated, proceed as follows :—

- (a) Measure the distance internally between the cartridge seating and the upper edge of the gun body.
- (b) Subtract from this distance the thickness of a cartridge rim, and then measure the remaining distance from the lower edge of the gun barrel. Scribe a line on the exterior of the barrel at this distance; extend the line all round the circumference of the barrel.

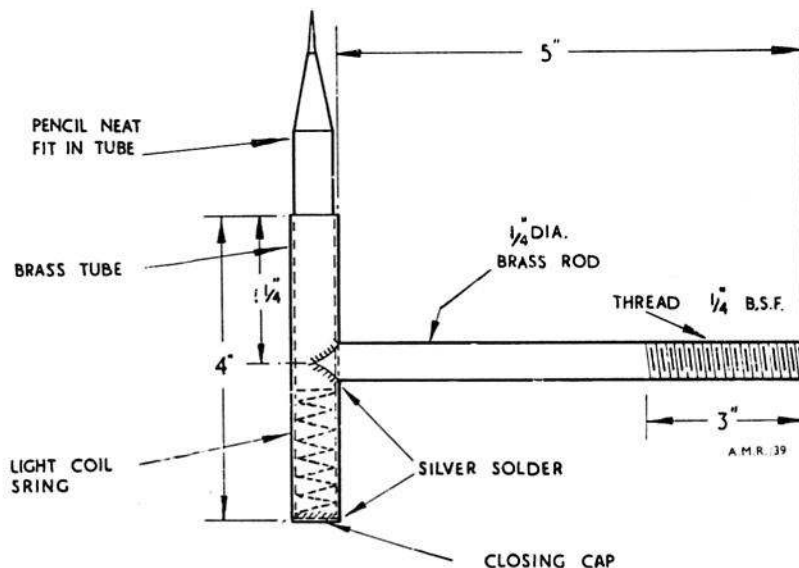

Fig. 12. Pencil holder

RESTRICTED

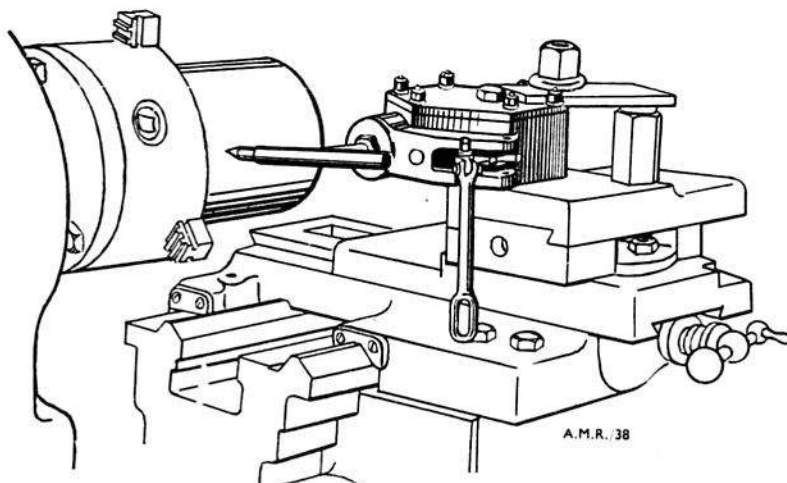

Fig. 13. Method of setting up lathe

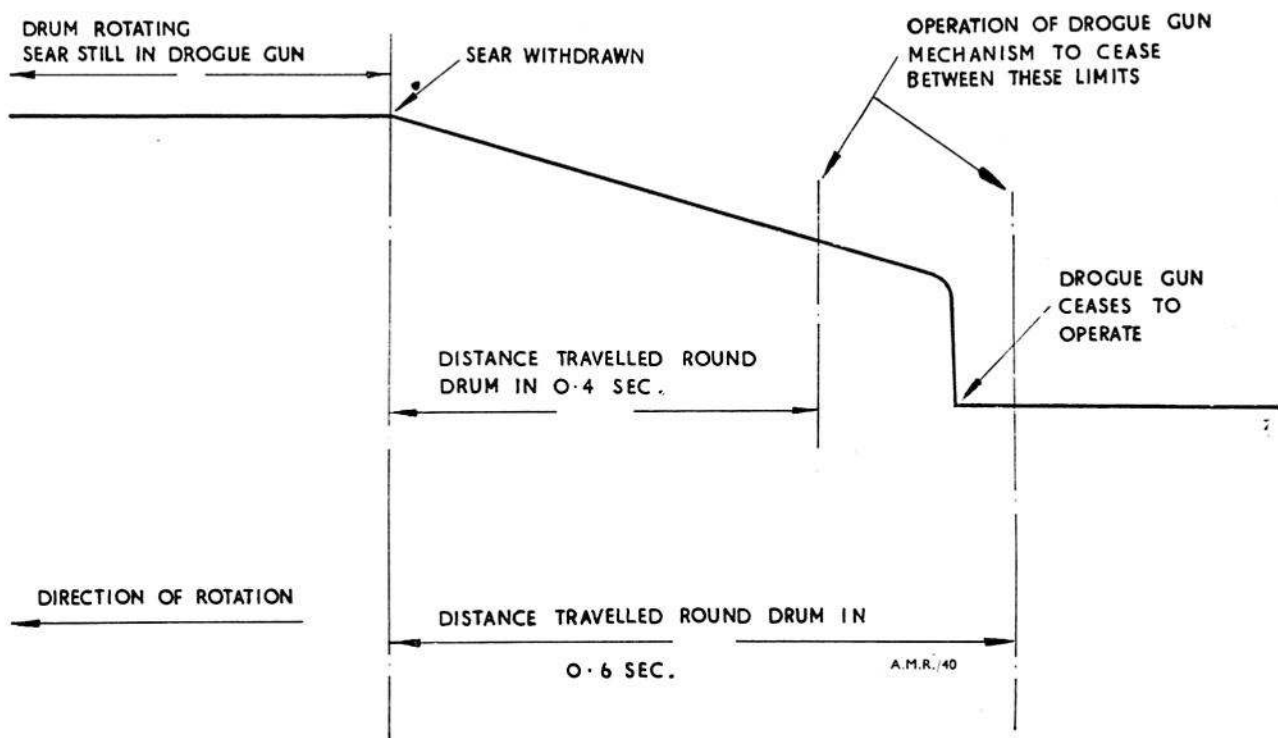

Fig. 14. Specimen graph

- (c) Fit the drogue cartridge and screw down the barrel. If the top edge of the gun body is not level with or above the scribed line after tightening fully, dismantle the gun, recheck the measurements and, if necessary, scribe a new line.
- (d) Make an entry in the Aircraft Servicing Form.
- (2) Lock with new 20 S.W.G. non-corrodible steel wire and seal (Stores Ref. 29H/1761), using the special pliers. (A.L.23) *(Stores Ref. No. B.11/3634)*
- (3) Replace the piston, which should be lightly wiped with grease XG-275, and insert a $\frac{1}{16}$ in. A.G.S.166/3 split pin in one of the holes provided.

Servicing the seat structure

To remove the seat pan

17.

- (1) Pull out the withdrawal knobs and hinge the parachute container upwards out of the way.

(A.L.16, Oct., 55)

RESTRICTED

- (2) Remove the manual harness release control cables from the bracket on the side member by unscrewing the two 2 B.A. bolts and detach the cross-shaft lever from the cross-shaft by undoing the nut and bolt. To facilitate removal, undo the special nut at the pivoting point of the radius arm and ease the radius arm out sufficiently to withdraw the cross-shaft lever.
- (3) Remove the automatic harness release cable from the side of the seat pan by undoing the four 4 B.A. nuts.
- (4) Disconnect the starboard safety harness thigh strap from the pan.
- (5) Disconnect the oxygen and anti-G suit supply pipes from the clips on the side of the seat pan.

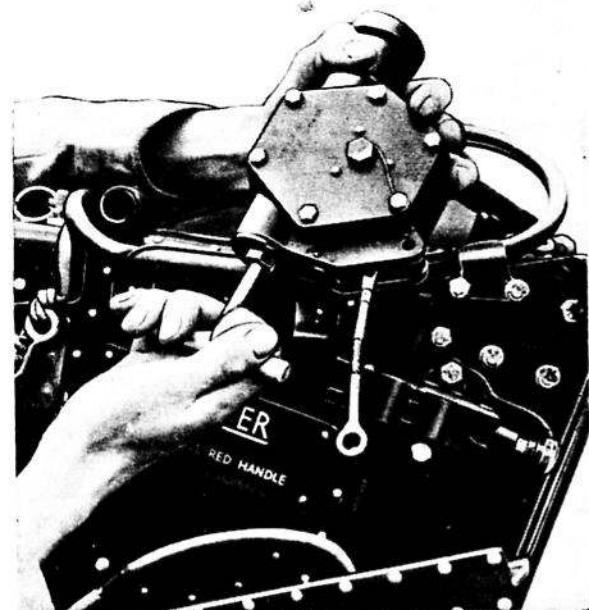
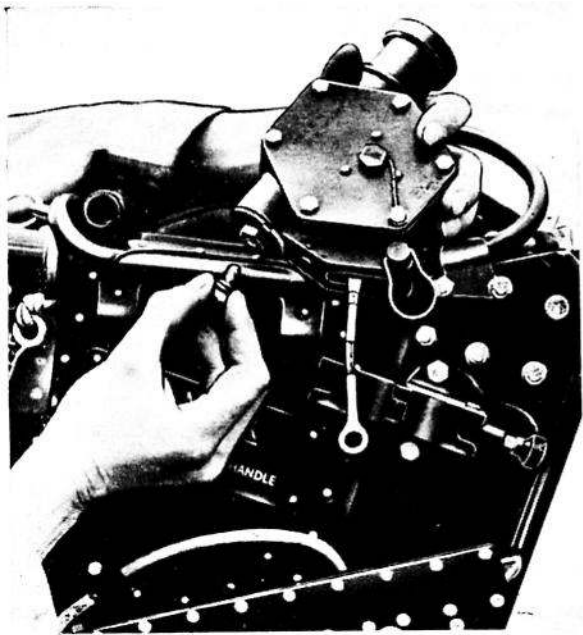

Fig. 15. Re-setting drogue gun time-delay mechanism

- (6) Adjust the seat to its top position whilst sitting in the seat to counteract the load of the seat balance springs.
- (7) Remove the two bolts attaching the footrest radius rods to the seat pan.
- (8) Remove the locking wire from the two spring-loaded plungers and, while pressing the pan back against the seat to relieve the plungers of the balance spring load, slide outwards the spring-loaded plungers. Allow the pan to hinge forward under the force of the balance springs until the springs are relaxed; they may then be removed.
- (9) Remove the bolts from the ends of the seat raising levers and remove the seat pan.

To remove and dismantle the parachute container radius arms

18.

- (1) Withdraw the split pin and remove the special nut at the starboard upper corner of the parachute container, and withdraw the transverse tube to port from the container.
- (2) Remove the clamping bolt and the nut, and withdraw sideways the radius arm body and the lever simultaneously.
- (3) Remove the split pin and spring retaining block and withdraw the plunger.
- (4) Remove the retaining screw and withdraw the sliding member from the radius arm body.

To examine and assemble the parachute container radius arms

19.

- (1) Check that all components are free from corrosion and that all moving parts operate freely without excessive slackness.
- (2) Check that the radius arms are straight in both planes and that there are no signs of burring on the notch faces; remove any burrs with a slip stone.
- (3) Lightly smear all moving parts with grease XG-275.
- (4) Insert the radius arm into the radius arm body and tighten the retaining screw.
- (5) Insert the plunger and spring retaining block and split pin.
- (6) Assemble the radius arm body and lever, insert the clamping bolt and tighten the nut.
- (7) Insert the transverse tube, tighten the special nut and lock with a split pin.

To dismantle the seat raising mechanism

20.

- (1) Remove the 2 B.A. lock-nut and tap out the taper pin from the port end of the counter-shaft. Remove the roller from the counter-shaft fitting. Do not remove the $\frac{1}{4}$ in. bolts from the faces of the seat raising lever bosses.
- (2) Remove the two quadrants by removing the four lock-nuts on each quadrant, and depressing the trigger control on the seat raising handle to free the plungers as the quadrant is withdrawn; the four bolts remain in place.

RESTRICTED

- (3) Remove the seat raising handle by withdrawing the pin and tapping out the seat raising handle hinge pin.
- (4) Push up the two plungers simultaneously and pull out the sear bar from the starboard side.
- (5) Remove both plungers and springs and withdraw the countershaft to starboard out of the port seat raising lever and countershaft bearings. Remove the spring retainer, spring and plunger from the end of the countershaft and, if necessary, the starboard seat raising lever.

To examine the seat raising mechanism

21.

- (1) Check that all components are free from corrosion and that all rollers rotate freely without excessive slackness on their pins.
- (2) Check that the sear bar is straight in both planes and free from wear on the ramp faces.
- (3) Check that the locking plungers and springs move freely in their housings in the seat raising levers.

To assemble the seat raising mechanism

Note . . .

Lubricate all parts during assembly with Grease XG-275.

22.

- (1) Pass the shaft with the starboard seat raising lever attached through the bearings in the side beams, and pass the port raising lever with the countershaft end fitting attached on to the shaft. Assemble the roller and split pin.

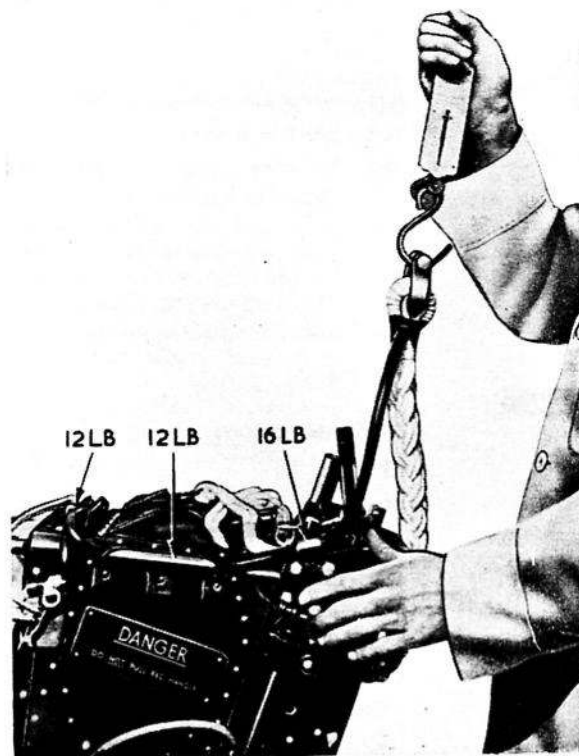

Fig. 16. Testing the lifting lines

- (2) Insert the locking plungers and springs into the raising levers and, whilst depressing each plunger in turn, insert the sear bar into the countershaft, passing it through the slots in the locking plungers.
- (3) Replace the plunger, spring and spring retainer into the end of the countershaft, and insert the taper pin and lock-nut.
- (4) Replace the quadrants and the seat raising handle.

To fit the seat pan

23.

- (1) Place the pan on the seat raising levers, which must be in the top position, and insert and secure the bolts.
- (2) Insert the seat balance springs and press the pan back against the seat, so compressing the springs. Operate the spring-loaded plungers to engage with the guides in the side beams and lock with non-corrodible steel locking wire. Ensure that the spring-loaded plungers have engaged correctly.
- (3) Replace the harness release cables and foot-rest radius rods.
- (4) Connect the parachute container to the lower brackets by operating the release knobs.
- (5) Connect the starboard safety harness thigh strap.
- (6) Connect the oxygen and anti-G suit supply pipes.

Testing the lifting lines

24.

- (1) Disconnect the drogue withdrawal line from the drogue shackle, and disconnect the drogue shackle from the scissor shackle.
- (2) Connect a spring balance to the drogue shackle and pull upwards. The lifting lines should not pull out of the first clip until the scale registers 16 lb. as indicated in fig. 16

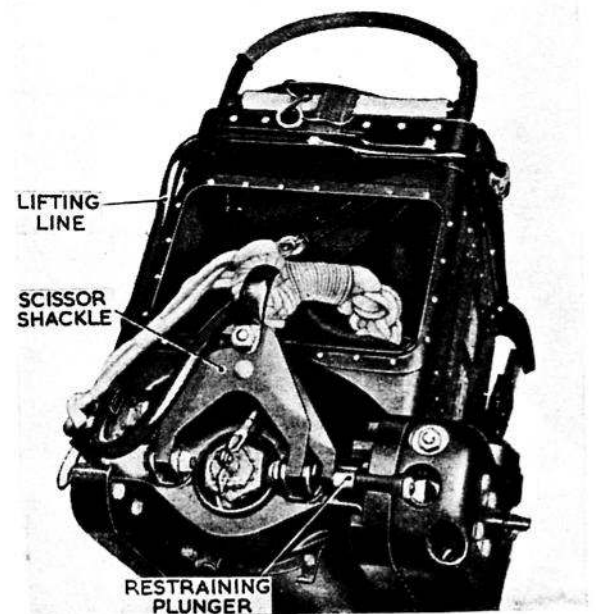

Fig. 17. Fitting the lifting lines

(A.L.16, Oct., 55)

RESTRICTED

and 12 lb. for the remaining clips. A tolerance of ± 2 lb. is permissible; the retaining clips may be sprung open or closed in as necessary.

Fitting the lifting lines

25. Commencing at the front of the drogue container, press the lifting lines down into their clips, using thumb pressure until the final result is similar to that shown in fig. 17.

Servicing the barostatic time-release unit

Note . . .

The mechanism is not to be lubricated.

26. (1) Ensure that the time-delay mechanism operates in $3 \pm \frac{1}{4}$ sec. If the timing is incorrect, the unit should be renewed.

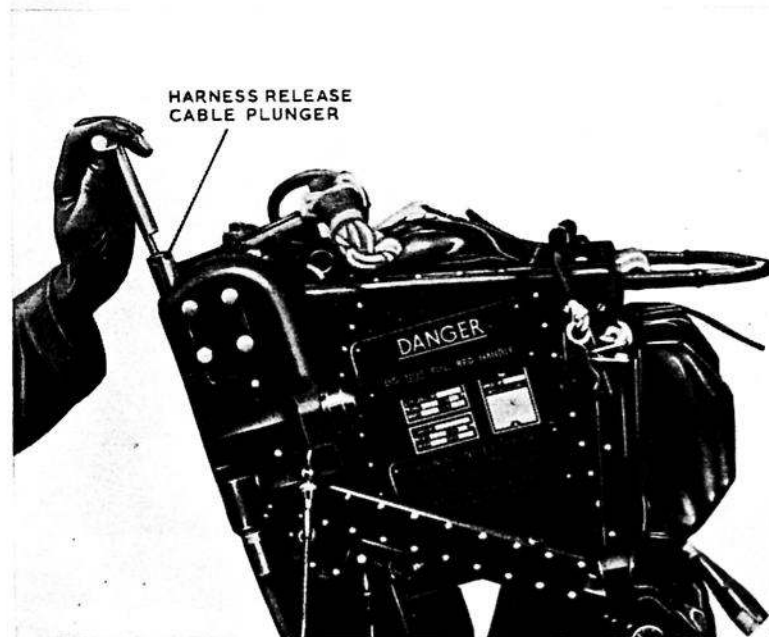
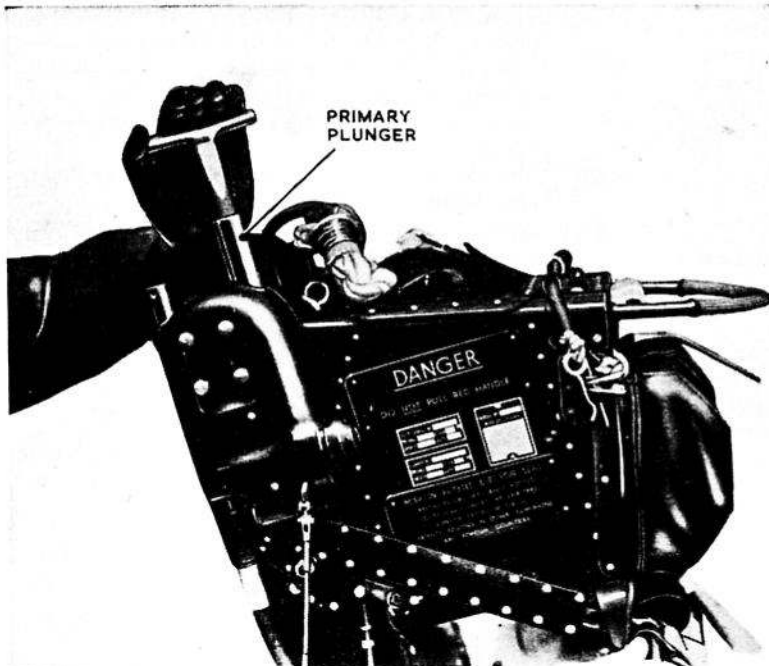

Fig. 18. Re-setting the barostatic time-release mechanism

- (2) If the timing is correct, re-cock the mechanism, remove the unit from the seat and pass it to the (L) Section for servicing in accordance with A.P.1275A, Vol. 4.
- (3) Service the safety harness and quick-release fitting in accordance with A.P.1182B, Vol. 4.

To fit and re-set the time-release unit

27.

- (1) Assemble the unit to the starboard seat beam by fitting and tightening the four $\frac{1}{4}$ in. B.S.F. nuts.
- (2) Assemble the safety harness release cable conduit and starboard thigh strap.
- (3) Turn the operating plunger until the word 'Top' is at the bottom, insert the sear from the top, depress the plunger until it engages and then rotate a half-turn.
- (4) Close the scissor shackle over the drogue shackle, and slide the locking plunger to the left until it rests against the scissor shackle.
- (5) Place the rack plunger tool over the primary plunger (fig. 18) and press down until it engages.
- (6) Place the harness release plunger tool over the plunger, ensuring that the cut-away portion of the tool is facing forward, and press down until it engages. Whilst doing so, place the other hand on the safety harness quick-release lever and assist it round to the locked position.

Servicing the face screen and drogue

To test the face screen

28. Connect a spring balance to the firing handle (fig. 19) and pull until the spring-loaded plungers disengage, watching the scale whilst doing so. The face screen should not pull out of its housing until the scale registers 25 to 45 lb.

To examine the face screen

29.

- (1) Withdraw the face screen to its fullest extent.
- (2) Examine the fabric of the face screen and check the security of the attachment of the front edge to the firing handle and the two fittings at the rear edge.
- (3) Examine the attachment of the firing cable to the face screen.

RESTRICTED

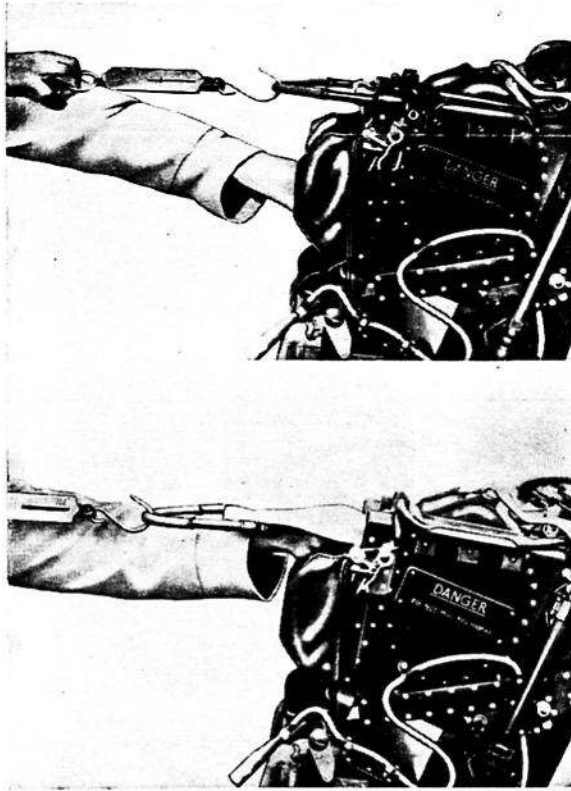

Fig. 19. Testing the face screen

To pack the face screen

30.

- (1) Starting with the face screen fully extended, carefully roll the screen over the lower edge of the slot in the container, pressing it down into its compartment, until the final result is as nearly as possible as shown in Chap. 3, fig. 6.
- (2) Insert the firing handle into its socket, but before pressing home the locking plungers, ensure that the restraining plate is located behind the firing handle cross-bar.

To examine the drogues

31.

- (1) Break the thread attaching the flap securing pin to No. 4 flap and withdraw the pin.
- (2) Fold back the four flaps and withdraw the drogues and shroud lines.
- (3) Examine the drogues, shroud lines and nylon rope for damage or deterioration.

To pack the drogues

32.

- (1) Open the four flaps and the protective sleeve.
- (2) Insert the sleeve-protected shroud lines from the shackle into the rearmost outer corner of the right-hand compartment of the drogue container and fold the shroud lines as shown in the upper diagram of fig. 20.
- (3) Extend the remaining shroud lines and check that they are not entangled; fold the 5 ft. drogue into three double folds and pack into the left-hand compartment.

- (4) Cover the shroud lines and the 5 ft. drogue with the protective sleeve. The 5 ft. drogue withdrawal line must emerge from the protective sleeve in the right-hand compartment.
- (5) Fold the 5 ft. drogue withdrawal line and the 18 in. drogue shroud lines on top of the protective sleeve in the right-hand compartment and stow the 18 in. drogue as shown in the lower diagram of fig. 20.
- (6) Close the flaps in the following order:—port (1), starboard (2) rear (3) and front (4). The wire loop must pass through each eyelet in turn and the 18 in. drogue withdrawal line must emerge from the rearmost corner nearest the drogue gun.
- (7) Insert the flap securing pin attached to the 18 in. drogue withdrawal line through the wire loop and tie to the fabric loop on the front flap with a single loop of No. 8 linen thread (Stores Ref. 15A/108).

Fitting the ejection gun in the guide rail

33. Carefully insert the ejection gun into the guide rail, taking care not to damage the cylinder tube by allowing it to strike the walls of the guide rail. Rotate the gun through 90 deg. to bring the secondary cartridge housing into the lightning hole opposite the cover plate. Pull out the bottom latch and press the gun home.

Note . . .

The ejection gun is to be examined for correct locking of the piston tube to the cylinder tube immediately prior to, and after, assembly in the guide rail. In addition, a physical check is to be conducted to ensure that the ejection gun itself is securely anchored in the guide rail.

Installing the seat in the aircraft

34.

- (1) Carefully place the seat over the guide rail, register the rollers in the guides and lower the seat until the top latch engages.
- (2) Insert the safety pin (fig. 5).
- (3) Connect the time-release unit static line by inserting the quick-release pin.
- (4) Connect the intercom. lead and the main and emergency oxygen connections.
- (5) Push the scissor shackle forward into the horizontal position.

IMPORTANT . . .

Obstruction to closing of the hood (accompanied by hood damage) will occur if the scissor shackle is left in the vertical position. The embodiment of Mod. No. Ejection Seat 163 and 203 tends to retain the scissor shackle in the vertical position after it is used for lowering the seat in the aircraft. It is essential therefore for the shackle to be horizontal before lowering the hood.

RESTRICTED

(A.L.23, July 56)

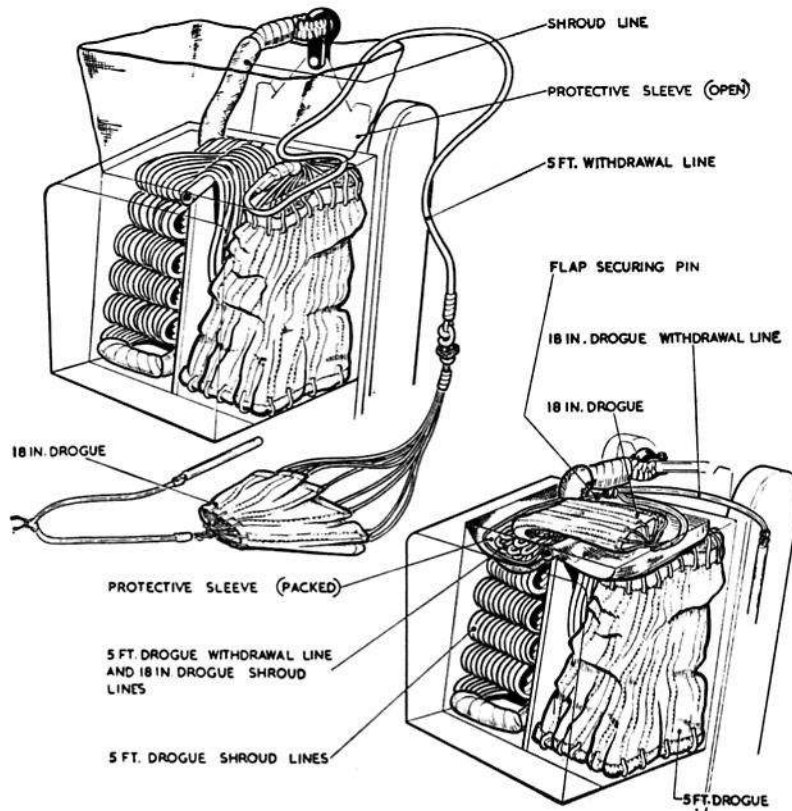

Fig. 20. Stowing the drogues

Fitting the drogue gun

35.

- (1) Assemble the drogue gun in the quick-release clamps.
- (2) Connect the static line and drogue withdrawal line.

Fitting the primary cartridge

36.

- (1) Insert the cartridge spring into the breech.
- (2) Insert the primary cartridge and press it into the breech with the firing body until the thread engages.
- (3) Screw in the firing body as far as possible by hand and tighten with the combination spanner.
- (4) Lock with new 20 S.W.G. non-corrodible steel locking wire and seal with a lead seal using the special pliers.

Note . .

Before sealing, cut the ends of the locking wire short and make certain that the loose ends of wire have been removed, otherwise they may subsequently prevent the seat structure being dropped right home and the latch engaging.

- (5) Insert the safety pin in the hole in the sear.

- (6) Connect the firing cable to the sear, ensuring that it passes through the legs of the scissor shackle.

Fitting the secondary cartridge

37.

- (1) Insert the secondary cartridge and replace the cartridge cover; tighten with the combination spanner.
- (2) Turn the gun slightly to port to expose the locking tab and thread a length of 20 S.W.G. non-corrodible steel locking wire through the hole.
- (3) Rotate the gun to its normal position, lock and seal with a lead seal, using the special pliers.
- (4) Close the cover plate in the seat pan.

Note . . .

When aircraft servicing is completed, transfer the safety pin from the hole in the sear to the face screen lock.

RESTRICTED

This file was downloaded
from the RTFM Library.

Link: www.scottbouch.com/rtfm

Please see site for usage terms,
and more aircraft documents.

