

## Chapter 5

(This chapter supersedes that issued with A.L. 5, 16 and 23)

### SERVICING

#### LIST OF CONTENTS

	Para.		Para.
Special tools ... ..	1	To examine and assemble the parachute container radius arms ... ..	19
Removing the primary cartridge ... ..	2	To dismantle the seat raising mechanism ... ..	20
Removing the drogue gun from the seat ... ..	3	To examine the seat raising mechanism ... ..	21
Removing the seat from the aircraft ... ..	4	To assemble the seat raising mechanism ... ..	22
Removing the ejection gun from the guide rail ... ..	5	To fit the seat pan ... ..	23
Removing the secondary cartridges ... ..	6	Testing the lifting lines ... ..	24
Servicing the ejection gun		Fitting the lifting lines ... ..	25
To extend the piston tubes from the cylinder tube ... ..	7	Servicing the barostatic time-release unit ... ..	26
To remove the release mechanism from the cylinder tube ... ..	8	To fit and re-set the time-release unit ... ..	27
To examine the release mechanism ... ..	9	Servicing the face screen and drogue	
To examine the firing mechanism ... ..	10	To test the face screen ... ..	28
To assemble the release mechanism in the cylinder tube ... ..	11	To examine the face screen ... ..	29
To examine and assemble the piston tubes ... ..	12	To pack the face screen ... ..	30
Servicing the drogue gun		To examine the drogues... ..	31
To remove the drogue gun cartridge ... ..	13	To pack the drogues ... ..	32
To test the time-delay and firing mechanisms ... ..	14	Fitting the secondary cartridges ... ..	33
To re-set the time-delay mechanism ... ..	15	Fitting the ejection gun in the guide rail ... ..	34
To assemble the drogue gun ... ..	16	Installing the seat in the aircraft ... ..	35
Servicing the seat structure		Fitting the drogue gun ... ..	36
To remove the seat pan ... ..	17	Fitting the primary cartridge ... ..	37
To remove and dismantle the parachute container radius arms ... ..	18		

#### LIST OF ILLUSTRATIONS

	Fig.		Fig.
Special tools ... ..	1	Examining intermediate piston tube rings ... ..	12
Disconnecting firing cable from seat ... ..	2	Examining inner piston tube rings ... ..	13
Drogue gun safety lock ... ..	3	Pencil holder ... ..	14
Removing the drogue gun ... ..	4	Method of setting up lathe... ..	15
Top latch safety pin ... ..	5	Specimen graph ... ..	16
Removing the secondary cartridges ... ..	6	Re-setting drogue gun time-delay mechanism ... ..	17
Removing cylinder head ... ..	7	Testing the lifting lines ... ..	18
Dismantling release piston... ..	8	Fitting the lifting lines ... ..	19
Lifting firing pin with special tool ... ..	9	Re-setting the barostatic time-release mechanism ... ..	20
Testing firing spring ... ..	10	Testing the face screen ... ..	21
Ejection gun components ... ..	11	Stowing the drogues ... ..	22

#### Special Tools (fig. 1)

1. The following is a list of the special tools required for servicing the ejection seat:—

Tool	Stores Ref. No.	Purpose
Combination spanner	27L/353	Access to primary and secondary cartridges
Spanner, secondary cartridge	27L/470	Access to secondary cartridges
Sealing pliers	Pat. B.11/1844	Sealing locking wires securing primary, secondary and drogue gun cartridges
Firing pin lifting tool	27L/98	Lifting firing pin of primary cartridge firing mechanism
Blocks, clamp	27L/486	Gripping cylinder tube in vice jaws
Spanner, release piston	27L/96	Restraining the release piston
Spanners, "C" (2 off)	27L/95	Removing and assembling cylinder head
Clips, piston ring	27L/92	Replacing piston tube in cylinder tube
Protrusion gauge	27L/186	Testing the firing pin protrusion of the primary and drogue gun firing units; testing the efficiency of the drogue gun cartridge retaining clip
Harness release plunger tool	27L/271	Re-setting barostatic time-release unit
Rack plunger tool	27L/272	Re-setting barostatic time-release unit
Drogue gun cocking tool	27L/273	Re-setting drogue gun time-delay mechanism

(A.L.26, Feb. 57)

**RESTRICTED**

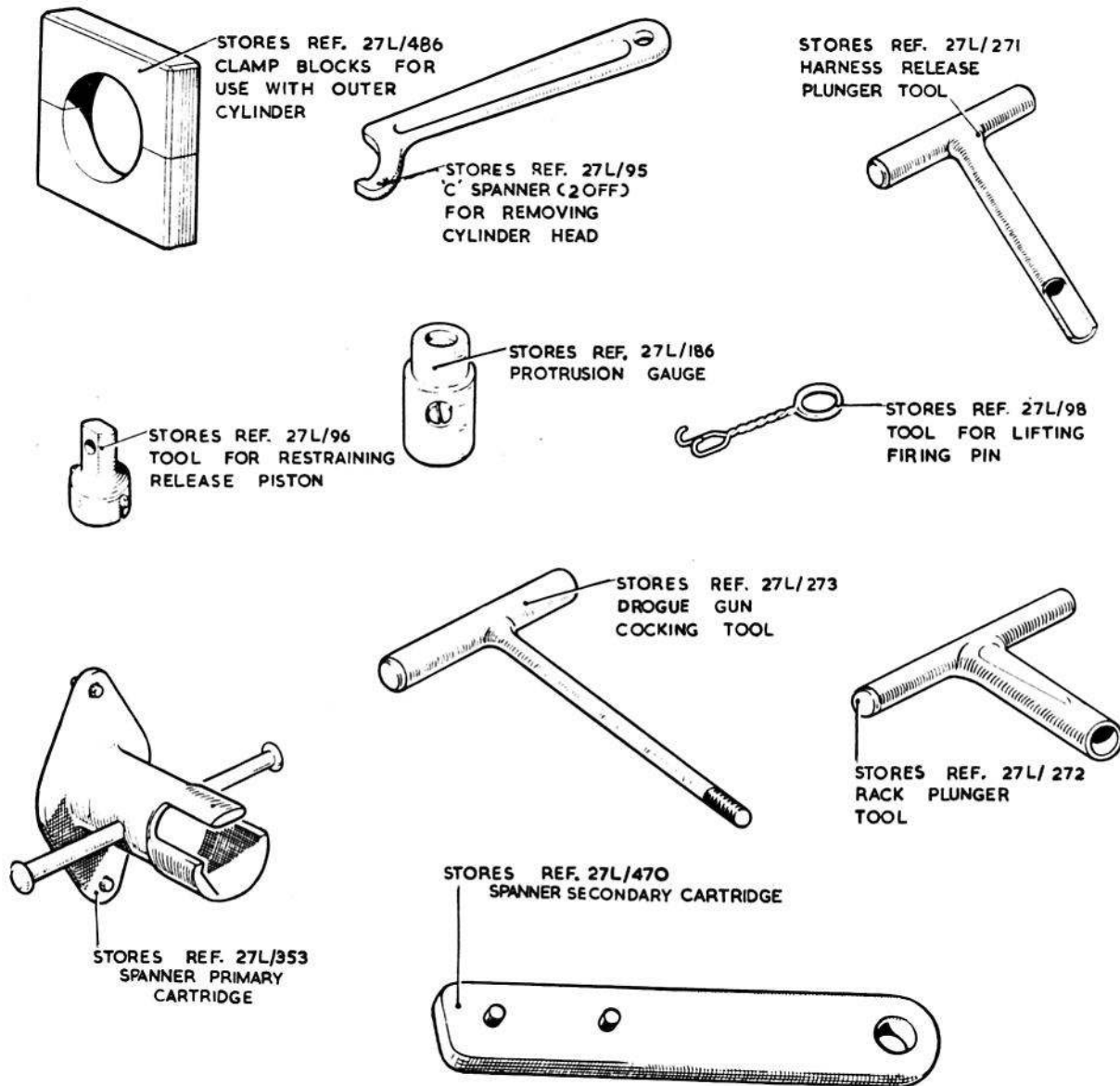

Fig. 1. Special tools

#### Removing the primary cartridge

##### IMPORTANT

The primary cartridge and the drogue gun MUST be removed before the seat is lifted from the aircraft.

2. (1) Place the safety pin in the hole in the sear.
- (2) Ease the firing sear forward by hand (fig. 2), and disconnect the eye end of the firing cable; the sear will automatically slide back to its original position.

##### WARNING

In no circumstances must the sear be extracted while the cartridge is in position. Any attempt to do so will result in the cartridge being fired.

- (3) Break the sealed locking wire, then fit the special spanner. Lift the safety pin disc and engage the holes in the disc with the two pegs on top of the spanner.
- (4) Unscrew the firing body from the breech. The primary cartridge will be pushed upwards

by a spring which should be removed with the cartridge; loosely replace the cartridge cover to exclude dust.

#### Removing the drogue gun from the seat

3. (1) Disconnect the static line by withdrawing the quick-release pin. Render the gun safe by inserting the pin in the safety lock (fig. 3).
- (2) Disconnect the drogue withdrawal line by pulling out the quick-release pin which attaches it to the drogue gun piston.
- (3) Operate the two quick-release clamps (fig. 4) and lift out the drogue gun.

#### Removing the seat from the aircraft

4. (1) Disconnect the intercom. lead and the main and emergency oxygen connections.
- (2) Remove the parachute and dinghy pack.
- (3) Disconnect the barostatic time-release unit static line from the bracket on the guide rail.

**RESTRICTED**

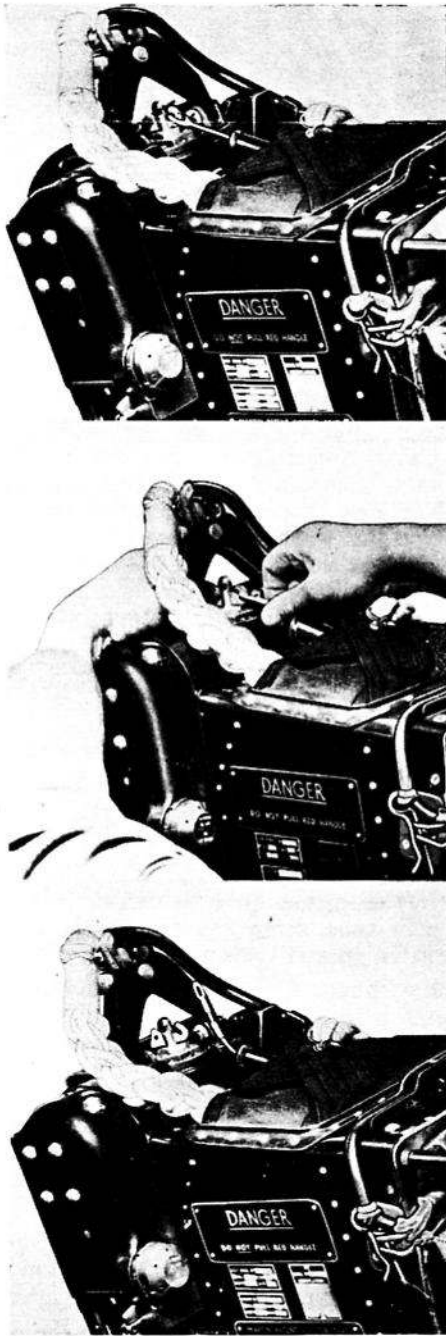

Fig. 2. Disconnecting firing cable from sear

- (4) Withdraw the safety pin from its housing (fig. 5), release the top latch and lift the seat up the guide rail.

**Removing the ejection gun from the guide rail**

5. Draw out the bottom latch by the ring, turn the gun through 90 deg. to bring the secondary cartridge housing into the guide rail and lift out the gun, taking care not to damage the cylinder tube by allowing it to strike the walls of the guide rail or any part of the aircraft.

**Removing the secondary cartridges**

6. (1) Break the sealed locking wire and unscrew each secondary cartridge cover, using the special spanner provided (fig. 6).
- (2) Remove the cartridges.
- (3) Loosely replace the covers to exclude dust.

**Servicing the ejection gun**

*To extend the piston tubes from the cylinder tube*

7. Pull out the release button to its full extent then ease the intermediate and inner piston tubes from the cylinder tube; *make no attempt to separate them from each other.*

*To remove the release mechanism from the cylinder tube*

8. (1) Grip the cylinder tube in the special clamp blocks (fig. 7), remove the locking wire and unscrew the cylinder head, using the special C-spanners provided. Do not remove the end cap from the cylinder tube.
- (2) Remove the lock-nut in the release button with a  $\frac{3}{8}$  in. B.S.F. box-spanner, at the same time restraining the release piston from turning by engaging the special tool in the slots provided (fig. 8).
- (3) Pull off the release button; the release piston and spring can then be withdrawn from the cylinder head.

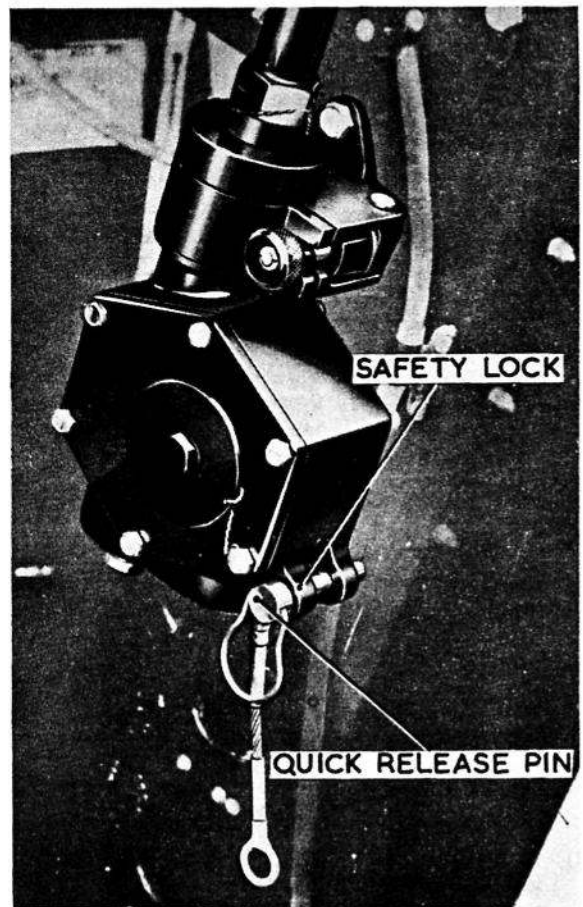

Fig. 3. Drogue gun safety lock

(A.L.26, Feb. 57)

**RESTRICTED**

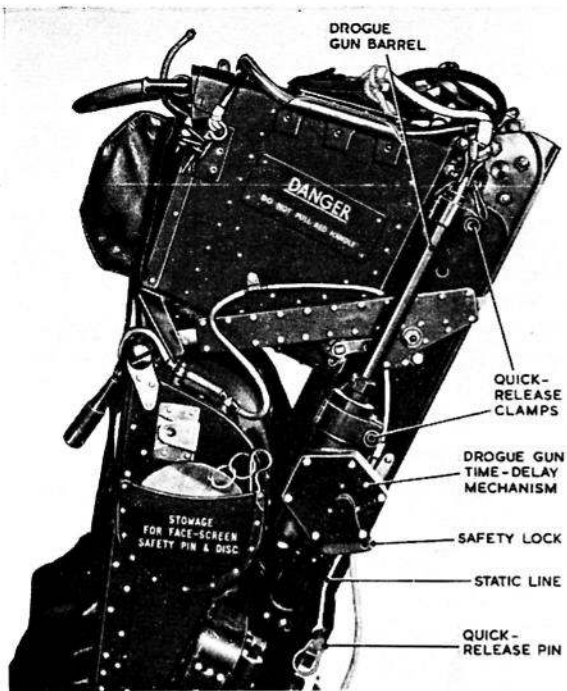

Fig. 4. Removing the drogue gun

To examine the release mechanism

9. (1) Check that all parts are free from corrosion.
- (2) Check that the locking tabs on the cylinder head are undamaged.
- (3) Check that the release piston slides freely in the cylinder head and that the drain holes in the cylinder head and piston are clear.

To examine the firing mechanism

10. (1) With the firing pin in the fired position, place the protrusion gauge in position in the firing unit. If the plunger is flush with, or above, the level of the body, the protrusion is low.
- (2) Remove the firing pin from the firing body. Using kerosine, wash any traces of grease from the firing pin and the interior of the firing body, then lightly lubricate with oil, OM-13 (N.S. Patt. E.9/4422). Assemble the firing pin in the firing body.
- (3) Lift the firing pin with the special tool (fig. 9) and check that the firing sear moves freely in the slot, and that the firing pin moves freely throughout its stroke. Remove the sear and check the initial compression of the firing spring by the spring balance as shown in fig. 10. The firing pin should not start to move until 7 lb. is registered. The initial movement of the firing pin can be detected by holding the finger over the projecting end of the striker pin.
- (4) If the action of the firing pin when checked as described in sub-para. (3) is unsatisfactory, the retaining nut (fig. 11) should be unscrewed with a  $\frac{5}{8}$  in. box

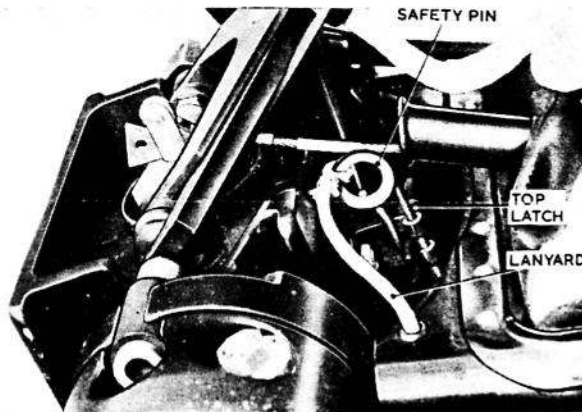

Fig. 5. Top latch safety pin

spanner, after the tab of the brass locking washer is bent down, and the firing pin assembly should be renewed complete with a new locking washer. Ensure that the locking washer tab already bent down engages the slot in the top of the firing body, and after the retaining nut has been firmly screwed down, one of the other tabs should be bent up to lock it.

- (5) Repeat the checks described in sub-para. (3).

To assemble the release mechanism in the cylinder tube

11. (1) Apply a coat of grease XG-275 (Stores Ref. 34B/222) and assemble the release piston and spring into the cylinder head, using the special spanner.
- (2) With the piston tube withdrawn from the cylinder tube, screw the cylinder head back, using the special C-spanners.
- (3) Lock with new 22 S.W.G. non-corrodible steel locking wire.

To examine and assemble the piston tubes

12. (1) Gently extend the intermediate piston tube until the piston rings can be seen through one of the secondary cartridge housings (fig. 12).
- (2) Examine the piston rings for damage by gently rotating the intermediate piston tube and watching the rings through the aperture.
- (3) Apply a coat of grease XG-275 to the piston rings, then remove all trace of grease from the housing.

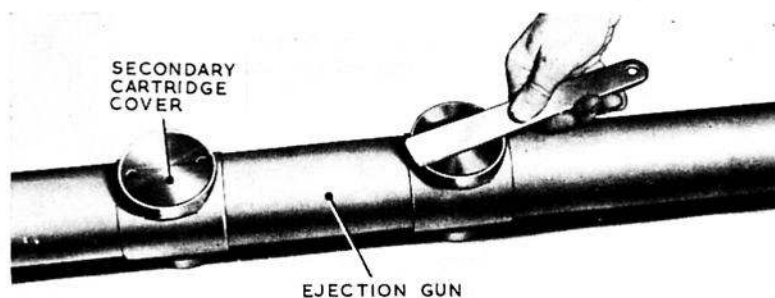

Fig. 6. Removing the secondary cartridges

RESTRICTED

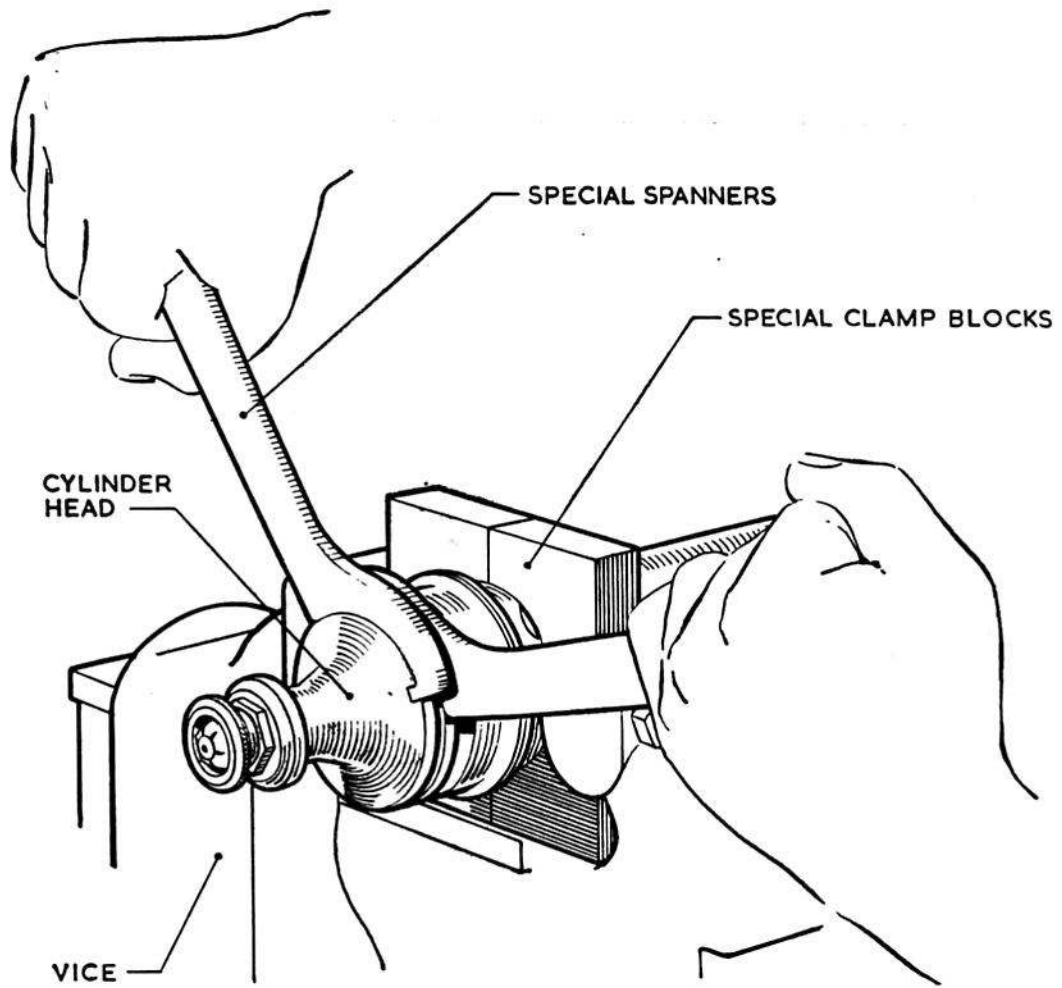

Fig. 7. Removing cylinder head

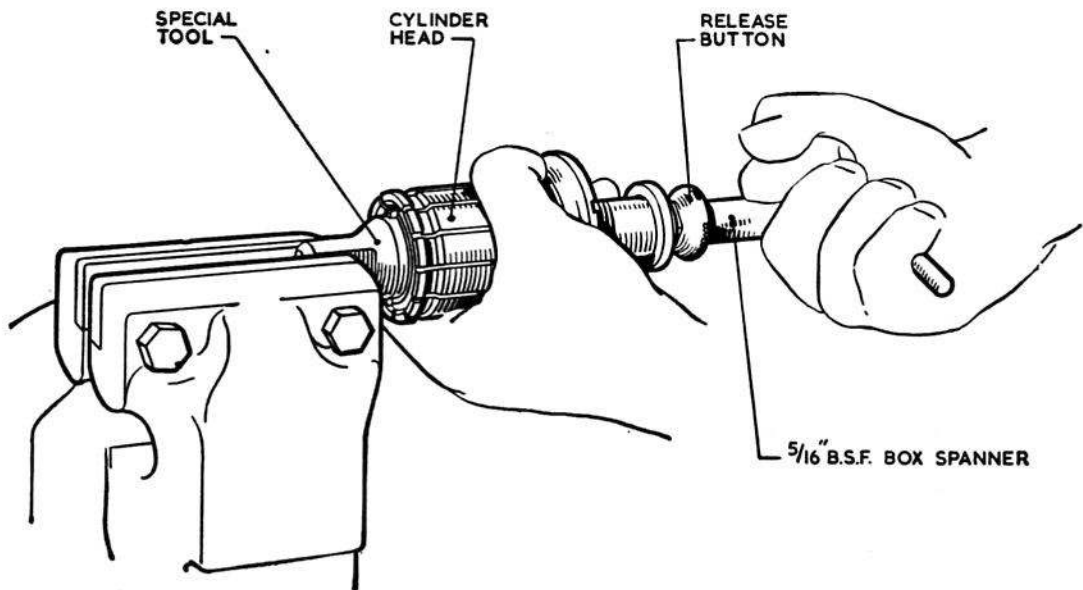

Fig. 8. Dismantling release piston

**RESTRICTED**

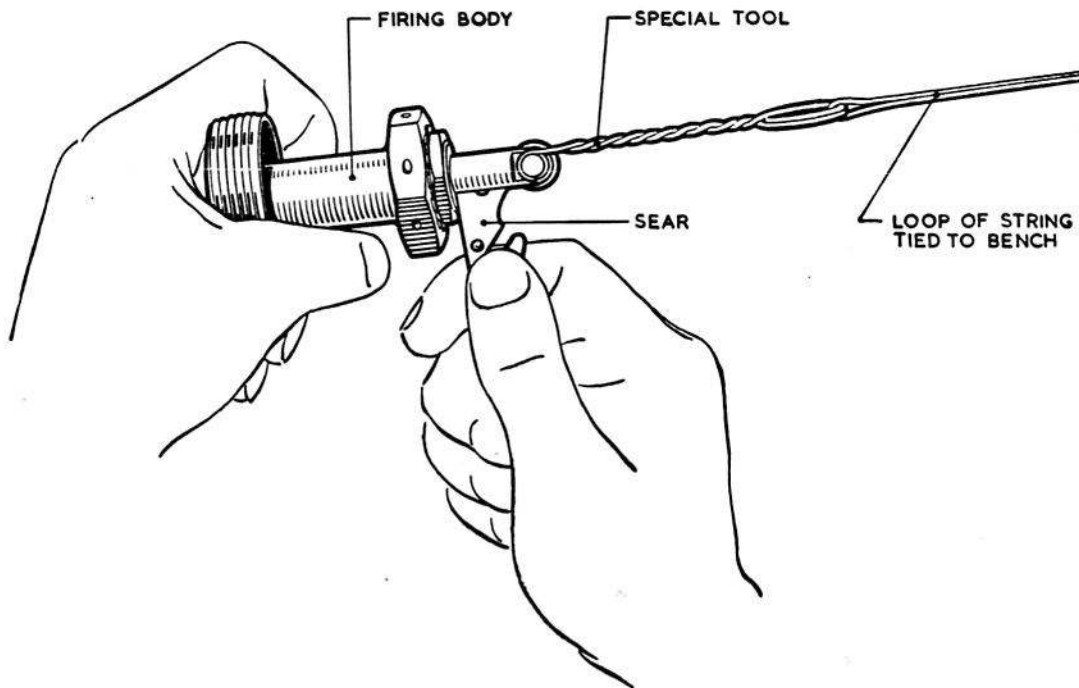

Fig. 9. Lifting firing pin with special tool

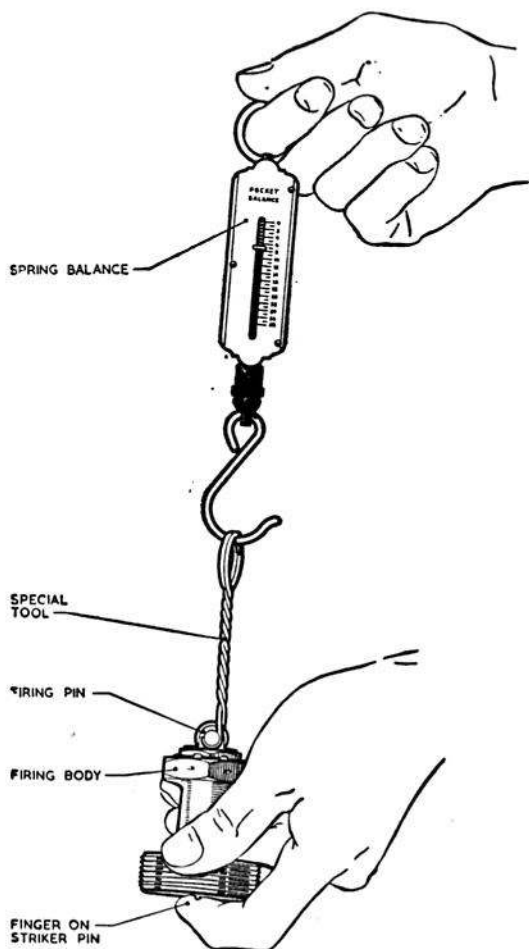

Fig. 10. Testing firing spring

- (4) Gently extend the inner piston tube until the piston rings can be seen through one of the flash holes (*fig. 13*).
- (5) Examine and lubricate the inner piston rings by repeating actions (2) and (3).
- (6) Gently ease in the inner piston tube until it is fully home in the intermediate piston tube.
- (7) Pull out the release button but do not release it until the piston tubes have been pushed, right home. When the release button is freed the piston tubes should be found to be locked into the cylinder tube against withdrawal. On no account should the piston tubes be allowed to bottom hard before the release button is withdrawn or the cylinder head locking tabs will be damaged.

#### Servicing the drogue gun

To remove the drogue gun cartridge

13. (1) Break the sealed locking wire and unscrew the barrel, using a  $\frac{7}{16}$  in. Whitworth spanner.
- (2) Pull out the cartridge.

To test the time-delay and firing mechanisms

14. (1) The time-delay mechanism must operate in  $\frac{1}{2} \pm \frac{1}{16}$  sec., and the method of testing is as follows:—
  - (a) Make a pencil holder as shown in *fig. 14*.
  - (b) Set up a drum in a lathe; the drum should be between 3 in. and 4 in. diameter, and between 4 in. and 5 in. in length. Cover the drum with plain paper secured in position with Selotape. Set the lathe to

RESTRICTED

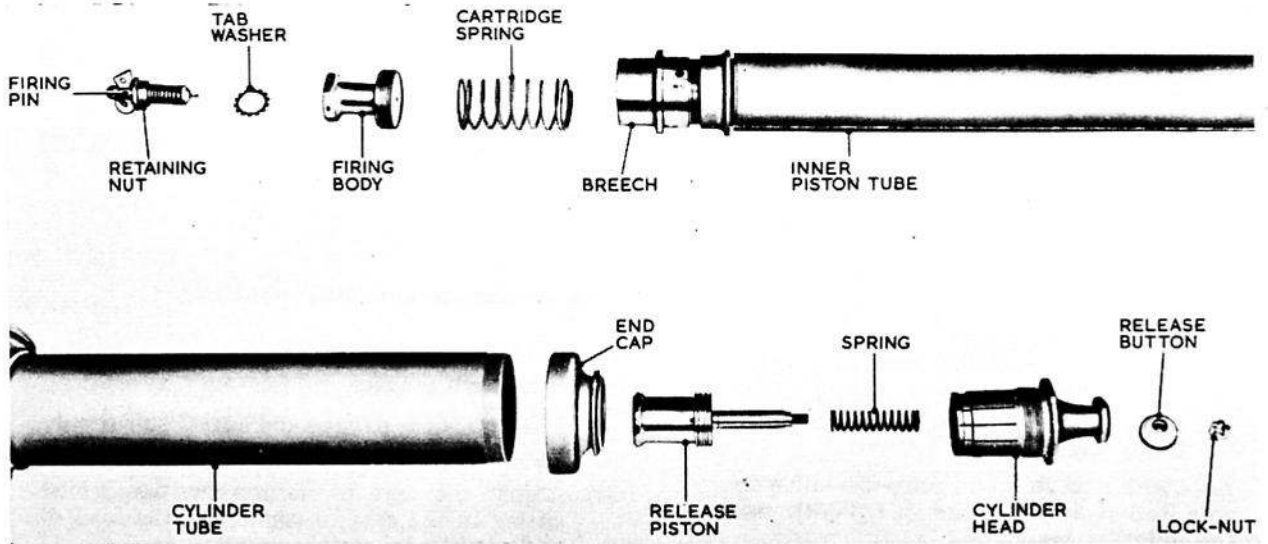

Fig. 11. Ejection gun components

- (c) Set up the drogue gun in the lathe tool rest and screw the pencil holder in place of the cocking tool as shown in fig. 15.
- (d) Adjust the slide rest to bring the point of the pencil to bear lightly on the left-hand edge of the paper on the drum.
- (e) With the drum rotating, withdraw the sear from the drogue gun and, using the following formula, calculate the time taken for the time-delay mechanism to operate. An example graph is given in fig. 16.

Where D=diameter of drum and N=r.p.m.:-

Desired distance of pencil travel round drum in  $\frac{1}{2}$  sec:-

$$= \pi \frac{DN}{120}$$

Maximum permissible distance of travel round drum in  $\frac{1}{10}$  sec:-

$$= \pi \frac{DN}{100}$$

Minimum permissible distance of travel round drum in  $\frac{1}{10}$  sec:-

$$= \pi \frac{DN}{150}$$

- (2) With the firing mechanism in the fired condition, test the firing spring by inserting the cocking tool and applying a spring balance to the tool handle; it should not move at less than 10½ lb.
- (3) Test the firing pin protrusion by the special gauge; the protrusion should not be less than  $\frac{3}{32}$  in.

- (4) If the firing or time-delay mechanisms fail any of the prescribed tests, the unserviceable item is to be renewed.

*To re-set the time-delay mechanism*

- 15. (1) Insert the sear and depress the plunger until it locks in position.
- (2) Remove the stud at the bottom of the casing (fig. 17).
- (3) Insert the cocking tool into the stud hole, screw to the right and then pull downwards until the gear train stops revolving.
- (4) Insert the quick-release pin in the safety lock.

*To assemble the drogue gun*

- 16. (1) Insert the cartridge into the barrel and screw the barrel into the firing body firmly, using a  $\frac{7}{8}$  in. Whitworth spanner.

**IMPORTANT**

*Ensure that the top edge of the gun body is level with or above the scribed line on the barrel. If the scribed line has been obliterated, proceed as follows:-*

- (a) Measure the distance internally between the cartridge seating and the upper edge of the gun body.

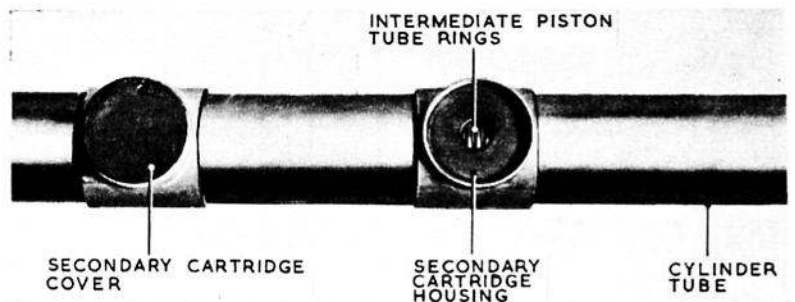

Fig. 12. Examining intermediate piston tube rings

**RESTRICTED**

(b) Subtract from this distance the thickness of a cartridge rim, and then measure the remaining distance from the lower edge of the gun barrel. Scribe a line on the exterior of the barrel at this distance; extend the line all round the circumference of the barrel.

(c) Fit the drogue gun cartridge and screw down the barrel. If the top edge of the gun body is not level with or above the scribed line after tightening fully, dismantle the gun, re-check the measurements and, if necessary, scribe a new line.

(d) Make an entry in the Aircraft Servicing Form 700.

- (2) Lock with new 20 S.W.G. non-corrodible steel wire and seal (Pat. No. B.11/3634), using the special pliers.
- (3) Replace the piston, which should be lightly wiped with grease XG-275, and insert a  $\frac{1}{16}$  in. A.G.S.166/3 split pin in one of the holes provided.

#### Servicing the seat structure

To remove the seat pan

17. (1) Pull out the withdrawal knobs and hinge the parachute container upwards out of the way.
- (2) Remove the manual harness release control cables from the bracket on the side member by unscrewing the two 2 B.A. bolts and detach the cross-shaft lever from the cross-shaft by undoing the nut and bolt. To facilitate removal, undo the special nut at the pivoting point of the radius arm and ease the radius arm out sufficiently to withdraw the cross-shaft lever.
- (3) Remove the automatic harness release cable from the side of the seat pan by undoing the four 4 B.A. nuts.

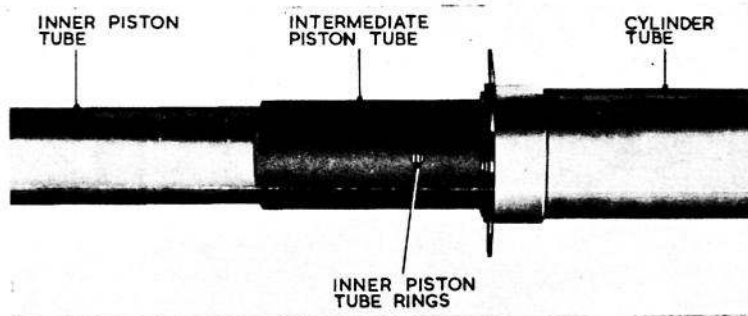

Fig. 13. Examining inner piston tube rings

- (4) Disconnect the starboard safety harness thigh strap from the pan.
- (5) Disconnect the oxygen and anti-G suit supply pipes from the clips on the side of the seat pan.
- (6) Adjust the seat to its top position whilst sitting in the seat to counteract the load of the seat balance springs.

#### Note . . .

The seat pan can be removed with the footrests still attached but, if necessary, the footrests can be detached by removing the appropriate bolts securing them to the seat pan.

- (7) Remove the locking wire from the two spring-loaded plungers and, while pressing the pan back against the seat to relieve the plungers of the balance spring load, slide outwards the spring-loaded plungers. Allow the pan to hinge forward under the force of the balance springs until the springs are relaxed; they may then be removed.
- (8) Remove the bolts from the ends of the seat raising levers and remove the seat pan.

To remove and dismantle the parachute container radius arms

18. (1) Withdraw the split pin and remove the special nut at the starboard upper corner of the parachute container, and withdraw the transverse tube to port from the container.

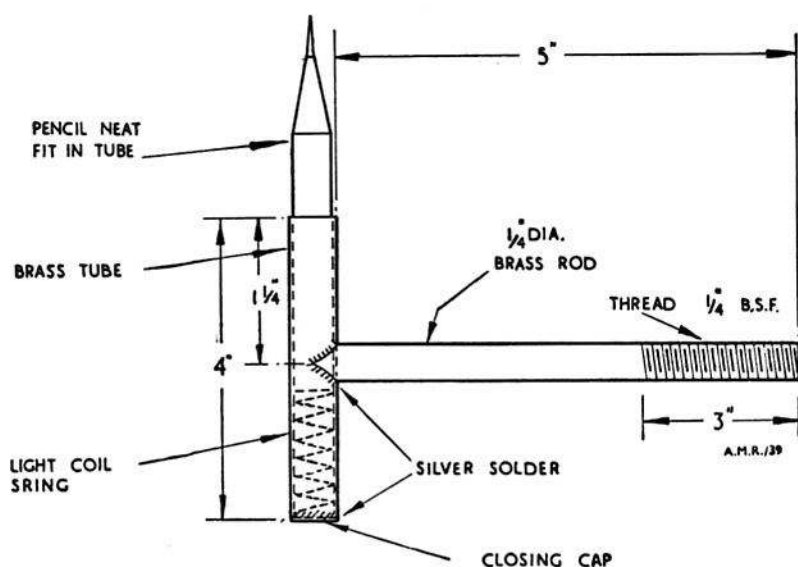

Fig. 14. Pencil holder

RESTRICTED

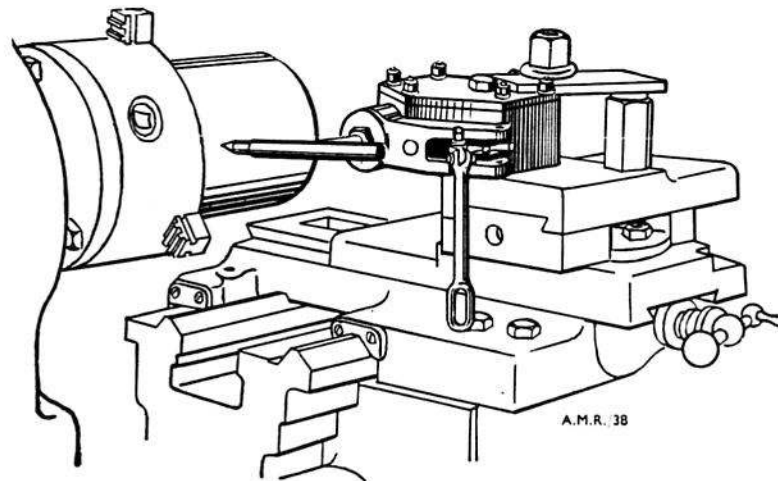

Fig. 15. Method of setting up lathe

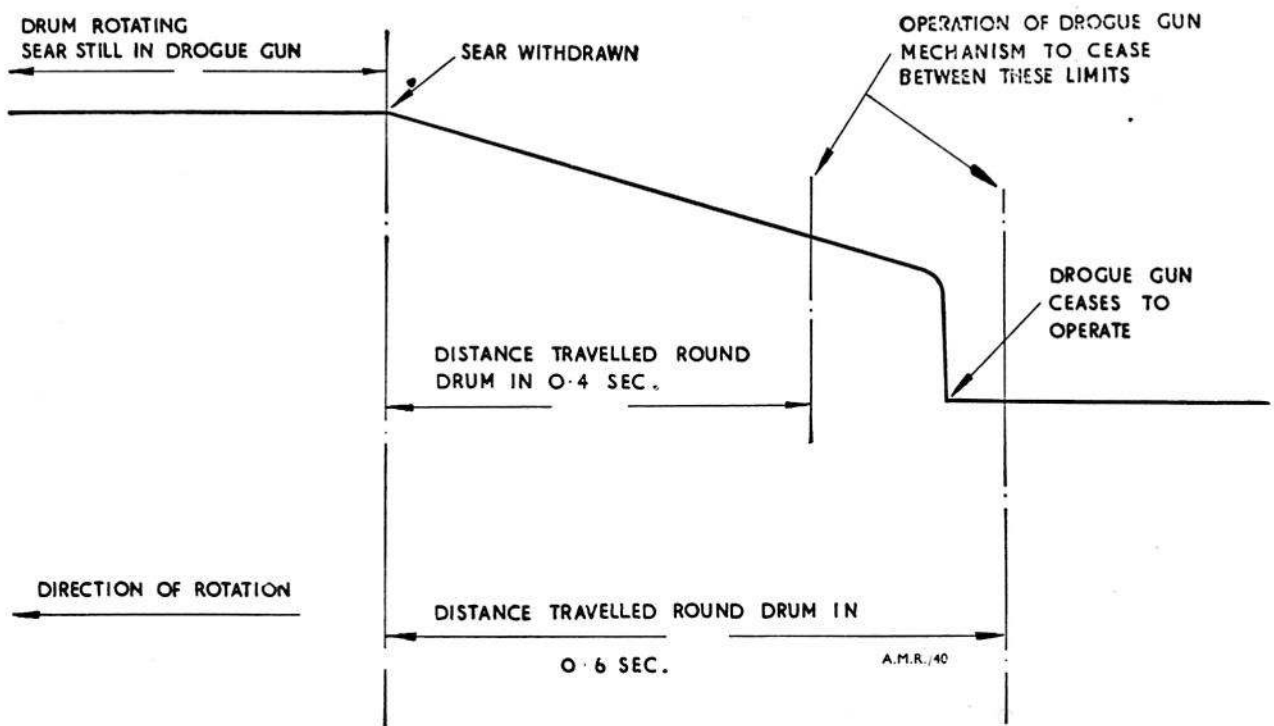

Fig. 16. Specimen graph

- (2) Remove the clamping bolt and the nut, and withdraw sideways the radius arm body and the lever simultaneously.
- (3) Remove the split pin and spring retaining block and withdraw the plunger.
- (4) Remove the retaining screw and withdraw the sliding member from the radius arm body.

To examine and assemble the parachute container radius arms

19. (1) Check that all components are free from corrosion and that all moving parts operate freely without excessive slackness.

- (2) Check that the radius arms are straight in both planes and that there are no signs of burring on the notch faces; remove any burrs with a slip stone.
- (3) Lightly smear all moving parts with grease XG-275.
- (4) Insert the radius arm into the radius arm body and tighten the retaining screw.
- (5) Insert the plunger and spring retaining block and split pin.
- (6) Assemble the radius arm body and lever, insert the clamping bolt and tighten the nut.

(A.L.26, Feb. 57)

**RESTRICTED**

- (7) Insert the transverse tube, tighten the special nut and lock with a split pin.

*To dismantle the seat raising mechanism*

20. (1) Remove the 2 B.A. lock-nut and tap out the taper pin from the port end of the countershaft. Remove the roller from the countershaft fitting. Do not remove the  $\frac{1}{4}$  in. bolts from the faces of the seat raising lever bosses.
- (2) Remove the two quadrants by removing the four lock-nuts on each quadrant, depressing the trigger control on the seat raising handle to free the plungers as the quadrant is withdrawn; the four bolts remain in place.

- (3) Remove the seat raising handle by removing the four  $\frac{1}{4}$  in. bolts securing it to the flange.
- (4) Push up the two plungers simultaneously and pull out the sear bar from the starboard side.
- (5) Remove both plungers and springs and withdraw the countershaft to starboard out of the port seat raising lever and countershaft bearings. Remove the spring retainer, spring and plunger from the end of the countershaft and, if necessary, the starboard seat raising lever.

*To examine the seat raising mechanism*

21. (1) Check that all components are free from corrosion and that all rollers rotate freely without excessive slackness on their pins.
- (2) Check that the sear bar is straight in both planes and free from wear on the ramp faces.
- (3) Check that the locking plungers and springs move freely in their housings in the seat raising levers.

*To assemble the seat raising mechanism*

**Note . . .**

*Lubricate all parts during assembly with Grease XG-275.*

22. (1) Pass the shaft with the starboard seat raising lever attached through the bearings in the side beams, and pass the port raising lever with the countershaft end fitting attached on to the shaft. Assemble the roller and split pin.
- (2) Insert the locking plungers and springs into the raising levers and, whilst depressing each plunger in turn, insert the sear bar into the countershaft, passing it through the slots in the locking plungers.

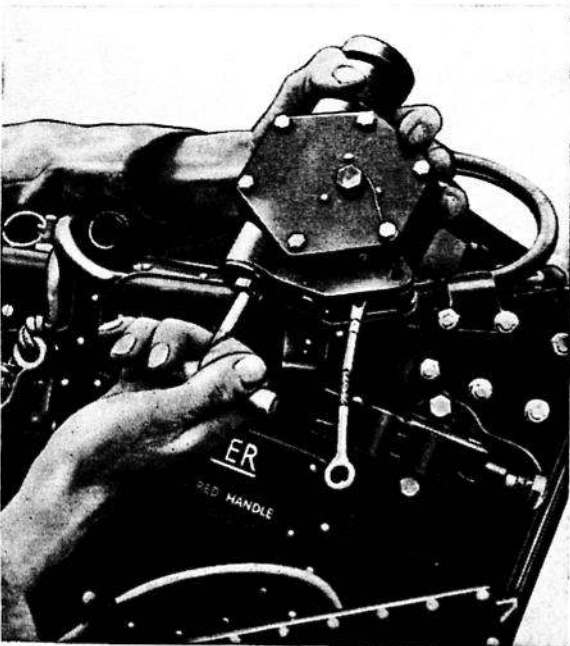
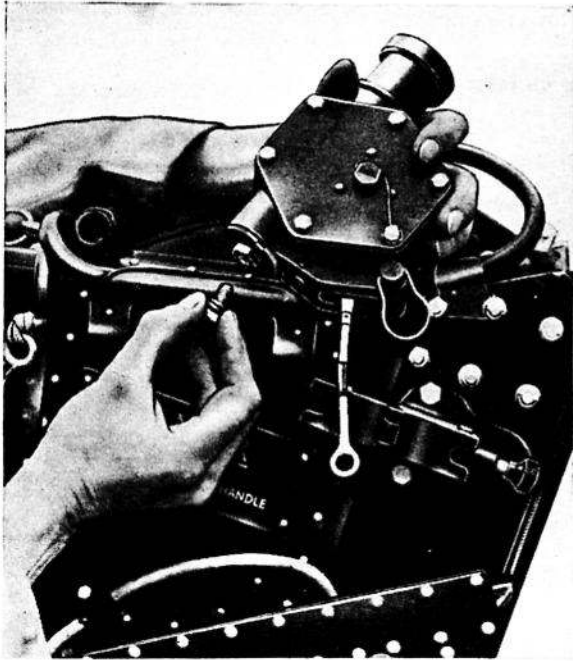

Fig. 17. Re-setting drogue gun time-delay mechanism



Fig. 18. Testing the lifting lines

**RESTRICTED**

- (3) Replace the plunger, spring and spring retainer into the end of the countershaft, and insert the taper pin and lock-nut.
- (4) Replace the quadrants and the seat raising handle.

*To fit the seat pan*

23. (1) Place the pan on the seat raising levers, which must be in the top position, and insert and secure the bolts.
- (2) Insert the seat balance springs and press the pan back against the seat, so compressing the springs. Operate the spring-loaded plungers to engage with the guides in the side beams and lock with non-corrodible steel locking wire. Ensure that the spring-loaded plungers have engaged correctly.
- (3) Replace the harness release cables and footrest radius rods.
- (4) Connect the parachute container to the lower brackets by operating the release knobs.
- (5) Connect the starboard safety harness thigh strap.
- (6) Connect the oxygen and anti-G suit supply pipes.

**Testing the lifting lines**

24. (1) Disconnect the drogue withdrawal line from the drogue gun piston, and disconnect the drogue shackle from the scissor shackle.
- (2) Connect the spring balance to the drogue shackle and pull upwards. The lifting lines should not pull out of the first clip until the scale registers 16 lb. as indicated in fig. 18, and 12 lb. for the remaining clips. A tolerance of  $\pm 2$  lb. is permissible; the retaining clips may be sprung open or closed in as necessary.

**Fitting the lifting lines**

25. Commencing at the front of the drogue container, press the lifting lines down into their clips, using thumb pressure, until the final result is similar to that shown in fig. 19.

**Servicing the barostatic time-release unit**

**Note . . .**

*The mechanism is not to be lubricated.*

26. (1) Ensure that the time-delay mechanism operates in 3 sec.  $\pm \frac{1}{4}$  sec. If the timing is incorrect, the unit should be renewed.
- (2) If the timing is correct, re-cock the mechanism, remove the unit from the seat and pass it to the (L) Section for servicing in accordance with A.P.1275A, Vol. 4.

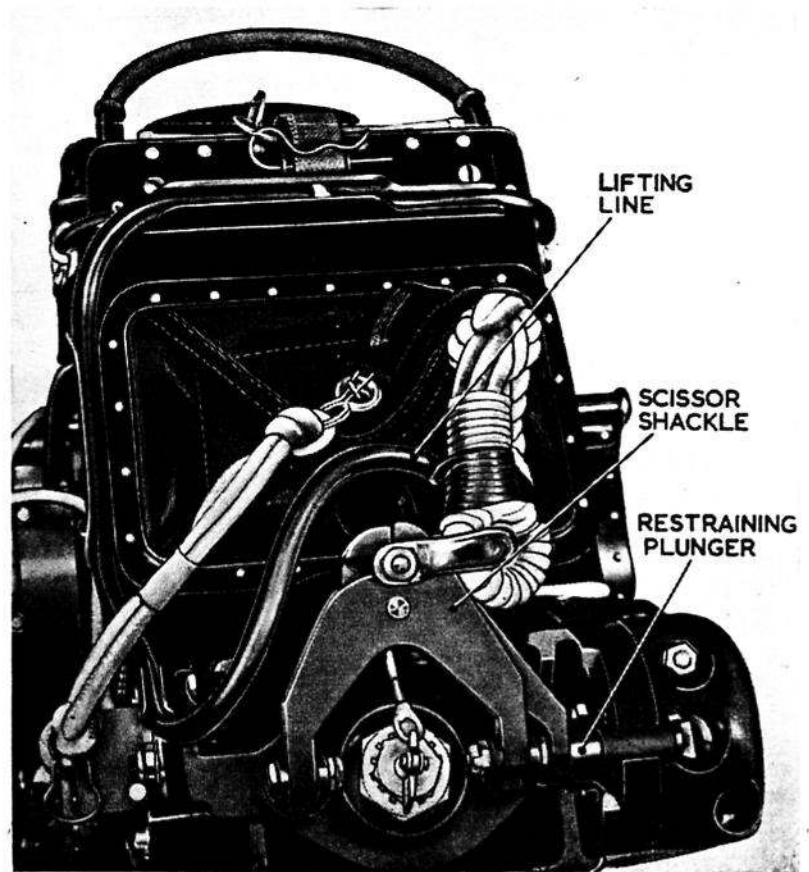

**Fig. 19. Fitting the lifting lines**

- (3) Service the safety harness and quick-release fitting in accordance with A.P.1182B, Vol. 4.

**To fit and re-set the time-release unit**

27. (1) Assemble the unit to the starboard seat beam by fitting and tightening the four  $\frac{1}{4}$  in. B.S.F. nuts.
- (2) Assemble the safety harness release cable conduit and starboard thigh strap.
- (3) Turn the operating plunger until the word 'Top' is at the bottom, insert the sear from the top, depress the plunger until it engages and then rotate a half-turn.
- (4) Close the scissor shackle over the drogue shackle, and slide the restraining plunger inwards until it rests against the scissor shackle.
- (5) Place the rack plunger tool over the primary plunger (*fig. 20*) and press down until it engages.
- (6) Place the harness release plunger tool over the plunger, ensuring that the cut-away portion of the tool is facing forward, and press down until it engages. Whilst doing so place the other hand on the safety harness quick-release lever and assist it round to the locked position.

(A.L.26, Feb. 57)

**RESTRICTED**

### Servicing the face screen and drogue

#### To test the face screen

28. Connect a spring balance to the firing handle (fig. 21) and pull until the spring-loaded plungers disengage, watching the scale whilst doing so. The face screen should not pull out of its housing until the scale registers 25 to 45 lb.

#### To examine the face screen

29. (1) Withdraw the face screen to its fullest extent.
- (2) Examine the fabric of the face screen and check the security of attachment of the front edge to the firing handle, and of the two rear fittings.
- (3) Examine the attachment of the firing cable to the face screen.

#### To pack the face screen

30. (1) Starting with the face screen fully extended, carefully roll the screen over the lower edge of the slot in the container, pressing it down into its compartment.
- (2) Insert the firing handle into its socket, but before pressing home the locking plungers, ensure that the restraining plate is located behind the firing handle cross-bar.

#### To examine the drogues

31. (1) Break the thread attaching the flap securing pin to No. 4 flap and withdraw the pin.
- (2) Fold back the four flaps and withdraw the drogues and shroud lines.
- (3) Examine the drogues, shroud lines and nylon rope for damage or deterioration.

#### To pack the drogues

32. (1) Open the four flaps and the protective sleeve.
- (2) Insert the sleeve-protected shroud lines from the shackle into the rearmost outer corner of the right-hand compartment of the drogue container and fold the shroud lines as shown in the upper diagram of fig. 22.
- (3) Extend the remaining shroud lines and check that they are not entangled; fold the 5 ft. drogue into three double folds and pack into the left-hand compartment.
- (4) Cover the shroud lines and the 5 ft. drogue with the protective sleeve. The 5 ft. drogue

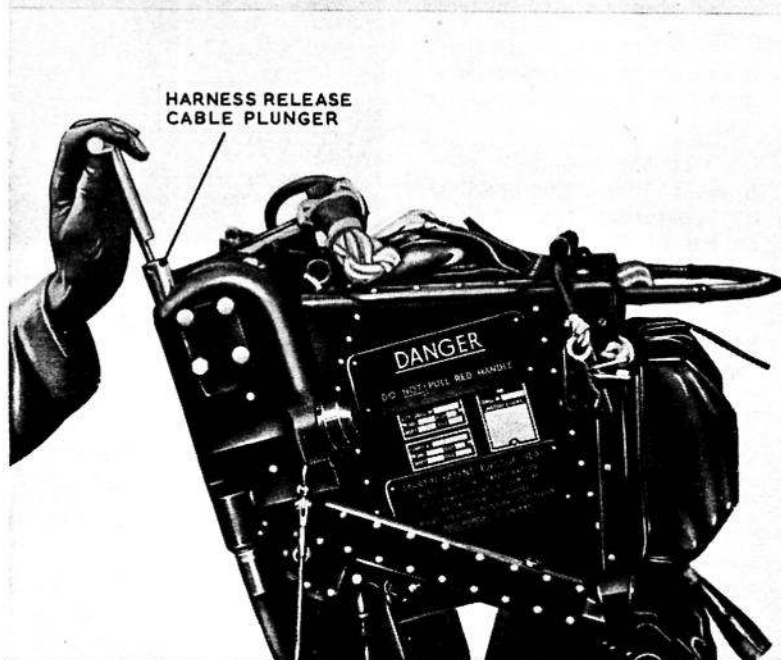
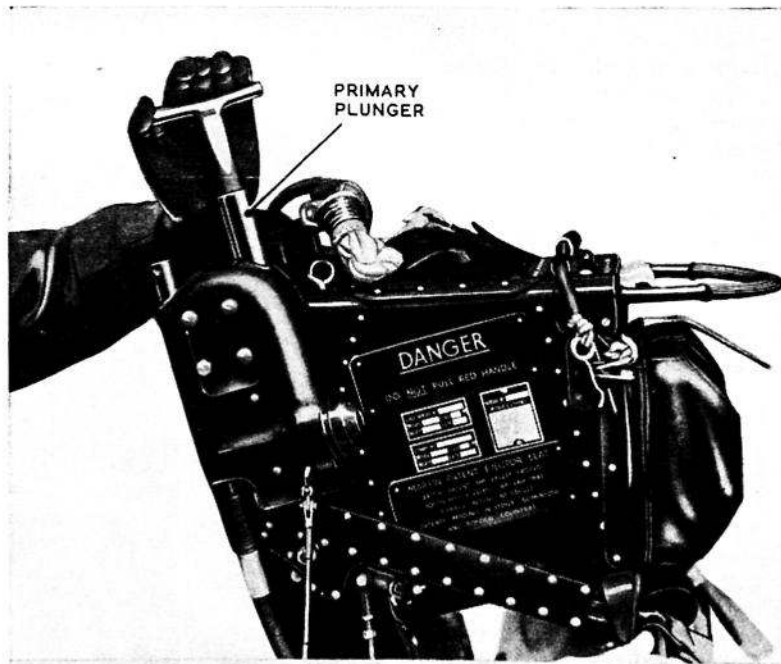

Fig. 20. Re-setting the barostatic time-release mechanism

- withdrawal line must emerge from the protective sleeve in the right-hand compartment.
- (5) Fold the 5 ft. drogue withdrawal line and the 18 in. drogue shroud lines on top of the protective sleeve in the right-hand compartment and stow the 18 in. drogue as shown in the lower diagram of fig. 22.
  - (6) Close the flaps in the following order:—port (1), starboard (2) rear (3) and front (4). The wire loop must pass through each eyelet in turn and the 18 in. drogue withdrawal line must emerge from the rearmost corner nearest the drogue gun.
  - (7) Insert the flap securing pin attached to the 18 in. drogue withdrawal line through the wire

RESTRICTED

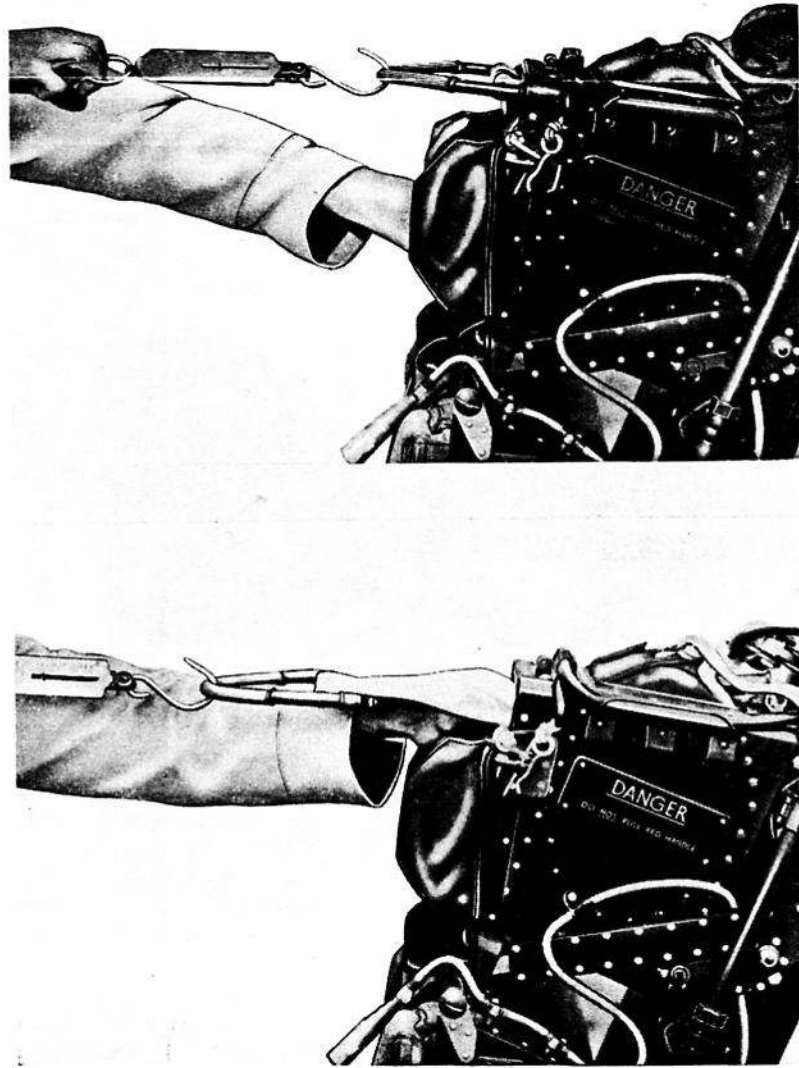

Fig. 21. Testing the face screen

loop and tie to the fabric loop on the front flap with a single loop of No. 8 linen thread (Stores Ref. 15A/108).

**Fitting the secondary cartridges**

33. (1) Insert each secondary cartridge into its housing and replace each cartridge cover; tighten all four covers with the special spanner.
- (2) Lock each cover with a length of 20 S.W.G. non-corrodible steel locking wire and seal, using a lead seal (Patt. No. B.11/3634) and the special pliers.

**Fitting the ejection gun in the guide rail**

34. Carefully insert the ejection gun into the guide rail, taking care not to damage the cylinder tube by allowing it to strike the walls of the guide rail. Rotate the gun through 90 deg. to bring the secondary cartridge housing into the lightening hole opposite the cover plate. Pull out the bottom latch and press the gun home.

**Note . . .**

*The ejection gun is to be examined for correct locking of the piston tube to the cylinder tube immediately prior to, and after, assembly in the guide rail. In addition, a physical check is to be conducted to ensure that the ejection gun itself is securely anchored in the guide rail.*

**Installing the seat in the aircraft**

35. (1) Carefully place the seat over the guide rail, register the rollers in the guides and lower the seat until the top latch engages.
- (2) Insert the safety pin (fig. 5).
- (3) Connect the time-release unit static line by inserting the quick-release pin.
- (4) Connect the intercom. lead and the main and emergency oxygen connections.
- (5) Push the scissor shackle forward into the horizontal position.

(A.L.26, Feb. 57)

**RESTRICTED**

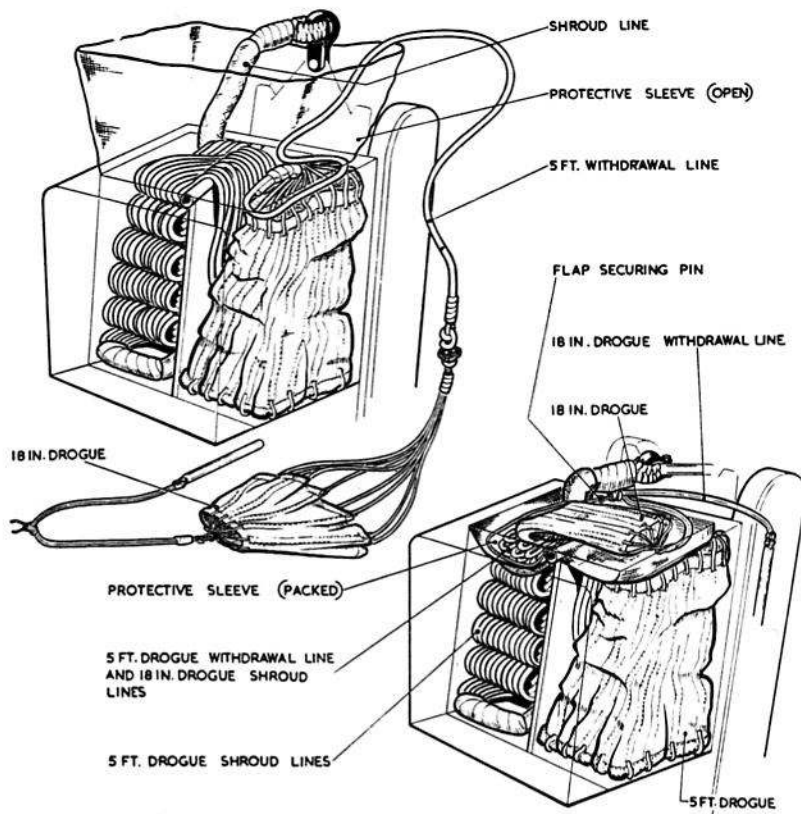

Fig. 22. Stowing the drogues

**IMPORTANT . . .**

Obstruction to closing of the hood (accompanied by hood damage) will occur if the scissor shackle is left in the vertical position. The embodiment of Mod. No. Ejection Seat 163 and 204 tend to retain the scissor shackle in the vertical position after it is used for lowering the seat in the aircraft. It is essential therefore for the shackle to be horizontal before lowering the hood.

**Fitting the drogue gun**

36. (1) Assemble the drogue gun in the quick-release clamps.
- (2) Connect the static line and drogue withdrawal line.

**Fitting the primary cartridge**

37. (1) Insert the cartridge spring into the breech.
- (2) Insert the primary cartridge and press it into the breech with the firing body until the thread engages.

- (3) Screw in the firing body as far as possible by hand and tighten with the combination spanner.
- (4) Lock with new 20 S.W.G. non-corrodible steel locking wire and seal with a lead seal (Patt. No. B.11/3634) using the special pliers.

**Note . . .**

Before sealing, cut the ends of the locking wire short and make certain that the loose ends of wire have been removed, otherwise subsequently they may prevent the seat structure being dropped right home and the latch engaging.

- (5) Insert the safety pin in the hole in the sear.
- (6) Connect the firing cable to the sear, ensuring that it passes through the legs of the scissor shackle.

**Note . . .**

When aircraft servicing is completed, transfer the safety pin from the hole in the sear to the face screen lock.

**RESTRICTED**

This file was downloaded  
from the RTFM Library.  
Link: [www.scottbouch.com/rtfm](http://www.scottbouch.com/rtfm)  
Please see site for usage terms,  
and more aircraft documents.

