

Chapter I

GENERAL DESCRIPTION AND OPERATING INSTRUCTIONS

LIST OF CONTENTS

	Para.		Para.
General	1	Quick-release connections	14
Description	2	Manual over-ride instructions	15
Operating instructions	9	Safety precautions	16
Sequence of operations	10		

LIST OF ILLUSTRATIONS

	Fig.		Fig.
Mk. 4A ejection seat	1	Parachute restraining strap	3
Leg restraining device	2	Action of scissor shackle	4

General

1. The Mk. 4A/1 ejection seat (Pilot) and the Mk. 4A/2 seat (Observer) are basically similar and differ principally in the ejection gun mounting and the length of the leg restraining straps. Additionally the Observer's seat embodies an angle mechanism which automatically projects the seat and occupant forward to the correct ejection angle when the canopy is jettisoned. Fully automatic facilities are provided to separate the occupant from the seat and to open his parachute after ejection.

Description

2. The seat structure complete with seat pan slides during ejection on four runners in a guide rail which is integral with the ejection gun.

3. The ejection gun is fired by the action of pulling out a large horizontal handle (coloured red) which projects from the front of the drogue container (*fig. 1*). This handle draws from the container a flexible screen which covers the occupant's face and protects it from the effects of the airstream. It also holds his head back and prevents it from jerking forward during ejection. Attached to the screen is a cable which is connected to a sear in the firing body of the ejection gun. When the screen is pulled right down over the face, the cable withdraws the sear and the gun is fired.

4. The seat pan accommodates a personal survival pack containing a dinghy, and can be adjusted for height by operating a handle on the starboard side of the seat structure. The seat pan moves relative to the headrest and can thus accommodate different body lengths, at the same time ensuring that the occupant's head is always correctly located whatever the position of the seat pan.

5. A leg restraining device (*fig. 2*) is incorporated to ensure that the occupant's legs are drawn back automatically and restrained close to the seat pan with the knees approximately 6 in. apart. This

device provides leg clearance during ejection and also prevents injury from the legs being blown apart by the airstream after ejection.

6. A Mk. 18A parachute assembly is supported on a bracket situated immediately below the headrest. The parachute assembly is shaped like a horseshoe and is held in position by a restraining strap (*fig. 3*). A back pad and seat cushion are attached to the parachute harness, which also embodies two quick-release cords for the personal survival pack which is fitted outside the parachute harness. The object of this arrangement is to enable the escapee to free the survival pack during the parachute descent when he is nearing the ground or water. After the pack has been freed from the parachute harness, a 20 ft. length of nylon cord pulls free from the pockets into which it is stowed and the descent is completed with the personal survival pack suspended approximately 20 ft. below the escapee.

7. The tops of the safety harness shoulder straps terminate in a specially shaped D-ring which is retained by a locking plunger and freed at the appointed time by the barostatic time-release unit; the harness may be freed manually as necessary by operating the lever on the port side of the seat pan. If the occupant wishes to lean forward for any purpose, he loosens the harness shoulder straps.

8. The automatic system is governed by the barostatic time-release unit which controls both the opening of a scissor shackle at the top of the seat structure and the operation of the safety harness locking plunger.

Operating instructions

9. The process of ejection from the aircraft is quite simple and consists of three distinct operations as follows:—

- (1) Jettison the cockpit canopy. (The canopy is interconnected with the Observer's angle mechanism and, in addition, the safety pins

(A.L.20, May 56)

RESTRICTED

RESTRICTED

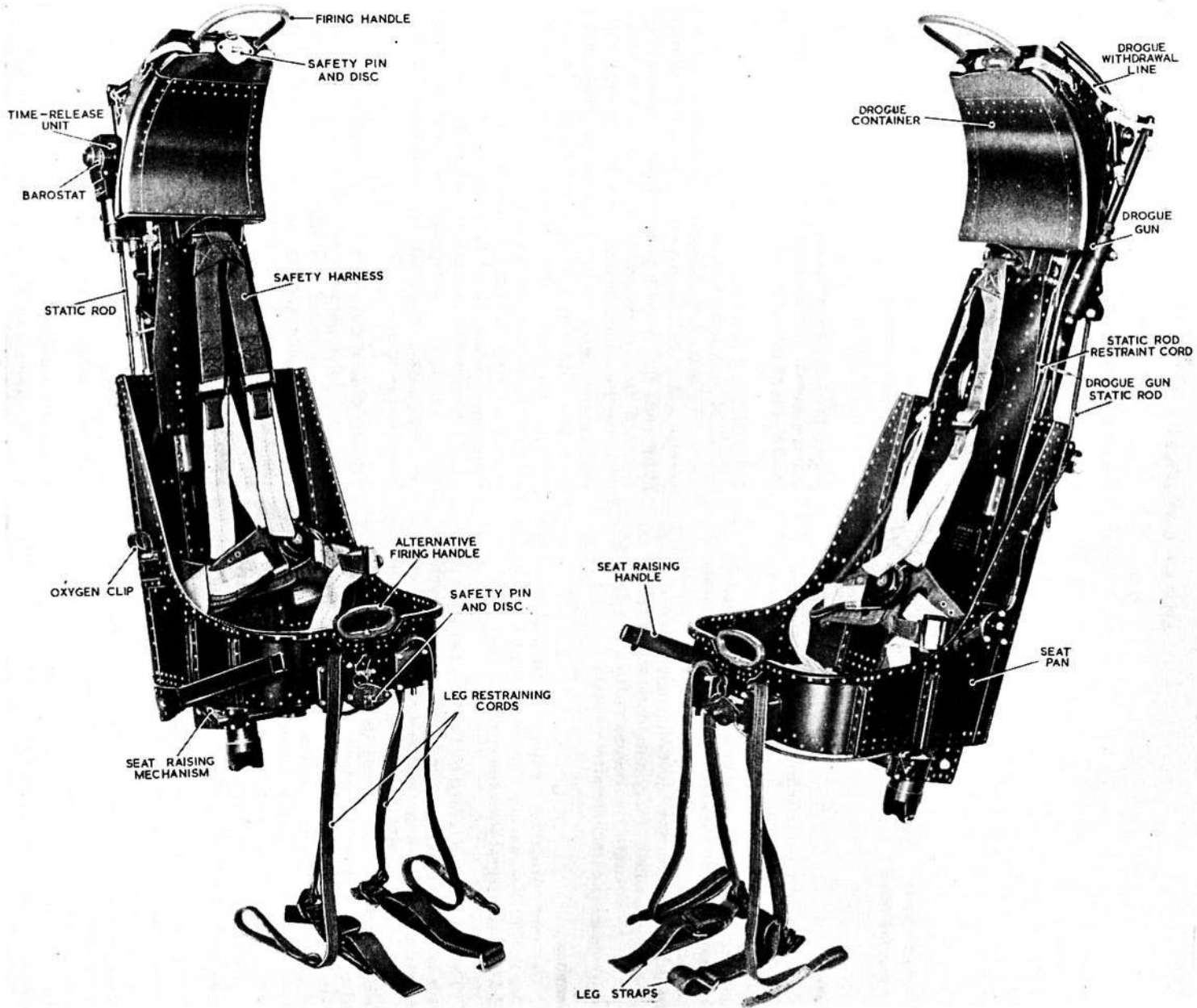

Fig. 1. Mk. 4A ejection seat

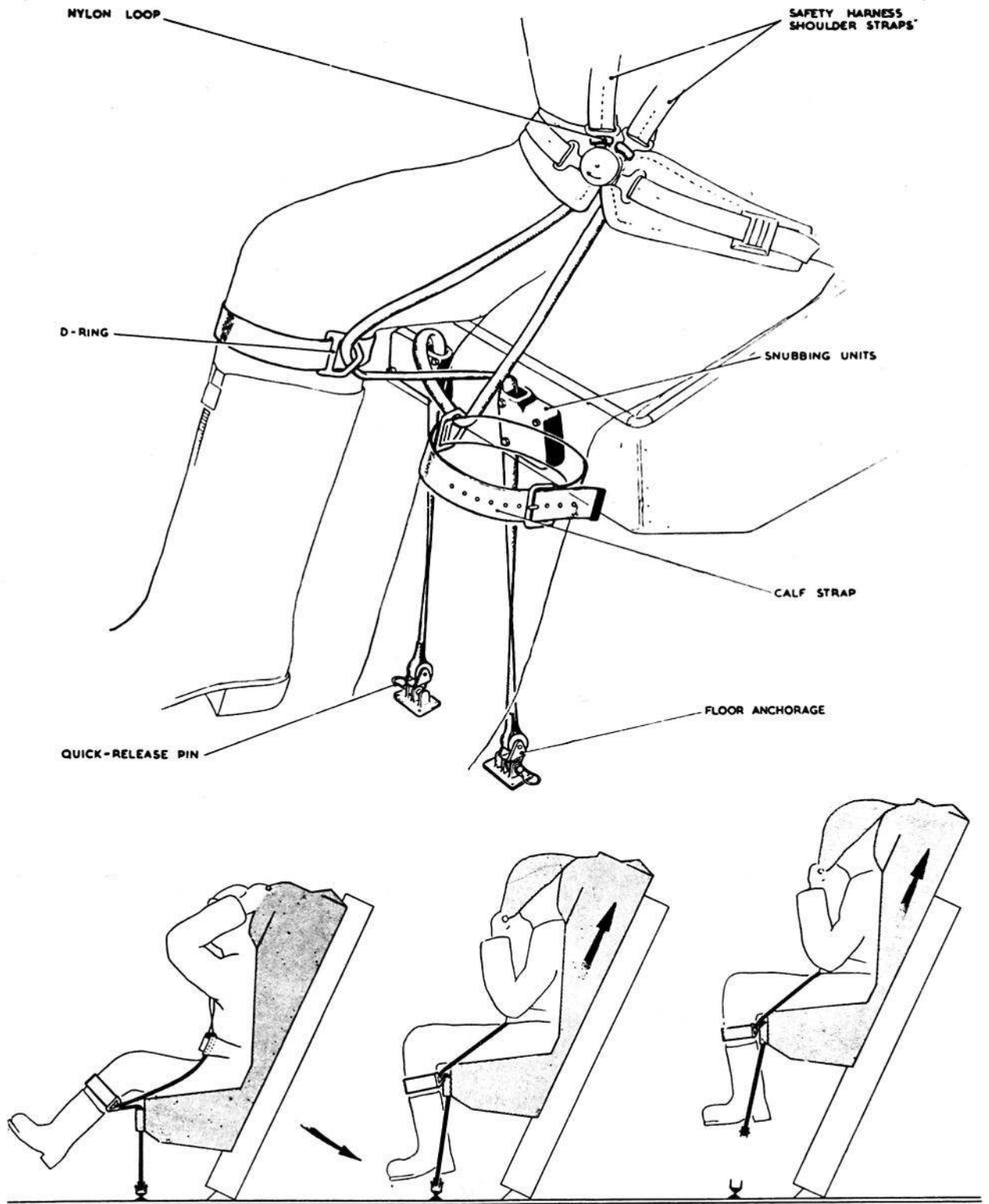

Fig. 2. Leg restraining device

RESTRICTED

which are withdrawn automatically from the ejection gun sears).

- (2) Withdraw the feet from the rudder pedals and at the same time grasp the firing handle. (The movements of the feet and hands in this action should be made simultaneously. Both hands must grasp the firing handle firmly, with the knuckles facing forward and the elbows close to the body. This ensures that the elbows will not contact the cockpit sides and that the chest will be protected against the airstream by the forearms).
- (3) Pull the firing handle with the face screen firmly right down over the face, keeping the head hard back against the headrest. This action fires the gun and ejection occurs immediately. (As the firing of the cartridge is unaffected by the speed of the movement, do not jerk the handle or pull it outwards away from the face. The hands must be kept close to the chest throughout the movement).

Alternative procedure. If it is not possible to reach the main firing handle in conditions of high 'g' press the head hard back against the headrest and pull upwards on the alternative firing handle on the seat pan. *It cannot be too strongly stressed that it is vital to keep the head hard back to the headrest, otherwise severe injury or worse will result.* It is pointed out that one of the principle advantages of the face screen is lost when using the alternative firing handle.

Sequence of operations

10. As the seat ascends the guide rail, two static rods come into operation: one controls the drogue gun time-delay mechanism and the other the barostatic time-release unit. After 0.5 sec. delay the drogue gun fires and extracts the duplex drogue.

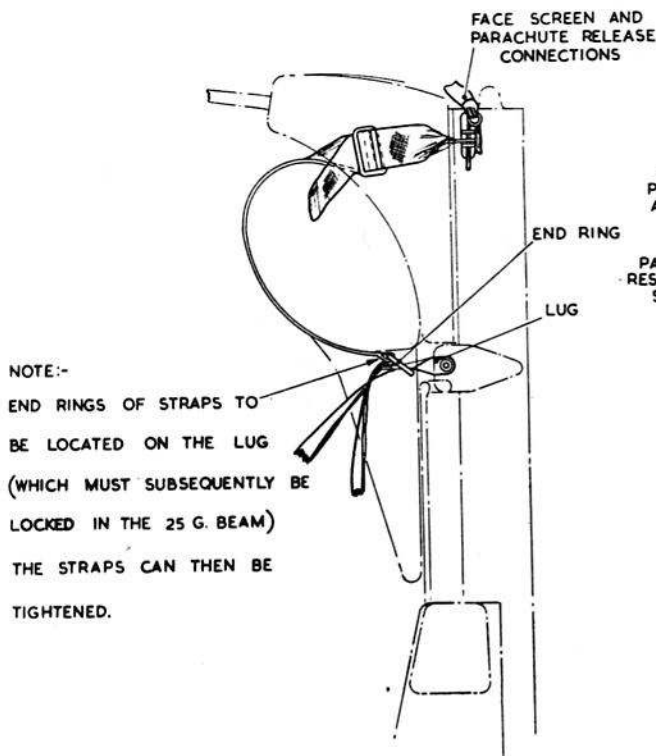

Fig. 3. Parachute restraining strap

11. For the purpose of description, it is assumed that ejection has taken place above 10,000 ft. The drogues first check the forward speed of the seat and then stabilize it in a slightly forward attitude.

12. At approximately 10,000 ft., the barostat removes an obstruction to a gear train which then commences to operate. After 3 sec. delay, the safety harness is released, the scissor shackle opens (fig. 4) and releases the drogue withdrawal line. The resultant pull of the drogues withdraws the retaining pins, so releasing the face screen and firing handle. The parachute withdrawal line pulls taut, opens the parachute, pulls the occupant clear and so allows the seat to fall freely.

13. At any convenient altitude after the parachute has developed fully, the occupant pulls the quick-release cords to free the personal survival pack. This reduces oscillation and lessens the likelihood of injury occurring on impact with the ground or water.

Quick-release connections

14. When the seat is ejected, the aircraft oxygen and intercom. services disengage automatically at quick-release connections. Further quick-release connections are provided for disengaging these services when the occupant leaves the seat subsequent to ejection. Further connections are also provided for the emergency oxygen system: one to operate the emergency oxygen bottle on ejection and then to disengage, and another to enable the oxygen mask to be disconnected from the oxygen bottle; the latter action is not automatic.

Manual over-ride instructions

15. If for any reason the automatic system fails to function, proceed as follows:—

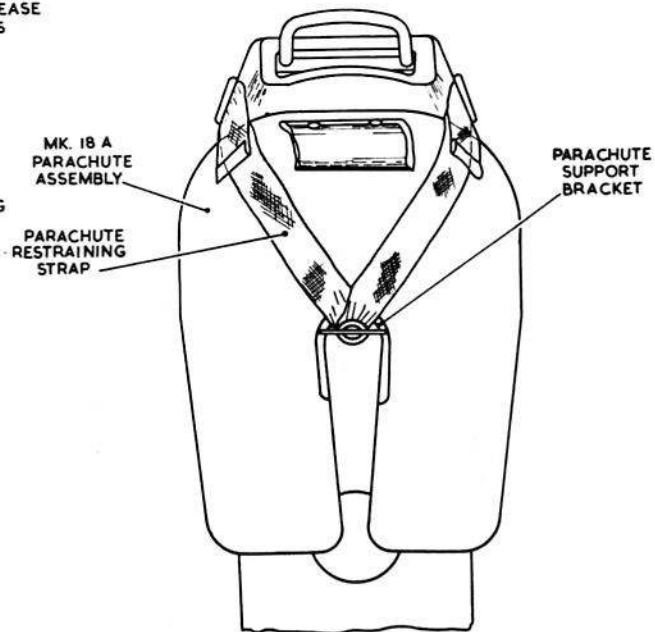

RESTRICTED

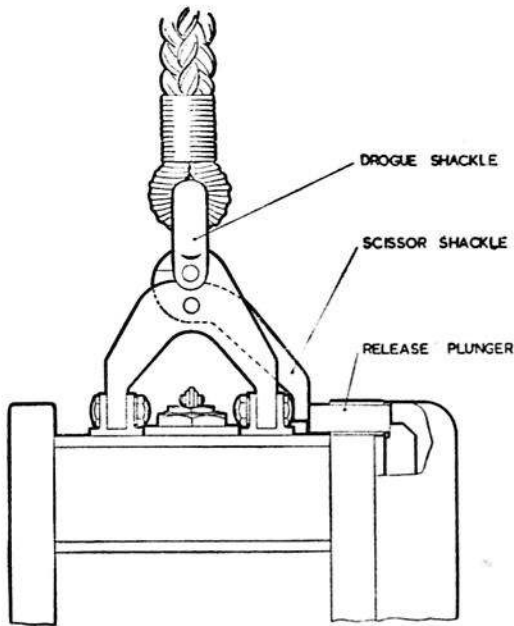

Fig. 4. Action of scissor shackle

- (1) After the forward speed has been checked by the drogues, discard the firing handle and face screen and pull the outer over-ride D-ring on the parachute harness. This isolates the automatic parachute opening device.
- (2) At a safe altitude, operate the manual over-ride lever on the port side of the seat to unlock the parachute and seat harness.
- (3) When clear of the seat, pull the inner D-ring to make a normal parachute descent.

IMPORTANT . . .

It is vital to concentrate all the faculties on operating the manual over-ride and releasing the safety harness; the seat will probably be spinning and the occupant therefore confused.

Safety precautions

16. A fabric strap is attached to the front edge of the drogue container. When this handle is passed through the firing handle and locked by the safety pin provided, the face screen is locked against the possibility of withdrawal; a red warning disc is attached to the safety pin. A similar strap and pin locks the alternative firing handle on the seat pan.

17. The static rods permit a limited amount of movement before their associated mechanisms are operated, and an elastic cord restrains the rods to the seat structure to prevent their fouling any part of the aircraft structure.

18. Unlike the conventional ejection seat, the Mk. 4A seat always has a safety pin in the ejection gun sear during flight. This ensures that the seat cannot be inadvertently operated before the canopy is jettisoned (since they are interconnected).

19. Before entering the cockpit, or before any work is commenced in the cockpit or on the seat, the safety precautions given in the Introduction to this section must be obeyed implicitly.

20. The alternative firing handle safety pin and disc must be removed before flight. Before attempting to leave the seat, the pilot and observer must each ensure that the safety pin is inserted in their respective alternative firing handle locks.

RESTRICTED

(A.L.25, Nov. 56)



This file was downloaded
from the RTFM Library.
Link: www.scottbouch.com/rtfm

Please see site for usage terms,
and more aircraft documents.

