

WING ARRANGEMENT

Ref. No.	Part No.	Nomenclature						No Off	M.R.	Cl. of St.	Plate No.
		1	2	3	4	5	6				
	—	<b>WING ARRANGEMENT, PORT</b> ... ..						1	—		B.1
	—	<b>WING ARRANGEMENT, STARBOARD</b> ... ..						1	—		B.1
9773	12 WA 1159A/4	<b>AILERON</b> , complete with tab, port ... .. (See Separate Unit)						1	—	A.	BA.1
9774	12 WA 1160A/3	<b>AILERON</b> , complete with tab, starboard ... .. (See Separate Unit)						1	—	A.	BA.1
		Attaching parts for 12 WA 1159A/4 and 12 WA 1160A/3, Ailerons :—									
131	12 W 1351	Bolt, centre hinge ... ..						1	—	C.	B.2
28D/13366	A30/23G	Bolt, inner hinge ... ..						2	—	C.	
132	12 W 1353	Bolt, outer hinge ... ..						1	—	C.	B.2
133	12 W 1939	Nut, centre and outer hinge ... ..						2	—	C.	B.2
28M/14537	A58/GS	Nut, $\frac{5}{16}$ " BSF, inner hinge ... ..						1	—	C.	
28P/12462	SP9/C8	Pin, split ... ..						3	—	C.	B.2
28W/12324	SP.15/G	Washer, centre and outer hinges ... ..						2	—	C.	B.2
28W/12254	SP.13/G	Washer, inner hinge ... ..						1	—	C.	
944	12 S 587	<b>BLOCK</b> , clamp, half, for hydraulic pipes from fireproof bulkhead						4	M.R.	C.	
		Attaching parts for 12 S 587, Block (per pair) :—									
28D/12533	A25/5C	Bolt, 2 BA ... ..						2	M.R.	C.	
28M/10288	AGS.2001/C/1	Nut, 2 BA ... ..						2	M.R.	C.	
28W/12252	SP.13/C	Washer ... ..						2	M.R.	C.	
28E/14078	AS.3181/4C	<b>CLIP</b> , tubular, for brake pipe at clamp block aft of fireproof bulkhead						2	M.R.	C.	
752	12 W 1513	<b>FILLET</b> , root, front, Port ... ..						1	—	C.	B.2
753	12 W 1514	<b>FILLET</b> , root, front, Starboard ... ..						1	—	C.	B.2
		Attaching parts for 12 W 1513 and 12 W 1514, Fillets :—									
28D/8306	AS.1242/1C	Bolt, 2 BA ... ..						17	—	C.	
8164	12 W 3845ND	<b>FILLET</b> , root, top, Port ... ..						1	M.R.	C.	B.2
8165	12 W 3846ND	<b>FILLET</b> , root, top, Starboard ... ..						1	M.R.	C.	B.2
		Attaching parts for 12 W 3845ND and 12 W 3846ND, Fillets :—									
28D/8306	AS.1242/1C	Bolt, 2 BA ... ..						33	M.R.	C.	
8166	12 W 3847ND	<b>FILLET</b> , root, bottom, Port ... ..						1	M.R.	C.	B.2
8167	12 W 3848ND	<b>FILLET</b> , root, bottom, Starboard ... ..						1	M.R.	C.	B.2
		Attaching parts for 12 W 3847ND and 12 W 3848ND, Fillets :—									
28D/8306	AS.1242/1C	Bolt, 2 BA ... ..						13	M.R.	C.	
5	12 WB 1A	<b>FLAP</b> , dive brake, Port ... ..						1	—	A.	B.3
6	12 WB 2A	<b>FLAP</b> , dive brake, Starboard ... ..						1	—	A.	B.3
27S/141	I.132895	<b>BEARING</b> , ball-race, Skefko, for inner hinge ... ..						1	—	B.	
5866	12 WB 47A	<b>BRACKET</b> , bearing, outer hinge, Port ... ..						1	M.R.	B.	B.3
5867	12 WB 48A	<b>BRACKET</b> , bearing, outer hinge, Starboard ... ..						1	M.R.	B.	B.3
27S/143	CD. $\frac{5}{16}$ "/B	<b>BEARING</b> , ball-race, Ransome and Marles ... ..						1	—	B.	
7142	12 WB 49ND	<b>BRACKET</b> , outer hinge, Port ... ..						1	M.R.	C.	B.3
7143	12 WB 50ND	<b>BRACKET</b> , outer hinge, Starboard ... ..						1	M.R.	C.	B.3

WING ARRANGEMENT

Ref. No.	Part No.	Nomenclature						No. Off	M.R.	Cl. of St.	Plate No.
		1	2	3	4	5	6				
28N/12447	AGS.2030/21	<b>CIRCLIP</b> , internal ... .. Attaching parts for 12 WB 47A and 12 WB 48A, Brackets :—						1	—	C.	
28D/12533	A25/5C	Bolt, 2 BA ... ..						4	M.R.	C.	
28N/12557	AGS.2030/39	<b>CIRCLIP</b> , internal, for retaining inner hinge ball- race bearing Attaching parts for 12 WB 1A and 12 WB 2A, Flaps :—						1	—	C.	
197	12 W 1009	Block, outer hinge, Port ... ..						1	—	C.	B.3
198	12 W 1010	Block, outer hinge, Starboard ... ..						1	—	C.	B.3
200	12 W 3089	Bolt, inner hinge ... ..						1	—	C.	B.3
28D/12821	A25/14G	Bolt, $\frac{5}{16}$ " BSF, at hinge pin block ... ..						2	—	C.	
28M/13267	A.24/GS	Nut, $\frac{5}{16}$ " BSF ... ..						3	—	C.	
199	12 W 1011	Pin, outer hinge ... ..						1	—	C.	B.3
28P/12462	SP.9/C.8	Pin, split ... ..						3	—	C.	
28W/12324	SP.15/G	Washer ... ..						3	—	C.	
10984	12 WF 245A/1	<b>FLAP</b> , inner, Port (Mod. Ven. 821)... .. Consisting of :—						1	—	C.	
	12 WF 277A/ND	<b>FLAP</b> , inner, Port (less 12 WF 253A Plate) ...						1	—	C.	
10494	12 WF 217	<b>BRACKET</b> , for torque link, flap hinge rib No. 5 Attaching parts for 12 WF 217, Bracket :—						1	—	C.	
28D/12531	A25/3C	Bolt, 2 BA ... ..						3	—	C.	
28D/9436	AS.1242/8G	Bolt, $\frac{5}{16}$ " BSF ... ..						1	—	C.	
28M/10327	AGS.2002/B/1	Nut, 4 BA ... ..						2	—	C.	
28M/12929	A27/CP	Nut, 2 BA ... ..						3	—	C.	
28M/13375	A27/GP	Nut, $\frac{5}{16}$ " BSF ... ..						1	—	C.	
	12 WF 225ND	Packing, 2-20" x .50", L.72, 16 SWG (Make from 30B/1728)						1	—	C.	
28S/2809	A33/B12	Screw, 4 BA ... ..						2	—	C.	
	12 WF 223ND	Washer, .50" x .45" x 18 SWG, L.72 (Make from 30B/1730)						3	—	C.	
28W/12324	SP.15/G	Washer, $\frac{5}{16}$ " BSF ... ..						1	—	C.	
10498	12 WF 233	<b>FAIRING</b> , for torque link flap hinge, rib No. 5 Attaching parts for 12 WF 233, Fairing :—						1	—	C.	
28S/2869	A32/B20	Screw, 4 BA ... ..						4	—	C.	
	12 WF 3A/2	<b>FLAP</b> , inner position, Port ... ..						1	—	C.	
	12 WF 263A/ND	<b>FLAP</b> (Less 12 WF 191A/ND Ninge) ...						1	—	C.	
27S/142	I.132498	<b>BEARING</b> , ball-race, inner hinge ...						1	—	B.	
28N/12447	AGS.2030/21	<b>CIRCLIP</b> , retaining ball-race bearing ...						1	—	C.	
	12 WF 247	<b>HINGE</b> , flap, rib No. 5 ... ..						1	—	C.	
10493	12 WF 227	<b>SPINDLE</b> , bolt, flap torque link ...						1	M.R.	C.	
		Attaching parts for 12 WF 227, Spindle :—									
28M/12928	A27/EP	Nut, $\frac{1}{4}$ " BSF ... ..						1	—	C.	
28W/12496	SP.15/E	Washer ... ..						1	—	C.	



WING ARRANGEMENT

Ref. No.	Part No.	Nomenclature						No. Off	M.R.	Cl. of St.	Plate No.
		1	2	3	4	5	6				
10493	12WF 227										
28M/12928	A27/EP										
28W/12496	SP.15/E										
10121	12-20 WF 523ND										
8335	12 WF 191A/ND										
27S/143	CD. $\frac{3}{8}$ " /B										
213	12 WF 15										
28D/12513	A25/2C										
28D/12533	A25/5C										
28M/10288	AGS 2001/C/1										
28W/12252	SP 13/C										
28M/12447	AGS 2030/21										
11671	12 WF 254A										
	12 WF 258ND										
	12 WF 209ND										
28D/8337	AS.1248/1B										
28D/8306	AS.1242/1C										
28L/13140	A27/BT										
28M/12929	A27/CP										
10986	12 WF 243A/1										
	12 WF 279A/ND										
10496	12 WF 219										
28D/12531	A25/3C										
28D/9436	AS.1242/8G										
28M/10327	AGS.2002/B/1										
28M/12929	A27/CP										
28M/13375	A27/GP										
28S/2809	A33/B12										
28W/12296	SP.15/C										
28W/12324	SP.15/G										
10498	12 WF 233										
28S/2869	A32/B20										

WING ARRANGEMENT

Ref. No.	Part No.	Nomenclature						No. Off	M.R.	Cl. of St.	Plate No.
		1	2	3	4	5	6				
27S/144 28N/12353	12 WF 5A/2							1	—		
	12 WF 261A/ND							—	—		
214	SKF.CBA.3							1	—	B.	
	AGS.2030/45							1	—	C.	
28M/12928	12 WF 249							1	—		
	12 WF 49							1	M.R.	C.	
28W/12496	A27/EP							1	—	C.	
	SP.15/E							1	—	C.	
28W/12352	SP.10/E							1	—	C.	
8335 27S/143	12 WF 191A/ND							1	M.R.	B.	
	CD. $\frac{5}{16}$ " B							1	—	B.	
213	12 WF 15							1	M.R.	C.	
28D/12513	A25/2C							2	—	C.	
	A25/5C							2	—	C.	
28M/10288	AGS.2001/C/1							2	—	C.	
	SP.13/C							2	—	C.	
28N/12447	AGS.2030/21							1	—	C.	
11672	12 WF 255A							1	—	C.	
	12 WF 259ND							1	—	C.	
28D/8337	AS.1248/1B							1	—	C.	
	AS.1242/1C							23	—	C.	
28L/13140	A27/BT							1	—	C.	
28M/12929	A27/CP							21	—	C.	
10987	12 WF 244A/1							1	—	C.	
10497	12 WF 280A/ND							1	—		
	12 WF 220							1	—	C.	
28D/12532	A25/4C							2	—	C.	
	AS.1242/14G							1	—	C.	
28M/10327	AGS.2002/B/1							2	—	C.	
28M/12929	A27/CP							2	—	C.	
28M/13375	A27/GP							1	—	C.	
28S/2809	A33/B12							2	—	C.	
28W/12296	SP15/C							1	—	C.	
28W/12324	SP15/G							2	—	C.	
10498	12 WF 233							1	—	C.	
28S/2869	A32/B20							3	—	C.	

WING ARRANGEMENT

Ref. No.	Part No.	Nomenclature						No. Off	M.R.	Cl. of St.	Plate No.
		1	2	3	4	5	6				
27S/144 28N/12353	12 WF 6A/2							1	—		
	12 WF 262A/ND							1	—		
214	SKF.CBA.3							1	—	B.	
	AGS.2030/45							1	—	C.	
28M/12928 28W/12496 28W/12352	12 WF 250							1	—		
	12 WF 49							1	M.R.	C.	
8335 27S/143 213	A27/EP							1	—	C.	
	SP.15/E							1	—	C.	
28D/12513 28D/12533 28M/10288 28W/12252	SP.10/E							1	—	C.	
	12 WF 191A/ND							1	M.R.	B.	
28D/12513 28D/12533 28M/10288 28W/12252	CD. $\frac{5}{16}$ "/B							1	—	B.	
	12 WF 15							1	M.R.	C.	
28D/12513 28D/12533 28M/10288 28W/12252	A25/2C							2	M.R.	C.	
	A25/5C							2	M.R.	C.	
28N/12447	AGS.2001/C/1							2	M.R.	C.	
	SP13/C							2	M.R.	C.	
11673	AGS.2030/21							1	—	C.	
	12 WF 256A							1	—		
28D/8337 28D/8306 28L/13140 28M/12929	12 WF 260ND							1	—		
	12 WF 207ND							1	—		
28D/8337 28D/8306 28L/13140 28M/12929	AS.1248/1B							1	—	C.	
	AS.1242/1C							23	—	C.	
28P/12462 28W/12253 28W/12254	A27/BT							1	—	C.	
	A27/CP							21	—	C.	
211 210	12 WF 245A/1, 12 WF 246A/1, 12 WF 243A/1, 12 WF 244A/1, Flaps :-							2	—	C.	
	12 WF 105							1	—	C.	
28M/12930 28M/13122	12 WF 103							1	—	C.	
	A27/ES							3	—	C.	
212 28P/12462 28W/12253 28W/12254	A27/GS							1	—	C.	
	12 W 2847							1	—	C.	
532 539	SP.9/C8							4	—	C.	
	SP.13/E							3	—	C.	
536 530 537	SP.13/G							1	—	C.	
	12 S 485A/ND							1	—	C.	B.2
531 538	12 S 513A/ND							1	—	C.	B.2
	12 S 481A/ND							1	—	C.	B.2
529 536	12 S 509A/ND							1	—	C.	B.2
	12 S 473A/ND							1	—	C.	B.2
530 537	12 S 501A/ND							1	—	C.	B.2
	12 S 477A/ND							1	—	C.	B.2
527	12 S 505A/ND							1	—	C.	B.2
	12 S 465A/ND							1	—	C.	B.2

AEROFOILS

WING ARRANGEMENT

Ref. No.	Part No.	Nomenclature						No. Off	M.R.	Cl. of St.	Plate No.
		1	2	3	4	5	6				
534	12 S 493A/ND	PIPE, undercarriage down, from fireproof bulkhead to rib No. 1, Starboard						1	—	C.	B.2
528	12 S 469A/ND	PIPE, undercarriage up, from fireproof bulkhead to rib No. 1, Port						1	—	C.	B.2
535	12 S 497A/ND	PIPE, undercarriage up, from fireproof bulkhead to rib No. 1, Starboard						1	—	C.	B.2
533	12 S 489A/ND	PIPE, brake, from fireproof bulkhead to rib No 1, Port...						1	—	C.	B.2
540	12 S 517A/ND	PIPE, brake, from fireproof bulkhead to rib No. 1, Starboard						1	—	C.	B.2
	12 4W 3A/28	WING, PORT (See Separate Unit) (Mod. Ven. 821) (Pre Mod. Ven. 983)						1	—	A.	B.1
	12 4W 4A/29	WING, STARBOARD (See Separate Unit) ... (Mod. Ven. 821) (Pre Mod. Ven. 983)						1	—	A.	B.1
	12-4W 3A/29	WING, Port (See separate unit) (Mod. Ven. 983) (Pre Mod. Ven. 994)						1	—	A.	BB.1
	12-4W 4A/30	WING, Starboard (See separate unit) (Mod. Ven. 983) (Pre Mod. Ven. 994)						1	—	A.	BB.1
	12 4W 3A/30	WING, PORT (See Separate Unit) (Mod. Ven. 994) (Pre Mod. Ven. 575)						1	—	A.	BB.1
	12 4W 4A/31	WING, STARBOARD (See Separate Unit) ... (Mod. Ven. 994) (Pre Mod. Ven. 575)						1	—	A.	BB.1
	12 4W 4A/32	WING, STARBOARD (See Separate Unit)... ... (Mod. Ven. 994) (Pre Mod. Ven. 575) (Mod. Ven. 352)						1	—	A.	BB.1
	12 4W 23A/ND	WING, PORT, ONLY (See Separate Unit) ... (Mod. 235) (S.O.O.)						1	—	A.	BB.1
	12 4W 17A	WING, PORT (See Separate Unit) ... (Mod. Ven. 575) (Pre Mod. Ven. 983)						1	—	A.	BB.1
	12 4W 19A	WING, STARBOARD (See Separate Unit) ... (Mod. Ven 575) (Pre Mod. Ven. 983)						1	—	A.	BB.1
	12 4W 17A/1	WING, PORT (See Separate Unit) ... (Mod. Ven. 575) (Mod. Ven. 983)						1	—	A.	BB.1
	12 4W 19A/1	WING, STARBOARD (See Separate Unit) ... (Mod. Ven. 575) (Mod. Ven. 983)						1	—	A.	BB.1
	12 4W 17A/2	WING, PORT (See Separate Unit) ... (Mod. Ven. 575) (Mod. Ven. 983) (Mod. Ven. 994)						1	—	A.	BB.1
	12 4W 19A/2	WING, STARBOARD (See Separate Unit) ... (Mod. Ven. 575) (Mod. Ven. 983) (Mod. Ven. 994)						1	—	A.	BB.1
	12 4W 19A/3	WING, STARBOARD (See Separate Unit) ... (Mod. Ven. 575) (Mod. Ven. 983) (Mod. Ven. 994) (Mod. Ven. 352)						1	—	A.	BB.1

WING ARRANGEMENT

Ref. No.	Part No.	Nomenclature						No. Off	M.R.	Cl. of St.	Plate No.
		1	2	3	4	5	6				
	12 4W 27A/ND	<b>WING, PORT, ONLY</b> (See Separate Unit) ... (Mod. Ven. 575) (Mod. Ven. 983) (Mod. Ven. 235) (S.O.O.) Attaching parts for 12 4W 3A/28, 12 4W 4A/29, 12 4W 3A/30, 12 4W 4A/31, 12 4W 4A/32, 12 4W 23A/ND, 12 4W 17A, 12 4W 19A, 12 4W 17A/1, 12 4W 19A/1, 12 4W 17A/2, 12 4W 19A/2, 12 4W 19A/3, 12 4W 27A/ND, Wings :—						1	—	A.	BB.1
360	12 W 3025	Bolt, $\frac{7}{16}$ " 2-25" long shank, front ... ..						1	—	C.	B.2
1207	12 2W 125	Bolt, $\frac{3}{8}$ " BSF, bottom rear ... ..						1	—	C.	B.2
1204	12 2W 43	Bolt, $\frac{3}{8}$ " BSF, top rear ... ..						1	—	C.	B.2
11428	12 W 5949	Bolt, special, $\frac{7}{16}$ " BSF $\times$ .35" long, top and bottom rear (Mod. Ven. 943)						2	—	C.	
28M/13120	A27/LS	Nut, $\frac{7}{16}$ " BSF for front bolt ... ..						1	—	C.	
28P/12351	SP9/E8	Pin, split for front bolt ... ..						1	—	C.	
11431	12 W 6033A	Plate, locking, top rear (Mod. Ven. 943) ... ..						1	—	C.	
11432	12 W 6035A	Plate, locking, bottom rear (Mod. Ven. 943) ... ..						1	—	C.	
28W/12498	SP.16/L	Washer, for front bolt ... ..						1	—	C.	
11429	12 W 5953	Washer, top rear (Mod. Ven. 943) ... ..						1	—	C.	
11430	12 W 6043	Washer, bottom rear (Mod. Ven. 943) ... ..						1	—	C.	
11433	12 W 5951ND	Washer, top rear, .453" $\times$ .458" i/d. $\times$ 1.75" o/d. $\times$ 12 SWG, Spec. S.3 (Mod Ven. 943)						1	—	C.	
11434	12 W 6045ND	Washer, bottom rear, .453" $\times$ .458" i/d. $\times$ 1.5" o/d., 12 SWG, S,3 (Mod. Ven. 943)						1	—	C.	

AILERON

Ref. No.	Part No.	Nomenclature						No Off	M.R.	Cl. of St.	Plate No.
		1	2	3	4	5	6				
9773	12 WA 1159A/4	<b>AILERON</b> , complete with tab, Port (Mod. Ven. 704)...						1	—	A.	BA.1
9774	12 WA 1160A/3	<b>AILERON</b> , complete with tab, Starboard (Mod. Ven. 704)						1	—	A.	BA.1
3872	12 WA 13	<b>BRACKET</b> , centre hinge ... ..						1	MR	C.	BA.1
28D/12674	Z.25/9E 12 WA 123	Attaching parts for 12 WA 13, Bracket :— Bolt, 1/2" BSF ... ..						4	—	C.	
		Shim ... ..						1	—		BA.1
4741	12 WA 801A	<b>BRACKET</b> , inner hinge ... ..						1	—	B.	BA.1
27S/22	Hoffmann-U112/W	<b>BEARING</b> , ball-race ... ..						1	—	B.	
28N/12557	AGS.2030/39 12 WA 803ND	<b>CIRCLIP</b> , 32 m/m ... ..						1	—	C.	
		<b>HOUSING</b> , ball-race ... ..						1	—		BA.1
5899	12 WA 1015	Attaching parts for 12 W 801A, Bracket :— Bolt, special ... ..						1	—	C.	BA.1
28M/13123	A27/JS	Nut, 3/8" BSF ... ..						1	—	C.	
28P/12462	SP.9/C8	Pin, split ... ..						1	—	C.	
28W/12255	SP.13/J	Washer ... ..						1	—	C.	
8741	12 WA 1207ND	Washer, shim, .80" o/d x .50" i/d x .107" thick, Attewell steel or brass						1	—		
	12 WA 1205ND	Washer (Make from 28W/12699-SP.10/L) ... ..									
3873	12 WA 15	<b>BRACKET</b> , outer hinge ... ..						1	MR	C.	BA.1
28D/12519	A.25/3E	Attaching parts for 12 WA 15 Brackets :— Bolt, 1/2" BSF ... ..						2	—	C.	
5628	12 WA 121	Shim ... ..						1	MR	C.	BA.1
6515	12 WA 1097	<b>BRACKET</b> , trim tab, centre inner and outer hinges						3	—	C.	BA.1
28D/12512	A.25/1C	Attaching parts for 12 WA 1097, Bracket :— Bolt, 2 BA ... ..						2	—	C.	
28D/12513	A.25/2C	Bolt, 2 BA ... ..						4	—	C.	
28W/12296	SP.15/C	Washer ... ..						2	—	C.	
6514	12 WA 1095	<b>BRACKET</b> , trim tab, centre outboard hinge ...						1	—	C.	BA.1
28D/12531	A.25/3C	Attaching parts for 12 WA 1095, Bracket :— Bolt, 2 BA ... ..						2	—	C.	
28W/12296	SP.15/C	Washer ... ..						2	—	C.	
160	12 WA 141ND	<b>COVER</b> , centre hinge, Port ... ..						1	—	C.	BA.1
161	12 WA 142ND	<b>COVER</b> , centre hinge, Starboard ... ..						1	—	C.	BA.1
28D/8300	AS.1242/1B	Attaching parts for 12 WA 141ND and 12 WA 142ND, Covers :— Bolt, 4 BA ... ..						5	—	C.	
9771	12-4WA 25	<b>FAIRING</b> , tab, connecting rod at centre outboard hinge						1	—		BA.1
28D/8341	AS.1248/1C	Attaching parts for 12-4WA 25, Fairing :— Bolt, 2 BA ... ..						4	—	C.	
6516	12 WA 845A	<b>LEVER</b> , aileron operating at Rib No. 2, port ...						1	MR	B.	
6517	12 WA 846A	<b>LEVER</b> , aileron operating at Rib No. 2, starboard...						1	MR	B.	
156	12 WA 9A	<b>LINK</b> , centre hinge swivel ... ..						1	MR	B.	BA.1
155	12 WA 5A	<b>LINK</b> , outer hinge swivel ... ..						1	MR	B.	BA.1
27S/142	Skefko I.132498	<b>BEARING</b> , ball-race ... ..						1	—	B.	
158	12 WA 31	Attaching parts for 12 WA 9A and 12 WA 5A, Links :— Bolt ... ..						1	—	C.	BA.1
28M/13122	A.27/GS	Nut, 5/16" BSF ... ..						1	—	C.	
28P/12462	SP.9/C8	Pin, split ... ..						1	—	C.	
28W/12324	SP.15/G	Washer ... ..						1	—	C.	

AILERON

Ref. No.	Part No.	Nomenclature						No. Off	M.R.	Cl. of St.	Plate No.
		1	2	3	4	5	6				
9768 27S/34 28R/13504	12-4CF 27A Skefko I.132465 Ransome & Marles CM.3/16B	<b>ROD</b> , connecting, tab operating, Port ... ..						1	—	C.	BA.1
		<b>BEARING</b> , end ... ..						1	—	B.	
		<b>BEARING</b> , eye-end ... ..						1	—	A.	
28L/13028	A.27/JT	Attaching parts for CM.3/168, Bearing :— Locknut, $\frac{3}{8}$ " BSF... ..						1	—	C.	
28D/13880 28M/13121 28P/12462 28W/12252	AS.2504/9C A27/CS SP.9/C8 SP.13/C	Attaching parts for 12-4CF 27A, Rod :— Bolt, 2 BA ... ..						1	—	C.	
		Nut, 2 BA ... ..						2	—	C.	
		Pin, split ... ..						2	—	C.	
		Washer ... ..						1	—	C.	
9769 28R/13504	12-4CF 17A Ransome & Marles CM.3/16B	<b>ROD</b> , connecting, tab operating, Starboard ... ..						1	—	C.	BA.1
		<b>BEARING</b> , eye-end ... ..						1	—	A.	
		Attaching parts for CM.3/16B, Bearing :— Locknut, $\frac{3}{8}$ " BSF... ..						1	—	C.	
28L/13028	A27/JT	Attaching parts for 12-4CF 17A, Rod :— Bolt, 2 BA ... ..						1	—	C.	
27S/139	Skefko CBA.0	<b>BEARING</b> , end ... ..						1	—	B.	
28D/13880 28D/12170 9770 28M/13121 28P/12462 28W/12252 28W/12355 4733	AS.2504/9C AS.2504/11C 12-4CF 21 A27/CS SP.9/C8 SP.13/C SP.16/C 12 CF 943	Attaching parts for 12-4CF 17A, Rod :— Bolt, 2 BA ... ..						1	—	C.	
		Bolt, 2 BA ... ..						1	—	C.	
		Bush ... ..						2	—	C.	BA.1
		Nut, 2 BA ... ..						2	—	C.	
		Pin, split ... ..						2	—	C.	
		Washer ... ..						1	—	C.	
		Washer ... ..						1	—	C.	
		Washer, serrated ... ..						1	—	C.	BA.1
9777	12 WA 1085A/2	<b>TAB</b> , port ... ..						1	—		BA.1
9778	12 WA 1086A/2	<b>TAB</b> , starboard ... ..						1	—		BA.1
8510	12 WA 1209A	<b>BRACKET</b> , hinge, centre outboard, (master hinge)						1	—	C.	BA.1
8511	12 WA 1211	<b>BRACKET</b> ... ..						1	—	C.	BA.1
	12 WA 1107	<b>BUSH</b> ... ..						1	—		BA.1
4637	15 FC 2053	<b>CIRCLIP</b> , internal, (may be made from A.M. Ref. No. 28N/12845 - AGS.2030/9)						1	—	C.	BA.1
28N/13511	Hoffmann CJ.1	<b>JOINT</b> , self-aligning ... ..						1	—	C.	
28D/13107 28D/13401 28W/12245	A30/3C A30/7C SP.10/C	Attaching parts for 12 WA 1209A, Bracket :— Bolt, 2 BA ... ..						1	—	C.	
		Bolt, 2 BA ... ..						1	—	C.	
		Washer ... ..						2	—	C.	
6511	12 WA 1137A	<b>BRACKET</b> , hinge, inner, centre inner and outboard hinges						3	—	C.	BA.1
6509	12 WA 1143	<b>BRACKET</b> ... ..						1	—	C.	BA.1
4637	15 FC 2053	<b>CIRCLIP</b> , internal (may be made from A.M. Ref. No. 28N/12845 - AGS.2030/9)						1	—	C.	
28N/13511	Hoffmann C.J.1	<b>JOINT</b> , self-aligning ... ..						1	—	C.	
28D/13107 28W/12245	A30/3C SP.10/C	Attaching parts for 12 WA 1137A, Bracket :— Bolt, 2 BA ... ..						2	—	C.	
		Washer ... ..						2	—	C.	

AILERON

Ref. No.	Part No.	Nomenclature						No. Off	M.R.	Cl. of St.	Plate No.
		1	2	3	4	5	6				
9772	12-4WA 29	<b>LEVER</b> , tab, operating ... ..						2	MR	C.	BA.1
		Attaching parts for 12-4WA 29, Lever :—									
28D/8313	AS.1242/9C	Bolt, 2 BA ... ..						1	—	C.	
28D/8316	AS.1242/13C	Bolt, 2 BA ... ..						1	—	C.	
9162	12-4WA 33	Bush, eccentric ... ..						1	—	C.	BA.1
9161	12-4WA 31	Bush, eccentric ... ..						1	—	C.	BA.1
28M/13121	A27/CS	Nut, 2 BA ... ..						2	—	C.	
28P/12462	SP.9/C8	Pin, split ... ..						2	—	C.	
6507	12 WA 1131A	<b>PLATE</b> , nut, special for centre hinge ... ..						2	—	C.	
	12 WA 1129A	<b>PLATE</b> , nut, for hinge rib ... ..						3	—		BA.1
		Attaching parts for 12 WA 1085A/2 and 12 WA 1086A/2, Tabs :—									
7031	12 WA 1111	Bolt, special, at centre, outboard hinges ... ..						1	—	C.	
7030	12 WA 1109	Bolt, special ... ..						3	—	C.	
28M/13121	A27/CS	Nut, 2 BA ... ..						4	—	C.	
28P/12462	SP.9/C8	Pin, split ... ..						4	—	C.	
28W/12252	SP.13/C	Washer ... ..						4	—	C.	
	12 WA 991A	<b>WEIGHT</b> , balance, aileron tip ... ..						2	—		BA.1
		Attaching parts for 12 WA 991A, Weight :—									
28D/8300	AS.1242/1B	Bolt, 4 BA ... ..						12	—	C.	
28M/10287	AGS.2001/B/1	Nut, 4 BA ... ..						2	—	C.	
28W/12305	SP.13/B	Washer ... ..						2	—	C.	
	12 WA 995	<b>WEIGHT</b> , balance, leading edge ... ..						14	—		BA.1
	12 WA 997	<b>WEIGHT</b> , balance, leading edge ... ..						2	—		BA.1
		Attaching parts for 12 WA 995 and 12 WA 997, Weights :—									
28D/12531	A25/3C	Bolt, 2 BA ... ..						2	—	C.	
28L/13124	A27/CT	Locknut, 2 BA ... ..						2	—	C.	
	12 WA 667ND	Shim, spacing, 0.90" dia. 26 SWG, DTD.634 ... ..						QR	—		
28W/12252	SP.13/C	Washer ... ..						2	—	C.	

## AEROFOILS

## WING

Ref. No.	Part No.	Nomenclature						No Off	M.R.	Cl. of St.	Plate No.
		1	2	3	4	5	6				
	12 4W 3A/28	<b>WING, PORT</b> (Mod. Ven. 821) (Pre Mod. Ven. 983)						1	—	A.	BB.1
	12 4W 4A/29	<b>WING, STARBOARD</b> , (Mod. Ven. 821) (Pre Mod. Ven.983) (Less Aileron, Dive brake flap, inboard and outboard flaps, Flap connecting and compression leg—complete with fuel tanks in .020" material, undercarriage retracting mechanism, wheel door and wheel door operating mechanism)						1	—	A.	BB.1
	12 4W 3A/29	<b>WING, PORT</b> (Mod. Ven. 983) (Pre Mod. Ven. 994)						1	—	A.	BB.1
	12 4W 4A/30	<b>WING, STARBOARD</b> (Mod. Ven. 983) (Pre Mod. Ven. 994) (Less Aileron, Dive brake flap, inboard and outboard flaps, Flap connecting plates and compression leg, complete with undercarriage retracting mechanism, wheel door and wheel door operating mechanism.) (Fuel tanks in increased material gauge .030" supplied separately under separate tank order—See Fuel System Section.) Loose items supplied separately for fitting of fuel tanks under separate tank order—See end of Wing, Column 1, Pages BB.2(a), BB.2(b)						1	—	A.	BB.1
	12 4W 3A/30	<b>WING, PORT</b> (Mod. Ven. 994) (Pre Mod. Ven. 575)						1	—	A.	BB.1
	12 4W 4A/31	<b>WING, STARBOARD</b> (Mod. Ven. 994) (Pre Mod. Ven. 575)						1	—	A.	BB.1
	12 4W 4A/32	<b>WING, STARBOARD</b> (Mod. Ven. 994) (Pre Mod. Ven.575) (Mod. Ven. 352) (Less Aileron, Dive brake flap, inboard and outboard flaps, Flap connecting plates and compression leg, complete with undercarriage retracting mechanism, wheel door and wheel door operating mechanism) (Fuel tanks in increased material gauge .030" supplied separately under separate tank order—See Fuel Section) Loose items supplied separately for fitting of fuel tanks under separate tank order—See end of Wing, Column 1, Pages BB.2(a), BB.2(b)						1	—	A.	BB.1
	12 4W 23A/ND	<b>WING, PORT ONLY</b> (Mod. Ven. 235) (S.O.O.) ... (Less Aileron, Dive brake flap, inboard and outboard flaps, Flap connecting plates and compression leg—complete with fuel tanks in .020" material, undercarriage retracting mechanism, wheel door and wheel door operating mechanism)						1	—	A.	BB.1

## AEROFOILS

## WING

Ref. No.	Part No.							Nomenclature	No. Off	M.R.	Cl. of St.	Plate No.
		1	2	3	4	5	6					
	12 4W 17A 12 4W 19A							<b>WING, PORT</b> (Mod. Ven. 575) (Pre Mod. Ven. 983) <b>WING, STARBOARD</b> (Mod. Ven. 575) (Pre Mod. Ven. 983) (Less Aileron, Dive brake flap, inboard and outboard flaps, Flap connecting plates and compression leg, complete with fuel tanks in .020" material, undercarriage retracting mechanism, wheel door and wheel door operating mechanism)	<b>1</b> <b>1</b>	— —	A. A.	BB.1 BB.1
	12 4W 17A/1 12 4W 19A/1							<b>WING, PORT</b> (Mod. Ven. 575) (Mod. Ven. 983) ... <b>WING, STARBOARD</b> (Mod. Ven. 575) (Mod. Ven. 983) (Less Aileron, Dive brake flap, Flap connecting plates, and compression leg, complete with undercarriage retracting mechanism, wheel door and wheel door operating mechanism) (Fuel tanks in increased material gauge .030" supplied separately under separate tank order—See Fuel Section) Loose items supplied separately for fitting of fuel tanks under separate tank order—See end of Wing, Column 1, Pages BB.2(a), BB.2(b)	<b>1</b> <b>1</b>	— —	A. A.	BB.1 BB.1
	12 4W 17A/2							<b>WING, PORT</b> (Mod. Ven. 575) (Mod. Ven. 983) (Mod. Ven. 994)	<b>1</b>	—	A.	BB.1
	12 4W 19A/2							<b>WING, STARBOARD</b> (Mod. Ven. 575) (Mod. Ven. 983) (Mod. Ven. 994)	<b>1</b>	—	A.	BB.1
	12 4W 19A/3							<b>WING, STARBOARD</b> (Mod. Ven. 575) (Mod. Ven. 983) (Mod. Ven. 994) (Mod. Ven. 352) (Less Aileron, Dive brake flap, Flap connecting plates and compression leg, complete with undercarriage retracting mechanism, wheel door and wheel door operating mechanism) (Fuel tanks in increased material gauge .030" supplied separately under separate tank order—See Fuel Section) Loose items supplied separately for fitting of fuel tanks under separate tank order—See end of Wing, Column 1, Pages BB.2(a), BB.2(b)	<b>1</b>	—	A.	BB.1
	12 4W 27A/ND							<b>WING, PORT ONLY</b> (Mod. Ven. 575) (Mod. Ven. 983) (Mod. Ven. 235) (S.O.O.) (Less Aileron, Dive brake flap, inboard and outboard flaps, Flap connecting plates and compression leg, complete with undercarriage retracting mechanism, wheel door and wheel door operating mechanism) (Fuel tanks in increased material gauge .030" supplied separately under separate tank order—See Fuel Section) Loose items supplied separately for fitting of fuel tanks under separate tank order—See end of Wing, Column 1, Pages BB.2(a), BB.2(b)	<b>1</b>	—	A.	BB.1

WING

Ref. No.	Part No.	Nomenclature						No. Off	M.R.	Cl. of St.	Plate No.
		1	2	3	4	5	6				
<b>TANK No. 1</b>											
6A/3822	GP.31010	<b>ADAPTOR</b> , for fuel contents gauge tank unit, pacitor						1	—	C	
646	12 S 25	<b>BLOCK</b> , sealing, on rib No. 1 at vent connection ...						2	—	C	
Attaching parts for 12 S 25, Block :—											
28D/12512	A25/1C	<b>Bolt</b> , 2 BA ... ..						2	—	C	
12165	12 S 1907A	<b>CONNECTION</b> , vent L.H. only ... ..						1	—	C	
12166	12 S 1908A	<b>CONNECTION</b> , vent R.H. only ... ..						1	—	C	
5K/3373	AS.3360/B5B	<b>CONNECTOR</b> , bonding, flexible ... ..						1	—	C	
	DHS.31 Mk 33	<b>CLIP</b> , tubular, fuel pipes ... ..						1	—	C	
2904	CWC.9/Mk 1	<b>CLIP</b> , pipe ... ..						7	—	C	
2905	CWC.9/Mk 2	<b>CLIP</b> , pipe ... ..						2	—	C	
6A/2926	GP.352/062	<b>GAUGE</b> , contents, pacitor tank unit ... ..						1	—	A	
	DHS.160/F/30	<b>HOSE</b> , joint ... ..						1	—	C	
28M/10288	AGS.2001/C/1	<b>NUT</b> , 2 BA for pipe clip bolts ... ..						12	—	C	
28M/10328	AGS.2002/C/1	<b>NUT</b> , 2 BA ... ..						12	—	C	
28M/13086	A27/BP	<b>NUT</b> , 4 BA ... ..						1	—	C	
1577	12 P 619ND	<b>PIPE</b> , feed ... ..						1	—	C	
10192	12 P 895A/ND	<b>PIPE</b> , bonding L.H. ... ..						1	MR	C	
10193	12 P 896A/ND	<b>PIPE</b> , bonding R.H. ... ..						1	MR	C	
609	12 PT 439	<b>RING</b> , jointing gasket ... ..						1	—	C	
28S/2761	A31/B12	<b>SCREW</b> , 4 BA ... ..						1	—	C	
28S/2815	A33/B16	<b>SCREW</b> , 4 BA ... ..						1	—	C	
2891	FTC.6876/5	<b>SLEEVE</b> , moulded (Fireproof) ... ..						2	—	C	
<b>Alternative to</b>											
26FC/10956	MS.382/12	<b>SLEEVE</b> , moulded (Marston) ... ..						2	—	C	
2892	FTC.6876/6	<b>SLEEVE</b> , moulded (Fireproof) ... ..						5	—	C	
<b>Alternative to</b>											
26FC/10512	MS.382/10	<b>SLEEVE</b> , moulded (Marston) ... ..						5	—	C	
9311	12 PT 1435	<b>WASHER</b> , special ... ..						1	MR	C	
28W/8516	AS.470/C	<b>WASHER</b> ... ..						12	—	C	
28W/416642	SP.47/B	<b>WASHER</b> ... ..						1	—	C	
<b>TANK No. 2</b>											
2903	CWC.9/Mk 0	<b>CLIP</b> , pipe ... ..						2	—	C	
2904	CWC.9/Mk 1	<b>CLIP</b> , pipe ... ..						2	—	C	
2906	CWC.9/Mk 3	<b>CLIP</b> , pipe ... ..						2	—	C	
	DHS.31 Mk 31	<b>CLIP</b> , tubular, fuel pipes ... ..						1	—	C	
	DHS.31 Mk 50	<b>CLIP</b> , tubular, fuel pipes ... ..						1	—	C	
5K/3413	AS.3360/B7B	<b>CONNECTOR</b> , bonding, flexible ... ..						1	—	C	
5K/3372	AS.3360/C5B	<b>CONNECTOR</b> , bonding, flexible ... ..						1	—	C	
28M/13086	A27/BP	<b>NUT</b> , 4 BA ... ..						2	—	C	
28M/10328	AGS.2002/C/1	<b>NUT</b> , 2 BA ... ..						24	—	C	
623	12 P 7A	<b>PIPE</b> , feed ... ..						1	—	C	
1487	12 S 893A/ND	<b>PIPE</b> , bonding assembly ... ..						1	—	C	
654	12 S 137A/ND	<b>PIPE</b> , vent ... ..						1	—	C	
11174	12 PT 1845A	<b>PLATE</b> , sealing ... ..						2	—	C	
28S/2761	A31/B12	<b>SCREW</b> , 4 BA ... ..						2	—	C	
2890	FTC.6876/3	<b>SLEEVE</b> , moulded (Fireproof) ... ..						2	—	C	
<b>Alternative to</b>											
	MS.382/20	<b>SLEEVE</b> , moulded (Marston) ... ..						2	—	C	
2894	FTC.6876/8	<b>SLEEVE</b> , moulded (Fireproof) ... ..						2	—	C	
<b>Alternative to</b>											
10210	MS.382/7	<b>SLEEVE</b> , moulded (Marston) ... ..						2	—	C	
28W/416642	SP.47/B	<b>WASHER</b> ... ..						2	—	C	

WING

Ref. No.	Part No.	Nomenclature						No. Off	M.R.	Cl. of St.	Plate No.
		1	2	3	4	5	6				
<b>TANK No. 3</b>											
28D/12531	A25/3C	BOLT, 2 BA	...	...	...	...	...	12	—	C.	
2904	CWC.9/Mk.1	CLIP, pipe	...	...	...	...	...	1	—	C.	
2907	CWC.9/Mk.4	CLIP, pipe	...	...	...	...	...	1	—	C.	
	DHS.31/Mk.32	CLIP, tubular	...	...	...	...	...	1	—	C.	
5K/3373	AS.3360/B5B	CONNECTOR, bonding, flexible	...	...	...	...	...	1	—	C.	
6A/2934	SIMMOND	CONNECTOR, cable	...	...	...	...	...	1	—	B.	
	Type 712/093										
6A/2927	GP.352/063	GAUGE, contents, pacitor	...	...	...	...	...	1	—	A.	
28M/13086	A27/BP	NUT, 4 BA	...	...	...	...	...	1	—	C.	
28M/10328	AGS.2002/C/1	NUT, 2 BA	...	...	...	...	...	16	—	C.	
10187	12 P 889A/ND	PIPE, feed L.H. only	...	...	...	...	...	1	MR	C.	
10188	12 P 890A/ND	PIPE, feed R.H. only	...	...	...	...	...	1	MR	C.	
647	12 S 27A	PIPE, vent L.H. only	...	...	...	...	...	1	—	C.	
648	12 S 28A	PIPE, vent R.H. only	...	...	...	...	...	1	—	C.	
609	12 PT 439	RING, gasket	...	...	...	...	...	1	—	C.	
28S/2761	A31/B12	SCREW	...	...	...	...	...	1	—	C.	
2893	FTC.6876/7	SLEEVE, moulded (Fireproof)	...	...	...	...	...	1	—	C.	
		Alternative to									
7923	MS.382/8	SLEEVE, moulded (Marston)	...	...	...	...	...	1	—	C.	
2889	FTC.6876/1	SLEEVE, moulded (Fireproof)	...	...	...	...	...	1	—	C.	
		Alternative to									
10550	MS.382/28	SLEEVE, moulded (Marston)	...	...	...	...	...	1	—	C.	
28W/8516	AS.470/C	WASHER	...	...	...	...	...	12	—	C.	
28W/416642	SP.47/B	WASHER	...	...	...	...	...	1	—	C.	
<b>TANK No. 4</b>											
2904	CWC.9/Mk.1	CLIP, pipe	...	...	...	...	...	4	—	C.	
2907	CWC.9/Mk.4	CLIP, pipe	...	...	...	...	...	1	—	C.	
	DHS.31/Mk.33	CLIP, tubular	...	...	...	...	...	1	—	C.	
5K/3373	AS.3360/B5B	CONNECTOR, bonding, flexible	...	...	...	...	...	1	—	C.	
5998	12 S 1525A	ELBOW, vent, L.H. only...	...	...	...	...	...	1	—	C.	
5999	12 S 1526A	ELBOW, vent, R.H. only	...	...	...	...	...	1	—	C.	
	DHS.160F/30	HOSE, joint	...	...	...	...	...	1	—	C.	
28M/13086	A27/BP	NUT, 4 BA	...	...	...	...	...	1	—	C.	
28M/10328	AGS.2002/C1	NUT, 2 BA	...	...	...	...	...	24	—	C.	
11174	12 PT 1845A	PLATE, sealing	...	...	...	...	...	1	—	C.	
28S/2761	A31/B12	SCREW	...	...	...	...	...	1	—	C.	
2889	FTC.6876/1	SLEEVE, moulded (Fireproof)	...	...	...	...	...	1	—	C.	
		Alternative to									
10550	MS.382/28	SLEEVE, moulded (Marston)	...	...	...	...	...	1	—	C.	
2892	FTC.6876/6	SLEEVE, moulded (Fireproof)	...	...	...	...	...	1	—	C.	
		Alternative to									
26FC/10512	MS.382/10	SLEEVE, moulded (Marston)	...	...	...	...	...	1	—	C.	
2893	FTC.6876/7	SLEEVE, moulded (Fireproof)	...	...	...	...	...	1	—	C.	
		Alternative to									
7923	MS.382/8	SLEEVE, moulded (Marston)	...	...	...	...	...	1	—	C.	
28W/416642	SP.47/B	WASHER	...	...	...	...	...	1	—	C.	

AEROFOILS

WING

Ref. No.	Part No.	Nomenclature						No. Off	M.R.	Cl. of St.	Plate No.
		1	2	3	4	5	6				
5W/439	Rotax A.0903	<b>ACTUATOR</b> , aileron tab operating (see wiring in port wing)						1	—	A.	
28F/10431	AGS.1147/B	<b>ADAPTOR</b> , hydraulic pressure pipe through false spar						1	—	C.	
28F/10849	AGS.1147/C	<b>ADAPTOR</b> , hydraulic return pipe, through false spar						1	—	C.	
821	12 M 161	<b>ADJUSTER</b> , cable for tank jettison inboard of rib No. 2						1	—	C.	
	12 W 2715ND	<b>ANGLE</b> , attachment, for fuel tank No. 1, screen, along main spar, Port						1	MR		
	12 W 2716ND	<b>ANGLE</b> , attachment, for fuel tank No. 1 screen, along main spar, Starboard						1	MR		
	12 W 4749ND	<b>ANGLE</b> , attachment, tank screen along front spar, to inboard channels, Port						1	MR		
	12 W 4750ND	<b>ANGLE</b> , attachment, tank screen along front spar, to inboard channels, Starboard						1	MR		
7812	12 W 519	<b>ANGLE</b> , joint, for bottom and top stub boom shells, Port						1	MR	C.	BB.1
7813	12 W 520	<b>ANGLE</b> , joint, for bottom and top stub boom shells, Starboard						1	MR	C.	BB.1
	12 W 2527	<b>ANGLE</b> , support, for fuel tank door landing plate along main spar, Port						1	MR		
	12 W 2528	<b>ANGLE</b> , support, for fuel tank door landing plate along main spar, Starboard						1	MR		
	12 W 757A	<b>ARCH</b> , nose rib No. 3, in bottom skin, for fuel tank No. 2, Port						1	MR		
	12 W 758A	<b>ARCH</b> , nose rib No. 3, in bottom skin, for fuel tank No. 2, Starboard						1	MR		
	12 W 759A	<b>ARCH</b> , nose rib No. 4, in bottom skin, for fuel tank No. 2, Port						1	MR		BB.3
	12 W 760A	<b>ARCH</b> , nose rib No. 4, in bottom skin, for fuel tank No. 2, Starboard						1	MR		BB.3
	12 W 761A	<b>ARCH</b> , nose rib No. 8, in bottom skin, for fuel tank No. 4, Port						1	MR		BB.2
	12 W 762A	<b>ARCH</b> , nose rib No. 8, in bottom skin, for fuel tank No. 4, Starboard						1	MR		BB.3
	12 W 763A	<b>ARCH</b> , nose rib No. 9, in bottom skin, for fuel tank No. 4, Port						1	MR		BB.3
	12 W 764A	<b>ARCH</b> , nose rib No. 9, in bottom skin, for fuel tank No. 4, Starboard						1	MR		BB.3
	12 W 765A	<b>ARCH</b> , nose rib No. 10, in bottom skin, for fuel tank No. 4, Port						1	MR		BB.3
	12 W 766A	<b>ARCH</b> , nose rib No. 10, in bottom skin, for fuel tank No. 4, Starboard						1	MR		BB.3
	12 W 459A	<b>ARCH</b> , nose rib No. 3, in top skin, for fuel tank No. 2, Port						1	MR		BB.3
	12 W 460A	<b>ARCH</b> , nose rib No. 3, in top skin, for fuel tank No. 2, Starboard						1	MR		BB.3
	12 W 451A	<b>ARCH</b> , nose rib No. 4, in top skin, for fuel tank No. 2, Port						1	MR		BB.3

AEROFOILS

WING

Ref. No.	Part No.	Nomenclature						No. Off	M.R.	Cl. of St.	Plate No.
		1	2	3	4	5	6				
	12 W 452A	ARCH,	nose	rib	No. 4, in top skin, for fuel tank No. 2, Starboard			1	MR		BB.3
	12 W 513A	ARCH,	nose	rib	No. 8, in top skin, for fuel tank No. 4, Port			1	MR		BB.3
	12 W 514A	ARCH,	nose	rib	No. 8, in top skin, for fuel tank No. 4, Starboard			1	MR		BB.3
	12 W 467A	ARCH,	nose	rib	No. 9, in top skin, for fuel tank No. 4, Port			1	MR		BB.3
	12 W 468A	ARCH,	nose	rib	No. 9, in top skin, for fuel tank No. 4, Starboard			1	MR		BB.3
	12 W 497A	ARCH,	nose	rib	No. 10, in top skin, for fuel tank No. 4, Port			1	MR		BB.3
	12 W 498A	ARCH,	nose	rib	No. 10, in top skin, for fuel tank No. 4, Starboard			1	MR		BB.3
	12 W 3629A/ND	ARCH,	rib	No. 1B, for fuel tank No. 1, Port	...			1	MR		BB.1
	12 W 3630A/ND	ARCH,	rib	No. 1B, for fuel tank No. 1, Starboard	...			1	MR		BB.1
	12 W 1245A	ARCH,	rib	No. 6, for fuel tank No. 3, Port	...			1	MR		BB.3
	12 W 1246A	ARCH,	rib	No. 6, for fuel tank No. 3, Starboard	...			1	MR		BB.3
	12 W 2143A	ARCH,	wheel	well, Port	...			1	MR		BB.3
	12 W 2144A	ARCH,	wheel	well, Starboard	...			1	MR		BB.3
127	12 CF 65	AXLE,	aileron	control pulley	...			1	MR	C.	BB.15
		Attaching parts for 12 CF 65, Axle :—									
28M/13122	A27/GS	Nut,	$\frac{1}{8}$ "	BSF	...			1	MR	C.	
28P/12462	SP.9/C.8	Pin,	split	...	...			1	MR	C.	
28W/12254	SP.13/G	Washer	...	...	...			1	MR	C.	
28F/10797	AGS.1129/A	BANJO,	at	dive brake flap jack, lower end	...			1	—	C.	
2812	12 W 2603	BLISTER,	wheel	well, on top skin, Port	...			1	MR	C.	BB.2
	12 W 2604	BLISTER,	wheel	well, on top skin, Starboard	...			1	MR		BB.2
7877	12 W 3785	BLOCK,	clamp	bottom half, at rib No. 5, for drop tank fuel and air pressure conduits, Port				1	MR	C.	BB.2
7878	12 W 3786	BLOCK,	clamp	bottom half, at rib No. 5, for drop tank fuel and air pressure conduits, Starboard	—			1	MR	C.	BB.2
		Attaching parts for 12 W 3785 and 12 W 3786, Blocks :—									
28D/12532	A.25/4C	Bolt,	2	BA	...			2	MR	C.	
28D/8343	AS.1248/4C	Bolt,	2	BA	...			1	MR	C.	
28M/12929	A27/CP	Nut,	2	BA	...			3	MR	C.	
28W/12252	SP.13/C	Washer	...	...	...			3	MR	C.	
	12 W 5471	BLOCK,	clamp	for use with $\frac{7}{8}$ " o/d conduit, alternative to 12 W 3783, Clamp block used with $1\frac{1}{8}$ " o/d conduit, Port				1	—		BB.2
	12 W 5472	BLOCK,	clamp	for use with $\frac{7}{8}$ " o/d conduit, alternative to 12 W 3784 clamp block, used with $1\frac{1}{8}$ " o/d conduit, Starboard				1	—		BB.2
		Attaching parts for 12 W 5471 and 12 W 5472, Block :—									
28D/12532	A25/4C	Bolt,	2	BA	...			2	—	C.	
28D/8343	AS.1248/4C	Bolt,	2	BA	...			1	—	C.	
28M/12929	A27/CP	Nut,	2	BA	...			3	—	C.	
28W/12252	SP.13/C	Washer	...	...	...			3	—	C.	
	12 M 303	BLOCK,	clamp	half, at rib No. 1A, for bomb control cable conduit, bottom, Port				1	MR		BB.16

WING

Ref. No.	Part No.	Nomenclature						No Off	M.R.	Cl. of St.	Plate No.
		1	2	3	4	5	6				
	12 M 304	<b>BLOCK</b> , clamp, half, at rib No. 1A, for bomb control cable conduit, bottom, Starboard						1	MR		BB.16
	12 M 301	<b>BLOCK</b> , clamp, half, at rib No. 1A, for bomb control cable conduit, top, Port						1	MR		BB.16
	12 M 302	<b>BLOCK</b> , clamp, half, at rib No. 1A, for bomb control cable conduit, top, Starboard						1	MR		BB.16
		Attaching parts for 12 M 303, 12 M 304, 12 M 301 and 12 M 302, Blocks (per pair) :—									
28D/12516	A25/11C	Bolt, 2 BA ... ..						2	MR	C.	
28M/10288	AGS.2001/C/1	Nut, 2 BA ... ..						2	MR	C.	
28W/12252	SP.13/C	Washer, 2 BA ... ..						2	MR	C.	
7721	12 M 157	<b>BLOCK</b> , clamp, half, at rib No. 1B, for bomb control cable conduit, Port top and Starboard bottom						2	MR	C.	BB.16
7722	12 M 158	<b>BLOCK</b> , clamp, half, at rib No. 1B, for bomb control cable conduit Port bottom and Starboard top						2	MR	C.	BB.16
		Attaching parts for 12 M 157 and 12 M 158, Blocks :—									
28D/12513	A25/2C	Bolt, 2 BA ... ..						2	MR	C.	
28M/10288	AGS.2001/C/1	Nut, 2 BA ... ..						2	MR	C.	
7875	12 W 3783	<b>BLOCK</b> , clamp, top half, at rib No. 5, for drop tank fuel and air pressure conduits, Port						1	MR	C.	BB.2
7876	12 W 3784	<b>BLOCK</b> , clamp, top half, at rib No. 5, for drop tank fuel and air pressure conduits, Starboard						1	MR	C.	BB.2
		Attaching parts for 12 W 3783 and 12 W 3784, Blocks :—									
28D/12532	A25/4C	Bolt, 2 BA ... ..						1	MR	C.	
28D/8343	AS.1248/4C	Bolt, 2 BA ... ..						2	MR	C.	
28M/12929	A27/CP	Nut, 2 BA ... ..						3	MR	C.	
28W/12252	SP.13/C	Washer, 2 BA ... ..						3	MR	C.	
6693	12 W 1055	<b>BLOCK</b> , in wing tip trailing edge, inner ... ..						1	MR		BB.5
	12 W 1057	<b>BLOCK</b> , in wing tip trailing edge, outer ... ..						1	MR	C.	BB.5
	12 N 65	<b>BLOCK</b> , saddle, at conduit between ribs No. 5 and 7, Port						1	MR		BB.19
	12 N 66	<b>BLOCK</b> , saddle, at conduit between ribs No. 5 and 7, Starboard						1	MR		BB.19
28D/12558	12 W 5269	<b>BLOCK</b> , stop, for aileron, at inboard end of shroud						2	MR		BB.2
	AS.1242/12G	<b>BOLT</b> , <sup>5</sup> / <sub>16</sub> BSF, at main spar R.P. outer anchor nut plate						2	—	C.	
	12 W 4023	<b>BOLT</b> , at main spar R.P. inner anchor nut plate ...						2	—	C.	BB.9
28F/8221	AGS.1135/A	<b>BOLT</b> , banjo, at dive brake flap jack, lower end ...						1	—	C.	
	12 W 3257	<b>BOLT</b> , rib No. 2 to main spar attachment ... ..						4	MR		BB.3
	12 W 3257	<b>BOLT</b> , rib No. 5 to main spar attachment, inboard and outboard lower						3	MR		BB.3
	12 W 3259	<b>BOLT</b> , rib No. 5 to main spar attachment, outboard upper						1	MR		BB.3
3880	12 W 1063A	<b>BOX</b> , contact, for drop tank electrical release ...						1	MR	B.	BB.8
	12 W 1067	<b>BASE</b> ... ..						1	MR		BB.8
28D/12559	AS.1247/5B	<b>BOLT</b> , 4 BA, for securing cover ... ..						2	—	C.	
	12 W 1069	<b>CONTACT</b> ... ..						1	MR		BB.8
361	12 W 1071	<b>COVER</b> , Perspex ... ..						1	—	C.	BB.8
28M/10288	AGS.2001/C/1	<b>NUT</b> , 2 BA, securing cable ... ..						1	—	C.	
28M/12929	A27/CP	<b>NUT</b> , 2 BA, securing contact ... ..						1	MR	C.	

WING

Ref. No.	Part No.	Nomenclature						No. Off	M.R.	Cl. of St.	Plate No.
		1	2	3	4	5	6				
28W/12252	SP.13/C	<b>WASHER</b> ... ..						1	—	C.	
		Attaching parts for 12 W 1063A, Box :—									
28D/8300	AS.1242/1B	Bolt, 4 BA ... ..						4	MR	C.	
28M/10287	AGS.2001/B/1	Nut, 4 BA ... ..						4	MR	C.	
	12 W 1229	<b>BRACKET</b> , aileron centre hinge ... ..						1	MR		BB.14
		Attaching parts for 12 W 1229, Bracket :—									
28D/12812	A25/12E	Bolt, 1/4" BSF ... ..						4	MR	C.	
3866	12 W 2165	Shim ... ..						1	—	C.	BB.14
28W/12496	SP.15/E	Washer ... ..						6	MR	C.	
28W/12352	SP.10/E	Washer ... ..						2	MR	C.	
10137	12 CF 809A/1	<b>BRACKET</b> , aileron inboard hinge, Port ... ..						1	—	C.	BB.14
10138	12 CF 810A/1	<b>BRACKET</b> , aileron inboard hinge, Starboard ... ..						1	—	C.	BB.14
4707	DHS.183/J40	<b>BUSH</b> , knurled ... ..						1	—	C.	
		Attaching parts for 12 CF 809A/1 and 12 CF 810A/1, Brackets :—									
28D/12543	A25/6E	Bolt, 1/4" BSF ... ..						5	—	C.	
28D/8327	AS.1242/6E	Bolt, 1/4" BSF ... ..						3	—	C.	
3859	12 W 1225	<b>BRACKET</b> , aileron outer hinge ... ..						1	MR	C.	BB.14
		Attaching parts for 12 W 1225, Bracket :—									
28D/12570	A25/11E	Bolt, 1/4" BSF ... ..						4	MR	C.	
3860	12 W 2249	Shim ... ..						1	—	C.	BB.14
28W/12496	SP.15/E	Washer ... ..						6	MR	C.	
28W/12352	SP.10/E	Washer ... ..						2	MR	C.	
	N.002619A	<b>BRACKET</b> , and spring clips, at G4F compass detector unit cable connector in Starboard wing						1	MR		BB.16
7821	12 W 1869A	<b>BRACKET</b> , angle, at inboard stiffening channel on spar for R.P., Port inner and Starboard outer						1	MR	C.	BB.9
7822	12 W 1870A	<b>BRACKET</b> , angle, at inboard stiffening channel on spar for R.P., Port outer and Starboard inner						1	MR	C.	BB.9
7833	12 W 1873A	<b>BRACKET</b> , angle, at outboard stiffening channel on spar for R.P., Port inner						1	MR	C.	BB.9
7824	12 W 1874A	<b>BRACKET</b> , angle, at outboard stiffening channel on spar for R.P., Starboard inner						1	MR	C.	BB.9
7825	12 W 1877A	<b>BRACKET</b> , angle, at outboard stiffening channel on spar for R.P., Port outer						1	MR	C.	BB.9
7826	12 W 1878A	<b>BRACKET</b> , angle, at outboard stiffening channel on spar for R.P., Starboard outer						1	MR	C.	BB.9
7841	12 W 2657A	<b>BRACKET</b> , angle, for inboard fairleads between rib Nos. 1 and 2 on main spar, inboard, Port						1	MR	C.	BB.9
7842	12 W 2658A	<b>BRACKET</b> , angle, for inboard fairleads between ribs Nos. 1 and 2 on main spar, inboard, Starboard						1	MR	C.	BB.9
7843	12 W 2659A	<b>BRACKET</b> , angle, for inboard fairleads between rib Nos. 1 and 2 on main spar, outboard, Port						1	MR	C.	BB.9
7844	12 W 2660A	<b>BRACKET</b> , angle, for inboard fairleads between rib Nos. 1 and 2 on main spar, outboard, Starboard						1	MR	C.	BB.9

WING

Ref. No.	Part No.	Nomenclature						No Off	M.R.	Cl. of St.	Plate No.
		1	2	3	4	5	6				
7852	12 W 2869A	<b>BRACKET</b> , angle, for outboard fairlead between rib Nos. 1 and 2 on main spar, inboard, Port						1	MR	C.	BB.9
7853	12 W 2870A	<b>BRACKET</b> , angle, for outboard fairlead between rib Nos. 1 and 2 on main spar, inboard, Starboard						1	MR	C.	BB.9
7845	12 W 2661A	<b>BRACKET</b> , angle, for outboard fairlead between rib No. 1 and 2 on main spar, outboard, Port						1	MR	C.	BB.9
7846	12 W 2662A	<b>BRACKET</b> , angle, for outboard fairlead between rib Nos. 1 and 2 on main spar, outboard, Starboard						1	MR	C.	BB.9
7855	12 W 2971	<b>BRACKET</b> , attachment, at main spar, for centre channel between spar and rib No. 1, Port						1	MR	C.	BB.9
7856	12 W 2972	<b>BRACKET</b> , attachment, at main spar, for centre channel between spar and rib No. 1, Starboard						1	MR	C.	BB.9
28D/12512	A25/1C	Attaching parts for 12 W 2971 and 12 W 2972, Brackets : Bolt, 2 BA ... ..						2	MR	C.	
7857	12 W 2973	<b>BRACKET</b> , attachment, at main spar, for upper channel between spar and rib No. 1, Port						1	MR	C.	BB.9
7858	12 W 2974	<b>BRACKET</b> , attachment, at main spar, for upper channel between spar and rib No. 1, Starboard						1	MR	C.	BB.9
	12 W 2983	<b>BRACKET</b> , attachment, at rib No. 1, for centre and lower channels between main spar and rib No. 1, Port						2	MR		BB.9
	12 W 2984	<b>BRACKET</b> , attachment, at rib No. 1, for centre and lower channels between main spar and rib No. 1, Starboard						2	MR		BB.9
	12 W 2985	<b>BRACKET</b> , attachment, at rib No. 1, for upper channel between main spar and rib No. 1, Port						1	MR		BB.9
	12 W 2986	<b>BRACKET</b> , attachment, at rib No. 1, for upper channel between main spar and rib No. 1, Starboard						1	MR		BB.9
	12 W 4911A	<b>BRACKET</b> , attachment of rib 7 to false spar, Port						1	MR		BB.1
	12 W 4912A	<b>BRACKET</b> , attachment of rib 7 to false spar, Starboard						1	MR		BB.1
	12 W 2103	<b>BRACKET</b> , attachment, undercarriage diaphragm drag members to rib No. 2						2	MR		BB.16
		Attaching parts for 12 W 2103, Bracket :—									
28D/12570	A25/11E	Bolt, $\frac{1}{4}$ " BSF ... ..						1	MR	C.	
7308	DHS.201/7G	Bolt, $\frac{5}{16}$ " BSF ... ..						1	MR	C.	
28M/12928	A27/EP	Nut, $\frac{1}{4}$ " BSF ... ..						1	MR	C.	
7311	DHS.202/G	Nut, $\frac{5}{16}$ " BSF, thin ... ..						1	MR	C.	
28W/12253	SP.13/E	Washer ... ..						1	MR	C.	
28W/12254	SP.13/G	Washer ... ..						1	MR	C.	
	12 W 3805	<b>BRACKET</b> , bomb/drop tank release, at nose rib No. 6, centre, Port						1	MR		BB.8
	12 W 3805	<b>BRACKET</b> , bomb/drop tank release, at nose rib No. 6, front and rear, Starboard						2	MR		BB.8
	12 W 3806	<b>BRACKET</b> , bomb/drop tank release, at nose rib No. 6, centre, Starboard						1	MR		BB.8

WING

Ref. No.	Part No.	Nomenclature						No. Off	M.R.	Cl. of St.	Plate No.
		1	2	3	4	5	6				
	12 W 3806	<b>BRACKET</b> , bomb/drop tank release, at nose rib No. 6, front and rear, Port						2	MR		
28D/12513	A25/2C	Attaching parts for 12 W 3805 and 12 W 3806, Brackets :									
28M/10288	AGS.2001/C/1	Bolt, 2 BA	...	...	...	...	2	MR	C.		
28W/12296	SP.15/C	Nut, 2 BA	...	...	...	...	2	MR	C.		
		Washer	...	...	...	...	2	MR	C.		
7871	12 W 3625	<b>BRACKET</b> , corner, at undercarriage rear diaphragm, Port						1	MR	C.	BB.6
7872	12 W 3626	<b>BRACKET</b> , corner, at undercarriage rear diaphragm, Starboard						1	MR	C.	BB.6
		Attaching parts for 12 W 3625 and 12 W 3626, Brackets :									
28D/12519	A25/3E	Bolt, 1/4" BSF	...	...	...	...	3	MR	C.		
28M/12928	A27/EP	Nut, 1/4" BSF	...	...	...	...	3	MR	C.		
28W/12253	SP.13/E	Washer	...	...	...	...	3	MR	C.		
7136	12 W 1271	<b>BRACKET</b> , front, at undercarriage diaphragm, rib No. 2, Port						1	MR	C.	BB.6
7820	12 W 1272	<b>BRACKET</b> , front, at undercarriage diaphragm, rib No. 2, Starboard						1	MR	C.	BB.6
		Attaching parts for 12 W 1271 and 12 W 1272, Brackets :—									
28D/8507	AS.1242/5C	Bolt, 2 BA	...	...	...	...	2	MR	C.		
28M/10288	AGS.2001/C/1	Nut, 2 BA	...	...	...	...	2	MR	C.		
28W/12252	SP.13/C	Washer	...	...	...	...	2	MR	C.		
	12 W 4381A	<b>BRACKET</b> , fuel connection, wing tip tank, L.H. ...						1	MR		BB.8
	12 W 4382A	<b>BRACKET</b> , fuel connection, wing tip tank, R.H. ...						1	MR		BB.8
374	12 W 3679	<b>BRACKET</b> , guard, for flexible pipes at undercarriage front diaphragm, port						1	MR	C.	BB.6
375	12 W 3680	<b>BRACKET</b> , guard, for flexible pipes at undercarriage front diaphragm, Starboard						1	MR	C.	BB.6
8817	12 W 5623	<b>BRACKET</b> , hinge, inboard flap, inner and outboard flap, outer (Mod. Ven. 486)						2	MR	C.	BB.10
		Attaching parts for 12 W 5623, Bracket :—									
28D/15328	AS.3297/4E	Bolt, 1/4" BSF, for inner bracket	...	...	...	...	2	—	C.		
28D/12520	A25/4E	Bolt, 1/4" BSF, for outboard bracket	...	...	...	...	2	—	C.		
28M/12928	A27/EP	Nut, 1/4" BSF	...	...	...	...	4	—	C.		
	12 W 5619ND	Shim, for inboard bracket	...	...	...	...	1	—		BB.10	
8820	12 W 5621ND	Shim, for outboard bracket	...	...	...	...	1	—	C.	BB.10	
28W/12253	SP.13/E	Washer	...	...	...	...	4	—	C.		
8818	12 W 5625	<b>BRACKET</b> , hinge, inboard flap, outer (Mod. Ven. 486)						1	—	C.	BB.10
		Attaching parts for 12 W 5625, Bracket :—									
28D/8325	AS.1242/4E	Bolt, 1/4" BSF	...	...	...	...	2	—	C.		
28D/8326	AS.1242/5E	Bolt, 1/4" BSF	...	...	...	...	1	—	C.		
28D/12144	AS.1246/4E	Bolt, 1/4" BSF	...	...	...	...	1	—	C.		
28L/12931	A27/ET	Locknut, 1/4" BSF	...	...	...	...	4	—	C.		
8819	12 W 5627	Shim	...	...	...	...	1	—	C.	BB.10	
28W/12253	SP.13/E	Washer	...	...	...	...	4	—	C.		

WING

Ref. No.	Part No.	Nomenclature						No. Off	M.R.	Cl. of St.	Plate No.
		1	2	3	4	5	6				
295	12 W 189	<b>BRACKET</b> , hinge, outboard flap, inner, Port ...						1	MR	C.	BB.10
296	12 W 190	<b>BRACKET</b> , hinge, outboard flap, inner, Starboard						1	MR	C.	BB.10
		Attaching parts for 12 W 189 and 12 W 190, Brackets :—									
28D/12544	A25/8E	Bolt, $\frac{1}{4}$ " BSF ...						2	MR	C.	
28D/12817	A25/8G	Bolt, $\frac{5}{16}$ " BSF, bottom ...						2	MR	C.	
28M/12928	A27/EP	Nut, $\frac{3}{8}$ " BSF, top ...						2	MR	C.	
28M/13375	A27/GP	Nut, $\frac{5}{16}$ " BSF, bottom ...						2	MR	C.	
28W/12297	SP.16/E	Washer, top ...						2	MR	C.	
28W/12347	SP.16/G	Washer, bottom ...						2	MR	C.	
373	12 W 3627	<b>BRACKET</b> , main compression leg pick-up ...						2	MR	C.	BB.6
		Attaching parts for 12 W 3627, Bracket :—									
372	12 W 3493	Bolt, upper ...						8	MR	C.	BB.6
371	12 W 1727	Bolt, lower ...						4	MR	C.	BB.6
28M/13123	A27/JS	Nut, $\frac{3}{8}$ " BSF ...						23	MR	C.	
28W/12256	SP.13/L	Washer ...						23	MR	C.	
	12 W 4317A	<b>BRACKET</b> , mounting, for flap indicator transmitter in starboard wing						1	MR		BB.10
	12 W 3239	<b>BRACKET</b> , mounting, for flexible pipe fairlead, on false spar at jack flap						1	MR		BB.16
		Attaching parts for 12 W 3239, Bracket :—									
28D/12518	A25/2E	Bolt, $\frac{3}{8}$ " BSF ...						12	MR	C.	
28M/12928	A27/EP	Nut, $\frac{1}{2}$ " BSF ...						12	MR	C.	
28W/12297	SP.16/E	Washer ...						10	—	C.	
4837	12 N 1285A	<b>BRACKET</b> , mounting, for terminal block, at rib No. 1, forward of false spar, in starboard wing						1	—	C.	BB.16
		Attaching parts for 12 N 1285A, Bracket :—									
28D/8308	AS.1242/3C	Bolt, 2 BA ...						3	—	C.	
	12 U 355	<b>BRACKET</b> , mounting, for undercarriage up-limit micro switch						1	MR		BB.16
	12 W 4915	<b>BRACKET</b> , mounting, Servodyne, L.H. ...						1	—		BB.14
	12 W 4916	<b>BRACKET</b> , mounting, Servodyne, R.H. ...						1	—		BB.14
7840	12 W 2653A	<b>BRACKET</b> , nut, at fairlead channels, rib No. 2 ...						5	MR	C.	BB.12
7854	12 W 2961A	<b>BRACKET</b> , nut, at No. 4 fairlead channel, rib No. 2						1	MR	C.	BB.12
9316	12 W 4815A	<b>BRACKET</b> , nut, at fairlead channel rib No. 2 (Mod. Ven. 162)						4	MR	C.	BB.12
3893	12 W 2299A	<b>BRACKET</b> , pulley, in wing tip for drop tank jettison cable, forward, Port						1	MR	C.	BB.8
3894	12 W 2300A	<b>BRACKET</b> , pulley, in wing tip for drop tank jettison cable, forward, Starboard						1	MR	C.	BB.8
308	12 W 3515A/ND	<b>BRACKET</b> , pulley and cover plate, Port ...						1	MR	C.	BB.8
309	12 W 3516A/ND	<b>BRACKET</b> , pulley and cover plate, Starboard ...						1	MR	C.	BB.8
28D/12633	A.25/7E	<b>BOLT</b> , $\frac{1}{4}$ " BSF, pulley attachment ...						1	—	C.	
28M/10290	AGS.2001/E/1	<b>NUT</b> , $\frac{1}{4}$ " BSF, pulley attachment ...						1	—	C.	
28R/13491	AS.107	<b>PULLEY</b> , single, shrouded ...						1	—	C.	BB.8
		Attaching parts for 12 W 2299A and 12 W 2300A, Brackets :—									
28D/12512	A25/1C	Bolt, 2 BA ...						6	MR	C.	
28W/12252	SP.13/C	Washer ...						6	MR	C.	

WING

Ref. No.	Part No.	Nomenclature						No. Off	M.R.	Cl. of St.	Plate No.
		1	2	3	4	5	6				
3895	12 W 3097A	<b>BRACKET</b> , pulley, in wing tip for drop tank jettison cable, rear, Port						1	MR	C.	BB.8
3896	12 W 3098A	<b>BRACKET</b> , pulley, in wing tip for drop tank jettison cable, rear, Starboard						1	MR	C.	BB.8
310	12 W 3517A/ND	<b>BRACKET</b> , pulley and cover plate, Port ...						1	MR	C.	BB.8
311	12 W 3518A/ND	<b>BRACKET</b> , pulley and cover plate, Starboard ...						1	MR	C.	BB.8
28D/12633	A25/7E	<b>BOLT</b> , $\frac{1}{4}$ " BSF, pulley attachment ...						1	—	C.	
28M/10290	AGS.2001/E/1	<b>NUT</b> , $\frac{1}{4}$ " BSF, pulley attachment ...						1	—	C.	
28R/13491	AS.107	<b>PULLEY</b> , single, shrouded ...						1	—	C.	
Attaching parts for 12 W 3097A and 12 W 3098A, Brackets :—											
28D/12513	A25/2C	Bolt, 2 BA ...						12	MR	C.	
28W/12252	SP.13/C	Washer ...						12	MR	C.	
362	12 W 109A	<b>BRACKET</b> , radius rod pick-up ...						2	MR	C.	BB.6
Attaching parts for 12 W 109A, Bracket :—											
28D/12128	AS.1242/4G	Bolt, $\frac{5}{16}$ " BSF, centre ...						3	MR	C.	
28D/10743	AS.1242/6G	Bolt, $\frac{5}{16}$ " BSF, lower, front bracket ...						3	MR	C.	
28D/10743	AS.1242/6G	Bolt, $\frac{5}{16}$ " BSF, upper and lower, rear bracket ...						6	MR	C.	
28D/9755	AS.1242/7G	Bolt, $\frac{5}{16}$ " BSF, upper, front bracket ...						3	MR	C.	
28M/13122	A27/GS	Nut, $\frac{5}{16}$ " BSF ...						18	MR	C.	
28W/12254	SP.13/G	Washer ...						18	MR	C.	
2197	12 W 1325	<b>BRACKET</b> , rear, at undercarriage diaphragm, rib No. 2, Port						1	MR	C.	BB.6
2198	12 W 1326	<b>BRACKET</b> , rear, at undercarriage diaphragm, rib No. 2, Starboard						1	MR	C.	BB.6
Attaching parts for 12 W 1325 and 12 W 1326, Brackets :											
28D/8507	AS.1242/5C	Bolt, 2 BA ...						2	MR	C.	
28M/10288	AGS.2001/C/1	Nut, 2 BA ...						2	MR	C.	
28W/12252	SP.13/C	Washer ...						2	MR	C.	
	12 W 5021A	<b>BRACKET</b> , reinforcing, aileron hinge L.H. ...						1	—		BB.5
	12 W 5022A	<b>BRACKET</b> , reinforcing, aileron hinge R.H. ...						1	—		BB.5
Attaching parts for 12 W 5021A and 12 W 5022A, Brackets :—											
28D/8308	AS.1242/3C	Bolt, 2 BA ...						8	—	C.	
7135	12 W 421	<b>BRACKET</b> , reinforcing, at inner hinge of outboard flap, forward of false spar, inboard lower and outboard upper						2	MR	C.	BB.16
7293	12 W 423	<b>BRACKET</b> , reinforcing, at inner hinge of outboard flap, forward of false spar, outboard lower and inboard upper						2	MR	C.	BB.16
	12 W 2667	<b>BRACKET</b> , reinforcing, at rib No. 3, rear of main spar, Port						1	MR		BB.3
	12 W 2668	<b>BRACKET</b> , reinforcing, at rib No. 3, rear of main spar, Starboard						1	MR		BB.3
Attaching parts for 12 W 2667 and 12 W 2668, Brackets to spar :—											
28D/8313	AS.1242/9C	Bolt, 2 BA ...						3	MR	C.	
28M/12929	A27/CP	Nut, 2 BA ...						3	MR	C.	
28W/12296	SP.15/C	Washer ...						3	MR	C.	

WING

Ref. No.	Part No.	Nomenclature						No. Off	M.R.	Cl. of St.	Plate No.
		1	2	3	4	5	6				
	12 W 3597	<b>BRACKET</b> , reinforcing, for slinging attachment, at rib No. 2, Port						1	MR		BB.2
	12 W 3598	<b>BRACKET</b> , reinforcing, for slinging attachment, at rib No. 2, Starboard						1	MR		BB.2
		Attaching parts for 12 W 3597 and 12 W 3598, Brackets :—									
28D/12531	A25/3C	Bolt, 2 BA, at top skin and rib web ... ..						18	MR	C.	
28D/12633	A25/7E	Bolt, $\frac{1}{4}$ " BSF, at rib upper extrusion ... ..						3	MR	C.	
28D/12787	A25/5G	Bolt, $\frac{5}{16}$ " BSF, at rib lower extrusion ... ..						2	MR	C.	
28M/12929	A27/CP	Nut, 2 BA ... ..						18	MR	C.	
28M/12928	A27/EP	Nut, $\frac{1}{4}$ " BSF ... ..						3	MR	C.	
28M/13375	A27/GP	Nut, $\frac{5}{16}$ " BSF ... ..						2	MR	C.	
28W/12355	SP.16/C	Washer ... ..						18	MR	C.	
28W/12496	SP.15/E	Washer ... ..						3	MR	C.	
28W/12324	SP.15/G	Washer ... ..						2	MR	C.	
	12 W 169	<b>BRACKET</b> , rib attachment, at front top wing/fuselage joint, Port						1	MR		BB.15
	12 W 170	<b>BRACKET</b> , rib attachment, at front top wing/fuselage joint, Starboard						1	MR		BB.15
		Attaching parts for 12 W 169 and 12 W 170, Brackets :—									
28D/8308	AS.1242/3C	Bolt, 2 BA ... ..						1	MR	C.	
28D/12533	A25/5C	Bolt, 2 BA ... ..						2	MR	C.	
28D/12520	A25/4E	Bolt, $\frac{1}{4}$ " BSF ... ..						5	MR	C.	
28D/12542	A25/5E	Bolt, $\frac{1}{4}$ " BSF ... ..						1	MR	C.	
28M/12929	A27/CP	Nut, 2 BA ... ..						3	MR	C.	
28M/12928	A27/EP	Nut, $\frac{1}{4}$ " BSF ... ..						6	MR	C.	
28W/12252	SP.13/C	Washer ... ..						3	MR	C.	
28W/12253	SP.13/E	Washer ... ..						6	MR	C.	
	12 CF 845A	<b>BRACKET</b> , support, aileron sprocket, on rear face of false spar, L.H.						1	—		BB.13
27S/132	Ransome & Marles CK. $\frac{1}{4}$ A	<b>BEARING</b> , ball-race ... ..						1	—	B.	
27S/	Ransome & Marles CK. $\frac{1}{4}$ B	<b>BEARING</b> , ball-race ... ..						1	—	B.	
4708	DHS.183/J35	<b>BUSH</b> , Knurled ... ..						1	—	C.	
		Attaching parts for 12 CF 845A, Bracket :—									
28D/13476	A30/4C	Bolt, 2 BA ... ..						2	—	C.	
28D/8309	AS.1242/4C	Bolt, 2 BA ... ..						2	—	C.	
28M/13121	A27/CS	Nut, 2 BA ... ..						4	—	C.	
28P/12462	SP.9/C8	Pin, split ... ..						4	—	C.	
28W/12252	SP.13/C	Washer ... ..						4	—	C.	
	12 CF 881A	<b>BRACKET</b> , support, aileron sprocket, on rear face of false spar, R.H.						1	—		BB.13
4707	DHS.183/J40	<b>BUSH</b> , knurled ... ..						1	—	C.	
		Attaching parts for 12 CF 881A, Bracket :—									
28D/13746	A30/4C	Bolt, 2 BA ... ..						2	—	C.	
28D/8309	AS.1242/4C	Bolt, 2 BA ... ..						2	—	C.	
28M/13121	A27/CS	Nut, 2 BA ... ..						4	—	C.	
28P/12462	SP.9/C8	Pin, split ... ..						4	—	C.	
28W/12252	SP.13/C	Washer ... ..						4	—	C.	

WING

Ref. No.	Part No.	Nomenclature						No. Off	M.R.	Cl. of St.	Plate No.
		1	2	3	4	5	6				
	12 CF 851	<b>BRACKET</b> , support, for tab actuator ... ..						1	—		BB.13
		Attaching parts for 12 CF 851, Bracket :—									
28D/14316	A30/6C	Bolt, 2 BA ... ..						1	—	C.	
28D/13108	A30/8C	Bolt, 2 BA ... ..						2	—	C.	
28M/13121	A27/CS	Nut, 2 BA ... ..						3	—	C.	
28P/12462	SP.9/C8	Pin, split ... ..						3	—	C.	
28W/12252	SP.13/C	Washer ... ..						3	—	C.	
	12 W 3161A	<b>BRACKET</b> , tank, screen at rib No. 2, front, Port						1	MR		
	12 W 3162A	<b>BRACKET</b> , tank screen, at rib No. 2, front, Starboard						1	MR		
4717	12 CF 973A	<b>CABLE</b> , aileron control, lower, from joint on rib No. 1, to connection on false spar						1	—	C.	BB.13
4716	12 CF 971A	<b>CABLE</b> , aileron control, upper, from joint on rib No. 1, to connection on false spar						1	—	C.	BB.13
		Attaching parts for 12 CF 971A, Cable :—									
28P/815	SP4Y/A5	Pin, shackle ... ..						1	—	C.	
28P/12587	SP.9/C4	Pin, split ... ..						1	—	C.	
1305	12 M 59A/1	<b>CABLE</b> , bomb control, outboard of rib No. 2						1	—	C.	BB.8
		Attaching parts for 12 M 59A/1, Cable :—									
28M/10288	AGS.2001/C/1	Nut, 2 BA ... ..						2	—	C.	
28P/812	SP4Y/A2	Pin, shackle ... ..						1	—	C.	
28P/12587	SP.9/C4	Pin, split ... ..						1	—	C.	
1306	12 W 4313	Washer, cup ... ..						2	—	C.	BB.8
1919	12-20M 23A	<b>CABLE</b> , drop tank jettison ... ..						1	—	C.	BB.8
		Attaching parts for 12-20M 23A, Cable :—									
28M/10287	AGS.2001/B/1	Nut, 4 BA ... ..						1	—	C.	
1921	12-2M 191	Washer, cup ... ..						1	—	C.	BB.8
27K/192	DS.23/2	<b>CABLE</b> , for bomb and drop tank jettison control Teleflex No. 2, inboard of rib No. 2						QR	—	C.	
	B.34947 (8'-6" long)	<b>CABLE</b> , for drop tank jettison, inboard of rib No. 2, Port, Teleflex						1	—		
	B.34947 (8'-0" long)	<b>CABLE</b> , for drop tank jettison, inboard of rib No. 2, Starboard, Teleflex						1	—		
329	12 W 2389A	<b>CAP</b> , access, at bomb pylon ... ..						1	—	C.	BB.8
4709	12 CF 831A	<b>CHAIN</b> , lever and sprocket operating, at false spar, Port						1	—	C.	BB.13
4710	12 CF 832A	<b>CHAIN</b> , lever and sprocket operating, at false spar, Starboard						1	—	C.	BB.13
27KB/157	AS.168/2	<b>BOLT</b> , complete with nut ... ..						1	—	C.	
4711	12 CF 817	<b>LINK</b> ... ..						1	—	C.	BB.13
	12 W 2975	<b>CHANNEL</b> , base, between main spar and rib No. 1, Port						1	MR		BB.9
	12 W 2976	<b>CHANNEL</b> , base, between main spar and rib No. 1, Starboard						1	MR		BB.9
	12 W 3435	<b>CHANNEL</b> , centre, between main spar and rib No. 1, Port						1	MR		BB.9
	12 W 3436	<b>CHANNEL</b> , centre, between main spar and rib No. 1, Starboard						1	MR		BB.9

WING

Ref. No.	Part No.	Nomenclature						No Off	M.R.	Cl. of St.	Plate No.
		1	2	3	4	5	6				
	12 W 2617ND	<b>CHANNEL</b> , forward, at fairlead No. 1, rib No. 2, Port						1	MR		BB.12
	12 W 2618ND	<b>CHANNEL</b> , forward, at fairlead No. 1, rib No. 2, Starboard						1	MR		BB.12
	12 W 2619ND	<b>CHANNEL</b> , rear, fairlead No. 1, rib No. 2, Port						1	MR		BB.12
	12 W 2620ND	<b>CHANNEL</b> , rear, at fairlead No. 1, rib No. 2, Starboard						1	MR		BB.12
		Attaching parts for 12 W 2617ND, 12 W 2618ND, 12 W 2619ND and 12 W 2620ND, Channels (Per pair) :—									
28D/12531	A25/3C	Bolt, 2 BA, centre ... ..						4	MR	C.	
28D/12543	A25/6E	Bolt, 1/2" BSF, lower... ..						2	MR	C.	
28D/12633	A25/7E	Bolt, 1/2" BSF, upper ... ..						2	MR	C.	
28M/12929	A27/CP	Nut, 2 BA, centre ... ..						4	MR	C.	
28M/12928	A27/EP	Nut, 1/2" BSF, upper and lower ... ..						4	MR	C.	
28W/12252	SP.13/C	Washer, centre ... ..						4	MR	C.	
28W/12253	SP.13/E	Washer, upper and lower ... ..						4	MR	C.	
	12 W 2621ND	<b>CHANNEL</b> , forward, at fairlead No. 2, rib No. 2, Port						1	MR		BB.12
	12 W 2622ND	<b>CHANNEL</b> , forward, at fairlead No. 2, rib No. 2, Starboard						1	MR		BB.12
	12 W 2623ND	<b>CHANNEL</b> , rear, at fairlead No. 2, rib No. 2, Port						1	MR		BB.12
	12 W 2624ND	<b>CHANNEL</b> , rear, at fairlead No. 2, rib No. 2, Starboard						1	MR		BB.12
		Attaching parts for 12 W 2621ND, 12 W 2622ND, 12 W 2623ND and 12 W 2624ND, Channels (per pair) :—									
28D/12520	A25/4E	Bolt, 1/4" BSF, centre ... ..						3	MR	C.	
28D/12633	A25/7E	Bolt, 1/2" BSF, lower... ..						3	MR	C.	
28D/12816	A25/7G	Bolt, 5/16" BSF, upper ... ..						3	MR	C.	
28M/12928	A27/EP	Nut, 1/4" NSF, centre and lower ... ..						6	MR	C.	
28M/13375	A27/GP	Nut, 5/16" BSF, upper ... ..						3	MR	C.	
28W/12253	SP.13/E	Washer, centre and lower ... ..						6	MR	C.	
28W/12254	SP.13/G	Washer, upper ... ..						3	MR	C.	
	12 W 2625ND	<b>CHANNEL</b> , forward, at fairlead No. 3, rib No. 2, Port						1	MR		BB.12
	12 W 2626ND	<b>CHANNEL</b> , forward, at fairlead No. 3, rib No. 2, Starboard						1	MR		BB.12
	12 W 2627ND	<b>CHANNEL</b> , rear, at fairlead No. 3, rib No. 2, Port						1	MR		BB.12
	12 W 2628ND	<b>CHANNEL</b> , rear, at fairlead No. 3, rib No. 2, Starboard						1	MR		BB.12
		Attaching parts for 12 W 2625ND, 12 W 2626ND, 12 W 2627ND and 12 W 2628ND, Channels (per pair) :—									
28D/12542	A25/5E	Bolt, 1/2" BSF, upper ... ..						3	MR	C.	
28D/12633	A25/7E	Bolt, 1/2" BSF, lower... ..						3	MR	C.	
28M/12928	A27/EP	Nut, 1/2" BSF, upper and lower ... ..						6	MR	C.	
28W/12253	SP.13/E	Washer, upper and lower ... ..						6	MR	C.	
	12 W 2629ND	<b>CHANNEL</b> , forward, at fairlead No. 4, rib No. 2, Port						1	MR		BB.12
	12 W 2630ND	<b>CHANNEL</b> , forward, at fairlead, No. 4, rib No. 2, Starboard						1	MR		BB.12
	12 W 2631ND	<b>CHANNEL</b> , rear, at fairlead No. 4, rib No. 2, Port						1	MR		BB.12

AEROFOILS

WING

Ref. No.	Part No.	Nomenclature						No. Off	M.R.	Cl. of St.	Plate No.
		1	2	3	4	5	6				
	12 W 2632ND	<b>CHANNEL</b> , rear, at fairlead No. 4, rib No. 2, Starboard Attaching parts for 12 W 2629ND, 12 W 2630ND, 12 W 2631ND and 12 W 2632ND, Channels (per pair) :—						1	MR		BB.12
28D/12531	A25/3C	Bolt, 2 BA, centre ... ..						2	MR	C.	
28D/12543	A25/6E	Bolt, $\frac{1}{4}$ " BSF, lower... ..						2	MR	C.	
28D/12633	A25/7E	Bolt, $\frac{1}{4}$ " BSF, upper ... ..						2	MR	C.	
28M/12929	A27/CP	Nut, 2 BA, centre ... ..						2	MR	C.	
28M/12928	A27/EP	Nut, $\frac{1}{4}$ " BSF, upper and lower ... ..						4	MR	C.	
28W/12252	SP.13/C	Washer, centre ... ..						2	MR	C.	
28W/12253	SP.13/E	Washer, upper and lower ... ..						4	MR	C.	
	12 W 2633ND	<b>CHANNEL</b> , forward, at fairlead No. 5, rib No. 2, Port						1	MR		BB.12
	12 W 2634ND	<b>CHANNEL</b> , forward, at fairlead No. 5, rib No. 2, Starboard						1	MR		BB.12
	12 W 2635ND	<b>CHANNEL</b> , rear, at fairlead No. 5, rib No. 2, Port						1	MR		BB.12
	12 W 2636ND	<b>CHANNEL</b> , rear, at fairlead No. 5, rib No. 2, Starboard Attaching parts for 12 W 2363ND, 12 W 2634ND, 12 W 2635ND and 12 W 2636ND, Channels (per pair) :—						1	MR		BB.12
28D/12531	A25/3C	Bolt, 2 BA, centre ... ..						2	MR	C.	
28D/12543	A25/6E	Bolt, $\frac{1}{4}$ " BSF, upper ... ..						2	MR	C.	
28D/12639	A25/6G	Bolt, $\frac{5}{16}$ " BSF, lower ... ..						1	MR	C.	
28M/12929	A27/CP	Nut, 2 BA, centre ... ..						2	MR	C.	
28M/12928	A27/EP	Nut, $\frac{1}{4}$ " BSF, upper... ..						2	MR	C.	
28M/13375	A27/GP	Nut, $\frac{5}{16}$ " BSF, lower ... ..						1	MR	C.	
28W/12252	SP.13/C	Washer, centre ... ..						2	MR	C.	
28W/12253	SP.13/E	Washer, upper ... ..						2	MR	C.	
28W/12254	SP.13/G	Washer, lower ... ..						1	MR	C.	
	12 W 2663A	<b>CHANNEL</b> , inboard, at main spar between ribs No. 1 and 2 Attaching parts for 12 W 2663A, Channel :—						1	MR		BB.9
28D/12629	A25/8C	Bolt, 2 BA ... ..						3	MR	C.	
28M/10288	AGS.2001/C/1	Nut, 2 BA ... ..						3	MR	C.	
	12 W 3261ND	Tube, distance, $\frac{5}{8}$ " o/d $\times$ 17 SWG $\times$ 0.6" long, DTD.440						3	MR		
28W/12296	SP.15/C	Washer ... ..						3	MR	C.	
	12 W 3433	<b>CHANNEL</b> , lower, between main spar and rib No. 1, Port						1	MR		BB.9
	12 W 3434	<b>CHANNEL</b> , lower, between main spar and rib No. 1, Starboard						1	MR		BB.9
	12 W 2665A	<b>CHANNEL</b> , outboard, at main spar between ribs No. 1 and 2 Attaching parts for 12 W 2665A, Channel :—						1	MR		BB.9
28D/12629	A25/8C	Bolt, 2 BA ... ..						2	MR	C.	
28M/10288	AGS.2001/C/1	Nut, 2 BA ... ..						2	MR	C.	
	12 W 3261ND	Tube, distance, $\frac{5}{8}$ " o/d $\times$ 17 SWG $\times$ 0.6" long, DTD.440						2	MR		
28W/12296	SP.15/C	Washer ... ..						2	MR	C.	
	12 W 1321	<b>CHANNEL</b> , stringer attachment, forward of main spar at rib No. 1, Port						3	MR		BB.7
	12 W 1322	<b>CHANNEL</b> , stringer attachment, forward of main spar at rib No. 1, Starboard						3	MR		BB.7

WING

Ref. No.	Part No.	Nomenclature						No Off	M.R.	Cl. of St.	Plate No.
		1	2	3	4	5	6				
	12 W 1361	<b>CHANNEL</b> , stringer attachment, forward of main spar at rib No. 1, centre Port and front Starboard						2	MR		BB.7
	12 W 1362	<b>CHANNEL</b> , stringer attachment, forward of main spar at rib No. 1, front Port and centre Starboard						2	MR		BB.7
	12 W 1359	<b>CHANNEL</b> , stringer attachment, forward of main spar at rib No. 1, rear, Port						2	MR		BB.7
	12 W 1360	<b>CHANNEL</b> , stringer attachment, forward of main spar at rib No. 1, rear, Starboard						2	MR		BB.7
	12 W 2955ND	<b>CHANNEL</b> , upper, at fairlead No. 3, rib No. 2 ...						1	MR		BB.12
28D/12817	A25/BG	Attaching parts for 12 W 2955ND, Channel :—									
28M/13375	A27/GP	Bolt, $\frac{5}{16}$ " BSF ... ..						3	MR	C.	
28W/12254	SP.13/G	Nut, $\frac{5}{16}$ " BSF ... ..						3	MR	C.	
		Washer ... ..						3	MR	C.	
	12 W 3635	<b>CHANNEL</b> , upper between main spar and rib No. 1, Port						1	MR		BB.9
	12 W 3636	<b>CHANNEL</b> , upper, between main spar and rib No. 1, Starboard						1	MR		BB.9
6583	12 S 1409	<b>CLAMP</b> , sealing at rib No. 1, Port ... ..						2	—	C.	BB.15
		Attaching parts for 12 S 1409, Clamp :—									
28D/11227	AS.1247/2B	Bolt, 4 BA ... ..						4	—	C.	
28M/10318	AGS.2002/B/3	Nut, 4 BA ... ..						4	—	C.	
28W/12306	SP.15/B	Washer ... ..						8	—	C.	
	12 S 1629	<b>CLAMP</b> , sealing, at rib No. 1, Starboard ... ..						2	—		BB.15
		Attaching parts for 12 S 1629, Clamp :—									
28D/11227	AS.1247/2B	Bolt, 4 BA ... ..						4	—	C.	
28M/10318	AGS.2002/B/3	Nut, 4 BA ... ..						4	—	C.	
28W/12306	SP.15/B	Washer ... ..						8	—	C.	
792	12 A 97A	<b>CLIP</b> , for cannon heating pipe, at main spar in Starboard wing						1	MR	C.	BB.15
		Attaching parts for 12 A 97A, Clip :—									
28D/12512	A25/1C	Bolt, 2 BA ... ..						2	MR	C.	
28M/10288	AGS.2001/C/1	Nut, 2 BA ... ..						2	MR	C.	
349	12 W 3591A	<b>CLIP</b> , link actuating, for flap indicator transmitter in Starboard wing						1	—	C.	BB.10
		Attaching parts for 12 W 3591A, Clip :—									
28D/12629	A25/8C	Bolt, 2 BA ... ..						1	—	C.	
28M/10288	AGS.2001/C/1	Nut, 2 BA ... ..						1	—	C.	
28W/12252	SP.13/C	Washer ... ..						1	—	C.	
28E/14066	AS.3181/4B	<b>CLIP</b> , for hydraulic pressure pipe, at aileron inboard hinge						1	—	C.	
28E/14068	AS.3181/6B	<b>CLIP</b> , for hydraulic return pipe, at aileron inboard hinge						1	—	C.	
		Attaching parts for AS.3181/4B and AS.3181/6B, Clips :—									
28M/10327	AGS.2002/B/1	Nut, 4 BA ... ..						1	—	C.	
28S/2863	A32/B16	Screw, 4 BA ... ..						1	—	C.	
28E/8184	AGS.605/2	<b>CLIP</b> , pipe joint, at cannon heating duct and pipe coupling hoses in Starboard wing						2	—	C.	
	12 N 63ND	<b>CLIP</b> , saddle, for electrical cable conduit, at rib No. 5						1	MR		BB.19

WING

Ref. No.	Part No.	Nomenclature						No. Off	M.R.	Cl. of St.	Plate No.
		1	2	3	4	5	6				
	12 N 59ND	CLIP, saddle, for electrical cable conduit, at rib No. 6						1	MR		BB.19
	12 N 1371	CLIP, saddle, for electrical cable conduit, at rib No. 7						1	—		BB.19
	AS.1160/9	CLIP, saddle, for electrical cable conduits, in Port wing						6	MR		
	AS.1160/9	CLIP, saddle, for electrical cable conduits, in starboard wing						5	MR		
207	12 W 3387A	CLIP, support, for pipe on dive brake flap jack ...						1	—	C.	BB.11
		Attaching parts for 12 W 3387A, Clip :—									
28D/12629	A25/8C	Bolt, 2 BA ... ..						1	—	C.	
28M/13121	A27/CS	Nut, 2 BA, slotted ... ..						1	—	C.	
28P/12462	SP.9/C8	Pin, split ... ..						1	—	C.	
	DHS.30 Mk. 39	CLIP, tubular, for securing drop tank fuel and air pressure conduits						8	MR		
		Attaching parts for DHS.30 Mk. 39, Clip :—									
28D/10570	AS.1247/1C	Bolt, 2 BA, at ribs No. 8, 9 and 11 ... ..						1	MR	C.	
28M/10288	AGS.2001/C/1	Nut, 2 BA, at rib No. 7 ... ..						1	MR	C.	
28M/10281	AGS.2001/C/3	Nut, 2 BA, at ribs No. 8, 9 and 11 ... ..						1	MR	C.	
28S/2862	A32/C16	Screw, 2 BA, at rib No. 7 ... ..						1	MR	C.	
28E/14084	AS.3181/14C	CLIP, tubular for re-securing drop tank fuel and air pressure conduits Alternative to DHS.30/Mk. 39 Clip						10	—	C.	
27K/550	DS.56/3	CONDUIT, bomb and drop tank jettison cables, Teleflex No. 2, inboard of rib No. 2						QR	MR	C.	
	12 N 55A/ND	CONDUIT, elbow, for electrical cable, at rib No. 11 in Starboard wing						1	MR		BB.19
	12 W 2295ND	CONDUIT, electrical cable, between ribs No. 2 and 5 in leading edge, $\frac{9}{16}$ " o/d x 22 SWG, T.9						1	MR		BB.19
	12 N 47ND	CONDUIT, electrical cable, between ribs No. 5 and 7, $1\frac{1}{8}$ " o/d x 22 SWG x 2'-5-1" long, T.9 (Pre Mod. Ven. 77)						1	MR		BB.19
	12 N 989ND	CONDUIT, electrical cable, between ribs No. 5 and 7, $1\frac{1}{8}$ " o/d x 22 SWG x 2'-5-1" long, T.9 (Mod. Ven. 77)						1	MR		BB.19
	12 N 49ND	CONDUIT, electrical cable, between ribs No. 8 and 13, in Port wing, $1\frac{1}{8}$ " o/d x 22 SWG x 6'-2" long, T.9						1	MR		BB.19
	12 N 45ND	CONDUIT, electrical cable, between ribs No. 8 and 10, in Starboard wing, $1\frac{1}{8}$ " o/d x 22 SWG x 2'-10-2" long, T.9						1	MR		BB.19
	12 N 43ND	CONDUIT, electrical cable, between ribs No. 12 and 13, in Starboard wing, $1\frac{1}{8}$ " o/d x 22 SWG x 17-3" long, T.9						1	MR		BB.19
	12 W 4879A	CONDUIT, electrical cable, on tank screen, rib No. 1, Port						1	—		BB.19
	12 W 4880A	CONDUIT, electrical cable, on tank screen, rib No. 1, Starboard						1	—		BB.19
	12 W 5063A/ND	CONDUIT, for drop tank air pressure hose, centre, Port, $1\frac{1}{8}$ " o/d x 22 SWG, L.56						1	MR		BB.19
	12 W 5064A/ND	CONDUIT, for drop tank air pressure hose, centre, Starboard, $1\frac{1}{8}$ " o/d x 22 SWG, L.56						1	MR		BB.19
	12 W 5457A/ND	CONDUIT, for drop tank air pressure hose, centre, Port, $\frac{7}{8}$ " o/d x 22 SWG, L.56 alternative to 12 W 5063A/ND						1	MR		BB.19

WING

Ref. No.	Part No.	Nomenclature						No. Off	M.R.	Cl. of St.	Plate No.
		1	2	3	4	5	6				
	12 W 5458A/ND	<b>CONDUIT</b> , for drop tank air pressure hose, centre, Starboard, $\frac{7}{8}$ " o/d $\times$ 22 SWG, L.56, alternative to 12 W 5064A/ND						1	MR		BB.19
	12 W 5131ND	<b>CONDUIT</b> , for drop tank air pressure hose, inboard, Port, $1\frac{1}{8}$ " o/d $\times$ 22 SWG, L.56						1	MR		BB.19
	12 W 5132ND	<b>CONDUIT</b> , for drop tank air pressure hose, inboard, Starboard, $1\frac{1}{8}$ " o/d $\times$ 22 SWG, L.56						1	MR		BB.19
	12 W 5453ND	<b>CONDUIT</b> , for drop tank air pressure hose, inboard, Port, $\frac{7}{8}$ " o/d $\times$ 22 SWG, L.56, alternative to 12 W 5131ND						1	MR		BB.19
	12 W 5454ND	<b>CONDUIT</b> , for drop tank air pressure hose, inboard, Starboard, $\frac{7}{8}$ " o/d $\times$ 22 SWG, L.56, alternative to 12 W 5132ND						1	MR		BB.19
	12 W 3795A/ND	<b>CONDUIT</b> , for drop tank air pressure hose, outboard, Port, $1\frac{1}{8}$ " o/d $\times$ 22 SWG, L.56						1	MR		BB.19
	12 W 3796A/ND	<b>CONDUIT</b> , for drop tank air pressure hose, outboard, Starboard, $1\frac{1}{8}$ " o/d $\times$ 22 SWG, L.56						1	MR		BB.19
	12 W 5461A/ND	<b>CONDUIT</b> , for drop tank air pressure hose, outboard, Port, $\frac{7}{8}$ " o/d $\times$ 22 SWG, L.56, alternative to 12 W 3795ND						1	MR		BB.19
	12 W 5462A/ND	<b>CONDUIT</b> , for drop tank air pressure hose, outboard, Starboard, $\frac{7}{8}$ " o/d $\times$ 22 SWG, L.56, alternative to 12 W 3795ND						1	MR		BB.19
	12 W 5297ND	<b>CONDUIT</b> , for drop tank fuel and air pressure hose, centre outboard, $1\frac{1}{8}$ " o/d $\times$ 22 SWG, L.56						2	—		BB.19
	12 W 5463ND	<b>CONDUIT</b> , for drop tank fuel and air pressure hose, centre outboard, $\frac{7}{8}$ " o/d $\times$ 22 SWG, L.56, alternative to 12 W 5297ND						2	—		BB.19
	12 W 5065A/ND	<b>CONDUIT</b> , for drop tank fuel hose, centre, Port						1	MR		BB.19
	12 W 5066A/ND	<b>CONDUIT</b> , for drop tank fuel hose, centre, Starboard						1	MR		BB.19
	12 W 5097ND	<b>CONDUIT</b> , for drop tank fuel hose, inboard, Port, $1\frac{1}{8}$ " o/d $\times$ 22 SWG, L.56						1	MR		BB.19
	12 W 5098ND	<b>CONDUIT</b> , for drop tank fuel hose, inboard, Starboard, $1\frac{1}{8}$ " o/d $\times$ 22 SWG, L.56						1	MR		BB.19
	12 W 3659A/ND	<b>CONDUIT</b> , for drop tank fuel hose, outboard, Port						1	MR		BB.19
	12 W 3660A/ND	<b>CONDUIT</b> , for drop tank fuel hose, outboard, Starboard						1	MR		BB.19
	12 W 1783ND	<b>CONDUIT</b> , jettison cable, forward, between ribs No. 2 and 13 in leading edge, $\frac{5}{16}$ " o/d $\times$ 22 SWG, T.9 (Make from Ref. No. 30B/627						1	MR		BB.19
	12 W 1773ND	<b>CONDUIT</b> , jettison cable, rear, between rib No. 2 to half-way between ribs No. 5 and 6 in leading edge, $\frac{5}{16}$ " o/d $\times$ 22 SWG, T.9 (Make from Ref. No. 30B/627)						1	MR		BB.19
27K/—	B.10699	<b>CONNECTOR</b> , at bomb jettison cable adjuster inboard of rib No. 2, Teleflex						1	—		
	12 W 3873ND	<b>CORD</b> , elastic, for turbo-starter cartridge stowage, Port wing ( $\frac{1}{4}$ " dia. $\times$ 30-0" long, F.16)						1	—		
	R.98356	<b>COUPLING</b> , hose, between cannon heating duct and pipe in Starboard wing, 2-0" i/d $\times$ 3-0" long, Neoprene (Make from Ref. No. 32C/459)						1	—		BB.15
28F/11166	AGS.1147/A	<b>COUPLING</b> , pipe, at clip on dive drake flap jack						1	—	C.	
	12 W 527A	<b>DIAPHRAGM</b> , front, at bomb drop tank pylon, Port						1	MR		BB.1
	12 W 528A	<b>DIAPHRAGM</b> , front, at bomb drop tank pylon, Starboard						1	MR		BB.1

WING

Ref. No.	Part No.	Nomenclature						No. Off	M.R.	Cl. of St.	Plate No.
		1	2	3	4	5	6				
	12 W 523A	<b>DIAPHRAGM</b> , rear, at bomb drop tank pylon, Port						1	MR		BB.1
	12 W 524A	<b>DIAPHRAGM</b> , rear, at bomb drop tank pylon, Starboard						1	MR		BB.1
26FC/317	DHS.199	<b>TERMINAL</b> , bonding ... ..						1	MR	C.	
6694	12 W 1311A	<b>DIAPHRAGM</b> , stub boom, bottom, Port ... ..						1	MR	C.	BB.7
6695	12 W 1312A	<b>DIAPHRAGM</b> , stub boom, bottom, Starboard ... ..						1	MR	C.	BB.7
28D/8341	AS.1248/1C	<b>BOLT</b> , 2 BA, securing cover plate ... ..						6	MR	C.	
	12 W 4931A/ND	<b>PLATE</b> , cover, Port ... ..						1	MR		BB.7
	12 W 3929A/ND	<b>PLATE</b> , cover, Starboard ... ..						1	MR		BB.7
	12 W 1307A	<b>DIAPHRAGM</b> , stub boom, top, Port ... ..						1	MR		BB.7
	12 W 1308A	<b>DIAPHRAGM</b> , stub boom, top, Starboard ... ..						1	MR		BB.7
28D/8342	AS.1248/2C	<b>BOLT</b> , 2 BA, securing cover plate ... ..						12	MR	C.	
	12 W 4193ND	<b>PLATE</b> , cover, 5-75" dia. x 16 SWG, DTD.610 (Make from Ref. No. 30B/1449)						1	MR		BB.7
	12 W 2081	<b>DIAPHRAGM</b> , stub boom shell, bottom half, Port						1	MR		BB.7
	12 W 2082	<b>DIAPHRAGM</b> , stub boom shell, bottom half, Starboard						1	MR		BB.7
	12 W 2079	<b>DIAPHRAGM</b> , stub boom shell, top half, Port ...						1	MR		BB.7
	12 W 2080	<b>DIAPHRAGM</b> , stub boom shell, top half, Starboard						1	MR		BB.7
	12 W 5089A	<b>DIAPHRAGM</b> , tank bay, at rib No. 1 and false spar, Port (Mod. Ven. 302)						1	MR		BB.2
	12 W 5090A	<b>DIAPHRAGM</b> , tank bay, at rib No. 1 and false spar, Starboard (Mod. Ven. 302)						1	MR		BB.2
	12 W 399A	<b>DIAPHRAGM</b> , tank, in leading edge, inboard, Port						1	MR		BB.2
	12 W 400A	<b>DIAPHRAGM</b> , tank, in leading edge, inboard, Starboard						1	MR		BB.2
	12 W 401	<b>DIAPHRAGM</b> , tank, in leading edge, outboard, Port						1	MR		BB.2
	12 W 402	<b>DIAPHRAGM</b> , tank, in leading edge, outboard, Starboard						1	MR		BB.2
6212	12 W 3579A	<b>DIAPHRAGM</b> , undercarriage, front, Port ... ..						1	MR	C.	BB.3
6213	12 W 3580A	<b>DIAPHRAGM</b> , undercarriage, front, Starboard ... ..						1	MR	C.	BB.3
		Attaching parts for 12 W 3579A and 12 W 3580A, Diaphragms :-									
7302	DHS.201/3E	Bolt, 1/4" BSF, inner, centre ... ..						3	MR	C.	
7305	DHS.201/6E	Bolt, 1/4" BSF, inner, lower ... ..						3	MR	C.	
7309	DHS.201/8G	Bolt, 1/8" BSF, inner, upper ... ..						3	MR	C.	
7310	DHS.202/E	Nut, 1/4" BSF, thin, for inner centre and lower bolts						6	MR	C.	
7311	DHS.202/G	Nut, 1/8" BSF, thin, for inner upper bolts ... ..						3	MR	C.	
28W/12496	SP.15/E	Washer, for inner centre and lower bolts ... ..						6	MR	C.	
28W/12324	SP.15/G	Washer, for inner upper bolts ... ..						3	MR	C.	
	12 W 3577A	<b>DIAPHRAGM</b> , undercarriage, rear, Port ... ..						1	MR		BB.3
6211	12 W 3578A	<b>DIAPHRAGM</b> , undercarriage, rear, Starboard ... ..						1	MR	C.	BB.3
		Attaching parts for 12 W 3577A and 12 W 3578A, Diaphragms :-									
7303	DHS.201/4E	Bolt, 1/8" BSF, inner, centre ... ..						3	MR	C.	
7305	DHS.201/6E	Bolt, 1/8" BSF, inner, lower ... ..						3	MR	C.	
7309	DHS.201/8G	Bolt, 1/16" BSF, inner, upper ... ..						3	MR	C.	
7306	DHS.201/4G	Bolt, 1/16" BSF, outer, upper centre ... ..						2	MR	C.	
7307	DHS.201/5G	Bolt, 1/16" BSF, outer, lower centre ... ..						2	MR	C.	
7308	DHS.201/7G	Bolt, 1/16" BSF, outer, upper and lower ... ..						4	MR	C.	
7311	DHS.202/G	Nut, 1/8" BSF, thin ... ..						11	MR	C.	
7310	DHS.202/E	Nut, 1/8" BSF, thin, for inner centre and lower bolts						6	MR	C.	
28W/12496	SP.15/E	Washer, for inner centre and lower bolts ... ..						6	MR	C.	
28W/12324	SP.15/G	Washer, for inner upper and outer bolts ... ..						11	MR	C.	

WING

Ref. No.	Part No.	Nomenclature						No. Off	M.R.	Cl. of St.	Plate No.
		1	2	3	4	5	6				
1137	12 W 4279	<b>DIFFUSER</b> , on leading edge at rib No. 8, Port ...						1	—	C.	BB.1
1138	12 W 4280	<b>DIFFUSER</b> , on leading edge at rib No. 8, Starboard						1	—	C.	BB.1
28D/8307	AS.1242/2C	Attaching parts for 12 W 4279 and 12 W 4280, Diffusers : Bolt, 2 BA ... .. .						13	—	C.	
885	12 Z 4491ND 12 W 4137A	<b>DOOR</b> , access between ribs 11 and 12, Starboard ...						1	—		
		<b>DOOR</b> , access at bottom skin at heat exchanger, Port						1	—	C.	BB.17
28D/8323	AS.1242/2E	Attaching parts for 12 W 4137A, Door :— Bolt, 1/4" BSF ... .. .						34	—	C.	
2356	12 W 2765A/1	<b>DOOR</b> , fuel tank No. 1, port (Mod. Ven. 100) (Pre Mod. Ven. 607)						1	—	A.	BB.17
2944	12 W 2766A/1	<b>DOOR</b> , fuel tank No. 1, starboard (Mod. Ven. 100) (Pre Mod. Ven. 607)						1	—	A.	BB.17
	12 W 5803	<b>DOOR</b> , fuel tank No. 1, port (Mod. Ven. 607) ...						1	—		
	12 W 5804	<b>DOOR</b> , fuel tank No. 1, starboard (Mod. Ven. 607)						1	—		
8514	12 W 2817	<b>MOUNTING</b> , R.P. electrical plug ... .. .						2	—	C.	BB.17
28D/8300	AS.1242/1B	Attaching parts for 12 W 2817, Mounting :— Bolt, 2 BA ... .. .						3	—	C.	
6061	12 PT 1725A	<b>SHIELD</b> , for drain holes (Mod. Ven. 442) ...						2	—	C.	BB.17
		Attaching parts for 12 W 2765A/1, 12 W 2766A/1, 12 W 5803 and 12 W 5804, Doors :—									
28D/8327	AS.1242/6E	Bolt, 3/8" BSF ... .. .						4	—	C.	
28D/12108	AS.1242/3G	Bolt, 5/16" BSF ... .. .						2	—	C.	
28D/12128	AS.1242/4G	Bolt, 5/16" BSF ... .. .						102	—	C.	
28M/10331	AGS.2002/G/1	Nut, 5/16" BSF ... .. .						2	—	C.	
28W/12254	SP.13/G	Washer ... .. .						2	—	C.	
7270	12 P 1144A	<b>DOOR</b> , fuel cut off valve at rib No. 1 lower flange, forward (Mod. Ven. 544) (Pre Mod. Ven. 671)						1	—	C.	BB.11
7269	12 P 1143A	<b>DOOR</b> , fuel cut off valve at rib No. 1 lower flange, rear (Mod. Ven. 544) (Pre Mod. Ven. 671)						1	—	C.	BB.11
28D/8307	AS.1242/2C	Attaching parts for 12 P 1144A and 12 P 1143A, Doors :— Bolt, 2 BA ... .. .						1	—	C.	
28L/11035	AGS.2036/C	Lockwasher ... .. .						2	—	C.	
28M/10288	AS.2001/C/1	Nut, 2 BA ... .. .						1	—	C.	
8743	12 W 5691	<b>DOOR</b> , at rib No. 1, lower flange forward and rear (Mod. Ven. 671)						2	—	C.	BB.11
28D/8307	AS.1242/2C	Attaching parts for 12 W 5691, Door :— Bolt, 2 BA ... .. .						2	—	C.	
28L/11035	AGS.2036/C	Lockwasher ... .. .						2	—	C.	
6598	12 W 1157A/3	<b>DUCT</b> , air, outer, Port (Mod. Ven. 454) ... .. .						1	MR	C.	BB.1
6599	12 W 1158A/3	<b>DUCT</b> , air, outer, Starboard (Mod. Ven. 454) ... .. .						1	MR	C.	BB.1
9317	12 W 5387A/ND	<b>BRACKET</b> , duct, air outer (undrilled) ... .. . (Mod. Ven. 454)						2	MR	C.	BB.1
		Attaching parts for 12 W 1157A/3 and 12 W 1158A/3, Ducts :—									
28D/12512	A25/1C	Bolt, 2 BA ... .. .						21	MR	C.	
28M/10288	AGS.2001/C/1	Nut, 2 BA ... .. .						11	MR	C.	
28W/12296	SP.15/C	Washer ... .. .						11	MR	C.	

WING

Ref. No.	Part No.	Nomenclature						No. Off	M.R.	Cl. of St.	Plate No.
		1	2	3	4	5	6				
5896	12 A 557A	<b>DUCT</b> , cannon heating, at drag member in Starboard wing (Mod. Ven. 230)						1	MR	C.	BB.51
7879	J.651 12 W 3803	<b>EDGE</b> , trailing, at wing tip ... .. <b>EYEBOLT</b> , bomb/drop tank release, at nose rib No. 6						QR 1	MR MR	C.	BB.8
28M/10288	AGS.2001/C/1	Attaching parts for 12 W 3803, Eyebolt :—									
1306	12 W 4313	Nut, 2 BA ... ..						1	MR	C.	BB.8
		Washer, cup ... ..						1	MR	C.	BB.8
7865	12 W 3041A	<b>FAIRING</b> , cover, bottom, along fairlead brackets at rib No. 2, Port						1	MR	C.	BB.12
7866	12 W 3042A	<b>FAIRING</b> , cover, bottom, along fairlead brackets at rib No. 2, Starboard						1	MR	C.	BB.12
5856	12 W 3033A	<b>FAIRING</b> , cover, inboard, at rib No. 2, front, Port						1	MR	C.	BB.12
5857	12 W 3034A	<b>FAIRING</b> , cover, inboard, at rib No. 2, front, Starboard						1	MR	C.	BB.12
		Attaching parts for 12 W 3033A and 12 W 3034A, Fairings :—									
28D/13132	AS.3297/1C	Bolt, 2 BA ... ..						8	MR	C.	
340	12 W 3719A	<b>FAIRING</b> , navigation lamp, Port ... ..						1	—	C.	BB.8
341	12 W 3720A	<b>FAIRING</b> , navigation lamp, Starboard ... ..						1	—	C.	BB.8
		Attaching parts for 12 W 3719A and 12 W 3720A, Fairings :—									
28D/8300	AS.1242/1B	Bolt, 4 BA ... ..						8	—	C.	
	12 W 4401A/3	<b>FAIRING</b> , nose air intake, Port ... ..						1	MR		BB.7
	12 W 4402A/3	<b>FAIRING</b> , nose air intake, Starboard ... ..						1	MR		BB.7
12288	12 W 6191A/ND	<b>FAIRING</b> , nose air intake, less boundary layer bleed panel, Port (Mod. Ven. 994)						1	MR	C.	BB.7
12287	12 W 6190A/ND	<b>FAIRING</b> , nose air intake, less boundary layer bleed panel, Starboard (Mod. Ven. 994)						1	MR	C.	BB.7
8788	12 W 4841A/ND	<b>FAIRING</b> , nose air intake, less boundary layer bleed panel, Port (Pre Mod. Ven. 994)						1	MR	C.	BB.7
8789	12 W 4842A/ND	<b>FAIRING</b> , nose air intake, less boundary layer bleed panel, Starboard (Pre Mod. Ven. 994)						1	MR	C.	BB.7
	12 W 719	<b>GUARD</b> , inboard ... ..						1	MR		BB.7
	12 W 717	<b>GUARD</b> , outboard ... ..						1	MR		BB.7
		Attaching parts for 12 W 719 and 12 W 717, Guards :—									
28D/12513	A25/2C	Bolt, 2 BA ... ..						3	MR	C.	
28M/10328	AGS.2002/C/1	Nut, 2 BA ... ..						3	MR	C.	
28W/12296	SP.15/C	Washer ... ..						3	MR	C.	
12185	12 W 6182A	<b>PANEL</b> , boundary layer bleed detachable, Port (Mod. Ven. 994)						1	—	C.	
12186	12 W 6183A	<b>PANEL</b> , boundary layer bleed, detachable, Starboard (Mod. Ven. 994)						1	—	C.	
		Attaching parts for 12 W 6182A and 12 W 6183A, Panels :—									
28D/8306	AS.1242/1C	Bolt, 2 BA ... ..						13	—	C.	
699	12 W 3881A	<b>PANEL</b> , boundary layer bleed, detachable, Port (Pre Mod. Ven. 994)						1	—	C.	BB.7
700	12 W 3882A	<b>PANEL</b> , boundary layer bleed, detachable, Starboard (Pre Mod. Ven. 994)						1	—	C.	BB.7
		Attaching parts for 12 W 3881A and 12 W 3882A, Panels :—									
28D/8306	AS.1242/1C	Bolt, 2 BA ... ..						9	—	C.	
930	12 W 3827A/ND	<b>PLATE</b> , cover, bottom, Port ... ..						1	MR	C.	BB.7
931	12 W 3828A/ND	<b>PLATE</b> , cover, bottom, Starboard ... ..						1	MR	C.	BB.7
		Attaching parts for 12 W 3827A/ND and 12 W 3828A/ND, Plates :—									
28D/8306	AS.1242/1C	Bolt, 2 BA, front ... ..						13	MR	C.	
28D/8307	AS.1242/2C	Bolt, 2 BA, rear and inner ... ..						16	MR	C.	
928	12 W 669A/ND	<b>PLATE</b> , cover, top, Port ... ..						1	MR	C.	BB.7
929	12 W 670A/ND	<b>PLATE</b> , cover, top, Starboard ... ..						1	MR	C.	BB.7
		Attaching parts for 12 W 669A/ND and 12 W 670A/ND, Plates :—									
28D/8306	AS.1242/1C	Bolt, 2 BA, at ribs ... ..						13	MR	C.	
28D/8307	AS.1242/2C	Bolt, 2 BA ... ..						50	MR	C.	

WING

Ref. No.	Part No.	Nomenclature						No Off	M.R.	Cl. of St.	Plate No.
		1	2	3	4	5	6				
	12-2W 185A							1	MR		BB.7
	12-2W 186A							1	MR		BB.7
	12 W 679A							1	MR		BB.7
	12 W 680A							1	MR		BB.7
	12-2W 193A							1	MR		BB.7
	12-2 W194A							1	MR		BB.7
	12 W 677A							1	MR		BB.7
	12 W 678A							1	MR		BB.7
		Attaching parts for 12 W 4401A/3 and 12 W 4402A/3, Fairings :-									
28D/12513	A25/2C	Bolt, 2 BA	...	...	...	...	...	6	MR	C.	
28D/12531	A25/3C	Bolt, 2 BA, at packing and sealing rings	...	...	...	...	...	12	MR	C.	
28D/8307	AS.1242/2C	Bolt, 2 BA, through skin	...	...	...	...	...	24	MR	C.	
825	12 W 3943	Ring, sealing, half, lower	...	...	...	...	...	1	MR	C.	BB.15
824	12 W 3941	Ring, sealing, half, upper	...	...	...	...	...	1	MR	C.	BB.15
28W/12296	SP.15/C	Washer, at packing ring	...	...	...	...	...	6	MR	C.	
344	12 W 3301	<b>FAIRING</b> , stub boom, at undercarriage, Port	...	...	...	...	...	1	—	C.	BB.7
345	12 W 3302	<b>FAIRING</b> , stub boom, at undercarriage, Starboard	...	...	...	...	...	1	—	C.	BB.7
		Attaching parts for 12 W 3301 and 12 W 3302, Fairings :-									
28D/8323	AS.1242/2E	Bolt, 1/4" BSF, at flange	...	...	...	...	...	8	—	C.	
28D/8324	AS.1242/3E	Bolt, 1/4" BSF, at flange	...	...	...	...	...	4	—	C.	
28D/8325	AS.1242/4E	Bolt, 1/4" BSF, at flange	...	...	...	...	...	2	—	C.	
28D/8330	AS.1242/11E	Bolt, 1/4" BSF, at flange	...	...	...	...	...	1	—	C.	
28D/8323	AS.1242/2E	Bolt, 1/4" BSF, at stub boom shell	...	...	...	...	...	5	—	C.	
	12 N 1471	<b>FAIRLEAD</b> , at conduit on tank screens rib No. 1 (Mod. Ven. 302)	...	...	...	...	...	1	—		
		Attaching parts for 12 N 1471, Fairlead :-									
28S/6287	A32/B6	Screw, 4 BA	...	...	...	...	...	2	—	C.	
28W/12305	SP.13/B	Washer	...	...	...	...	...	2	—	C.	
	12 M 155	<b>FAIRLEAD</b> , at false spar in wing tip, for drop tank jettison cable balance	...	...	...	...	...	1	MR		BB.8
		Attaching parts for 12 M 155, Fairlead :-									
28D/12531	A25/3C	Bolt, 2 BA	...	...	...	...	...	2	MR	C.	
28M/10288	AGS.2001/C/1	Nut, 2 BA	...	...	...	...	...	2	MR	C.	
	12 CF 961	<b>FAIRLEAD</b> , grooved, for aileron control cable, in inboard aileron hinge bracket, upper and lower	...	...	...	...	...	2	—		BB.14
	12 CF 963	<b>FAIRLEAD</b> , plate, aileron control cable, in inboard aileron hinge bracket, upper and lower	...	...	...	...	...	2	—		BB.14
		Attaching parts for 12 CF 961 and 12 CF 963, Fairleads (per pair) :-									
28D/8311	AS.1242/7C	Bolt, 2 BA	...	...	...	...	...	1	—	C.	
28D/8314	AS.1242/10C	Bolt, 2 BA	...	...	...	...	...	1	—	C.	
28M/13121	A27/CS	Nut, 2 BA	...	...	...	...	...	2	—	C.	
28P/12462	SP.9/C8	Pin, split	...	...	...	...	...	2	—	C.	
28W/12252	SP.13/C	Washer	...	...	...	...	...	2	—	C.	

WING

Ref. No.	Part No.	Nomenclature						No. Off	M.R.	Cl. of St.	Plate No.
		1	2	3	4	5	6				
	12 W 2831	<b>FAIRLEAD</b> , at outboard channel, at main spar between ribs No. 1 and 2						1	MR		BB.9
	12 W 2839	<b>FAIRLEAD</b> , lower, at inboard channel, at main spar between ribs No. 1 and 2						1	MR		BB.9
	12 W 2835	<b>FAIRLEAD</b> , upper, at inboard channel, at main spar between ribs No. 1 and 2						1	MR		BB.9
	Attaching parts for 12 W 2831, 12 W 2839 and 12 W 2835, Fairleads :—										
28D/12530	A25/6B	Bolt, 4 BA ... ..						3	MR	C.	
28M/10287	AGS.2001/B/1	Nut, 4 BA ... ..						3	MR	C.	
	12 CF 595	<b>FAIRLEAD</b> , lower, on sealing plate rib No. 1, Port (3.85" x 1.35" x 1/4" thick, LFS.21, 23 or 26)						1	—		BB.15
	12 CF 597	<b>FAIRLEAD</b> , lower, on sealing plate rib No. 1, Starboard (3.85" x 1.35" x 1/4" thick, LFS.21, 23 or 26)						1	—		BB.15
	12 CF 599	<b>FAIRLEAD</b> , upper, on sealing plate rib No. 1 (1.5" x 1.05" x 1/4" thick, LFS.21, 23 or 26)						1	—		BB.15
	Attaching parts for 12 CF 595, 12 CF 597 and 12 CF 599, Fairleads :—										
28D/12622	A25/3B	Bolt, 4 BA ... ..						4	—	C.	
28M/10287	AGS.2001/B/1	Nut, 4 BA ... ..						4	—	C.	
28W/12306	SP.15/B	Washer ... ..						4	—	C.	
	12 W 1065	<b>FAIRLEAD</b> , for vent pipe in leading edge, Port ...						9	MR		BB.3
	12 W 1066	<b>FAIRLEAD</b> , for vent pipe in leading edge, Starboard						9	MR		BB.3
	Attaching parts for 12 W 1065 and 12 W 1066, Fairleads :—										
28D/12512	A25/1C	Bolt, 2 BA ... ..						1	MR	C.	
28M/10328	AGS.2002/C/1	Nut, 2 BA ... ..						1	MR	C.	
28W/12252	SP.13/C	Washer ... ..						1	MR	C.	
	12 W 2859	<b>FAIRLEAD</b> , in bottom skin, inboard of rib No. 2, at false spar						1	MR		BB.9
	12 W 2931	<b>FAIRLEAD</b> , No. 1, at rib No. 2, bottom half ...						1	MR		BB.12
	12 W 2933	<b>FAIRLEAD</b> , No. 2, at rib No. 2, bottom half ...						1	MR		BB.12
	Attaching parts for 12 W 2931 and 12 W 2933, Fairleads :										
28D/12515	A25/10C	Bolt, 2 BA ... ..						3	MR	C.	
28M/12929	A27/CP	Nut, 2 BA ... ..						3	MR	C.	
28W/12252	SP.13/C	Washer ... ..						3	MR	C.	
	12 W 2935	<b>FAIRLEAD</b> , No. 3, at rib No. 2, bottom half ...						1	MR		BB.12
	12 W 2937	<b>FAIRLEAD</b> , No. 4, at rib No. 2, bottom half ...						1	MR		BB.12
	12 W 2939	<b>FAIRLEAD</b> , No. 5, at rib No. 2, bottom half ...						1	MR		BB.12
	Attaching parts for 12 W 2935, 12 W 2937 and 12 W 2939, Fairleads :—										
28D/12515	A25/10C	Bolt, 2 BA ... ..						2	MR	C.	
28M/12929	A27/CP	Nut, 2 BA ... ..						2	MR	C.	
28W/12252	SP.13/C	Washer ... ..						2	MR	C.	
	12 W 3103	<b>FAIRLEAD</b> , No. 1, at rib No. 2, top half ...						1	MR		BB.12
	12 W 3105	<b>FAIRLEAD</b> , No. 2, at rib No. 2, top half ...						1	MR		BB.12
	12 W 3107	<b>FAIRLEAD</b> , No. 3, at rib No. 2, top half ...						1	MR		BB.12
9371	12 W 3111	<b>FAIRLEAD</b> , No. 5, at rib No. 2, top half ...						1	MR	C.	BB.12
	Attaching parts for 12 W 3103, 12 W3105, 12 W 3107 and 12 W 3111, Fairleads :—										
28D/8308	AS.1242/3C	Bolt, 2 BA ... ..						2	MR	C.	

**RESTRICTED**  
**AEROFOILS**  
**WING**

Ref. No.	Part No.	Nomenclature						No Off	M.R.	Cl. of St.	Plate No.
		1	2	3	4	5	6				
	12 W 3109	<b>FAIRLEAD</b> , No. 4 at rib No. 2, top half ... ..						1	MR		
		Attaching parts for 12 W 3109, Fairlead :—									
28D/8308	AS.1242/3C	Bolt, 2 BA, lower ... ..						1	MR	C.	
28D/8324	AS.1242/3E	Bolt, 1/2" BSF, upper ... ..						1	MR	C.	
276	12 W 1829	<b>FERRULE</b> , for tie rod in tank bay No. 1 ... ..						2	—	C.	BB.1
275	12 W 537	<b>FERRULE</b> , for tie rods in tank bays Nos. 2, 3 and 4						20	—	C.	
3883	12 W 171	<b>FITTING</b> , drag member, at front top wing/fuselage joint, Port						1	MR	C.	BB.15
3884	12 W 172	<b>FITTING</b> , drag member, at front top wing/fuselage joint, Starboard						1	MR	C.	BB.15
		Attaching parts for 12 W 171 and 12 W 172, Fittings :—									
28D/13196	A25/18L	Bolt, 7/16" BSF ... ..						5	MR	C.	
28D/13193	A25/42G	Bolt, 5/16" BSF, at bracket ... ..						1	MR	C.	
26FC/201	D.00714	Bush, for bolt at bracket ... ..						1	MR	C.	BB.15
28M/13375	A27/GP	Nut, 5/16" BSF, for bolt at bracket ... ..						1	MR	C.	
28M/13553	A27/LP	Nut, 7/16" BSF ... ..						5	MR	C.	
26FC/354	D.00827	Shim, for bolt at bracket ... ..						1	MR	C.	BB.15
28W/12256	SP.13/L	Washer ... ..						5	MR	C.	
28K/549	SP3Y/412	<b>FORK-END</b> , at bomb release ... ..						1	—	C.	
		Attaching parts for SP3Y/412, Fork-end :—									
28L/13140	A27/BT	Locknut, 4 BA ... ..						1	—	C.	
28P/812	SP4Y/A2	Pin, shackle ... ..						1	—	C.	
28P/12587	SP.9/C4	Pin, split ... ..						1	—	C.	
28K/550	SP3Y/412L	<b>FORK-END</b> , L.H. thread, at bomb release ... ..						1	—	C.	
		Attaching parts for SP3Y/412L, Fork-end :—									
28L/13141	A27/BTL	Nut, 4 BA, thin, L.H. thread ... ..						1	—	C.	
204	12 W 3191	<b>FORK-END</b> , for dive brake flap jack ... ..						1	—	C.	BB.11
		Attaching parts for 12 W 3191, Fork-end :—									
205	12 W 3215	Bolt ... ..						1	—	C.	BB.11
26FN/449	24425	Elbow, Tecaemit ... ..						1	—	C.	
28N/9796	SP/21	Nipple, grease ... ..						1	—	C.	
28M/12930	A27/ES	Nut, 1/2" BSF ... ..						1	—	C.	
28P/12462	SP.9/C8	Pin, split ... ..						1	—	C.	
28W/12253	SP.13/E	Washer ... ..						1	—	C.	
	12 W 4587ND	Washer (Make from Ref. No. 28W/12297) ... ..						1	—		BB.11
220	12 W 2851	<b>FORK-END</b> , for flap jack ... ..						1	—	C.	BB.10
		Attaching parts for 12 W 2851, Fork-end :—									
26FC/28	D.001769	Bolt ... ..						1	—	C.	BB.10
28M/13122	A27/GS	Nut, 5/16" BSF ... ..						1	—	C.	
28P/12462	SP.9/C8	Pin, split ... ..						1	—	C.	
28W/12254	SP.13/G	Washer ... ..						1	—	C.	
	12 CF 71A	<b>GUARD</b> , aileron control pulley, Port ... ..						1	—		BB.15
	12 CF 72A	<b>GUARD</b> , aileron control pulley, Starboard ... ..						1	—		BB.15
		Attaching parts for 12 CF 71A and 12 CF 72A, Guards :—									
28D/12511	A25/2B	Bolt, 4 BA ... ..						2	—	C.	
956	12 W 4161	Bolt, aileron stop ... ..						2	—	C.	BB.15
28M/10327	AGS.2002/B/1	Nut, 4 BA ... ..						2	—	C.	
28M/10328	AGS.2002/C/1	Nut, 2 BA ... ..						2	—	C.	
26FC/3623	DHS.69/BB	Shim, 4 BA ... ..						2	—	C.	
28W/12305	SP.13/B	Washer ... ..						2	—	C.	

WING

Ref. No.	Part No.	Nomenclature						No. Off	M.R.	Cl. of St.	Plate No.
		1	2	3	4	5	6				
367	12 W 181	<b>HOUSING</b> , end, for compression leg bearing tube, rear						1	MR	C.	BB.6
368	12 W 183	<b>HOUSING</b> , end, for compression leg bearing tube, front						1	MR	C.	BB.6
369	12 W 185	Attaching parts for 12 W 181 and 12 W 183, Housing :—									
370	12 W 187	Bolt	...	...	...	...	...	2	MR	C.	BB.6
		Nut	...	...	...	...	...	2	MR	C.	BB.6
363	12 W 177	<b>HOUSING</b> , end, for radius rod bearing tube, front, Port						1	MR	C.	BB.6
364	12 W 178	<b>HOUSING</b> , end, for radius rod bearing tube, front, Starboard						1	MR	C.	BB.6
365	12 W 179	<b>HOUSING</b> , end, for radius rod bearing tube, rear, Port						1	MR	C.	BB.6
366	12 W 180	<b>HOUSING</b> , end, for radius rod bearing tube, rear, Starboard						1	MR	C.	BB.6
		Attaching parts for 12 W 177, 12 W 178, 12 W 179 and 12 W 180, Housings :—									
28D/13061	A25/23J	Bolt, 3/8" BSF, with head drilled No. 54 for locking wire						2	MR	C.	
7816	12 W 535	<b>HOUSING</b> , ferrule, for fuel tanks between ribs No. 2 and 5						3	MR	C.	
27M/608	AIR.41474	<b>JACK</b> , dive brake flap, Lockheed (For breakdown see AP.4515F, Vol. 3, Part 1, Sect. 2, Chap. 11)						1	—	A.	BB.11
		Attaching parts for AIR.41474, Jack :—									
206	12 W 3265	Bolt	...	...	...	...	...	1	—	C.	BB.11
28L/14966	A24/NT	Locknut	...	...	...	...	...	1	—	C.	
28M/12930	A27/ES	Nut	...	...	...	...	...	1	—	C.	
28P/12462	SP.9/C8	Pin	...	...	...	...	...	1	—	C.	
28W/12253	SP.13/E	Washer	...	...	...	...	...	1	—	C.	
27M/456	AIR.40010	<b>JACK</b> , flap, Lockheed (For Breakdown see AP.4515F, Vol. 3, Part 1, Sect. 2, Chap 11) (Mod. Ven. 739)						1	—	A.	
		Attaching parts for AIR.40010, Jack :—									
26FC/30	G.0050	Bolt	...	...	...	...	...	1	—	C.	BB.10
26FC/260	D.001772	Locknut	...	...	...	...	...	1	—	C.	BB.10
28N/9796	SP/21	Nipple	...	...	...	...	...	1	—	C.	
28M/12930	A27/ES	Nut	...	...	...	...	...	1	—	C.	
28P/12462	SP.9/C8	Pin	...	...	...	...	...	1	—	C.	
28W/12253	SP.13/E	Washer	...	...	...	...	...	1	—	C.	

WING

Ref. No.	Part No.	Nomenclature						No. Off	M.R.	Cl. of St.	Plate No.
		1	2	3	4	5	6				
5CX/1515	‡	<b>LAMP</b> , landing, type J, in Port wing ... ..						1		A.	
5L/X.954717	‡	<b>FILAMENT</b> , 24 volt, 240 watt, clear ... ..						1	—	B.	
5CX/1516	‡	<b>GLASS</b> , and gasket ... ..						1	—	B.	
5CX/1544	‡	<b>REFLECTOR</b> ... ..						1	—	A.	
5UD/1517	‡	<b>UNIT</b> , operating ... ..						1	—	A.	
	12 W 3709A	<b>LAMP</b> , navigation, and mounting plate, Port ...						1	—		BB.8
	12 W 3710A	<b>LAMP</b> , navigation, and mounting plate, Starboard						1	—		BB.8
5CX/492	‡	<b>LAMP</b> , type A, Port ... ..						1	—	A.	BB.8
5CX/496	‡	<b>LAMP</b> , type A, Starboard ... ..						1	—	A.	BB.8
5CX/494	‡	<b>CAP</b> , for glass ... ..						1	—	B.	
5L/X.952421	‡	<b>FILAMENT</b> , 24 volt, 20 watt, clear ... ..						1	—	B.	
5CX/497	‡	<b>GLASS</b> , green, for Starboard lamp ... ..						1	—	B.	
5CX/493	‡	<b>GLASS</b> , red, for Port lamp ... ..						1	—	B.	
5CX/1955	‡	<b>RING</b> , securing ... ..						1	—	C.	
5CX/490	‡	<b>WASHER</b> , jointing ... ..						1	—	C.	
28M/10326	AGS.2002/A/1	<b>NUT</b> , 6 B.A. for securing lamp ... ..						4	—	C.	
	12 W 3711ND	<b>PLATE</b> , mounting 14 SWG, L.72 ... ..						1	—		BB.8
		Attaching parts for 12 W 3709A and 12 W 3710A, Lamps :—									
28D/12512	A25/1C	Bolt, 2 BA ... ..						2	—	C.	
5K/3389	AS.3360/C4C	<b>LEAD</b> , bonding, at ribs 5 and 10 Port and Starboard						4	—	C.	
		Attaching parts for AS.3360/C4C, Lead :—									
28D/10570	AS.1247/1C	Bolt, 2 BA ... ..						1	—	C.	
28E/14201	AS.3181/18C	Clip ... ..						1	—	C.	
28M/10281	AGS.2001/C/3	Nut, 2 BA ... ..						1	—	C.	
4701	12 CF 857A	<b>LEVER</b> , aileron tab operating, Port ... ..						1	—	C.	BB.13
4702	12 CF 855	<b>SPIGOT</b> , connecting rod ... ..						1	—	C.	BB.13
		Attaching parts for 12 CF 855, Spigot :—									
28D/8343	AS.1248/4C	Bolt, 2 BA ... ..						2	—	C.	
28M/13121	A27/CS	Nut, 2 BA ... ..						2	—	C.	
28P/12462	SP.9/C8	Pin, split ... ..						2	—	C.	
28W/12296	SP.15/C	Washer ... ..						2	—	C.	
4703	12 CF 859	<b>SPIGOT</b> , micro switch lever ... ..						1	—	C.	BB.13
		Attaching parts for 12 CF 859, Spigot :—									
28M/12929	A27/CP	Nut, 2 BA ... ..						1	—	C.	
28W/12296	SP.15/C	Washer ... ..						1	—	C.	
		Attaching parts for 12 CF 857A, Lever :—									
28D/14858	A57/20E	Bolt, 1/2" BSF ... ..						1	—	C.	
28M/13935	A58/ES	Nut, 1/2" BSF ... ..						1	—	C.	
28P/12462	SP.9/C8	Pin, split ... ..						1	—	C.	
28W/12253	SP.13/E	Washer ... ..						1	—	C.	
	12 W 4077A/ND	<b>LEVER</b> , bomb/drop tank release, front at nose rib No. 6						1	MR	—	BB.8
		Attaching parts for 12 W 4077A/ND, Lever :—									
	DHS.94/4/60	Pin ... ..						1	MR	—	

WING

Ref. No.	Part No.	Nomenclature						No. Off	M.R.	Cl. of St.	Plate No.
		1	2	3	4	5	6				
7880	12 W 3807A	<b>LEVER</b> , bomb/drop tank release, rear, at nose rib No. 6, Port						1	MR	C.	BB.8
7881	12 W 3808A	<b>LEVER</b> , bomb/drop tank release, rear, at nose rib No. 6, Starboard						1	MR	C.	BB.8
		Attaching parts for 12 W 3807A and 12 W 3808A, Levers :—									
	DHS.94/4/60	Pin	...	...	...	...	...	1	MR		
28P/813	SP4Y/A3	Pin, shackle	...	...	...	...	...	1	MR	C.	
28P/12462	SP.9/C8	Pin, split	...	...	...	...	...	1	MR	C.	
28W/12305	SP.13/B	Washer	...	...	...	...	...	1	MR	C.	
4705	12 CF 925A/ND	<b>LEVER</b> , complete with aileron sprocket, at false spar, Port						1	—	B.	BB.13
4704	12 CF 926A/ND	<b>LEVER</b> , complete with aileron sprocket, at false spar, Starboard						1	—	B.	BB.13
6493	12 CF 841A	<b>LEVER</b> , connecting rod, Port						1	—	B.	BB.13
6494	12 CF 842A	<b>LEVER</b> , connecting rod, Starboard						1	—	B.	BB.13
27S/136	Skefko 400015	<b>BEARING</b> , ball-race						2	—	B.	
	12 CF 1029	<b>TUBE</b> , distance						1	—		BB.14
6492	12 CF 839	<b>SPROCKET</b>						1	—	C.	BB.13
		Attaching parts for 12 CF 839, Sprocket :—									
28D/8308	AS.1242/3C	Bolt, 2 BA	...	...	...	...	...	6	—	C.	
28M/12929	A27/CP	Nut, 2 BA	...	...	...	...	...	6	—	C.	
		Attaching parts for 12 CF 925A/ND and 12 CF 926A/ND, Levers :—									
4706	12 CF 819	Bolt, special	...	...	...	...	...	1	—	C.	BB.13
6495	12 CF 861A	<b>LEVER</b> , micro switch operating, at false spar, Port						1	—	B.	BB.13
27S/131	Skefko CBS.0	<b>BEARING</b> , ball-race						1	—	B.	
	12 CF 865	<b>BOLT</b> , special						1	—		BB.13
28L/13124	A27/CT	<b>LOCKNUT</b> , 2 BA						1	—	C.	
		Attaching parts for 12 CF 861A, Lever :—									
28D/13401	A30/7C	Bolt, 2 BA	...	...	...	...	...	1	—	C.	
28M/13121	A27/CS	Nut, 2 BA	...	...	...	...	...	1	—	C.	
28P/12462	SP.9/C8	Pin, split	...	...	...	...	...	1	—	C.	
28W/12252	SP.13/C	Washer, under bolt head	...	...	...	...	...	1	—	C.	
28W/12355	SP.16/C	Washer, between bearing and boss	...	...	...	...	...	1	—	C.	
9616	12-4CF 45A	<b>LEVER</b> , servodyne attachment, Port (Mod. Ven. 803)						1	—		BB.14
9617	12-4CF 46A	<b>LEVER</b> , servodyne attachment, Starboard (Mod. Ven. 803)						1	—		BB.14
27S/136	Skefko 400015	<b>BEARING</b> , ball-race						2	—	B.	
	12 CF 1029	<b>TUBE</b> , distance						1	—		BB.13
		Attaching parts for 12-4CF 45A and 12-4CF 46A, Levers :—									
4726	12 CF 567	Bolt, special	...	...	...	...	...	1	—	C.	BB.14
	12 W 4867	<b>LINK</b> , long, for flap indicator transmitter in Starboard wing						1	—	C.	BB.10
	12 W 4869	<b>LINK</b> , short, for flap indicator transmitter in Starboard wing						1	—	C.	BB.10
		Attaching parts for 12 W 4867 and 12 W 4869, Links (per pair) :—									
28D/12513	A25/2C	Bolt, 2 BA	...	...	...	...	...	3	—	C.	
28M/10288	AGS.2001/C/1	Nut, 2 BA	...	...	...	...	...	3	—	C.	
28W/12296	SP.15/C	Washer	...	...	...	...	...	1	—	C.	

WING

Ref. No.	Part No.	Nomenclature						No. Off	M.R.	Cl. of St.	Plate No.
		1	2	3	4	5	6				
11769	12 WF 231A/ND	<b>LINK</b> , torque, for flaps ... ..						2	—	C.	BB.10
216	12 WF 11A	<b>EYE-END</b> , L.H. thread, complete with ball joint						2	MR	C.	BB.10
217	12 WF 12A	<b>EYE-END</b> , R.H. thread, complete with ball joint						2	MR	C.	BB.10
10492	12 WF 221	<b>LINK</b> , torque ... ..						2	MR	C.	BB.10
28L/13028	A27/JT	<b>LOCKNUT</b> , $\frac{3}{8}$ " BSF, thin ... ..						2	MR	C.	
28L/13811	A27/JTL	<b>LOCKNUT</b> , $\frac{3}{8}$ " BSF, thin, L.H. thread ... ..						2	MR	C.	
Attaching parts for 12 WF 231A/ND, Link :—											
28D/12816	A25/7G	Bolt, $\frac{5}{16}$ " BSF, at torque lever ... ..						2	MR	C.	
28M/12930	A27/ES	Nut, $\frac{1}{4}$ " BSF, at spindle on flap ... ..						2	MR	C.	
28M/13122	A27/GS	Nut, $\frac{5}{16}$ " BSF, for torque lever bolt ... ..						2	MR	C.	
28P/12462	SP.9/C8	Pin, split ... ..						4	MR	C.	
28W/12253	SP.13/E	Washer, at spindle on flap ... ..						2	MR	C.	
28W/12324	SP.15/G	Washer, for torque lever bolt ... ..						2	MR	C.	
28F/9584	AGS.1148/B	<b>LOCKNUT</b> , for hydraulic pressure pipe connection at false spar						1	—	C.	
28F/10108	AGS.1148/C	<b>LOCKNUT</b> , for hydraulic return pipe, at false spar						1	—	C.	
28F/10491	AGS.1148/A	<b>LOCKNUT</b> , pipe coupling, at clip on dive brake flap jack						1	—	C.	
26FC/2969	D.003166	<b>LUG</b> , attachment, at front top wing/fuselage joint						1	—	C.	BB.15
Attaching parts for D.003166, Lug :—											
26FC/2967	D.003167	Bolt ... ..						4	—	C.	BB.15
26FC/353	D.002299	Shim ... ..						1	—	C.	BB.15
8865	12 W 291A/2	<b>MEMBER</b> , drag, in leading edge, between ribs No. 1A and 2, Port						1	MR	C.	BB.2
8866	12 W 292A/2	<b>MEMBER</b> , drag, in leading edge, between ribs No. 1A and 2, Starboard						1	MR	C.	BB.2
	12 W 2087	<b>MEMBER</b> , drag, undercarriage diaphragm skin attachment, front, Port						1	MR		BB.16
7831	12 W 2088	<b>MEMBER</b> , drag, undercarriage diaphragm skin attachment, front, Starboard						1	MR	C.	BB.16
Attaching parts for 12 W 2087 and 12 W 2088, Members :—											
28D/12513	A25/2C	Bolt, 2 BA, inboard of rib No. 2 ... ..						1	MR	C.	
28D/12513	A25/3C	Bolt, 2 BA, inboard of rib No. 2 ... ..						2	MR	C.	
28D/12532	A25/4C	Bolt, 2 BA, inboard of rib No. 2 ... ..						2	MR	C.	
28D/12533	A25/5C	Bolt, 2 BA, inboard of rib No. 2 ... ..						1	MR	C.	
7303	DHS.201/4E	Bolt, $\frac{1}{4}$ " BSF, outboard of rib No. 2 ... ..						1	MR	C.	
7304	DHS.201/5E	Bolt, $\frac{1}{4}$ " BSF, outboard of rib No. 2 ... ..						2	MR	C.	
7305	DHS.201/6E	Bolt, $\frac{1}{4}$ " BSF, outboard of rib No. 2 ... ..						3	MR	C.	
28M/12929	A27/CP	Nut, 2 BA, inboard of rib No. 2 ... ..						6	MR	C.	
7310	DHS.202/E	Nut, $\frac{1}{4}$ " BSF, outboard of rib No. 2 ... ..						6	MR	C.	
	12 W 2543	Packing, at outboard end bolt ... ..						1	MR		
7849	12 W 2779ND	Shim, inboard of rib No. 2 ... ..						1	MR	C.	
7850	12 W 2781ND	Shim, outboard of rib No. 2 (if required) ... ..						1	MR	C.	
	12 W 2787ND	Shim, under skin ... ..						1	MR		
28W/12296	SP.15/C	Washer, inboard of rib No. 2 ... ..						6	MR	C.	
28W/12496	SP.15/C	Washer, outboard of rib No. 2 ... ..						5	MR	C.	

AEROFOILS

WING

Ref. No.	Part No.	Nomenclature						No. Off	M.R.	Cl. of St.	Plate No.
		1	2	3	4	5	6				
7829	12 W 2085	<b>MEMBER</b> , drag, undercarriage diaphragm skin attachment, rear, Port						1	MR	C.	BB.16
7830	12 W 2086	<b>MEMBER</b> , drag, undercarriage diaphragm skin attachment, rear, Starboard						1	MR	C.	BB.16
		Attaching parts for 12 W 2085 and 12 W 2086, Members :—									
	DHS.201/5C	Bolt, 2 BA, inboard of rib No. 2 ... ..						6	MR		
7303	DHS.201/4E	Bolt, 3/4" BSF, outboard of rib No. 2 ... ..						2	MR	C.	
7304	DHS.201/5E	Bolt, 3/4" BSF, outboard of rib No. 2 ... ..						2	MR	C.	
7305	DHS.201/6E	Bolt, 3/4" BSF, outboard of rib No. 2 ... ..						2	MR	C.	
	DHS.202/C	Nut, 2 BA, thin, inboard of rib No. 2 ... ..						6	MR		
7310	DHS.202/E	Nut, 3/4" BSF, thin, outboard of rib No. 2 ... ..						6	MR	C.	
	12 W 2543	Packing, at outboard end bolts ... ..						2	MR		
	12 W 2783ND	Shim, inboard of rib No. 2 ... ..						1	MR		
	12 W 2785ND	Shim, outboard of rib No. 2 ... ..						1	MR		
	12 W 2787ND	Shim, under skin ... ..						1	MR		
28W/12296	SP.15/C	Washer ... ..						6	MR	C.	
28W/12496	SP.15/E	Washer ... ..						4	MR	C.	
	12 W 5082A	<b>PANEL</b> , corner, at rib No. 1 and main spar, Starboard						1	MR		BB.20
	12 W 5081A	<b>PANEL</b> , corner, at rib No. 1 and main spar, Port ...						1	MR		BB.20
		Attaching parts for 12 W 5081A and 12 W 5082A, Panels :—									
28D/13132	AS.3297/1C	Bolt, 2 BA ... ..						12	MR	C.	
28D/13461	AS.329-2C	Bolt, 2 BA ... ..						5	MR	C.	
4738	12 W 4955A	<b>PANEL</b> , detachable, aileron inner shroud, top inboard, L.H.						1	—	C.	BB.5
4739	12 W 4956A	<b>PANEL</b> , detachable aileron inner shroud, top inboard, R.H.						1	—	C.	BB.5
	12 W 5167A	<b>BRACKET</b> , support, Port ... ..						1	—		BB.5
	12 W 5168A	<b>BRACKET</b> , support, Starboard ... ..						1	—		BB.5
		Attaching parts for 12 W 4955A and 12 W 4956A, Panels :—									
28D/8306	AS.1242/1C	Bolt, 2 BA ... ..						6	—	C.	
28D/8309	AS.1242/4C	Bolt, 2 BA ... ..						2	—	C.	
	12 W 3055A	<b>PANEL</b> , forward, along rib No. 2, Port ... ..						1	MR		BB.20
	12 W 3056A	<b>PANEL</b> , forward, along rib No. 2, Starboard ... ..						1	MR		BB.20
	12 W 3057A	<b>PANEL</b> , rear, along rib No. 2, Port ... ..						1	MR		BB.12
	12 W 3058A	<b>PANEL</b> , rear, along rib No. 2, Starboard ... ..						1	MR		BB.12
		Attaching parts for 12 W 3055A, 12 W 3056A, 12 W 3057A and 12 W 3058A, Panels :—									
28D/13132	AS.3297/1C	Bolt, 2 BA ... ..						10	MR	C.	
4736	12 W 5017A/ND	<b>PANEL</b> , hinged, aileron inner shroud, bottom inboard, L.H.						1	—	C.	BB.5
4737	12 W 5018A/ND	<b>PANEL</b> , hinged, aileron inner shroud bottom inboard, R.H.						1	—	C.	BB.5
4734	12 W 4991A/ND	<b>PANEL</b> , hinged, aileron inner shroud bottom outboard, L.H.						1	—	C.	BB.5
4735	12 W 4992A/ND	<b>PANEL</b> , hinged, aileron inner shroud bottom outboard, R.H.						1	—	C.	BB.5

**RESTRICTED**  
**AEROFOILS**  
**WING**

Ref. No.	Part No.	Nomenclature						No. Off	M.R.	Cl. of St.	Plate No.
		1	2	3	4	5	6				
3882	12-2W 319	<b>PIN</b> , at rib No. 1/main spar joint, bottom ... ..						1	MR	C.	BB.4
3881	12-2W 321	<b>PIN</b> , at rib No. 1A/main spar joint, bottom ... ..						1	MR	C.	BB.4
		Attaching parts for 12-2W 319 and 12-2W 321, Pins :—									
28M/13122	A27/GS	Nut, $\frac{5}{16}$ " BSF ... ..						1	MR	C.	
28M/13412	A.24/JS	Nut, $\frac{3}{8}$ " BSF ... ..						1	MR	C.	
28P/12462	SP.9/C8	Pin, split ... ..						1	MR	C.	
28W/12253	SP.13/G	Washer ... ..						1	MR	C.	
28W/12500	SP./14/J	Washer ... ..						1	MR	C.	
313	12 W 1431	<b>PIN</b> , at rib No. 1/main spar joint, top ... ..						1	MR	C.	BB.4
		Attaching parts for 12 W 1431, Pin :—									
28M/13123	A27/JS	Nut, $\frac{3}{8}$ " BSF ... ..						1	MR	C.	
28P/12462	SP.9/C8	Pin, split ... ..						1	MR	C.	
28W/12322	SP.16/J	Washer ... ..						1	MR	C.	
314	12 W 2695	<b>PIN</b> , at rib No. 1A/main spar joint, top ... ..						1	MR	C.	BB.4
		Attaching parts for 12 W 2695, Pin :—									
28M/13259	A27/NS	Nut, $\frac{3}{8}$ " BSF ... ..						1	MR	C.	
28P/12463	SP.9/E10	Pin, split ... ..						1	MR	C.	
28W/12443	SP.16/N	Washer ... ..						1	MR	C.	
790	12 A 55A/ND	<b>PIPE</b> , cannon heating, through main spar in Starboard wing						1	MR	C.	BB.15
		Attaching parts for 12 A 55A/ND, Pipe :—									
28D/8300	AS.1242/1B	Bolt, 4 BA, at rib No. 1 ... ..						2	—	C.	
28M/10287	AGS.2001/B/1	Nut, 4 BA, at rib No. 1 ... ..						2	—	C.	
28W/12305	SP.13/B	Washer, at rib No. 1 ... ..						2	—	C.	
704	12 W 3395A/ND	<b>PIPE</b> , dive brake flap up, from flexible pipe to jack, Port						1	—	C.	BB.11
705	12 W 3396A/ND	<b>PIPE</b> , dive brake flap up, from flexible pipe to jack, Starboard						1	—	C.	BB.11
1926	12 S 1061A	<b>PIPE</b> , fuel vent, at rib No. 2, in leading edge ... ..						1	—	C.	BB.1
		Attaching parts for 12 S 1061A, Pipe :—									
28D/12629	A25/8C	Bolt, 2 BA ... ..						1	—	C.	
28D/12536	A25/13C	Bolt, 2 BA ... ..						2	—	C.	
28Q/12091	SP.900/23	Ring, Dowty ... ..						1	—	C.	
28W/12296	SP 15/C	Washer, 2 BA ... ..						3	—	C.	
2852	12 W 4631A	<b>PIPE</b> , fuel vent, in leading edge... ..						1	MR	C.	BB.1
	12 W 5289A	<b>PLATE</b> , aileron shroud, bottom outboard, Port ... ..						1	MR	C.	BB.5
	12 W 5290A	<b>PLATE</b> , aileron shroud, bottom outboard, Starboard ... ..						1	MR	C.	BB.5
	12 W 5283A	<b>PLATE</b> , aileron shroud, top outboard, Port ... ..						1	MR	C.	BB.5
	12 W 5284A	<b>PLATE</b> , aileron, shroud top outboard, Starboard ... ..						1	MR	C.	BB.5
7884	12 W 4025A	<b>PLATE</b> , anchor nut, on spar, for R.P., Port inner ... ..						1	MR	C.	BB.9
7885	12 W 4026A	<b>PLATE</b> , anchor nut, on spar, for R.P., Starboard inner ... ..						1	MR	C.	BB.9
7827	12 W 1885A	<b>PLATE</b> , anchor nut, on spar, for R.P., Port outer ... ..						1	MR	C.	BB.9
7828	12 W 1886A	<b>PLATE</b> , anchor nut, on spar, for R.P., Starboard outer ... ..						1	MR	C.	BB.9
2958	12 PT 1437	<b>PLATE</b> , blanking, for tip tank release unit hole ... ..						1	—	C.	BB.1
	12 W 2029ND	<b>PLATE</b> , clamping, for landing lamp mounting rig, in Port wing						1	MR	C.	BB.1

**RESTRICTED**  
**AEROFOILS**  
**WING**

Ref. No.	Part No.	Nomenclature						No Off.	M.R.	Cl. of St.	Plate No.
		1	2	3	4	5	6				
148	12 W 1846A	<b>PLATE</b> , cover, at aileron centre hinge, Port bottom and Starboard top						2	—	C.	BB.5
147	12 W 1845A	<b>PLATE</b> , cover, at aileron centre hinge, Port top and Starboard bottom						2	—	C.	BB.5
28D/8306	AS.1242/1C	Attaching parts for 12 W 1846A and 12 W 1845A, Plates :—									
		Bolt, 2 BA ... ..						4	—	C.	
151	12 W 1930A	<b>PLATE</b> , cover, at aileron outer hinge, Port bottom and Starboard top						2	—	C.	BB.5
150	12 W 1929A	<b>PLATE</b> , cover, at aileron outer hinge, Port top and Starboard bottom						2	—	C.	BB.5
		Attaching parts for 12 W 1930A and 12 W 1929A, Plates :—									
28D/8306	AS.1242/1C	Bolt, 2 BA ... ..						4	—	C.	
2957	12 W 4859	<b>PLATE</b> , cover, for fuel pipes at wing tip ... ..						1	—	C.	BB.1
28D/8300	AS.1242/1B	Attaching parts for 12 W 4859, Plate :—									
		Bolt, 4 BA ... ..						12	—	C.	
2959	12 W 4863	<b>PLATE</b> , cover, fuel connections at wing tip ... ..						1	—	C.	BB.1
1931	12 W 4385A	<b>PLATE</b> , cover, for fuel pipes at wing tip, L.H. ... ..						1	—	C.	BB.18
1932	12 W 4386A	<b>PLATE</b> , cover, for fuel pipes at wing tip, R.H. ... ..						1	—	C.	BB.18
271	12 W 3219	<b>PLATE</b> , cover, in bottom skin, aft of main spar, between ribs No. 7 and 8, in Starboard wing						1	—	C.	BB.17
267	12 W 3201	<b>PLATE</b> , cover, in bottom skin, forward of main spar, between ribs No. 5 and 7						2	—	C.	BB.17
		Attaching parts for 12 W 3219 and 12 W 3201, Plates:—									
28D/8307	AS.1242/2C	Bolt, 2 BA ... ..						20	—	C.	
268	12 W 3203	<b>PLATE</b> , cover, in bottom, skin, aft of main spar, between ribs No. 10 and 11, Starboard						1	—	C.	BB.17
		Attaching parts for 12 W 3203, Plate :—									
28D/8376	AS.1243/2C	Bolt, 2 BA ... ..						24	—	C.	
272	12 W 3497	<b>PLATE</b> , cover, in bottom skin, aft of undercarriage diaphragm, between ribs No. 2 and 3						1	—	C.	BB.17
		Attaching parts for 12 W 3497, Plate :—									
28D/8306	AS.1242/1C	Bolt, 2 BA ... ..						12	—	C.	
28D/8307	AS.1242/2C	Bolt, 2 BA ... ..						6	—	C.	
269	12 W 3205	<b>PLATE</b> , cover, in bottom skin, port (2) and starboard (3)						5	—	C.	BB.17
270	12 W 3217	<b>PLATE</b> , cover, in bottom skin, forward of main spar, between ribs No. 11 and 12						1	—	C.	BB.17
		Attaching parts for 12 W 3205 and 12 W 3217, Plates:—									
28D/8307	AS.1242/2C	Bolt, 2 BA ... ..						12	—	C.	
1290	12 W 4263	<b>PLATE</b> , cover, in bottom skin, between rib 13 and end rib						1	—	C.	BB.17
		Attaching parts for 12 W 4263, Plate :—									
28D/8307	AS.1242/2C	Bolt, 2 BA ... ..						28	—	C.	
266	12 W 3199	<b>PLATE</b> , cover, in bottom skin, forward of undercarriage diaphragm between ribs No. 2 and 3 R.H. only						1	—	C.	BB.17
		Attaching parts for 12 W 3199, Plate :—								×	
28D/8307	AS.1242/2C	Bolt, 2 BA ... ..						20	—	C.	
	12 W 5419A	<b>PLATE</b> , cover, bottom skin, forward of undercarriage diaphragm, between ribs No. 2 and 3 L.H. only						1	—		
		Attaching parts for 12 W 5419A Plate :—									
28D/8307	AS.1242/2C	Bolt, 2 BA ... ..						20	—	C.	

## AEROFOILS

## WING

Ref. No.	Part No.	Nomenclature						No. Off	M.R.	Cl. of St.	Plate No.
		1	2	3	4	5	6				
	12 W 4283	<b>PLATE</b> , reinforcing, at wing tip drop tank release mechanism, on top skin						1	MR		
	12 W 5133A/ND	<b>PLATE</b> , reinforcing, complete with anchor nuts, in bottom skin, forward of false spar, between ribs No. 7 and 8, in Port wing						1	MR		
	12 W 5134A/ND	<b>PLATE</b> , reinforcing, complete with anchor nuts, in bottom skin, forward of false spar, between ribs No. 7 and 8, in Starboard wing						1	MR		
	12 W 1005	<b>PLATE</b> , reinforcing, at wing tip drop tank release mechanism, on bottom skin						1	MR		
	12 W 2363A/ND	<b>PLATE</b> , reinforcing, complete with anchor nuts, at aerial in Starboard wing						1	MR		
	12 W 2239A/ND	<b>PLATE</b> , reinforcing, complete with anchor nuts, in bottom skin, aft of main spar, between ribs No. 7 and 8, in Starboard wing						1	MR		
	12 W 4875A/ND	<b>PLATE</b> , reinforcing, complete with anchor nuts, in bottom skin, aft of main spar, between ribs No. 10 and 11, in Starboard wing						1	MR		
	12 W 2433A/ND	<b>PLATE</b> , reinforcing, complete with anchor nuts, in bottom skin, aft of main spar, forward of undercarriage diaphragm between ribs No. 2 and 3, Port						1	MR		
	12 W 2434A/ND	<b>PLATE</b> , reinforcing, complete with anchor nuts, in bottom skin, aft of main spar, forward of undercarriage diaphragm between ribs No. 2 and 3, Starboard						1	MR		
	12 W 2015A/ND	<b>PLATE</b> , reinforcing, complete with anchor nuts, in bottom skin, between ribs No. 1 and 2, forward of main spar, Port						1	MR		
	12 W 2016A/ND	<b>PLATE</b> , reinforcing, complete with anchor nuts, in bottom skin, between ribs No. 1 and 2, forward of main spar, Starboard						1	MR		
	12 W 1753A/ND	<b>PLATE</b> , reinforcing, complete with anchor nuts, in bottom skin, between ribs No. 5 and 6, Port						1	MR		
	12 W 1754A/ND	<b>PLATE</b> , reinforcing, complete with anchor nuts, in bottom skin, between ribs No. 5 and 6, Starboard						1	MR		
	12 W 1757A/ND	<b>PLATE</b> , reinforcing, complete with anchor nuts, in bottom skin, between ribs No. 6 and 7, Port						1	MR		
	12 W 1758A/ND	<b>PLATE</b> , reinforcing, complete with anchor nuts, in bottom skin, between ribs No. 6 and 7, Starboard						1	MR		
	12 W 1791A/ND	<b>PLATE</b> , reinforcing, complete with anchor nuts, in bottom skin, forward of main spar, between ribs No. 11 and 12, Port						1	MR		
	12 W 1792A/ND	<b>PLATE</b> , reinforcing, complete with anchor nuts, in bottom skin, forward of main spar, between ribs No. 11 and 12, Starboard						1	MR		
	12 W 2241A/ND	<b>PLATE</b> , reinforcing, complete with anchor nuts, in bottom skin, at wing tip, forward of main spar						1	MR		

WING

Ref. No.	Part No.	Nomenclature						No. Off	M.R.	Cl. of St.	Plate No.	
		1	2	3	4	5	6					
	12 W 1491A/ND	PLATE,	reinforcing,	complete	with	anchor	nuts,	in	1	MR		
	12 W 1492A/ND	PLATE,	reinforcing,	complete	with	anchor	nuts,	in	1	MR		
	12 W 1481A/ND	PLATE,	reinforcing,	complete	with	anchor	nuts,	in	1	MR		
	12 W 1482A/ND	PLATE,	reinforcing,	complete	with	anchor	nuts,	in	1	MR		
	12 W 1479A/ND	PLATE,	reinforcing,	complete	with	anchor	nuts,	in	1	MR		
	12 W 1480A/ND	PLATE,	reinforcing,	complete	with	anchor	nuts,	in	1	MR		
	12 W 1483A/ND	PLATE,	reinforcing,	complete	with	anchor	nuts,	in	1	MR		
	12 W 1484A/ND	PLATE,	reinforcing,	complete	with	anchor	nuts,	in	1	MR		
	12 W 1857A/ND	PLATE,	reinforcing,	complete	with	anchor	nuts,	in	1	MR		
	12 W 1858A/ND	PLATE,	reinforcing,	complete	with	anchor	nuts,	in	1	MR		
	12 W 3727A/ND	PLATE,	reinforcing,	complete	with	anchor	nuts,	in	1	MR		
	12 W 3728A/ND	PLATE,	reinforcing,	complete	with	anchor	nuts,	in	1	MR		
	12 W 2191ND	PLATE,	reinforcing,	in	top	skin	at	wheel	1	MR		
	12 W 2192ND	PLATE,	reinforcing,	in	top	skin	at	wheel	1	MR		
	12 W 2017ND	PLATE,	reinforcing,	in	bottom	skin,	between	ribs	1	MR		
	12 W 2018ND	PLATE,	reinforcing,	in	bottom	skin,	between	ribs	1	MR		
	12 W 2027ND	PLATE,	reinforcing,	in	bottom	skin,	between	ribs	1	MR		
	12 W 3525ND	PLATE,	reinforcing,	in	bottom	skin,	forward	of	1	MR		
	12 W 2401ND	PLATE,	reinforcing,	in	top	skin,	inboard	of	1	MR		
	12 W 2402ND	PLATE,	reinforcing,	in	top	skin,	inboard	of	1	MR		
	12-4 W 5A	PLATE,	sealing,	rib	No.	1,	Port	(Mod.	1	—		
	12-4 W 7A	PLATE,	sealing,	rib	No.	1,	Starboard	(Mod.	1	—		
9599	12 W 5676	PLATE,	cover,	Port	(Mod.	Ven.	596)	...	1	—	C.	
9598	12 W 5675	PLATE,	cover,	Starboard	(Mod.	Ven.	596)	...	1	—	C.	
		Attaching parts for 12 W 5676 and 12 W 5675, Plates:—										
28D/12512	A25/1C	Bolt,	2	BA	...	...	...	...	1	—	C	
28D/12252	SP.13/C	Washer,	2	BA	...	...	...	...	1	—	C	
		Attaching parts for 12-4 W 5A and 124 W 7A, Plates:—										
28D/12528	A25/1B	Bolt,	4	BA	...	...	...	...	10	—	C.	
28D/8300	AS.1242/1B	Bolt,	4	BA	...	...	...	...	26	—	C.	
28D/8301	AS.1242/2B	Bolt,	4	BA	...	...	...	...	2	—	C.	
28M/10287	AGS.2001/B/1	Nut,	4	BA	...	...	...	...	22	—	C.	
28W/2306	SP.15/B	Washer	...	...	...	...	...	...	32	—	C.	

WING

Ref. No.	Part No.	Nomenclature						No Off	M.R.	Cl. of St.	Plate No.
		1	2	3	4	5	6				
3948	12 W 191A	<b>PLATE</b> , side, for jack trunnion at inner hinge bracket, outboard flap, outboard Port and inboard Starboard						1	MR	C.	BB.10
3949	12 W 192A	<b>PLATE</b> , side, for jack trunnion at inner hinge bracket, outboard flap, outboard, Starboard and inboard Port						1	MR	C.	BB.10
		Attaching parts for 12 W 191A and 12 W 192A, Plates (per pair) :—									
28D/12547	A25/15E	Bolt, $\frac{1}{4}$ " BSF ... ..						4	—	C.	
28M/12928	A27/EP	Nut, $\frac{1}{4}$ " BSF ... ..						4	—	C.	
28W/12297	SP.16/E	Washer ... ..						4	—	C.	
	12 W 2441	<b>PLATE</b> , stiffening, in bottom skin, at rib No. 2 and main spar boom, Port						1	MR		
	12 W 2442	<b>PLATE</b> , stiffening, in bottom skin, at rib No. 2 and main spar boom, Starboard						1	MR		
	12 W 2263A	<b>PLATE</b> , support, for G.4F compass detector unit in Starboard wing						1	MR		BB.16
		Attaching parts for 12 W 2263A, Plate :—									
	DHS.201/1C	Bolt, 2 BA ... ..						8	MR		
28M/10288	AGS.2001/C/1	Nut, 2 BA ... ..						8	MR	C.	
28W/12296	SP.15/C	Washer ... ..						8	MR	C.	
1353	12-2W 105	<b>PLATE</b> , wing attachment, at main spar, bottom, Port						1	MR	C.	BB.4
1354	12-2W 106	<b>PLATE</b> , wing attachment, at main spar, bottom, Starboard						1	MR	C.	BB.4
		Attaching parts for 12-2W 105 and 12-2W 106, Plates :—									
252	12 W 101	Bolt, inner, at end post ... ..						2	MR	C.	BB.4
842	12 W 4019	Bolt, outer, at end post ... ..						1	MR	C.	BB.4
843	12 W 4021	Bolt, outer ... ..						5	MR	C.	BB.4
844	12 W 4023	Bolt, outer, at R.P. mounting ... ..						2	—	C.	
28L/14966	A24/NT	Locknut, $\frac{1}{8}$ " BSF, for outer bolts ... ..						5	MR	C.	
28M/13273	A24/JP	Nut, $\frac{3}{16}$ " BSF, for inner bolts at end post ... ..						2	MR	C.	
28M/13282	A24/NP	Nut, $\frac{1}{8}$ " BSF, for outer bolts at end post ... ..						1	MR	C.	
28W/12322	SP.16/J	Washer ... ..						2	MR	C.	
28W/12443	SP.16/N	Washer ... ..						6	MR	C.	
1355	12-2W 127	<b>PLATE</b> , wing attachment, at main spar, top, Port						1	MR	C.	BB.4
1356	12-2W 128	<b>PLATE</b> , wing attachment, at main spar, top, Starboard						1	MR	C.	BB.4
		Attaching parts for 12-2W 127 and 12-2W 128, Plates :—									
254	12 W 105	Bolt, inner ... ..						4	MR	C.	BB.4
1477	12 W 4249	Bolt, outer ... ..						7	MR	C.	BB.4
28L/14966	A24/NT	Locknut, $\frac{1}{8}$ " BSF, for outer bolts ... ..						7	MR	C.	
28M/14438	A24/LP	Nut, $\frac{7}{16}$ " BSF, for inner bolts ... ..						4	MR	C.	
28W/12443	SP.16/N	Washer ... ..						11	MR	C.	
125	12 CF 63A	<b>PULLEY</b> , aileron control, Port ... ..						1	MR	B.	BB.15
126	12 CF 64A	<b>PULLEY</b> , aileron control, Starboard ... ..						1	MR	B.	BB.15
27S/143	I.132499	<b>BEARING</b> , ball-race, Skefko ... ..						1	—	B.	BB.15
		Attaching parts for 12 CF 63A and 12 CF 64A, Pulleys :—									
26FC/24	D.00348	Bolt, $\frac{3}{8}$ " BSF ... ..						1	—	C.	BB.15
7814	12 W 521	<b>PYLON</b> , bomb/drop tank support, in leading edge, Port						1	MR	B.	BB.8
7815	12 W 522	<b>PYLON</b> , bomb/drop tank support, in leading edge, Starboard						1	MR	B.	BB.8

AEROFOILS

WING

Ref. No.	Part No.	Nomenclature						No. Off	M.R.	Cl. of St.	Plate No.
		1	2	3	4	5	6				
28D/8301 28M/10287 28W/12306	12 W 4945A	RIB, at aileron sprocket bracket, Port	...	...	...	...	1	—		BB.5	
	12 W 4946A	RIB, at aileron sprocket support bracket, Starboard	...	...	...	...	1	—		BB.5	
	12 W 4939	BLOCK, rubbing, Port	...	...	...	...	1	—		BB.5	
	12 W 4940	BLOCK, rubbing, Starboard	...	...	...	...	1	—		BB.5	
	AS.1242/2B	BOLT, 4 BA	...	...	...	...	4	—	C.		
	AGS.2001/B/1	NUT, 4 BA	...	...	...	...	4	—	C.		
330	12 W 3713A	RIB, attachment, for navigation lamp, L.H.	...	...	...	...	1	MR	C.	BB.8	
	12 W 3714A	RIB, attachment, for navigation lamp, R.H.	...	...	...	...	1	MR		BB.8	
6015	12 W 5147	RIB, end, No. 14, front portion...	...	...	...	...	1	—	C.	BB.2	
5604	12 W 4275A	RIB, end, No. 14, rear portion, Port	...	...	...	...	1	—	C.	BB.2	
5605	12 W 4276A	RIB, end, No. 14, rear portion, Starboard	...	...	...	...	1	—	C.	BB.2	
835 28D/8300 28M/10287	12 W 5565	RIB, No. 2 inboard of aileron centre hinge in shroud, Port	...	...	...	...	1	MR			
	12 W 5566	RIB, No. 2 inboard of aileron centre hinge in shroud, Starboard	...	...	...	...	1	MR			
	12 W 3967A	RIB, outboard of aileron centre hinge in shroud, Port	...	...	...	...	1	MR		BB.5	
	12 W 3968A	RIB, outboard of aileron centre hinge in shroud, Starboard	...	...	...	...	1	MR		BB.5	
836 28D/8300 28M/10287	12 W 3963	BLOCK, rubbing	...	...	...	...	1	—	C.	BB.5	
	AS.1242/1B	BOLT, 4 BA	...	...	...	...	4	—	C.		
	AGS.2001/B/1	NUT, 4 BA	...	...	...	...	4	—	C.		
836 28D/8300 28M/10287	12 W 3971A	RIB, inboard of aileron outer hinge in shroud, Port	...	...	...	...	1	MR		BB.5	
	12 W 3972A	RIB, inboard of aileron outer hinge in shroud, Starboard	...	...	...	...	1	MR		BB.5	
	12 W 3977	BLOCK, rubbing	...	...	...	...	1	—	C.	BB.5	
	AS.1242/1B	BOLT, 4 BA	...	...	...	...	4	—	C.		
	AGS.2001/B/1	NUT, 4 BA	...	...	...	...	4	—	C.		
	12 W 1917A	RIB, outboard of aileron outer hinge in shroud	...	...	...	...	1	MR		BB.5	
	12 W 461	RIB, leading edge, No. 3, inboard, Port	...	...	...	...	1	MR		BB.3	
	12 W 462	RIB, leading edge, No. 3, inboard, Starboard...	...	...	...	...	1	MR		BB.3	
	12 W 463	RIB, leading edge, No. 3, outboard, Port	...	...	...	...	1	MR		BB.3	
	12 W 464	RIB, leading edge, No. 3, outboard, Starboard	...	...	...	...	1	MR		BB.3	
	12 W 453	RIB, leading edge, No. 4, inboard, Port	...	...	...	...	1	MR		BB.3	
	12 W 454	RIB, leading edge, No. 4, inboard, Starboard...	...	...	...	...	1	MR		BB.3	
12 W 455	RIB, leading edge, No. 4, outboard, Port	...	...	...	...	1	MR		BB.3		
12 W 456	RIB, leading edge, No. 4, outboard, Starboard	...	...	...	...	1	MR		BB.3		
12 W 327	RIB, leading edge, No. 5, Port	...	...	...	...	1	MR		BB.3		
12 W 328	RIB, leading edge, No. 5, Starboard	...	...	...	...	1	MR		BB.3		
12 W 1017	RIB, leading edge, No. 6, Port	...	...	...	...	1	MR		BB.3		
12 W 1018	RIB, leading edge, No. 6, Starboard	...	...	...	...	1	MR		BB.3		
12 W 881	RIB, leading edge, No. 7, Port	...	...	...	...	1	MR		BB.3		
12 W 882	RIB, leading edge, No. 7, Starboard	...	...	...	...	1	MR		BB.3		
12 W 515	RIB, leading edge, No. 8, inboard, Port	...	...	...	...	1	MR				
12 W 516	RIB, leading edge, No. 8, inboard, Starboard...	...	...	...	...	1	MR				
12 W 517	RIB, leading edge, No. 8, outboard, Port	...	...	...	...	1	MR				
12 W 518	RIB, leading edge, No. 8, outboard, Starboard	...	...	...	...	1	MR				
12 W 469	RIB, leading edge, No. 9, inboard, Port	...	...	...	...	1	MR				
12 W 470	RIB, leading edge, No. 9, inboard, Starboard...	...	...	...	...	1	MR				
12 W 471	RIB, leading edge, No. 9, outboard, Port	...	...	...	...	1	MR				
12 W 472	RIB, leading edge, No. 9, outboard, Starboard	...	...	...	...	1	MR				
12 W 499	RIB, leading edge, No. 10, inboard, Port	...	...	...	...	1	MR				
12 W 500	RIB, leading edge, No. 10, inboard, Starboard	...	...	...	...	1	MR				
12 W 501	RIB, leading edge, No. 10, outboard, Port	...	...	...	...	1	MR				
12 W 502	RIB, leading edge, No. 10, outboard, Starboard	...	...	...	...	1	MR				
12 W 445	RIB, leading edge, No. 11, Port	...	...	...	...	1	MR				
12 W 446	RIB, leading edge, No. 11, Starboard	...	...	...	...	1	MR				

WING

Ref. No.	Part No.	Nomenclature						No. Off	M.R.	Cl. of St.	Plate No.
		1	2	3	4	5	6				
	12 W 319A/1	<b>RIB</b> , nose, No. 2, Port ... ..						1	MR		BB.3
	12 W 320A/1	<b>RIB</b> , nose, No. 2, Starboard ... ..						1	MR		BB.3
	12 W 547	<b>FITTING</b> , attachment to main spar, inboard, lower, Port						1	MR		BB.3
	12 W 548	<b>FITTING</b> , attachment to main spar, inboard, lower, Starboard						1	MR		BB.3
	12 W 2991	<b>FITTING</b> , attachment to main spar, outboard, lower, Port						1	MR		BB.3
	12 W 2992	<b>FITTING</b> , attachment to main spar, outboard, lower, Starboard						1	MR		BB.3
	12 W 543	<b>FITTING</b> , attachment to main spar, inboard, upper, Port						1	MR		BB.3
	12 W 544	<b>FITTING</b> , attachment to main spar, inboard, upper, Starboard						1	MR		BB.3
	12 W 2989	<b>FITTING</b> , attachment to main spar, outboard, upper, Port						1	MR		BB.3
	12 W 2990	<b>FITTING</b> , attachment to main spar, outboard, upper, Starboard						1	MR		BB.3
		Attaching parts for 12 W 547, 12 W 548, 12 W 2991, 12 W 2992, 12 W 543, 12 W 544, 12 W 2989 and 12 W 2990, Fittings (per pair) :—									
28D/10742	AS.1242/5G	Bolt, $\frac{5}{16}$ " BSF ... ..						8	MR	C.	
28M/13375	A27/GP	Nut, $\frac{5}{16}$ " BSF ... ..						8	MR	C.	
	12 W 1371	<b>LUG</b> , attachment, for drag member, Port upper and Starboard lower						1	MR		BB.15
	12 W 1372	<b>LUG</b> , attachment, for drag member, Starboard upper and Port lower						1	MR		BB.15
		Attaching parts for 12 W 1371 and 12 W 1372, Lugs :—									
28D/8323	AS.1242/2E	Bolt, $\frac{1}{4}$ " BSF ... ..						2	MR	C.	
28M/12930	A27/ES	Nut, $\frac{1}{4}$ " BSF ... ..						2	MR	C.	
28W/12253	SP.13/E	Washer ... ..						2	MR	C.	
	12 W 325A	<b>RIB</b> , nose, No. 5, Port ... ..						1	MR		BB.3
	12 W 326A	<b>RIB</b> , nose, No. 5, Starboard ... ..						1	MR		BB.3
	12 W 1099	<b>FITTING</b> , attachment to main spar, inboard, upper, Port						1	MR		BB.3
	12 W 1100	<b>FITTING</b> , attachment to main spar, inboard, upper, Starboard						1	MR		BB.3
	12 W 1097	<b>FITTING</b> , attachment, to main spar outboard, upper, Port						1	MR		BB.3
	12 W 1098	<b>FITTING</b> , attachment to main spar, outboard, upper, Starboard						1	MR		BB.3
		Attaching parts for 12 W 1099, 12 W 1100, 12 W 1097 and 12 W 1098, Fittings (per pair) :—									
28D/8311	AS.1242/7C	Bolt, 2 BA ... ..						3	MR	C.	
28D/8313	AS.1242/9C	Bolt, 2 BA ... ..						1	MR	C.	
28D/10168	AS.1242/11C	Bolt, 2 BA ... ..						1	MR	C.	
28D/8328	AS.1242/7E	Bolt, $\frac{1}{4}$ " BSF ... ..						3	MR	C.	
28D/8329	AS.1242/9E	Bolt, $\frac{1}{2}$ " BSF ... ..						1	MR	C.	
28D/8330	AS.1242/11E	Bolt, $\frac{3}{4}$ " BSF ... ..						1	MR	C.	
28M/12929	A27/CP	Nut, 2 BA ... ..						5	MR	C.	
28M/12928	A27/EP	Nut, $\frac{1}{4}$ " BSF ... ..						5	MR	C.	
	12 W 2601ND	Shim ... ..						2	MR		
28W/12252	SP.13/C	Washer ... ..						5	MR	C.	
28W/12253	SP.13/E	Washer ... ..						5	MR	C.	

WING

Ref. No.	Part No.	Nomenclature						No. Off	M.R.	Cl. of St.	Plate No.
		1	2	3	4	5	6				
	12 W 2999							1	MR		BB.3
	12 W 3000							1	MR		BB.3
	12 W 2997							1	MR		BB.3
	12 W 2998							1	MR		BB.3
								Attaching parts for 12 W 2999, 12 W 3000, 12 W 2997 and 12 W 2888, Fittings (per pair) :—			
28D/8326	AS.1242/5E							4	MR	C.	
28M/12928	A27/EP							4	MR	C.	
	12 W 1489ND							1	MR		
	12 W 1487ND							1	MR		
	12 W 1485ND							2	MR		
28W/12253	SP.13/E							4	MR	C.	
	12 W 883A							1	MR		BB.2
	12 W 884A							1	MR		BB.2
	12 W 2993							1	MR		BB.3
	12 W 2994							1	MR		BB.3
								Attaching parts for 12 W 2993 and 12 W 2994, Fittings :—			
28D/9326	AS.1882/3E							5	MR	C.	
28M/12928	A27/EP							5	MR	C.	
28W/12253	SP.13/E							5	MR	C.	
	12 W 2995							1	MR		BB.3
	12 W 2996							1	MR		BB.3
	12 W 447A							1	MR		BB.2
	12 W 448A							1	MR		BB.2
	12 W 337A							1	MR		BB.2
	12 W 338A							1	MR		BB.2
	12 W 339A							1	MR		
	12 W 340A							1	MR		
	12 W 5483A/2							1	MR		BB.4
	12 W 5484A/2							1	MR		BB.4
1963	12 EC 827							1	—	C.	BB.4
								Attaching parts for 12 EC 827, Bracket :—			
28D/12566	A25/6C							1	—	C.	
28D/12543	A25/6E							1	—	C.	
28M/10288	AGS.2001/C/1							1	—	C.	
28M/10290	AGS.2001/E/1							1	—	C.	
	12 W 3401							1	MR		BB.4
	12 W 3402							1	MR		BB.4

WING

Ref. No.	Part No.	Nomenclature						No. Off	M.R.	Cl. of St.	Plate No.
		1	2	3	4	5	6				
	12 W 3403	<b>BRACKET</b> , reinforcing, for cowling fastener, lower rear, Port						1	MR		BB.4
	12 W 3404	<b>BRACKET</b> , reinforcing, for cowling fastener, lower rear, Starboard						1	MR		BB.4
	Attaching parts for 12 W 3401, 12 W 3402, 12 W 3403 and 12 W 3404, Brackets :—										
28D/12533	A25/5C	Bolt, 2 BA						4	MR	C.	
28M/12929	A27/CP	Nut, 2 BA						4	MR	C.	
28W/12252	SP.13/C	Washer						8	MR	C.	
4854	12 W 3491	<b>BRACKET</b> , reinforcing, for cowling fasteners, upper rear, Port						1	MR	C.	BB.4
4855	12 W 3492	<b>BRACKET</b> , reinforcing, for cowling fastener, upper rear, Starboard						1	MR	C.	BB.4
	Attaching parts for 12 W 3491 and 12 W 3492, Brackets :—										
28D/12533	A25/5C	Bolt, 2 BA						2	MR	C.	
28D/12566	A25/6C	Bolt, 2 BA						2	MR	C.	
28M/12929	A27/CP	Nut, 2 BA						4	MR	C.	
28W/12252	SP.13/C	Washer						8	MR	C.	
	12 EC 1243A/ND	<b>BRACKET</b> , tie-rod, L.H.						1	—		BB.4
	12 EC 1244A/ND	<b>BRACKET</b> , tie-rod, R.H.						1	—		BB.4
28D/12533	A25/5C	<b>BOLT</b> , 2 BA						2	—	C.	
2886	12 EC 1051	<b>BRACKET</b> , tie-rod, upper centre, rear						1	—	C.	BB.4
	12 EC 965ND	<b>BRACKET</b> , mounting, tie-rod upper centre undrilled (required to make Part No. 12 EC 1055, Bracket)						1	—		BB.4
	12 EC 967ND	<b>BRACKET</b> , tie-rod, attachment upper centre rear L.H. undrilled (required to make Part No. 12 EC 1053, Bracket)						1	MR		BB.4
	12 EC 968ND	<b>BRACKET</b> , tie-rod, attachment upper centre rear, R.H. undrilled (required to make Part No. 12 EC 1054, Bracket)						1	MR		BB.4
28M/10288	AGS.2001/C/1	<b>NUT</b> , 2 BA						2	—	C.	
28W/12252	SP.13/C	<b>WASHER</b>						2	—	C.	
	Attaching parts for 12 EC 1243A/ND and 12 EC 1244A/ND, Brackets :—										
28D/8311	AS.1242/7C	Bolt, 2 BA						2	MR	C.	
28D/8307	AS.1242/2C	Bolt, 2 BA						2	MR	C.	
	12 W 267	<b>BRACKET</b> , stringer, at rib No. 1, Port						6	MR		BB.9
	12 W 268	<b>BRACKET</b> , stringer, at rib No. 1, Starboard						6	MR		BB.9
382	12 EC 111	<b>BRACKET</b> , tie-rod anchor, at bottom joint fitting, Port						1	MR	C.	BB.4
383	12 EC 112	<b>BRACKET</b> , tie-rod anchor, at bottom joint fitting, Starboard						1	MR	C.	BB.4
	Attaching parts for 12 EC 111 and 12 EC 112, Brackets :—										
28D/8326	AS.1242/5E	Bolt, 1/2" BSF						1	MR	C.	
386	12 EC 347A	<b>BRACKET</b> , tie-rod anchor, lower, at bottom butt plate, Port						1	MR	C.	BB.4

WING

Ref. No.	Part No.	Nomenclature						No. Off	M.R.	Cl. of St.	Plate No.
		1	2	3	4	5	6				
387	12 EC 348A	<b>BRACKET</b> , tie-rod anchor, lower, at bottom butt plate, Starboard						1	MR	C.	BB.4
		Attaching parts for 12 EC 347A and 12 EC 348A, Brackets :—									
28D/12566	A25/6C	Bolt, 2 BA	...	...	...	...	4	MR	C.		
28M/12929	A27/CP	Nut, 2 BA	...	...	...	...	4	MR	C.		
28W/12252	SP.13/C	Washer	...	...	...	...	4	MR	C.		
384	12 EC 335A	<b>BRACKET</b> , tie-rod anchor, lower centre rear, Port						1	MR	C.	
385	12 EC 336A	<b>BRACKET</b> , tie-rod anchor, lower centre rear, Starboard						1	MR	C.	
		Attaching parts for 12 EC 335A and 12 EC 336A, Brackets :—									
28D/12531	A25/3C	Bolt, 2 BA	...	...	...	...	4	MR	C.		
28M/12929	A27/CP	Nut, 2 BA	...	...	...	...	4	MR	C.		
28W/12252	SP.13/C	Washer	...	...	...	...	4	MR	C.		
378	12 EC 97A	<b>BRACKET</b> , tie-rod anchor lower rear, Port						1	MR	C.	BB.4
379	12 EC 98A	<b>BRACKET</b> , tie-rod anchor lower rear, Starboard						1	MR	C.	BB.4
		Attaching parts for 12 EC 97A and 12 EC 98A, Brackets :—									
28D/12531	A25/3C	Bolt, 2 BA	...	...	...	...	4	MR	C.		
28M/10288	AGS.2001/C/1	Nut, 2 BA	...	...	...	...	4	MR	C.		
1961	12 EC 825	<b>BRACKET</b> , tie-rod anchor, upper rear, Port						1	MR	C.	BB.4
1962	12 EC 826	<b>BRACKET</b> , tie-rod anchor, upper rear, Starboard						1	MR	C.	BB.4
		Attaching parts for 12 EC 825 and 12 EC 826, Brackets :—									
28D/8308	AS.1242/3C	Bolt, 2 BA	...	...	...	...	2	—	C.		
28M/10288	AGS.2001/C/1	Nut, 2 BA	...	...	...	...	2	—	C.		
28W/12252	SP.13/C	Washer	...	...	...	...	2	—	C.		
28G/3813	AGS.797/D	<b>EYE-BOLT</b> , 2 BA, lower						1	—	C.	
28G/3814	AGS.797/E	<b>EYE-BOLT</b> , 2 BA, upper						2	—	C.	
	12 W 119	<b>FITTING</b> , lower joint, Port						1	MR		BB.4
	12 W 120	<b>FITTING</b> , lower joint, Starboard						1	MR		BB.4
		Attaching parts for 12 W 119 and 12 W 120, Fittings :—									
28D/13100	A30/5E	Bolt, 1/2" BSF	...	...	...	...	8	MR	C.		
28D/11737	AS.2504/6E	Bolt, 1/2" BSF	...	...	...	...	2	MR	C.		
28L/11071	AGS.2035/E	Lockwasher	...	...	...	...	2	MR	C.		
28M/12928	A27/EP	Nut, 1/2" BSF	...	...	...	...	8	MR	C.		
	12 W 21	<b>FITTING</b> , upper joint, Port						1	MR		BB.4
	12 W 22	<b>FITTING</b> , upper joint, Starboard						1	MR		BB.4
		Attaching parts for 12 W 21 and 12 W 22, Fittings :—									
28D/11508	AS.2504/8E	Bolt, 1/2" BSF	...	...	...	...	9	MR	C.		
28G/3826	AGS.798/G	Eye-bolt, BSF	...	...	...	...	1	MR	C.		
28M/12928	A27/EP	Nut, 1/2" BSF	...	...	...	...	10	MR	C.		
380	12 EC 99A	<b>LUG</b> , tie-rod attachment, Port						4	MR	C.	BB.4
381	12 EC 100A	<b>LUG</b> , tie-rod attachment, Starboard						4	MR	C.	BB.4
		Attaching parts for 12 EC 99A and 12 EC 100A, Lugs :—									
28D/12531	A25/3C	Bolt, 2 BA	...	...	...	...	2	MR	C.		
28M/10288	AGS.2001/C/1	Nut, 2 BA	...	...	...	...	2	MR	C.		

WING

Ref. No.	Part No.	Nomenclature						No Off	M.R.	Cl. of St.	Plate No.
		1	2	3	4	5	6				
	12 W 3437A							1	MR		BB.4
	12 W 3637A							1	MR		BB.4
	12 W 3503							1	MR		BB.4
	12 W 3504							1	MR		BB.4
28D/12532	A25/4C							6	MR	C.	
28D/12533	A25/5C							4	MR	C.	
28M/12929	A27/CP							10	MR	C.	
28V/12252	SP.13/C							10	MR	C.	
5643	12 EC 1077A							2	—	C.	BB.4 BB.16
28D/8507	AS.1242/5C							4	—	C.	
	J.645							QR	—		
	J.646							QR	—		
	12 W 35A							1	MR		BB.4
	12 W 36A							1	MR		BB.4
	12 W 2709							1	MR		BB.4
	12 W 2710							1	MR		BB.4
28D/11808	AS.2504/4E							6	MR	C.	
28M/12928	A27/EP							6	MR	C.	
	12-2W 317							1	MR		BB.4
	12-2W 318							1	MR		BB.4
28D/11808	AS.2504/4E							8	MR	C.	
28M/12928	A27/EP							8	MR	C.	
	12 W 3731A							1	MR		BB.2
	12 W 3743A							1	MR		BB.2
28D/12512	A25/1C							13	MR	C.	
	12 W 4209							1	MR		BB.2
	12 W 4210							1	MR		BB.2
2341	12 W 873A							1	MR	C.	BB.3
	12-3W 97A							1	MR		
10298	12 W 874A							1	MR	C.	BB.3
	12 W 4415A							1	MR		BB.3
	12-3W 95A							1	MR		
	12 W 4416A							1	MR		BB.3
	12 W 4417							1	MR		BB.3
	12 W 4418							1	MR		BB.3
	12 W 4419							1	MR		BB.3
	12 W 4420							1	MR		BB.3

**RESTRICTED**  
**AEROFOILS**  
**WING**

Ref. No.	Part No.	Nomenclature						No. Off	M.R.	Cl. of St.	Plate No.
		1	2	3	4	5	6				
	12 W 355A	<b>RIB</b> , No. 3, centre, Port ... ..						1	MR		BB.3
	12 W 356A	<b>RIB</b> , No. 3, centre, Starboard ... ..						1	MR		BB.3
	12 W 1763	<b>BLOCK</b> , packing, front lower ... ..						1	MR		BB.16
		Attaching parts for 12 W 1763, Block :—									
28D/8309	AS.1242/4C	Bolt, 2 BA ... ..						4	MR	C.	
28M/12929	A27/CP	Nut, 2 BA ... ..						4	MR	C.	
28W/12324	SP.15/G	Washer ... ..						4	MR	C.	
	12 W 1765	<b>BLOCK</b> , packing, front upper, Port ... ..						1	MR		BB.16
	12 W 1766	<b>BLOCK</b> , packing, front upper, Starboard ... ..						1	MR		BB.16
		Attaching parts for 12 W 1765 and 12 W 1766, Blocks :—									
7308	DHS.201/7G	Bolt, $\frac{5}{16}$ " BSF, front ... ..						2	MR	C.	
28D/9755	AS.1242/7G	Bolt, $\frac{5}{16}$ " BSF, rear ... ..						2	MR	C.	
28L/13326	A.27/GT	Locknut, $\frac{5}{16}$ " BSF, rear ... ..						2	MR	C.	
7311	DHS.202/G	Nut, $\frac{5}{16}$ " BSF, thin, front ... ..						2	MR	C.	
	12 W 2511ND	Shim ... ..						1	MR		
28W/12347	SP.16/G	Washer, front ... ..						2	MR	C.	
28W/12324	SP.15/G	Washer, rear ... ..						2	MR	C.	
11042	12 W 1769	<b>BLOCK</b> , packing, rear lower, Port ... ..						1	MR	C.	BB.16
11043	12 W 1770	<b>BLOCK</b> , packing, rear lower, Starboard ... ..						1	MR	C.	BB.16
		Attaching parts for 12 W 1769 and 12 W 1770, Blocks :—									
28D/10742	AS.1242/5G	Bolt, $\frac{5}{16}$ " BSF ... ..						1	MR	C.	
28M/13375	A27/GP	Nut, $\frac{5}{16}$ " BSF ... ..						1	MR	C.	
28W/12347	SP.16/G	Washer ... ..						1	MR	C.	
	12 W 1767	<b>BLOCK</b> , packing, rear upper, Port... ..						1	MR		BB.16
	12 W 1768	<b>BLOCK</b> , packing, rear upper, Starboard ... ..						1	MR		BB.16
		Attaching parts for 12 W 1767 and 12 W 1768, Blocks :—									
7308	DHS.201/7G	Bolt, $\frac{5}{16}$ " BSF ... ..						4	MR	C.	
7311	DHS.202/G	Nut, $\frac{5}{16}$ " BSF, thin ... ..						4	MR	C.	
	12 W 2513ND	Shim ... ..						1	MR		
28W/12324	SP.15/G	Washer ... ..						4	MR	C.	
	12 W 2413	<b>BRACKET</b> , bracing, at stiffener for wheel door jack, upper, Port						1	MR		BB.6
	12 W 2414	<b>BRACKET</b> , bracing, at stiffener for wheel door jack, upper, Starboard						1	MR		BB.6
	12 W 2415	<b>BRACKET</b> , bracing, at stiffener for wheel door jack, lower, Port						1	MR		BB.6
	12 W 2416	<b>BRACKET</b> , bracing, at stiffener for wheel door jack, lower, Starboard						1	MR		BB.6
		Attaching parts for 12 W 2413, 12 W 2414, 12 W 2415 and 12 W 2416, Brackets :—									
28D/12570	A25/11E	Bolt, $\frac{1}{4}$ " BSF ... ..						2	MR	C.	
28M/12928	A27/EP	Nut, $\frac{1}{4}$ " BSF ... ..						2	MR	C.	
28W/12297	SP.16/E	Washer ... ..						2	MR	C.	

WING

Ref. No.	Part No.	Nomenclature						No Off	M.R.	Cl. of St.	Plate No.
		1	2	3	4	5	6				
312	12 W 2419							1	MR	C.	BB.6
		<b>SPIGOT</b> , for wheel door jack ... ..									
		Attaching parts for 12 W 2419, Spigot :—									
28D/12543	A25/6E							2	MR	C.	
28D/12639	A25/6G							2	MR	C.	
28M/12928	A27/EP							2	MR	C.	
28M/13375	A27/GP							2	MR	C.	
28W/12297	SP.16/E							2	MR	C.	
28W/12347	SP.16/G							2	MR	C.	
	12 W 1945A/1							1	MR		BB.3
	12 W 1946/A1							1	MR		BB.3
	12 W 1335A/1							1	MR		BB.3
	12 W 1336A/1							1	MR		BB.3
258	12 W 1643							1	MR	C.	BB.6
259	12 W 1644							1	MR	C.	BB.6
		<b>BRACKET</b> , hinge, for wheel door, front, Port ...									
		<b>BRACKET</b> , hinge, for wheel door port, Starboard									
		Attaching parts for 12 W 1643 and 12 W 1644,									
		Brackets :—									
28D/12817	A25/8G							3	MR	C.	
28L/15258	A24/GT							3	MR	C.	
28W/12324	SP.15/G							3	MR	C.	
	12 W 1645							1	MR	C.	BB.6
261	12 W 1646							1	MR	C.	BB.6
		<b>BRACKET</b> , hinge, for wheel door rear, Port ...									
		<b>BRACKET</b> , hinge, for wheel door rear, Starboard									
		Attaching parts for 12 W 1645 and 12 W 1646,									
		Brackets :—									
28D/8312	AS.1242/8C							1	MR	C.	
28L/12983	A24/CT							1	MR	C.	
28W/12296	SP.15/C							1	MR	C.	
	12 W 297A							1	MR		BB.3
	12 W 298A							1	MR		BB.3
	12-3W 77							1	MR		BB.3
	12-3W 78							1	MR		BB.3
	12 W 1153A							1	MR		BB.2
	12 W 1154A							1	MR		BB.2
	12 W 1135A							1	MR		BB.2
	12 W 1136A							1	MR		BB.2
	12 W 1093A							1	MR		BB.2
	12 W 1094A							1	MR		BB.2
	12 W 1075A							1	MR		BB.2
	12 W 1076A							1	MR		BB.2
	12 W 1079A							1	MR		BB.2
	12 W 1080A							1	MR		BB.2
	12 W 3031A							1	MR		BB.2
	12 W 3032A							1	MR		BB.2
	12 W 4285							1	MR		BB.2
5CX/1518	†							1	MR	B.	
		<b>RIG</b> , mounting, complete with blanking plate, and									
		fixing plate for landing lamp in Port									
		wing									
393	12 W 2365							1	—	C.	BB.1
10311	12 4CF 33A							1	—	B.	BB.1
		<b>RING</b> , packing, under aerial in Starboard wing ...									
		<b>ROD</b> , connecting, servodyne lever to aileron ...									
		(Mod. Ven. 810)									
10312	12 4CF 35A							1	—	C.	BB.14
28N/13623	CJ3							1	—	C.	
		<b>EYE-END JOINT</b> , self aligning ... ..									
10312	12 4CF 37A							1	—	C.	BB.14
28N/13623	CJ3							1	—	C.	
		<b>EYE-END JOINT</b> , self aligning ... ..									

WING

Ref. No.	Part No.	Nomenclature						No. Off.	M.R.	Cl. of St.	Plate No.
		1	2	3	4	5	6				
28M/14440	A58/JT	<b>LOCKNUT</b> , $\frac{3}{8}$ " BSF ... ..						1	—	C.	
28D/15136	A57/10G	Attaching parts for 12 4CF 33A, Rod :—									
10314	12 4CF 43	Bolt, $\frac{5}{16}$ " BSF ... ..						1	—	C.	
28M/14537	A58/GS	Bush ... ..						4	—	C.	
28P/12462	SP.9/C8	Nut, $\frac{5}{16}$ " BSF ... ..						1	—	C.	
28W/12254	SP.13/G	Pin, split ... ..						1	—	C.	
		Washer ... ..						1	—	C.	
4712	12 CF 835A	<b>ROD</b> , connecting, Servodyne to sprocket lever ...						1	—	A.	BB.13
28R/13507	Hoffmann CF2A	<b>BEARING</b> , eye-end ... ..						1	—	A.	
4713	12 CF 815	<b>FORK-END</b> ... ..						1	—	C.	BB.13
28L/13326	A27/GT	<b>LOCKNUT</b> , $\frac{5}{16}$ " BSF, for eye-end bearing ...						1	—	C.	
28L/13464	A27/GTL	<b>LOCKNUT</b> , $\frac{5}{16}$ " BSF, for fork-end ...						1	—	C.	
	12 CF 837	<b>ROD</b> , connecting ... ..						1	—		BB.13
		Attaching parts for 12 CF 835A, Rod :—									
28D/13401	A30/7C	Bolt, 2 BA ... ..						1	—	C.	
28D/14856	A57/9G	Bolt, $\frac{5}{16}$ " BSF ... ..						1	—	C.	
28M/13121	A27/CS	Nut, 2 BA ... ..						1	—	C.	
28M/14537	A58/GS	Nut, $\frac{5}{16}$ " BSF ... ..						1	—	C.	
28P/12462	SP.9/C8	Pin, split ... ..						2	—	C.	
28W/12252	SP.13/C	Washer, at eye-end bearing ... ..						1	—	C.	
28U/4051	SP8Y/1	<b>ROD</b> , tension, at bomb release ... ..						1	—	C.	
9831	12 P 1035A/ND	<b>ROD</b> , tie for Teddington Valve FKG/A/30 on rib No. 1						1	MR	B.	BB.11
	or										
9832	12 P 1037A/ND	<b>ROD</b> , tie, for Saunders Valve HG/100/H.10 on rib No. 1						1	MR	B.	BB.11
	or										
9833	12 P 1039A/ND	<b>ROD</b> , tie, for Teddington or Saunders Valves on rib No. 1						2	MR	B.	BB.11
26FC/2142	L.001249	<b>CUP</b> , ball ... ..						2	—	C.	BB.11
26FC/2143	L.001252	<b>HOUSING</b> , L.H. ... ..						1	—	C.	BB.11
26FC/2144	L.001253	<b>HOUSING</b> , R.H. ... ..						1	—	C.	BB.11
26FC/2131	L.001248	<b>JOINT</b> , ball ... ..						2	—	C.	BB.11
28L/13454	A27/ETL	<b>LOCKNUT</b> , $\frac{1}{4}$ " BSF ... ..						1	—	C.	
26FC/2145	L.001251	<b>PLUG</b> , joint ... ..						2	—	C.	BB.11
2931	12 P 539ND	<b>ROD</b> , tie, $\frac{1}{4}$ " dia. x 4-0" long, $\frac{1}{4}$ " BSF, thread x 0-75" long, L.H. and R.H., Specn. S.1, or S.93 (For 12 P 1035A/ND only)						1	—	C.	BB.11
2932	12 P 899ND	<b>ROD</b> , tie, $\frac{1}{4}$ " dia. x 3-10" long, $\frac{1}{4}$ " BSF thread x 0-75" long, L.H. and R.H., Specn. S.1 or S.93 (For 12 P 1037A/ND only)						1	—	C.	BB.11
2933	12 P 537ND	<b>ROD</b> , tie, $\frac{1}{4}$ " dia. x 3-65" long, $\frac{1}{4}$ " BSF thread x 0-75" long, L.H. and R.H. Specn. S.1 or S.93 (For 12 P 1039A/ND only)						1	—	C.	BB.11
26FC/2146	L.001250	<b>SPRING</b> , joint ... ..						2	—	C.	BB.11
		Attaching parts for 12 P 1035A/ND, 12 P 1037A/ND and 12 P 1039A/ND, Rods :—									
28M/10288	AGS.2001/C/1	Nut, 2 BA ... ..						2	—	C.	
28W/12245	SP.10/C	Washer ... ..						2	—	C.	
	12 W 2717A	<b>SCREEN</b> , tank, at false spar, between ribs No. 5 and 7, Port						1	MR		BB.20
	12 W 2718A	<b>SCREEN</b> , tank, at false spar, between ribs No. 5 and 7, Starboard						1	MR		BB.20
	12 W 2711A	<b>SCREEN</b> , tank, at fuel tank door landing plate along main spar, Port						1	MR		BB.20
	12 W 2712A	<b>SCREEN</b> , tank, at fuel tank door landing plate along main spar, Starboard						1	MR		BB.20
	12 W 3027A	<b>SCREEN</b> , tank, at main spar, between ribs No. 1 and 2, Port						1	MR		BB.20

WING

Ref. No.	Part No.	Nomenclature						No. Off	M.R.	Cl. of St.	Plate No.
		1	2	3	4	5	6				
	12 W 3028A	<b>SCREEN</b> , tank, at main spar, between ribs No. 1 and 2, Starboard						1	MR		BB.20
		Attaching parts for 12 W 3027A and 12 W 3028A, Screens :—									
28D/13132	AS.3297/1C	Bolt, 2 BA	...	...	...	...	...	11	MR	C.	
28D/13461	AS.3297/2C	Bolt, 2 BA	...	...	...	...	...	2	MR	C.	
28D/13134	AS.3297/7C	Bolt, 2 BA	...	...	...	...	...	4	MR	C.	
	12 W 2023	<b>SCREEN</b> , tank, at nose rib No. 5, to main spar joint, bottom inboard, Port						1	MR		BB.20
	12 W 2024	<b>SCREEN</b> , tank, at nose rib No. 5, to main spar joint, bottom inboard, Starboard						1	MR		BB.20
		Attaching parts for 12 W 2023 and 12 W 2024, Screens :—									
28D/8341	AS.1248/1C	Bolt, 2 BA	...	...	...	...	...	2	MR	C.	
28D/8342	AS.1248/2C	Bolt, 2 BA	...	...	...	...	...	2	MR	C.	
	12 W 2021	<b>SCREEN</b> , tank, at nose rib No. 5 to main spar joint, top inboard, Port						1	MR		BB.20
	12 W 2022	<b>SCREEN</b> , tank, at nose rib No. 5 to main spar joint, top inboard, Starboard						1	MR		BB.20
		Attaching parts for 12 W 2021 and 12 W 2022, Screens :—									
28D/8341	AS.1248/1C	Bolt, 2 BA	...	...	...	...	...	2	MR	C.	
28D/8342	AS.1248/2C	Bolt, 2 BA	...	...	...	...	...	2	MR	C.	
	12 W 2089	<b>SCREEN</b> , tank, at nose rib No. 7 to main spar joint, bottom, Port						1	MR		BB.20
	12 W 2090	<b>SCREEN</b> , tank, at nose rib No. 7 to main spar joint, bottom, Starboard						1	MR		BB.20
	12 W 2091	<b>SCREEN</b> , tank, at nose rib No. 7 to main spar joint, top, Port						1	MR		BB.20
	12 W 2092	<b>SCREEN</b> , tank, at nose rib No. 7 to main spar joint, top, Starboard						1	MR		BB.20
		Attaching parts for 12 W 2089, 12 W 2090, 12 W 2091 and 12 W 2092, Screens :—									
28D/8341	AS.1248/1C	Bolt, 2 BA	...	...	...	...	...	4	MR	C.	
	12 W 5071A/ND	<b>SCREEN</b> , tank, at rib No. 1, Port (Mod. Ven. 450)						1	MR		BB.20
	12 W 5072A/ND	<b>SCREEN</b> , tank, at rib No. 1, Starboard (Mod. Ven. 450)						1	MR		BB.20
	12 W 3113A	<b>SCREEN</b> , tank, at rib No. 2 and false spar, Port ...						1	MR		BB.20
	12 W 3114A	<b>SCREEN</b> , tank, at rib No. 2 and false spar, Starboard						1	MR		BB.20
		Attaching parts for 12 W 3113A and 12 W 3114A, Screens :—									
28D/13132	AS.3297/1C	Bolt, 2 BA	...	...	...	...	...	7	MR	C.	
	12 W 2063	<b>SCREEN</b> , tank, at rib No. 2 to main spar joint, upper, Port						1	MR		BB.20
	12 W 2064	<b>SCREEN</b> , tank, at rib No. 2 to main spar joint, upper, Starboard						1	MR		BB.20
	12 W 2065	<b>SCREEN</b> , tank, at rib No. 2 to main spar joint, lower, Port						1	MR		BB.20
	12 W 2066	<b>SCREEN</b> , tank, at rib No. 2 to main spar joint, lower, Starboard						1	MR		BB.20
		Attaching parts for 12 W 2063, 12 W 2064, 12 W 2065 and 12 W 2066, Screens :—									
28D/8342	AS.1248/2C	Bolt, 2 BA	...	...	...	...	...	2	MR	C.	
28D/9588	AS.1248/3C	Bolt, 2 BA	...	...	...	...	...	1	MR	C.	

AEROFOILS

WING

Ref. No.	Part No.	Nomenclature						No. Off	M.R.	Cl. of St.	Plate No.	
		1	2	3	4	5	6					
28D/8342	12 W 3547	SCREEN, tank, at rib No. 3 to main spar joint, Port						1	MR		BB.20	
	12 W 3548	SCREEN, tank, at rib No. 3 to main spar joint, Starboard						1	MR		BB.20	
	AS.1248/2C	Attaching parts for 12 W 3547 and 12 W 3548, Screens :- Bolt, 2 BA ... ..						3	MR	C.		
28D/8341	12 W 2341	SCREEN, tank, at rib No. 4 to main spar joint, Port						1	MR		BB.20	
	12 W 2342	SCREEN, tank, at rib No. 4 to main spar joint, Starboard						1	MR		BB.20	
	AS.1248/1C	Attaching parts for 12 W 2341 and 12 W 2342, Screens :- Bolt, 2 BA ... ..						3	MR	C.		
28D/8341	12 W 2541	SCREEN, tank, at rib No. 5 to false spar joint, Port						1	MR		BB.20	
	12 W 2542	SCREEN, tank, at rib No. 5 to false spar joint, Starboard						1	MR		BB.20	
	AS.1248/1C	Attaching parts for 12 W 2541 and 12 W 2542, Screens :- Bolt, 2 BA ... ..						2	MR	C.		
28D/8342	AS.1248/2C	Bolt, 2 BA ... ..						1	MR	C.		
28D/8342	12 W 2539	SCREEN, tank, at rib No. 5 to main spar joint, bottom outboard, Port						1	MR		BB.20	
	12 W 2540	SCREEN, tank, at rib No. 5 to main spar joint, bottom outboard, Starboard						1	MR		BB.20	
	AS.1248/2C	Attaching parts for 12 W 2539 and 12 W 2540, Screens :- Bolt, 2 BA ... ..						4	MR	C.		
28D/8341	12 W 2515	SCREEN, tank, at rib No. 5 to main spar joint, top outboard, Port						1	MR		BB.20	
	12 W 2516	SCREEN, tank, at rib No. 5 to main spar joint, top outboard, Starboard						1	MR		BB.20	
	AS.1248/1C	Attaching parts for 12 W 2515 and 12 W 2516, Screens :- Bolt, 2 BA ... ..						4	MR	C.		
28D/8306	12 W 5433A/ND	SCREEN, tank, between ribs No. 1 and 1B, Port						1	MR		BB.20	
	12 W 5434A/ND	SCREEN, tank, between ribs No. 1 and 1B, Starboard						1	MR		BB.20	
	12 W 2689A/ND	SCREEN, tank, between ribs No. 1B and 2, Port						1	MR		BB.20	
	12 W 2690A/ND	SCREEN, tank, between ribs No. 1B and 2, Starboard						1	MR		BB.20	
	12 W 2453A/ND	SCREEN, tank, between ribs No. 5 and 6, Port ...						1	MR		BB.20	
	12 W 2454A/ND	SCREEN, tank, between ribs No. 5 and 6, Starboard						1	MR		BB.20	
	12 W 2471A/ND	SCREEN, tank, between ribs No. 6 and 7, Port ...						1	MR		BB.20	
	12 W 2472A/ND	SCREEN, tank, between ribs No. 6 and 7, Starboard						1	MR		BB.20	
	12 W 1591A/ND	SCREEN, tank, between ribs No. 2 and 3 in leading edge, Port						1	MR		BB.20	
	12 W 1592A/ND	SCREEN, tank, between ribs No. 2 and 3 in leading edge, Starboard						1	MR		BB.20	
	1139	12 W 4217A/ND	SCREEN, tank, between nose rib No. 5 and main spar, inboard, Port (Mod. Ven. 16, Part "A")						1	MR	C.	BB.20
	1140	12 W 4218A/ND	SCREEN, tank, between nose rib No. 5 and main spar, inboard, Starboard (Mod. Ven. 16, Part "A")						1	MR	C.	BB.20
	28D/8306	AS.1242/1C	Attaching parts for 12 W 4217A/ND and 12 W 4218A/ND, Screens :- Bolt, 2 BA ... ..						5	MR	C.	
28D/8341	AS.1248/1C	Bolt, 2 BA ... ..						3	MR	C.		
28M/10288	AGS.2001/C/1	Nut, 2 BA ... ..						8	MR	C.		
28W/12296	SP.15/C	Washer ... ..						8	MR	C.		

WING

Ref. No.	Part No.	Nomenclature						No. Off	M.R.	Cl. of St.	Plate No.
		1	2	3	4	5	6				
	12 W 1609A/ND	SCREEN, tank, between ribs No. 3 and 4 in leading edge, Port						1	MR		BB.20
	12 W 1610A/ND	SCREEN, tank, between ribs No. 3 and 4 in leading edge, Starboard						1	MR		BB.20
	12 W 1617A/ND	SCREEN, tank, between ribs No. 4 and 5 in leading edge, Port						1	MR		BB.20
	12 W 1618A/ND	SCREEN, tank, between ribs No. 4 and 5 in leading edge, Starboard						1	MR		BB.20
	12 W 1519A/ND	SCREEN, tank, between ribs No. 7 and 8 in leading edge, Port						1	MR		BB.20
	12 W 1520A/ND	SCREEN, tank, between ribs No. 7 and 8 in leading edge, Starboard						1	MR		BB.20
	12 W 1527A/ND	SCREEN, tank, between ribs No. 8 and 9 in leading edge, Port						1	MR		BB.20
	12 W 1528A/ND	SCREEN, tank, between ribs No. 8 and 9 in leading edge, Starboard						1	MR		BB.20
	12 W 1531A/ND	SCREEN, tank, between ribs No. 9 and 10 in leading edge, Port						1	MR		BB.20
	12 W 1532A/ND	SCREEN, tank, between ribs No. 9 and 10 in leading edge, Starboard						1	MR		BB.20
	12 W 1535A/ND	SCREEN, tank, between ribs No. 10 and 11 in leading edge, Port						1	MR		BB.20
	12 W 1536A/ND	SCREEN, tank, between ribs No. 10 and 11 in leading edge, Starboard						1	MR		BB.20
26FC/352	D.001664	SHACKLE, for flap jack fork end ... ..						1	—	C.	BB.10
		Attaching parts for D.001664, Shackle :—									
219	12 W 2849	Bolt ... ..						1	—	C.	
28N/9796	SP/21	Nipple, grease ... ..						1	—	C.	
28M/13123	A27/JS	Nut, 3/8" BSF ... ..						1	—	C.	
28P/12462	SP.9/C8	Pin, split ... ..						1	—	C.	
28W/12255	SP.13/J	Washer ... ..						1	—	C.	
7137	12 W 2107A	SHELL, stub boom, Port... ..						1	MR	C.	BB.7
26FC/1989	D.002477	BRACKET, mounting, for air speed indicator drain traps						1	MR	C.	BB.7
26FC/1990	D.002478A	BRACKET, support, for air speed indicator pipe clamp block						1	MR	C.	BB.7
6442	12 W 2108A	SHELL, stub boom, bottom, Starboard ... ..						1	MR	C.	BB.7
	12 W 2093A	SHELL, stub boom, top, Port ... ..						1	MR		BB.7
	12 W 2094A	SHELL, stub boom, top, Starboard ... ..						1	MR		BB.1
346	12 W 3767A/ND	PLATE, cover, and retaining cable, in stub boom shell, for access to lifting attachment, Port						1	—	C.	BB.1
701	12 W 3768A/ND	PLATE, cover, and retaining cable, in stub boom shell, for access to lifting attachment, Starboard						1	—	C.	BB.1
6061	12 PT 1725A	SHIELD, for drain holes ... ..						4	—	C.	
	12 W 3999ND	SHIM, at curved plate in aileron inner shroud ...						QR	MR		
	12 W 4005ND	SHIM, at curved plate in aileron outer shroud ...						QR	MR		
	12 W 2819ND	SHIM, at rib No. 2/main spar joint, top ...						1	MR		
	12 W 2821ND	SHIM, at rib No. 2/main spar joint, bottom ...						1	MR		
	12 W 2533ND	SHIM, at rib No. 5/main spar joint, bottom, inboard						1	MR		
	12 W 2535ND	SHIM, at rib No. 5/main spar joint, bottom, outboard						1	MR		

WING

Ref. No.	Part No.	Nomenclature						No. Off	M.R.	Cl. of St.	Plate No.
		1	2	3	4	5	6				
11406	12-3W 179A/1	<b>SHROUD</b> , dive brake flap, Port (Mod. Ven. 753) ...						1	MR	B.	BB.2
11407	12-3W 180A/1	<b>SHROUD</b> , dive brake flap, Starboard (Mod. Ven. 753)						1	MR	B.	BB.2
	12-3W 247A/ND	<b>BRACKET</b> , main hinge ... ..						1	MR		BB.3
		Attaching parts for 12-3W 247A/ND, Bracket :-									
28D/12513	A25/2C	Bolt, 2 BA ... ..						8	MR	C.	
28D/12544	A25/8E	Bolt, 1/4" BSF, inboard ... ..						2	MR	C.	
28D/12542	A25/5E	Bolt, 1/4" BSF, outboard... ..						2	MR	C.	
28M/10288	AGS.2001/C/1	Nut, 2 BA ... ..						8	MR	C.	
28M/12928	A27/EP	Nut, 1/4" BSF ... ..						2	MR	C.	
1178	12 W 4207	Shim, lower ... ..						2	MR	C.	
1177	12 W 4205	Shim, upper ... ..						1	MR	C.	
28W/12296	SP.15/C	Washer ... ..						8	MR	C.	
28W/12253	SP.13/E	Washer ... ..						4	MR	C.	
	12-3W 183	<b>PANEL</b> , detachable, Port ... ..						1	—		BB.2
	12-3W 184	<b>PANEL</b> , detachable, Starboard ... ..						1	—		BB.2
		Attaching parts for 12-3W-183 and 12-3W-184, Panels :-									
28D/8300	AS.1242/1B	Bolt, 4 BA ... ..						22	—	C.	
28D/8306	AS.1242/1C	Bolt, 2 BA ... ..						3	—	C.	
10338	12 W 5395A/2	<b>SHROUD</b> , inner flap, Port (Mod. Ven. 694) ...						1	MR	B.	BB.1
10339	12 W 5396A/2	<b>SHROUD</b> , inner flap, Starboard (Mod. Ven. 964) ...						1	MR	BB.1	B.
6582	12-3S 933	<b>BRACKET</b> , mounting for pipe clip, Port ...						1	—	C.	
7913	12 W 4719ND	<b>FAIRLEAD</b> , for elevator trim tab cable on shroud rib No. 1, Port (1/4" thick, LFS.23)						1	—	C.	
7914	12 W 4721ND	<b>FAIRLEAD</b> , for elevator trim tab cable on shroud rib No. 1, Port (1/4" thick, LFS.23)						1	—	C.	
		Attaching parts for 12-3S 933, 12 W 4719ND and 12 W 4721ND, Bracket and Fairleads :									
28D/12623	A25/5B	Bolt, 4 BA ... ..						2	—	C.	
28M/10287	AGS.2001/B/1	Nut, 4 BA ... ..						2	—	C.	
28W/12305	SP.13/B	Washer ... ..						2	—	C.	
10334	12 W 131A/3	<b>SUPPORT</b> , for rear cone, Port ... ..						1	MR	C.	BB.1
10335	12 W 132A/2	<b>SUPPORT</b> , for rear cone, Starboard ... ..						1	MR	C.	BB.1
6658	12-2M 221	<b>BRACKET</b> , front attachment for fire extinguisher on cone support, L.H. ... ..						1	—	C.	
6659	12-2M 222	<b>BRACKET</b> , front attachment for fire extinguisher on cone support, R.H. ... ..						1	—	C.	
		Attaching parts for 12-2M 221 and 12-2M 222, Brackets :-									
28D/12513	A25/2C	Bolt, 2 BA ... ..						2	—	C.	
28M/10288	AGS.2001/C/1	Nut, 2 BA ... ..						2	—	C.	
28W/12252	SP.13/C	Washer ... ..						2	—	C.	
9061	12 W 5769	<b>PLATE</b> , rib attachment, bottom, Port ... (Mod. Ven. 694)						1	MR	C.	
9062	12 W 5770	<b>PLATE</b> , rib attachment, bottom, Starboard ... (Mod 694)						1	MR	C.	
		Attaching parts for 12 W 5769 and 12 W 5770, Plates :-									
28D/8307	AS.1242/2C	Bolt, 2 BA ... ..						5	—	C.	
28M/12929	A27/CP	Nut, 2 BA ... ..						5	—	C.	
28W/12252	SP.13/C	Washer ... ..						5	—	C.	

AEROFOILS

WING

Ref. No.	Part No.	Nomenclature						No Off	M.R.	Cl. of St.	Plate No.
		1	2	3	4	5	6				
2195	12 W 153	<b>PLATE</b> , rib attachment, top ... ..						1	—	C.	BB.2
		Attaching parts for 12 W 131A/3 and 12 W 12A/2, Supports, to main rib :—									
28D/15712	A59/3J	Bolt, $\frac{3}{8}$ " BSF	...	...	...	...	...	2	MR	C.	
28M/13123	A27/JS	Nut, $\frac{3}{8}$ " BSF	...	...	...	...	...	2	MR	C.	
28P/12462	SP.9/C8	Pin, split	...	...	...	...	...	2	MR	C.	
28W/12255	SP.13/J	Washer	...	...	...	...	...	2	MR	C.	
11410	12-3W 219/2	<b>SHROUD</b> , outer flap, Port (Mod. Ven. 753) ...						1	MR	B.	BB.2
11411	12-3W 220/2	<b>SHROUD</b> , outer flap, Starboard (Mod. Ven. 753) ...						1	MR	B	BB.2
	12-3W 243A/ND	<b>RIB</b> , No. 3, complete, Port ... ..						1	—		BB.2
	12-3W 244A/ND	<b>RIB</b> , No. 3 complete, Starboard ... ..						1	—		BB.2
10126	12-20WF 525ND	<b>STRIP</b> , rubber, $\frac{1}{8}$ " x $\frac{3}{16}$ " thick x 31"0 long Neoprene (Mod. Ven. 655)						1	—	C.	
7834	12 W 2181ND	<b>SKIN</b> , bottom, aft of undercarriage diaphragm, Port						1	MR	C.	BB.18
7835	12 W 2182ND	<b>SKIN</b> , bottom, aft of undercarriage diaphragm, Starboard						1	MR	C.	BB.18
	12 W 5575ND	<b>SKIN</b> , bottom, front and outboard of undercarriage diaphragm to rib No. 7, Port						1	MR		BB.18
	12 W 5576ND	<b>SKIN</b> , bottom, front and outboard of undercarriage diaphragm to rib No. 7, Starboard						1	MR		BB.18
	12 W 2187ND	<b>SKIN</b> , bottom, front outboard, Port ... ..						1	MR		BB.18
	12 W 2188ND	<b>SKIN</b> , bottom, front outboard, Starboard ... ..						1	MR		BB.18
	12 W 2887ND	<b>SKIN</b> , bottom, front, under air duct, Port ... ..						1	MR		BB.18
	12 W 2888ND	<b>SKIN</b> , bottom, front, under air duct, Starboard ... ..						1	MR		BB.18
	12 W 2185ND	<b>SKIN</b> , bottom, rear outboard, Port ... ..						1	MR		BB.18
	12 W 2186ND	<b>SKIN</b> , bottom, rear outboard, Starboard ... ..						1	MR		BB.18
	12 W 2197ND	<b>SKIN</b> , top, between ribs No. 1 and 2, Port ... ..						1	MR		BB.18
	12 W 2198ND	<b>SKIN</b> , top, between ribs No. 1 and 2, Starboard ... ..						1	MR		BB.18
	12 W 2199ND	<b>SKIN</b> , top, between ribs No. 2 and 6, aft of main spar, Port						1	MR		BB.18
	12 W 2200ND	<b>SKIN</b> , top, between ribs No. 2 and 6, aft of main spar, Starboard						1	MR		BB.18
	12 W 5423ND	<b>SKIN</b> , top, outboard of rib No. 6 to wing tip, aft of main spar, Port						1	MR		BB.18
	12 W 5424ND	<b>SKIN</b> top, outboard of rib No. 6 to wing tip, aft of main spar, Starboard						1	MR		BB.18
	12 W 3801ND	<b>SKIN</b> , trailing edge, at wing tip, outboard of aileron, bottom, Port						1	MR		BB.18
	12 W 3802ND	<b>SKIN</b> , trailing edge, at wing tip, outboard of aileron, bottom, Starboard						1	MR		BB.18
	12 W 3551ND	<b>SKIN</b> , trailing edge, at wing tip, outboard of aileron top, Port						1	MR		BB.18
	12 W 3552ND	<b>SKIN</b> , trailing edge, at wing tip, outboard of aileron, top, Starboard						1	MR		BB.10
2819	12-20W 1575A/ND	<b>SLAT</b> , wing tip, complete leading edge, Port ...						1	—	C.	
2820	12-20W 1576A/ND	<b>SLAT</b> , wing tip complete leading edge, Starboard ...						1	—	C.	
		Attaching parts for 12-20W 1575A/ND and 12-20W 1576A/ND, Slats :—									
28D/14597	AS.1244/20C	Bolt, 2 BA	...	...	...	...	...	2	—	C.	
28D/14598	AS.1244/32C	Bolt, 2 BA	...	...	...	...	...	2	—	C.	
2543	12-20W 1407	Nipple...	...	...	...	...	...	2	—	C.	
5729	12-20W 1625	Nipple...	...	...	...	...	...	2	—	C.	
2928	12-20W 1557ND	Shim (Attewell—LB2— $\frac{1}{8}$ " thick) ... ..						QR	—	C.	

WING

Ref. No.	Part No.	Nomenclature						No. Off	M.R.	Cl. of St.	Plate No.
		1	2	3	4	5	6				
4727	T.548 12 CF 965	<b>SOCKET</b> , Carr ... ..						QR	MR		
		<b>SPIGOT</b> , Servodyne, attachment ... ..						1	—	C.	BB.14
		Attaching parts for 12 CF 965, Spigot :—									
28M/13122	A27/GS	Nut, $\frac{5}{16}$ " BSF ... ..						1	—	C.	
28P/12462	SP.9/C8	Pin, split ... ..						1	—	C.	
7191	12 CF 981	Shim ... ..						1	—	C.	
28W/12254	SP.13/G	Washer ... ..						1	—	C.	
	12 W 4083ND	<b>SPINDLE</b> , for bomb release lever, at nose rib No. 6, $\frac{5}{16}$ " o/d $\times$ 17 SWG $\times$ 8-3" long, T.35 (Make from Ref. No. 30A/1939)						1	MR		BB.8
307	12 M 117	<b>SPRING</b> , at drop tank release ... ..						1	—	C.	BB.8
328	12 W 3815	<b>SPRING</b> , bomb/drop tank release, at nose rib No. 6						1	—	C.	BB.8
306	12 M 115	<b>SPRING</b> , drop tank jettison cable balance, and tension rod						3	—	C.	BB.8
	12 W 1941	<b>STIFFENER</b> , aileron shroud, outboard of outer hinge						1	MR		
5733	12 W 305A	<b>STIFFENER</b> , front, at wing tip, Port ... ..						1	MR	C.	BB.8
	12 W 306A	<b>STIFFENER</b> , front, at wing tip, Starboard ... ..						1	MR		BB.8
	12 W 5695A	<b>STIFFENER</b> , rear, at wing tip, Port (Mod. Ven. 525)						1	MR		
	12 W 5696A	<b>STIFFENER</b> , rear, at wing tip, Starboard (Mod. Ven. 525)						1	MR		
	12 W 2243ND	<b>STRAP</b> , butt, in bottom skin, at rib No. 7, Starboard						1	MR		
	12 W 5571ND	<b>STRAP</b> , butt, in bottom skin, at rib No. 5, Port ...						1	MR		
	12 W 5572ND	<b>STRAP</b> , butt, in bottom skin, at rib No. 5, Starboard						1	MR		
	12 W 2403ND	<b>STRAP</b> , butt, in top skin, at rib No. 2, Port ...						1	MR		
	12 W 2404ND	<b>STRAP</b> , butt, in top skin, at rib No. 2, Starboard						1	MR		
	12 W 2195ND	<b>STRAP</b> , butt, in top skin, at rib No. 3, forward of undercarriage diaphragm, rear of main spar, L.H.						1	MR		
	12 W 2196ND	<b>STRAP</b> , butt, in top skin, at rib No. 3, forward of undercarriage diaphragm, rear of main spar, R.H.						1	MR		
	J.666	<b>STRINGER</b> , J section ... ..						QR	MR		
	J.715	<b>STRINGER</b> , L section ... ..						QR	MR		
	J.716	<b>STRINGER</b> , L section ... ..						QR	MR		
	J.638	<b>STRINGER</b> , T section ... ..						QR	MR		
	J.718	<b>STRINGER</b> , U section ... ..						QR	MR		
6201	J.626	<b>STRINGER</b> , Z section ... ..						QR	MR	C.	
	12 W 2193ND	<b>STRIP</b> , reinforcing, in top skin, at wheel well, Port						1	MR		
	12 W 2194ND	<b>STRIP</b> , reinforcing, in top skin, at wheel well, Starboard						1	MR		
4723	12 CF 969ND	<b>STRIP</b> , rubbing, for aileron sprocket chain at false spar, bottom						1	—	C.	BB.13
4722	12 CF 967ND	<b>STRIP</b> , rubbing, for aileron sprocket chain at false spar, top						1	—	C.	BB.13
7189	12 CF 1001ND	<b>STRIP</b> , rubbing, teleflex cable at false spar, top ...						1	—	C.	
	12 W 5487ND	<b>STRIP</b> , sealing, tank screen at rib No. 1 ... .. (Make from .5" $\times$ 1.0" rubber, " Sorbo Grade D.R.M.)						QR	—		
	12 W 5241ND	<b>STRIP</b> , sealing, at No. 1 tank door landing ... .. (Make from .5" $\times$ .5" rubber " Sorbo " Grade D.R.M.)						QR	—		
	12 W 5243ND	<b>STRIP</b> , sealing, at structure round No. 1 tank bay screens Make from .5" $\times$ 1.0" rubber "Sorbo" Grade D.R.M.)						QR	—		
	12 W 5513ND	<b>STRIP</b> , sealing, at structure, round No. 1 tank bay screens (Make from .5" $\times$ 1.0" rubber "Sorbo" Grade D.R.M.)						QR	—		

AEROFOILS

WING

Ref. No.	Part No.	Nomenclature						No Off	M.R.	Cl. of St.	Plate No.
		1	2	3	4	5	6				
	12 W 5255ND	<b>STRIP</b> , sealing, at corner panel, rib No. 1 and main spar (Make from .5" x 1.0" rubber "Sorbo" Grade D.R.M.)						QR	—		
	12 W 5723A	<b>SUPPORT</b> , drop tank pick-up, Port (Mod. Ven. 525)						1	MR		
	12 W 5724A	<b>SUPPORT</b> , drop tank, pick-up, Starboard (Mod. Ven. 525)						1	MR		
338	12 W 1859A	<b>BLOCK</b> , housing, manual release ... ..						1	—	C.	BB.8
	12 W 1851	<b>LEVER</b> ... ..						1	MR		BB.8
28P/812	SP4Y/A2	<b>PIN</b> , shackle... ..						1	MR	C.	
28P/816	SP4Y/A6	<b>PIN</b> , shackle... ..						1	MR	C.	
28P/12462	SP.9/C8	<b>PIN</b> , split ... ..						2	MR	C.	
	12 W 1855	<b>PLUNGER</b> ... ..						1	MR		BB.8
	Vickers A.1832/71	<b>SLEEVE</b> , insulating ... ..						1	MR		
1894	12 W 4551	<b>SPRING</b> ... ..						1	—	C.	BB.8
28W/12306	SP.15/B	<b>WASHER</b> ... ..						4	—	C.	
28D/12811	A25/16B	<b>BOLT</b> , 4 BA, for securing housing block ... ..						2	—	C.	
5D/1740	Vickers A.5313	<b>HOUSING</b> , and feed switch ... ..						1	—	A.	
1472	12 W 4239	<b>PIN</b> ... ..						1	—	C.	BB.8
28W/12306	SP.15/B	<b>WASHER</b> ... ..						2	—	C.	
6697	12 W 4287	<b>SUPPORT</b> , rear, for drop tank, port ... ..						1	MR	C.	BB.18
	12 W 4288	<b>SUPPORT</b> , rear, for drop tank, Starboard ... ..						1	MR		BB.18
	12 W 3875ND	<b>TAG</b> , for elastic cord on turbo-starter, cartridge stowage in port wing ( $\frac{1}{32}$ " thick, upholstery leather)						4	—		
284	12 W 2763	<b>TIE-ROD</b> , in leading edge between ribs No. 2 and 3						1	—	C.	
283	12 W 2761	<b>TIE-ROD</b> , in leading edge at tank arch No. 3 ...						1	—	C.	
282	12 W 2759	<b>TIE-ROD</b> , in leading edge between ribs No. 3 and 4						1	—	C.	
281	12 W 2757	<b>TIE-ROD</b> , in leading edge at tank arch No. 4 ...						1	—	C.	
280	12 W 2755	<b>TIE-ROD</b> , in leading edge between ribs No. 4 and 5						1	—	C.	
286	12 W 3019	<b>TIE-ROD</b> , in tank arch No. 6, front ... ..						1	—	C.	
279	12 W 2753	<b>TIE-ROD</b> , in leading edge at tank arch No. 8 ...						1	—	C.	
278	12 W 2751	<b>TIE-ROD</b> , in leading edge at tank arch No. 9 ...						1	—	C.	
277	12 W 2749	<b>TIE-ROD</b> , in leading edge at tank arch No. 10 ...						1	—	C.	
285	12 W 2889	<b>TIE-ROD</b> , in tank arch No. 1B ... ..						1	—	C.	BB.1
287	12 W 3021	<b>TIE-ROD</b> , in tank arch No. 6, rear ... ..						1	—	C.	
6A/2133	132FL-SMITHS	<b>TRANSMITTER</b> , for flap position indicator, in Starboard wing						1	—	A.	BB.10
28D/12513	A25/2C	Attaching parts for A.M. Ref. No. 6A/2133, Transmitter :—									
28M/10288	AGS.2001/C/1	Bolt, 2 BA ... ..						3	—	C.	
28W/12296	SP.15/C	Nut, 2 BA ... ..						1	—	C.	
		Washer ... ..						1	—	C.	
202	12 W 211A	<b>TRUNNION</b> , for dive brake flap jack ... ..						1	—	C.	BB.11
201	12 W 209	<b>BUSH</b> ... ..						2	—	C.	BB.11
		Attaching parts for 12 W 211A, Trunnion :—									
203	12 W 219	Bolt ... ..						1	—	C.	BB.11
28N/9796	SP/21	Nipple, grease ... ..						1	—	C.	
26FC/393	D.001660A	<b>TRUNNION</b> , for flap jack ... ..						1	—	C.	
		Attaching parts for D.001660A, Trunnion :—									
28M/13122	A.27/GS	Nut, $\frac{1}{8}$ " BSF ... ..						2	—	C.	
28P/12462	SP.9/C8	Pin, split ... ..						2	—	C.	
28W/12254	SP.13/G	Washer ... ..						2	—	C.	

WING

Ref. No.	Part No.	Nomenclature						No. Off	M.R.	Cl. of St.	Plate No.
		1	2	3	4	5	6				
	12 W 4517A	<b>TUBE</b> , guide, forward, at rib No. 2, for fuel pipe, Port (Pre Mod. Ven. 889)						1	MR		BB.12
	12 W 4518A	<b>TUBE</b> , guide, forward, at rib No. 2, for fuel pipe, Starboard (Pre Mod. Ven. 889)						1	MR		BB.12
	12 W 5871A	<b>TUBE</b> , guide, forward, at rib No. 2 for fuel pipe, Port (Mod. Ven. 889)						1	MR		
	12 W 5872A	<b>TUBE</b> , guide, forward, at rib No. 2 for fuel pipe, Starboard (Mod. Ven. 889)						1	MR		
	12 W 4219A	<b>TUBE</b> , guide, rear, at rib No. 2, for fuel pipe, Port						1	MR		BB.12
	12 W 4220A	<b>TUBE</b> , guide, rear, at rib No. 2, for fuel pipe, Starboard						1	MR		BB.12
11770	12 WF 275A/ND	<b>TUBE</b> , torque, flap interconnecting, Port ... ..						1	MR	B.	BB.10
11771	12 WF 376A/ND	<b>TUBE</b> , torque, flap interconnecting, Starboard ... ..						1	MR	B.	BB.10
27S/160	Skefko TTS.10½	<b>BEARING</b> , ball-race ... ..						2	MR	B.	
	12 WF 35	<b>BRACKET</b> , support, inboard ... ..						1	MR		BB.10
3953	12 WF 37	<b>BRACKET</b> , support, outboard ... ..						1	MR	C.	BB.10
	12 WF 29	<b>LEVER</b> , torque, outboard Port and inboard Starboard						1	MR		BB.10
	12 WF 30	<b>LEVER</b> , torque, outboard Starboard and inboard Port						1	MR		BB.10
		Attaching parts for 12 W 29 and 12 WF 30, Levers :—									
28D/9296	AS.1242/15E	Bolt, ¼" BSF ... ..						6	MR	C.	
28M/10330	AGS.2002/E/1	Nut, ¼" BSF ... ..						6	MR	C.	
28W/12496	SP.15/E	Washer ... ..						6	MR	C.	
	12 WF 31	<b>TUBE</b> , torque ... ..						1	MR		BB.10
		Attaching parts for 12 W 375A/ND and 12 WF 276A/ND, Tubes :—						1	MR		BB.10
28D/12532	A25/4C	Bolt, 2 BA inside boom ... ..						4	MR	C.	
28D/8309	AS.1242/4C	Bolt, 2 BA outside boom ... ..						4	MR	C.	
28M/10288	AGS.2001/C/1	Nut, 2 BA ... ..						8	MR	C.	
	12 W 95ND	Shim, for bolts inside boom ... ..						2	MR		
	12 WF 117ND	Shim, for bolts inside boom ... ..						2	MR		
28W/12296	SP.15/C	Washer ... ..						8	MR	C.	
6B/1993	+	<b>UNIT</b> , detector, type A, for G.4F compass in Starboard wing						1	—	A.	
		Attaching parts for 6B/1993, Unit :—									
28S/2424	A44/C24	Screw, 2 BA ... ..						3	—	C.	
11A/3669	A.1832	<b>UNIT</b> , electric-magnetic release No. 1 Vickers Armstrong, less housing						1	—	A.	
		Attaching parts for A 1832, Unit :—									
8104	AVIATION DEVELOPMENTS 5298/8/17	Pin, quick release (Mod. Ven. 525) ... ..						1	—	C.	
27V/4118	TEDDINGTON FKG/A/30	<b>VALVE</b> , gate, fuel cut off at rib No. 1 (Alternative to Saunders valve Part Nos. HG/100/H10 and 810/BA01) (When Mod. Ven. 608 incorporated quantity off 1)						2	—	A.	BB.11
27F/2270	SAUNDERS	<b>VALVE</b> , gate, fuel cut off at rib No. 1 (Alternative to Teddington Valve Part No. FKG/A/30) (When Mod. Ven. 608 incorporated quantity off 1)						2	—	A.	BB.11

WING

Ref. No.	Part No.	Nomenclature						No. Off	M.R.	Cl. of St.	Plate No.
		1	2	3	4	5	6				
		Attaching parts for FKG/A/30, HG/100/H10 and 810/BA01 Valves :—									
28D/12532	A25/4C	Bolt, 2 BA (for use with HG/100/H10 Valve) ...	...	...	...	...	2	—	C.		
28D/12534	A25/9C	Bolt, 2 BA ...	...	...	...	...	2	—	C.		
28D/12516	A25/11C	Bolt, 2 BA (for use with FKG/A/30 Valve) ...	...	...	...	...	2	—	C.		
28M/10288	AGS.2001/C/1	Nut, 2 BA ...	...	...	...	...	4	—	C.		
28W/12252	SP.13/C	Washer ...	...	...	...	...	4	—	C.		
	12 P 515ND	Washer, packing, -5" o/d x -11" thick, spec. DTD.423	...	...	...	...	2	—			
	12 W 1655A/2	<b>WALL</b> , wheel well, front, part (Mod. Ven. 616) ...	...	...	...	...	1	MR		BB.6	
	12 W 1656A/2	<b>WALL</b> , wheel well, front, starboard (Mod. Ven. 616) ...	...	...	...	...	1	MR		BB.6	
10088	12 W 5721A/ND	<b>PLATE</b> , cover, centre, port (Mod. Ven. 616) ...	...	...	...	...	1	—	C.		
10089	12 W 5722A/ND	<b>PLATE</b> , cover, centre, starboard (Mod. Ven. 616) ...	...	...	...	...	1	—	C.		
		Attaching parts for 12 W 5721A/ND and 12 W 5722A/ND Plates									
28D/12101	AS.1242/3G	Bolt, $\frac{5}{16}$ " BSF ...	...	...	...	...	10	—	C.		
10990	12 W 5717A/ND	<b>PLATE</b> , cover, inboard, port (Mod. Ven. 616) ...	...	...	...	...	1	—	C.		
10091	12 W 5718A/ND	<b>PLATE</b> , cover, inboard, starboard (Mod. Ven. 616) ...	...	...	...	...	1	—	C.		
		Attaching parts for 12 W 5717A/ND and 12 W 5718A/ND, Plates									
28D/12815	A25/3G	Bolt, $\frac{5}{16}$ " BSF ...	...	...	...	...	16	—	C.		
28D/12102	AS.1242/3G	Bolt, $\frac{5}{16}$ " BSF ...	...	...	...	...	2	—	C.		
28W/12324	SP.15/G	Washer ...	...	...	...	...	16	—	C.		
827	12 W 1683ND	<b>PLATE</b> , cover, outboard ...	...	...	...	...	1	—	C.	BB.6	
		Attaching parts for 12 W 1383ND Plate :—									
28D/12519	A25/3E	Bolt, $\frac{3}{8}$ " BSF ...	...	...	...	...	6	—	C.		
28D/12520	A25/4E	Bolt, $\frac{3}{8}$ " BSF ...	...	...	...	...	1	—	C.		
28D/12542	A25/5E	Bolt, $\frac{3}{8}$ " BSF ...	...	...	...	...	1	—	C.		
28W/12496	SP.15/E	Washer ...	...	...	...	...	8	—	C.		
		Attaching parts for 12 W 1655A/2 and 12 W 1656A/2, Walls :—									
28D/9755	AS.1242/7G	Bolt, $\frac{5}{16}$ " BSF ...	...	...	...	...	5	—	C.		
28D/12818	A25/9G	Bolt, $\frac{5}{16}$ " BSF ...	...	...	...	...	2	—	C.		
28D/12820	A25/13G	Bolt, $\frac{5}{16}$ " BSF ...	...	...	...	...	8	—	C.		
28M/13375	A27/GP	Nut, $\frac{5}{16}$ " BSF ...	...	...	...	...	15	—	C.		
28W/12254	SP.13/G	Washer ...	...	...	...	...	16	—	C.		
28W/12347	SP.16/G	Washer ...	...	...	...	...	7	—	C.		
	12 W 1691A/3	<b>WALL</b> , wheel well, rear, Port (Mod. Ven. 616) ...	...	...	...	...	1	MR		BB.6	
	12 W 1692A/3	<b>WALL</b> , wheel well, rear, Starboard (Mod. Ven. 716) ...	...	...	...	...	1	MR		BB.6	
10094	12 W 5755ND	<b>PLATE</b> , cover, centre (Mod. Ven. 616) ...	...	...	...	...	1	—	C.		
		Attaching parts for 12 W 5755ND, Plate :—									
28D/12815	A25/3G	Bolt, $\frac{5}{16}$ " BSF ...	...	...	...	...	8	—	C.		
28W/12324	SP.15/G	Washer ...	...	...	...	...	8	—	C.		
10092	12 W 5713A/ND	<b>PLATE</b> , cover, inboard, Port ...	...	...	...	...	1	—	C.		
10093	12 W 5714A/ND	<b>PLATE</b> , cover, inboard, Starboard ...	...	...	...	...	1	—	C.		
		Attaching parts for 12 W 5713A/ND and 12 W 5714A/ND Plates :—									
28D/12815	A25/3G	Bolt, $\frac{5}{16}$ " BSF ...	...	...	...	...	6	—	C.		
28D/12102	AS.1242/3G	Bolt, $\frac{5}{16}$ " BSF ...	...	...	...	...	2	—	C.		
28W/12324	SP.15/G	Washer ...	...	...	...	...	6	—	C.		
300	12 W 1713ND	<b>PLATE</b> , cover, outboard ...	...	...	...	...	1	—	C.		
		Attaching parts for 12 W 1713ND, Plate :—									
28D/12815	A25/3G	Bolt, $\frac{5}{16}$ " BSF ...	...	...	...	...	8	—	C.		
28W/12324	SP.15/G	Washer ...	...	...	...	...	8	—	C.		
		Attaching parts for 12 W 1691A/3 and 12 W 1692A/3, Walls :—									
28D/12102	AS.1242/3G	Bolt, $\frac{5}{16}$ " BSF ...	...	...	...	...	3	—	C.		
28D/10742	AS.1242/5G	Bolt, $\frac{5}{16}$ " BSF ...	...	...	...	...	1	—	C.		
28D/10743	AS.1242/6G	Bolt, $\frac{5}{16}$ " BSF ...	...	...	...	...	2	—	C.		
28D/13582	A25/11G	Bolt, $\frac{5}{16}$ " BSF ...	...	...	...	...	6	—	C.		
28M/13375	A27/GP	Nut, $\frac{5}{16}$ " BSF ...	...	...	...	...	12	—	C.		
28W/12254	SP.13/G	Washer ...	...	...	...	...	11	—	C.		
28W/12347	SP.16/G	Washer ...	...	...	...	...	7	—	C.		

WING

Ref. No.	Part No.	Nomenclature						No. Off	M.R.	Cl. of St.	Plate No.
		1	2	3	4	5	6				
28W/6562	AGS.568/A	WASHER, at clip on dove brake flap jack ... ..						1	—	C.	
28F/12047	AGS.1186/A	WASHER, jointing, bonded, at dive brake flap jack lower end						2	—	C.	
	12 W 2275ND	WASHER, profile, at top attaching bolts rib No. 8 and tank arch to main spar						2	MR		
	12 W 2277ND	WASHER, profile, at top attaching bolts, rib No. 9 and tank arch to main spar						2	MR		
28W/12305	SP.13/B	WASHER, for carr sockets ... ..						10	MR	C.	
28F/9585	AGS.1149/2	WASHER, jointing for hydraulic pipe connections at false spar						2	—	C.	
28F/10109	AGS.1149/4	WASHER, jointing for hydraulic pipe connections at false spar						2	—	C.	

TAIL UNIT

Ref. No.	Part No.	Nomenclature						No. Off	M.R.	Cl. of St.	Plate No.
		1	2	3	4	5	6				
		<b>TAIL UNIT</b> (12-4T 1) ... ..						<b>1</b>	—		BC.1
1184	12 T 287	<b>ANGLE</b> , attachment, front, for tailplane extension tip, LH.						<b>1</b>	—	C.	BC/1
1179	12 T 288	<b>ANGLE</b> , attachment, front, for tailplane extension tip, R.H.						<b>1</b>	—	C.	BC.1
1186	12 T 225	<b>ANGLE</b> , attachment, rear, for tailplane extension tip						<b>2</b>	—	C.	BC.1
1185	12 T 285	<b>BLOCK</b> , packing, between fin and tailplane extension tip front attachment angle, L.H.						<b>1</b>	—	C.	BC.1
1180	12 T 286	<b>BLOCK</b> , packing, between fin and tailplane extension tip front attachment angle, R.H.						<b>1</b>	—	C.	BC.1
28D/13857	A25/3J	<b>BOLT</b> , $\frac{3}{8}$ " BSF, at front and rear attachment of fin/tailplane joint						<b>4</b>	—	C.	
935	12 T 205	<b>BOLT</b> , shear, at fin/tailplane front joint ... ..						<b>2</b>	—	C.	BC.1
26FC/2538	J.00460A	<b>BRACKET</b> , for ball-race bearing, at spigot on elevator, Port						<b>1</b>	—	C.	BC.1
26FC/2537	J.00459A	<b>BRACKET</b> , for ball-race bearing, at spigot on elevator, Starboard						<b>1</b>	—	C.	
		Attaching parts for J.00460A and J.00459A, Brackets :—									
28D/12636	A25/25E	Bolt, $\frac{1}{8}$ " BSF ... ..						<b>2</b>	—	C.	
28D/13582	A25/11G	Bolt, $\frac{5}{16}$ " BSF, for adjusting plate ... ..						<b>1</b>	—	C.	
28M/12930	A27/ES	Nut, $\frac{1}{4}$ " BSF ... ..						<b>2</b>	—	C.	
28M/13122	A27/GS	Nut, $\frac{5}{16}$ " BSF, for bolt through adjusting plate ... ..						<b>1</b>	—	C.	
28P/12462	SP.9/C8	Pin, split ... ..						<b>3</b>	—	C.	
26FC/8038	J.00984	<b>Plate</b> , adjusting, -0° ... ..						<b>QR</b>	—	C.	BC.1
	J.00984 Mk. 2	<b>Plate</b> , adjusting, + 12'/-12' ... ..						<b>QR</b>	—		
	J.00984 Mk. 3	<b>Plate</b> , adjusting, + 24'/-24' ... ..						<b>QR</b>	—		
	J.00984 Mk. 4	<b>Plate</b> , adjusting, + 36'/-36' ... ..						<b>QR</b>	—		
	J.00984 Mk. 5	<b>Plate</b> , adjusting, + 49'/-49' ... ..						<b>QR</b>	—		
	J.00984 Mk. 6	<b>Plate</b> , adjusting, + 61'/-61' ... ..						<b>QR</b>	—		
	J.00984 Mk. 7	<b>Plate</b> , adjusting, + 73'/-73' ... ..						<b>QR</b>	—		
	J.00984 Mk. 8	<b>Plate</b> , adjusting, + 85' /85' ... ..						<b>QR</b>	—		
28W/12253	SP.13/E	Washer ... ..						<b>4</b>	—	C.	
28W/12254	SP.13/G	Washer, for bolt through adjusting plate ... ..						<b>1</b>	—	C.	
9349	12-4TE 1A/1	<b>ELEVATOR</b> , (see separate unit) ... ..						<b>1</b>	—	A.	BC.1
		Alternative									
7688	12 TE 781A	<b>ELEVATOR</b> , (see separate unit) ... ..						<b>1</b>	—	A.	BC.1
		Attaching parts for 12-4TE 1A/1 or 12 TE 781A, Elevator :—									
26BY/4552	Skefko 400602/C-001	Bearing, ball-race, at spigot ... ..						<b>2</b>	—	B.	
28D/12537	AS.2504/20G	Bolt, $\frac{5}{16}$ " BSF at hinges ... ..						<b>2</b>	—	C.	
28M/12930	A27/ES	Nut, $\frac{1}{4}$ " BSF at spigot ... ..						<b>2</b>	—	C.	
28M/13122	A27/GS	Nut, $\frac{5}{16}$ " BSF for bolt at hinges ... ..						<b>2</b>	—	C.	
28P/12462	SP.9/C8	Pin, split ... ..						<b>4</b>	—	C.	
28W/12253	SP.13/E	Washer ... ..						<b>2</b>	—	C.	
8189	12 T 513A	<b>FAIRING</b> , at fin/tailplane joint, Port (undrilled)						<b>1</b>	—	C.	BC/1
8190	12 T 514A	<b>FAIRING</b> , at fin/tailplane joint, Starboard (undrilled)						<b>1</b>	—	C.	BC.1
		Attaching parts for 12 T 513A and 12 T 514A, Fairings :—									
28D/8306	AS.1242/1C	Bolt, 2 BA ... ..						<b>174</b>	—	C.	
26FN/1770	DHS.166/C	Washer, 2 BA ... ..						<b>174</b>	—	C.	

TAIL UNIT

Ref. No.	Part No.	Nomenclature						No. Off	M.R.	Cl. of Sc.	Plate No.
		1	2	3	4	5	6				
	12 TP 129	<b>FAIRING</b> , nose, elevator mechanism (not supplied with Tailplane 12-2 TP 1A)						1	—		BC.1
		Attaching parts for 12 TP 129, Fairing :—									
28Q/6763	AGS.2047/504	Pin, sealing ... ..						6	—	C.	
28Q/6879	AGS.2046/506	Rivet, $\frac{5}{32}$ " ... ..						6	—	C.	
†	†	<b>FAIRING</b> , rear attachment (12 TB 225) ... ..						1	—		
†	†	<b>DOOR</b> , and telebrief plug (12 TB 151A/1) ... ..						1	—		
	12 TB 159A	<b>BRACKET</b> , hinge, telebrief door ... ..						1	—		BE.1
		Attaching parts for 12 TB 159A, Bracket :—									
28D/12531	A25/3C	Bolt, 2 BA ... ..						4	—	C.	
28M/10288	AGS.2001/C/1	Nut, 2 BA ... ..						4	—	C.	
28P/862	SP.4/Y/D4	Pin, shouldered ... ..						4	—	C.	
	12 TB 235A	<b>CABLE</b> , check for telebrief door ... ..						1	—		BE.1
		Attaching parts for 12 TB 235A, Cable :—									
28D/12532	A25/4C	Bolt, 2 BA ... ..						1	—	C.	
28D/12531	A25/3C	Bolt, 2 BA ... ..						3	—	C.	
28M/10288	AGS.2001/C/1	Nut, 2 BA ... ..						4	—	C.	
10HA/9326	Type 3570	<b>CONNECTOR</b> , telebrief plug ... ..						1	—	A.	
2909	12 TB 211A/ND	<b>DOOR</b> , less telebrief plug ... ..						1	—	C.	
	12 TB 239A/ND	<b>FAIRING</b> , rear, port ... ..						1	—		
9369	12 TB 223A	<b>FAIRING</b> , bullet and rear fairing ... ..						1	MR	A.	BE.1
8841	12-20TB 137A	<b>FAIRING</b> , rear bullet ... ..						1	MR	A.	BE.1
2565	12-2 TB 105	<b>FAIRING</b> , tail lamp ... ..						1	—	B.	BE.1
		Attaching parts for 13-2TB 105, Fairing :—									
28D/8300	AS.1242/1B	Bolt, 4 BA ... ..						4	—	C.	
5CX/500	†	<b>GLASS</b> , lamp, clear ... ..						1	—	C.	
5CX/498	†	<b>LAMP</b> , navigation, tail ... ..						1	—	A.	
5CX/501	†	<b>SOCKET</b> , lamp ... ..						1	—	B.	
		Attaching parts for 5CX/501, Socket :—									
28D/8301	AS.1242/2B	Bolt, 4 BA ... ..						2	—	C.	
		Attaching parts for 12-20TB 1374, Fairing :—									
28D/8306	AS.1242/1C	Bolt, 2 BA ... ..						14	—	C.	
	12 TB 221A	<b>FAIRING</b> , rear, Port ... ..						1	—		BE.1
5099	12-2TB 99ND	<b>DOOR</b> , access ... ..						2	MR	C.	BE.1
		Attaching parts for 12-2TB 99ND, Door :—									
28D/8300	AS.1242/1B	Bolt, 4 BA ... ..						16	—	C.	
		Attaching parts for 12 TB 221A, Fairing :—									
28D/8306	AS.1242/1C	Bolt, 2 BA ... ..						12	—	C.	

AEROFOILS

ELEVATOR

Ref. No.	Part No.	Nomenclature						No Off	M.R.	Cl. of St.	Plate No.
		1	2	3	4	5	6				
9349	12-4TE 1A/1	<b>ELEVATOR</b> ... ..						1	—	A.	BC.1
		Alternative									
7688	12 TE 781A	<b>ELEVATOR</b> ... ..						1	—	A.	BD.1
	12 TE 125	<b>BRACKET</b> , for R.H. hinge ... ..						1	—		BD.1
		Attaching parts for 12 TE 125, Bracket :—									
28D/12542	A25/5E	Bolt, 1/4" BSF ... ..						3	—	C.	
28D/12519	A25/3E	Bolt, 1/4" BSF ... ..						3	—	C.	
28M/10290	AGS.2001/E/1	Nut, 1/4" BSF ... ..						6	—	C.	
28W/12352	SP.10/E	Washer ... ..						6	—	C.	
	12 TE 195A	<b>BRACKET</b> , mounting spring housing, R.H. tab ... ..						1	—		BD.2
		(Alternative to Part No. 12 TE 375A)									
		Attaching parts for 12 TE 195A, Bracket :—									
28D/12513	A25/2C	Bolt, 2 BA ... ..						14	—	C.	
28L/13124	A27/CT	Locknut, 2 BA ... ..						6	—	C.	
28M/12929	A27/CP	Nut, 2 BA ... ..						8	—	C.	
28W/14319	SP.11/C	Washer ... ..						14	—	C.	
	12 TE 375A	<b>BRACKET</b> , mounting spring housing, R.H. tab ... ..						1	—		BD.2
		(Alternative to Part No. 12 TE 195A)									
		Attaching parts for 12 TE 375A, Bracket :—									
28D/12531	A25/3C	Bolt, 2 BA ... ..						12	—	C.	
28L/13124	A.27/CT	Locknut, 2 BA ... ..						6	—	C.	
28M/12929	A27/CP	Nut, 2 BA ... ..						6	—	C.	
28W/14319	SP.11/C	Washer ... ..						12	—	C.	
	12 TE 289A	<b>BRACKET</b> , R.H. tab control lever pivot ... ..						1	—		BD.1
4644	12-20TE 313A	<b>DOOR</b> , access ... ..						2	—	C.	BD.1
		Attaching parts for 12-20TE 313A, Door :—									
28D/8306	AS.1242/1C	Bolt, 2 BA ... ..						9	—	C.	
	J.001645	<b>EDGE</b> , trailing, L.H. ... ..						1	MR		BD.1
	12 TE 395	<b>EDGE</b> , trailing, R.H. ... ..						1	MR		BD.1
1315	12 TE 437	<b>EYE-BOLT</b> , at actuating lever, R.H. tab ... ..						1	—	C.	BD.2
		Attaching parts for 12 TE 437, Eye-bolt :—									
1286	12 TE 179	Bolt, special ... ..						1	—	C.	BD.2
28L/13326	A.27/GT	Locknut, 1/8" BSF ... ..						1	—	C.	
28M/12930	A27/ES	Nut, 1/8" BSF ... ..						1	—	C.	
28W/12354	SP.10/G	Washer ... ..						1	—	C.	
26FC/3161	J.00793	<b>FAIRING</b> , at tab operating rod ... ..						1	MR	C.	BD.1
	12-20TE 181	<b>FAIRING</b> , rear ... ..						1	—		BD.2
		Attaching parts for 12-20TE 181, Fairing :—									
28D/8306	AS.1242/1C	Bolt, 2 BA ... ..						8	—	C.	
26BY/3108	DHS.96	Washer, cup ... ..						8	—	C.	
8155	12 TE 823A	<b>FAIRING</b> , balance arm ... ..						1	MR	C.	BD.1
		Attaching parts for 12 TE 823A, Fairing :—									
28D/12529	A25/4B	Bolt, 4 BA ... ..						1	—	C.	
28D/11654	AS.1246/1C	Bolt, 2 BA ... ..						3	—	C.	
28D/11255	AS.1246/2C	Bolt, 2 BA ... ..						1	—	C.	
28L/13140	A.27/BT	Locknut, 4 BA ... ..						1	—	C.	
28W/12245	SP.10/C	Washer ... ..						4	—	C.	

Ref. No.	Part No.	Nomenclature						No. Off	M.R.	Cl. of St.	Plate No.
		1	2	3	4	5	6				
26FC/3162	J.00783	<b>FITTING</b> , at L.H. end rib for torque tube ...						1	MR	C.	BD.1
28D/12531	A25/3C	Attaching parts for J.00783, Fitting :—									
26FC/400	DHS.94/8/195	Bolt, 2 BA ...						3	MR	C.	
		Pin ...						3	MR	C.	
5114	12 TE 133	<b>FORK-END</b> , at spring housing, R.H. tab ...						1	MR	C.	BD.2
7809	12 TE 413A	<b>HINGE</b> , L.H. ...						1	MR	C.	BD.2
28D/13582	A25/11G	<b>BOLT</b> , $\frac{5}{16}$ " BSF ...						1	—	C.	
1283	12 TE 415	<b>BRACKET</b> ...						1	—	C.	BD.2
26FC/2440	J.00171A	<b>LINK</b> , hinge ...						1	—	C.	BD.2
28M/13122	A27/GS	<b>NUT</b> , $\frac{5}{16}$ " BSF ...						1	—	C.	
28P/5032	AGS.784/3	<b>PIN</b> , split ...						1	—	C.	
26BY/503	J.98484	<b>WASHER</b> , felt ...						2	—	C.	BD.2
28D/12520	A25/4E	Attaching parts for 12 TE 413A, Hinge :—									
		Bolt, $\frac{1}{4}$ " BSF ...						4	—	C.	
3825	12 TE 97A	<b>HOUSING</b> , ball-race, for R.H. torque tube ...						1	MR	B.	BD.1
27S/164	Skefko T.T.S.14 $\frac{1}{2}$	<b>BEARING</b> , ball-race ...						1	—	B.	
28D/8307	AS.1242/2C	Attaching parts for 12 TE 97A, Housing :—									
28M/12929	A27/CP	Bolt, 2 BA ...						4	MR	C.	
		Nut, 2 BA ...						4	MR	C.	
3824	12 TE 101A	<b>HOUSING</b> , ball-race, for R.H. torque tube ...						1	MR	B.	BD.1
27S/164	Skefko T.T.S.14 $\frac{1}{2}$	<b>BEARING</b> , ball-race ...						1	—	B.	
28D/8307	AS.1242/2C	Attaching parts for 12 TE 101A, Housing :—									
28D/8308	AS.1242/3C	Bolt, 2 BA ...						2	MR	C.	
28M/12929	A27/CP	Bolt, 2 BA ...						3	MR	C.	
		Nut 2 BA ...						4	MR	C.	
5116	12 TE 119A/1	<b>LEVER</b> , actuating, R.H. tab ...						1	—	B.	BD.2
5117	12 TE 120A/1	<b>LEVER</b> , actuating, R.H. tab ...						1	—	B.	BD.2
27S/135	Skefko CBS.3	<b>BEARING</b> , ball-race ...						1	—	B.	
3842	12 TE 123	<b>BUSH</b> ...						1	—	C.	BD.2
1950	12 TE 503	Attaching parts for 12 TE 119A/1 and 12 TE 120A/1, Levers :—									
5110	12 TE 149	Bolt, special ...						2	—	C.	BD.2
28M/12930	A27/ES	Bolt, special ...						1	MR	C.	BD.2
28M/13122	A27/GS	Nut, $\frac{1}{4}$ " BSF ...						2	—	C.	
		Nut, $\frac{5}{16}$ " BSF ...						1	—	C.	
1316	12 TE 439	Tube, distance ...						2	—	C.	BD.2
28W/12253	SP.13/E	Washer, shim ...						1	—	C.	
28W/12254	SP.13/G	Washer ...						2	—	C.	
28W/12322	SP.16/J	Washer ...						1	—	C.	
6407	12 TE 679A	<b>LEVER</b> , connecting rod, L.H. tab ...						1	MR	C.	BD.2
6408	12 TE 681A	<b>LEVER</b> , connecting rod, R.H. tab ...						1	MR	C.	BD.2
		Attaching parts for 12 TE 679A and 12 TE 681A, Levers :—									
1286	12 TE 179	Bolt, special ...						1	—	C.	BD.2
3840	12 TE 291	Bolt, special ...						1	—	C.	BD.2
3827	12 TE 299	Bolt, special, at spring housing ...						1	—	C.	BD.2
28M/12930	A27/ES	Nut, $\frac{1}{4}$ " BSF ...						3	—	C.	
28W/12354	SP.10/G	Washer ...						1	—	C.	
28W/12352	SP.10/E	Washer ...						3	—	C.	

Ref. No.	Part No.	Nomenclature						No Off	M.R.	Cl. of St.	Plate No.
		1	2	3	4	5	6				
27S/143	12 TE 381A	<b>LEVER</b> , operating, R.H. ... ..						1	MR		BD.1
	Skefko I.132499	<b>BEARING</b> , ball-race ... ..						1	—	B.	
	DHS.94/8/210	Attaching parts for 12 TE 381A, Lever :— Pin ... ..						3	MR		
26FC/2440	J.00.171A	<b>LINK</b> , hinge, R.H. ... ..						1	—	B.	BE.2
27S/142	Skefko I.132498	<b>BEARING</b> , ball-race ... ..						1	—	B.	
		Attaching parts for J.00171A, Link :—									
5110	12 TE 149	Bolt, special ... ..						1	MR	C.	BD.2
28M/13122	A27/GS	Nut, $\frac{5}{16}$ " BSF ... ..						1	—	C.	
28P/12462	SP.9/C8	Pin, split ... ..						1	—	C.	
28W/12254	SP.13/G	Washer ... ..						1	—	C.	
28L/13326	A.27/GT	<b>LOCKNUT</b> , $\frac{5}{16}$ " BSF, at eye-bolt ... ..						1	—	C.	
	12 TE 553	<b>MOUNTING</b> , support for mass balance ... ..						2	—		BD.1
		Attaching parts for 12 TE 553, Mounting :—									
28D/12532	A25/4C	Bolt, 2 BA ... ..						12	—	C.	
28D/8308	AS.1242/3C	Bolt, 2 BA ... ..						24	—	C.	
28M/10288	AGS.2001/C/1	Nut, 2 BA ... ..						24	—	C.	
28M/12929	A27/CP	Nut, 2 BA ... ..						12	—	C.	
28W/12252	SP.13/C	Washer ... ..						36	—	C.	
26FC/3160	J.00916A	<b>PLATE</b> , cover, at L.H. hinge ... ..						2	—	C.	BD.1
		Attaching parts for J.00916A, Plate :—									
	28D/8306	Bolt, 2 BA ... ..						2	—	C.	
3843	12 TE 115	<b>PLUG-END</b> , torque tube at R.H. tab levers ... ..						1	MR	C.	BD.2
26FC/3168	J.00744A	<b>RIB</b> , end L.H. ... ..						1	MR	C.	BD.1
1284	12 TE 409A	<b>RIB</b> , end R.H. ... ..						1	MR	C.	BD.1
	12 TE 441A	<b>RIB</b> , nose, at L.H. hinge ... ..						2	MR		BD.2
	12 TE 555A	<b>RIB</b> , nose, at L.H. hinge ... ..						1	—		BD.2
	12-20 TE 335	<b>RIB</b> , hinge, R.H. ... ..						1	—		BD.1
	12-20 TE 323A	<b>RIB</b> , hinge, L.H. ... ..						1	—		BD.1
3839	12 TE 201A	<b>ROD</b> , connecting, R.H. tab ... ..						1	MR	C.	BD.2
9525	12 TE 277	<b>EYE-END</b> ... ..						1	—	C.	BD.1
28L/13326	A.27/GT	<b>LOCKNUT</b> , $\frac{5}{16}$ " BSF ... ..						1	—	C.	
		Attaching parts for 12 TE 201A, Rod :—									
	3833	Bolt, special ... ..						2	—	C.	BD.2
	28M/13121	Nut, 2 BA ... ..						2	—	C.	
	28P/12462	Pin, split ... ..						2	—	C.	
	28W/12245	Washer ... ..						2	—	C.	
882	J.777	<b>SECTION</b> , spoiler on trailing edge ... ..						QR	MR	C.	BD.1
3971	12 TE 113	<b>SLEEVE</b> , inner for R.H. torque tube ... ..						1	MR	C.	BD.1
	12 TE 669A	<b>SPAR</b> , trailing edge, tab support ... ..						1	MR		BD.3
	12 TE 193	<b>BRACKET</b> , hinge, elevator tab ... ..						3	—		BD.3
		Attaching parts for 12 TE 193, Bracket :—									
28D/12513	A25/2C	Bolt, 2 BA ... ..						2	—	C.	
26FC/2404	J.00302	<b>SPIGOT</b> , at operating lever ... ..						2	MR	C.	BD.1
		Attaching parts for J.00302, Spigot :—									
	28M/13375	Nut, $\frac{5}{16}$ " BSF ... ..						1	MR	C.	
	28W/12254	Washer ... ..						1	MR	C.	

ELEVATOR

Ref. No.	Part No.	Nomenclature						No. Off	M.R.	Cl. of St.	Plate No.
		1	2	3	4	5	6				
10458	12 TE 773A	<b>SPRING</b> , box R.H. tab ... ..						1	—	B.	BD.2
	12-20TE 163	<b>CAP</b> , for spring housing ... ..						1	—		BD.2
	12-20TE 171	<b>CLIP</b> , spring ... ..						1	—		BD.2
	12-20TE 229	<b>GUIDE</b> , plunger ... ..						1	—		BD.2
	12-20TE 185A/1	<b>HOUSING</b> , spring ... ..						1	—		BD.2
	12 TE 777	<b>PIECE</b> , distance ... ..						2	—		BD.2
	12-20TE 165	<b>PLUNGER</b> , shaft ... ..						1	—		BD.2
	12 TE 769	<b>SPRING</b> , inner ... ..						1	—		BD.2
	12-20TE 159	<b>SPRING</b> , outer ... ..						1	—		BD.2
	12-20TE 481	<b>STOP</b> , spring travel ... ..						1	—		BD.2
	12-20TE 483	<b>STOP</b> , spring travel ... ..						1	—		BD.2
	12-20TE 173	<b>WASHER</b> , shim ... ..						1	—		
	12-20TE 177	<b>WASHER</b> , shim ... ..						1	—		
	12-20TE 179	<b>WASHER</b> , shim ... ..						1	—		
		Attaching parts for 12 TE 773A, Spring Box :—									
3828	12 TE 183	Bolt, special ... ..						1	—	C.	BD.2
28M/13121	A27/CS	Nut, 2 BA ... ..						1	—	C.	
28W/12352	SP.10/E	Washer ... ..						1	—	C.	
	J.001718ND	<b>STRIP</b> , balance, at trailing edge, 24 SWG, L.72 ...						1	MR		
1294	12 TE 53A/1	<b>TAB</b> , L.H. ... ..						1	MR	C.	BD.1
26FC/4171	J.001807ND	<b>HINGE</b> ... ..						1	MR	C.	BD.1
26FC/4347	J.001829	<b>LEVER</b> , for operating rod ... ..						1	—	C.	BD.1
		Attaching parts for J.001829, Lever :—									
28D/8311	AS.1242/7C	Bolt, 2 BA ... ..						1	—	C.	
28D/8314	AS.1242/10C	Bolt, 2 BA ... ..						1	—	C.	
28M/12929	A27/CP	Nut, 2 BA ... ..						2	—	C.	
	J.00451	Plate, washer ... ..						1	—	C.	BD.1
	12 TE 233ND	<b>SECTION</b> , spoiler (make from J.777-26DV/882) <b>QR</b>						MR			BD.1
26FC/6433	J.001492A	<b>WEIGHT</b> , balance ... ..						1	MR	C.	BD.1
		Attaching parts for 12 TE 53A/1, Tab :—									
28D/8337	AS.1248/1B	Bolt, 4 BA ... ..						27	—	C.	
28D/9744	AS.1248/2B	Bolt, 4 BA ... ..						2	—	C.	
28M/10287	AGS.2001/B/1	Nut, 4 BA ... ..						29	—	C.	
28W/12305	SP.13/B	Washer ... ..						29	—	C.	
4834	12 TE 145	<b>TAB</b> , R.H. ... ..						1	—	B.	BD.1
1530	12 TE 57A/1	<b>EYE-BOLT</b> ... ..						3	—	C.	BD.2
1528	12 WA 717	<b>BUSH</b> ... ..						1	—	C.	BD.2
9526	12 TE 279A	<b>LEVER</b> , control for operating lever ...						1	—	C.	BD.2
		Attaching parts for 12 TE 279A, Lever :—									
28D/8309	AS.1242/4C	Bolt, 2 BA ... ..						1	—	C.	
28D/8313	AS.1242/9C	Bolt, 2 BA ... ..						1	—	C.	
28M/12929	A27/CP	Nut, 2 BA ... ..						2	—	C.	
	12 TE 313	<b>WEIGHT</b> , balance ... ..						1	—		BD.2
	12 TE 315	<b>WEIGHT</b> , balance ... ..						1	—		BD.2
		Attaching parts for 12 TE 145, Tab :—									
1503	12 TE 453	Pin, shackle ... ..						3	—	C.	BD.2
28P/12462	SP.9/8C	Pin, split ... ..						3	—	C.	
28W/12245	SP.10/C	Washer ... ..						3	—	C.	

Ref. No.	Part No.	Nomenclature						No. Off	M.R.	Cl. of St.	Plate No.
		1	2	3	4	5	6				
	J.00901	<b>TUBE</b> , torque, L.H., 1½" o/d × 17 SWG × 17-25" long, T.45 (Make from Ref. No. 30A/1786)						2	MR		BD.1
		Attaching parts for J.00901, Tube :—									
28D/12539	A25/16C	Bolt, 2 BA	...	...	...	...	...	2	—	C.	
28M/10328	AGS.2002/C/1	Nut, 2 BA	...	...	...	...	...	2	—	C.	
3970	12 TE 401A	<b>TUBE</b> , torque, R.H. ... ..						1	MR	C.	BD.1
		Attaching parts for 12 TE 401A, Tube :—									
	DHS.94/8/185	Pin	...	...	...	...	...	6	—		
	12 TE 565A/2	<b>WEIGHT</b> , elevator mass balance ... ..						2	—		BD.1
		Attaching parts for 12 TE 565A/2, Weight :—									
2561	12-20TE 247	Bolt, special	...	...	...	...	...	1	—	C.	BD.1
2562	12-20TE 249	Collar	...	...	...	...	...	1	—	C.	BD.1
28M/12930	A27/ES	Nut, ¼" BSF	...	...	...	...	...	1	—	C.	

FIN AND BOOM

Ref. No.	Part No.	Nomenclature						No. Off	M.R.	Cl. of St.	Plate No.
		1	2	3	4	5	6				
8829	12 T 705A/2	<b>FIN AND BOOM, Port</b> ... ..						1	—	A.	BE.1
8830	12 T 706A/2	<b>FIN AND BOOM, Starboard</b> ... ..						1	—	A.	BE.1
	12 TB 59	<b>ANGLE, boom attachment</b> ... ..						1	MR		BE.1
	12 TB 231A	<b>BOOM, tail, less fin, Port</b> ... ..						1	—		BE.1
	12 TB 232A	<b>BOOM, tail, less fin, Starboard</b> ... ..						1	—		BE.1
	12 CF 431A	<b>BRACKET, complete with lever, bottom, Port</b> ... ..						1	MR		BE.1
26FC/3238	K.00352	<b>BRACKET</b> ... ..						1	MR	C.	BE.1
26FC/3263	K.00470A	<b>LEVER, rudder</b> ... ..						1	—	B.	BE.1
27S/135	Skefko I.132629	<b>BEARING, ball-race, bottom</b> ... ..						1	—	B.	
27S/134	Skefko 400014	<b>BEARING, ball-race, centre</b> ... ..						1	—	B.	
27S/142	Skefko I.132498	<b>BEARING, ball-race, top</b> ... ..						1	—	B.	
28M/12930	A27/ES	<b>NUT, 1/4" BSF, for spindle</b> ... ..						2	—	C.	
	AS.2811/8/025	<b>PIECE, distance...</b> ... ..						1	—		
28P/12462	SP.9/C8	<b>PIN, split, for spindle nut</b> ... ..						2	—	C.	
26FC/3239	K.00364	<b>SPINDLE</b> ... ..						1	—	C.	BE.1
	K.00355A	<b>BRACKET, complete with levers, bottom, Starboard</b> ... ..						1	MR		BE.1
26FC/3238	K.00352	<b>BRACKET</b> ... ..						1	MR	C.	BE.1
26FC/3264	K.00471A	<b>LEVER, elevator</b> ... ..						1	—	B.	BE.1
27S/135	Skefko I.132629	<b>BEARING, ball-race, bottom</b> ... ..						1	—	B.	
27S/134	Skefko 400014	<b>BEARING, ball-race, centre</b> ... ..						1	—	B.	
27S/143	Skefko I.132499	<b>BEARING, ball-race, top</b> ... ..						1	—	B.	
26FC/3951	K.00455	<b>BUSH, at top ball-race bearing</b> ... ..						1	—	C.	
26FC/3263	K.00470A	<b>LEVER, rudder</b> ... ..						1	—	B.	BE.1
27S/135	Skefko I.132629	<b>BEARING, ball-race, bottom</b> ... ..						1	—	B.	
27S/134	Skefko 400014	<b>BEARING, ball-race, centre</b> ... ..						1	—	B.	
27S/142	Skefko I.132498	<b>BEARING, ball-race, top</b> ... ..						1	—	B.	
28M/12930	A27/ES	<b>NUT, 1/4" BSF for spindle</b> ... ..						2	—	C.	
28P/12462	SP.9/C8	<b>PIN, split for spindle nut</b> ... ..						2	—	C.	
26FC/3239	K.00364	<b>SPINDLE</b> ... ..						1	—	C.	BE.
	12 TB 21	<b>BRACKET, fin and tail from joint</b> ... ..						1	—		BE.1
		Attaching parts for 12 TB 21, Bracket :—									
28D/12532	A25/4C	Bolt, 2 BA ... ..						4	—	C.	
28D/12533	A25/5C	Bolt, 2 BA ... ..						2	—	C.	
28M/12929	A27/CP	Nut, 2 BA ... ..						6	—	C.	

FIN AND BOOM

Ref. No.	Part No.	Nomenclature						No. Off	M.R.	Cl. of St.	Plate No.
		1	2	3	4	5	6				
—	—	<b>FAIRING</b> , at fin/tailplane joint (see aerofoils-tail unit)						1	—		
8023	12 TF 99A 12-2TF 101A	<b>FIN</b> , top portion, Port ... ..						1	—		BE.1
		<b>BRACKET</b> , for pitôt head ... ..						1	—	C.	BE.1
28D/8306	AS.1242/1C	Attaching parts for 12-2TF 101A, Bracket :— Bolt, 2 BA ... ..						6	—	C.	
5X/3276	12-2 TF 289A †	<b>BRACKET</b> , diaphragm, rear, on fin top fairing, Port						1	—		BE.1
		<b>BLOCK</b> , terminal ... ..						1	—	B.	
28D/8304	AS.1242/6B	Attaching parts for 5X/3276, Block :— Bolt, 4 BA ... ..						2	—	C.	
28M/10287	AGS.2001/B/1	Nut, 4 BA ... ..						2	—	C.	
28W/12305	SP.13/B	Washer ... ..						2	—	C.	
28D/8306	AS.1242/1C	Attaching parts for 12-2TF 289A, Bracket :— Bolt, 2 BA ... ..						4	—	C.	
	12-2 TF 281A	<b>FAIRING</b> , fin, top, port ... ..						1	—		BE.1
28D/8306	AS.1242/1C	Attaching parts for 12-2 TF 281A, Fairing :— Bolt, 2 BA ... ..						8	—	C.	
8845	12 TF 100A 12 TF 162A/ND	<b>FIN</b> , top portion, Starboard ... ..						1	—		BE.1
		<b>FAIRING</b> , fin top ... ..						1	MR	C.	
28D/8306	AS.1242/1C	Attaching parts for 12 TF 162A/ND, Fairing :— Bolt, 2 BA ... ..						8	—	C.	
26FC/2478	J.00484A	<b>PAD</b> , bumper at rear end of boom ... ..						1	—	C.	BE.1
		Attaching parts for J.00484A, Pad :— Bolt, 2 BA ... ..						11	—	C.	
28D/8376	AS.1243/2C	Nut, 2 BA ... ..						11	—	C.	
28M/10288	AGS.2001/C/1	Washer ... ..						11	—	C.	
28W/12252	SP.13/C										
26FC/2476	J.0064	<b>PLATE</b> , cover, for centre handhole on inboard side of boom						1	—	C.	BE.1
26FC/2475	J.0063	<b>PLATE</b> , cover, for front handhole on inboard side of boom						1	—	C.	BE.1

**AEROFOILS  
FIN AND BOOM**

Ref. No.	Part No.	Nomenclature						No Off	M.R.	Cl. of St.	Plate No.
		1	2	3	4	5	6				
26FC/2477	J.0065	<b>PLATE</b> , cover, for rear handhole on inboard side of boom						1	—	C.	BE.1
28D/8300	AS.1242/1B	Attaching parts for J.0064, J.0063 and J.0065, Plates :— Bolt, 4 BA ... ..						10	—	C.	
26FC/2479	J.00618ND	<b>PLATE</b> , cover, for handholes at boom/wing joint ...						2	—	C.	BE.1
28D/8306	AS.1242/1C	Attaching parts for J.00618ND, Plate :— Bolt, 2 BA ... ..						16	—	C.	
26FC/2493	J.00133	<b>PLATE</b> , cover, for handhole on outboard side of boom at fin						1	—	C.	BE.1
28D/8300	AS.1242/1B	Attaching parts for J.00133, Plate :— Bolt, 4 BA ... ..						16	—	C.	
26FC/3950	J.00786	<b>PLATE</b> , cover, for handhole on outboard side of fin						1	—	C.	BE.1
28D/8300	AS.1242/1B	Attaching parts for J.00786, Plate :— Bolt, 4 BA ... ..						12	—	C.	

AEROFOILS

RUDDER

Ref. No.	Part No.	Nomenclature						No Off	M.R.	Cl. of St.	Plate No.
		1	2	3	4	5	6				
8188	12-2TR 81A	<b>RUDDER</b> , (Pre Mod. Ven. 473) ... ..						2	—	A.	BF.1
9351	12-2TR 337A	<b>RUDDER</b> , (Mod. Ven. 473) ... ..						2	—	A.	BF.1
	12-2TR 109ND	<b>EDGE</b> , trailing ... ..						1	MR		BF.1
	J.001043A	<b>HINGE</b> , (Pre Mod. 473) ... ..						1	—		BF.1
28D/11740	AS.2504/13G	<b>BOLT</b> , $\frac{5}{16}$ " BSF ... ..						1	—	C.	
26FC/3357	J.00755	<b>BRACKET</b> ... ..						1	—	C.	BF.1
26FC/3358	J.00756A	<b>LINK</b> ... ..						1	—	B.	BF.1
27S/142	Skefko I.132498	<b>BEARING</b> , ball-race ... ..						1	—	B.	
28M/13122	A27/GS	<b>NUT</b> , $\frac{5}{16}$ " BSF ... ..						1	—	C.	
28P/12462	SP.9/C8	<b>PIN</b> , split ... ..						1	—	C.	
28W/12347	SP.16/G	<b>WASHER</b> ... ..						1	—	C.	
		Attaching parts for J.001043A, Hinge :—									
28D/12532	A25/4C	Bolt, 2 BA ... ..						4	—	C.	
28W/12252	SP.13/C	Washer ... ..						4	—	C.	
	J.001043A	<b>HINGE</b> (Mod. Ven. 473) ... ..						1	—		BF.1
28D/11740	AS.2504/13G	<b>BOLT</b> , $\frac{5}{16}$ " BSF ... ..						1	—	C.	
26FC/3357	J.00755	<b>BRACKET</b> ... ..						1	—	C.	
	J.001042ND	Attaching parts for J.001043A, Hinge :—									
	SP.13/C	Bolt, (Make from 28D/12532—A25/4C) ... ..						4	—		
28W/12252		Washer ... ..						4	—	C.	
26FC/4699	J.001795	<b>PEDESTAL</b> , on main post ... ..						1	MR	B.	BF.1
9370	12 TR 17	<b>PLATE</b> , locking, for tab ... ..						1	MR	C.	BF.1
	12-2TR 391A/ND	<b>RIB</b> , complete (Mod. Ven. 473) ... ..						1	—		BF.1
	12-2TR 387A/ND	<b>RIB</b> , half ... ..						1	—		BF.1
	12-2TR 389A/ND	<b>RIB</b> , half ... ..						1	—		BF.1
		Attaching parts for 12-2TR 391A/ND, Rib :—									
28D/12528	A25/1B	Bolt, 4 BA ... ..						18	—	C.	
28M/13086	A27/BP	Nut, 4 BA ... ..						18	—	C.	
28W/12305	SP.13/B	Washer ... ..						18	—	C.	
	12-2TR 83A	<b>RIB</b> , end, bottom ... ..						1	MR		BF.1
	12-2TR 231A	<b>TAB</b> , complete with attachment block ... ..						1	MR		BF.1
	12-2TR 233	<b>BLOCK</b> , attachment ... ..						1	MR		BF.1
28D/12282	AS.1242/10B	<b>BOLT</b> , 4 BA, for securing tab, bottom ... ..						1	MR	C.	
28D/11126	AS.1242/9B	<b>BOLT</b> , 4 BA, for securing tab, top ... ..						1	MR	C.	
28L/13140	A.27/BT	<b>LOCKNUT</b> , 4 BA, for bolt securing tab ... ..						2	MR	C.	
5096	12-2TR 229	<b>TAB</b> ... ..						1	MR	C.	BF.1
5093	12-2TR 217A	<b>TIP</b> , complete with mass balance ... ..						1	MR	C.	BF.1

TAILPLANE

Ref. No.	Part No.	Nomenclature						No. Off	M.R.	Cl. of St.	Place No.
		1	2	3	4	5	6				
6638	12-2TP 1A	<b>TAILPLANE</b> (less 12 TP 129, Nose Fairing) ...						1	—	A.	BG.1
26FC/2525	J.00197	<b>BLOCK</b> , clamp, at pivot bracket for trim jack ...						2	—	C.	BG.1
28D/12532	A25/4C	Attaching parts for J.00197, Block :— Bolt, 2 BA ...						2	—	C.	
26FC/3181	J.00588	<b>BRACKET</b> , hinge ...						2	—	C.	BG.1
28D/12520	A25/4E	Attaching parts for J.00588, Bracket :— Bolt, 1/4" BSF ...						4	—	C.	
26FC/3180	J.00196A	<b>BRACKET</b> , pivot, for elevator trim jack ...						2	MR	C.	BG.1
225	12 TP 21	<b>BUSH</b> , in end fitting, front spar ...						4	MR	C.	BG.1
226	12 TP 23	<b>BUSH</b> , in end fitting, rear spar ...						4	MR	C.	BG.1
27KB/93	AS.909/100P	<b>CHAIN</b> , at trim jack ...						1	—	B.	
	12 TP 105A	<b>CLIP</b> , saddle, for guide tube ...						4	—		BG.1
28D/12528	A25/1B	Attaching parts for 12 TP 105A, Clip :— Bolt, 4 BA ...						1	—	C.	
28M/10287	AGS.2001/B/1	Nut, 4 BA ...						1	—	C.	
28W/12305	SP.13/B	Washer ...						1	—	C.	
26FC/3360	J.00873	<b>FORK-END</b> , at elevator tab jack ...						1	—	C.	BG.1
26FC/2524	J.00893	Attaching parts for J.00873, Fork-end :— Bolt, 2 BA ...						1	—	C.	BG.1
28M/10288	AGS.2001/C/1	Nut ...						1	—	C.	
26FC/2517	J.00890A	<b>JACK</b> , elevator tab ...						1	—	B.	
	J.00872	<b>BARREL</b> ...						1	—		BG.1
27S/137	Skefko I.132630	<b>BEARING</b> , ball-race ...						1	—	B.	BG.1
	J.00526A	<b>BODY</b> ...						1	—		BG.1
28D/12516	A25/11C	<b>BOLT</b> , 2 BA, through barrel and body ...						1	—	C.	
28D/8507	AS.1242/5C	<b>BOLT</b> , 2 BA, through body and retaining plate ...						4	—	C.	
26FC/3060	G.00656A	<b>NIPPLE</b> , complete with elbow and extension piece ...						1	—	C.	BG.1
26FN/449	24425	<b>ELBOW</b> , Tecalemit ...						1	—	C.	
28N/9796	SP/21	<b>NIPPLE</b> , grease ...						1	—	C.	
26FC/10330	9807	<b>PIECE</b> , extension, Tecalemit ...						1	—	C.	
28M/12929	A27/CP	<b>NUT</b> , 2 BA, for bolt through body and retaining plate ...						4	—	C.	
28M/13121	A27/CS	<b>NUT</b> , 2 BA, for bolt through barrel and body ...						1	—	C.	
28M/13122	A27/GS	<b>NUT</b> , 5/16" BSF, on operating spindle ...						1	—	C.	
28P/12462	SP.9/C8	<b>PIN</b> , split ...						2	—	C.	
	J.00367	<b>PLATE</b> , retaining, for ball-race bearing ...						1	—		BG.1
26FC/6726	DHS.69D	<b>SHIM</b> , for maintaining position of nipple assembly ...						QR	—	C.	
	J.00525	<b>SPINDLE</b> , operating ...						1	—		BG.1
26BY/244	D.98435	<b>SPROCKET</b> , on operating spindle ...						1	—	C.	BG.1
28W/12254	SP.13/G	<b>WASHER</b> , under nut on operating spindle ...						1	—	C.	
26FC/2514	J.00359	Attaching parts for J.00890A, Jack :— Pin, pivot ...						2	—	C.	BG.1
26FC/3187	J.001015A	<b>PLATE</b> , attachment, for rear fairing ...						2	MR	C.	BG.1
26FC/2519	J.00263	<b>PLATE</b> , cover, for access to trim cables ...						1	—	C.	BG.1
28D/8306	AS.1242/1C	Attaching parts for J.00263, Plate :— Bolt, 2 BA ...						6	—	C.	

**AEROFOILS  
TAILPLANE**

Ref. No.	Part No.	Nomenclature						No. Off	M.R.	Cl. of Sc.	Plate No.
		1	2	3	4	5	6				
26FC/2520	J.00264	<b>PLATE</b> , cover, for access to trim jack ... ..						1	—	C.	BG.1
		Attaching parts for J.00264, Plate :—									
28D/8306	AS.1242/1C	Bolt, 2 BA ... ..						8	—	C.	
1092	12 TP 83A	<b>RIB</b> , nose end ... ..						2	MR	C.	BG.1
26FC/3179	J.00874	<b>SLEEVE</b> , bearing, for fork-end ... ..						1	—	C.	BG.1
		Attaching parts for J.00874, Sleeve :—									
28D/12513	A25/2C	Bolt, 2 BA ... ..						4	—	C.	
26FC/8651	J.00261	<b>TUBE</b> , guide, for elevator trim cables, 1½" × 22 SWG × 34-0" long, DTD.310						1	—	C.	BG.1
		Attaching parts for J.00261, Tube :—									
28D/12528	A25/1B	Bolt, 4 BA ... ..						4	—	C.	
28M/10287	AGS.2001/B/1	Nut, 4 BA ... ..						4	—	C.	

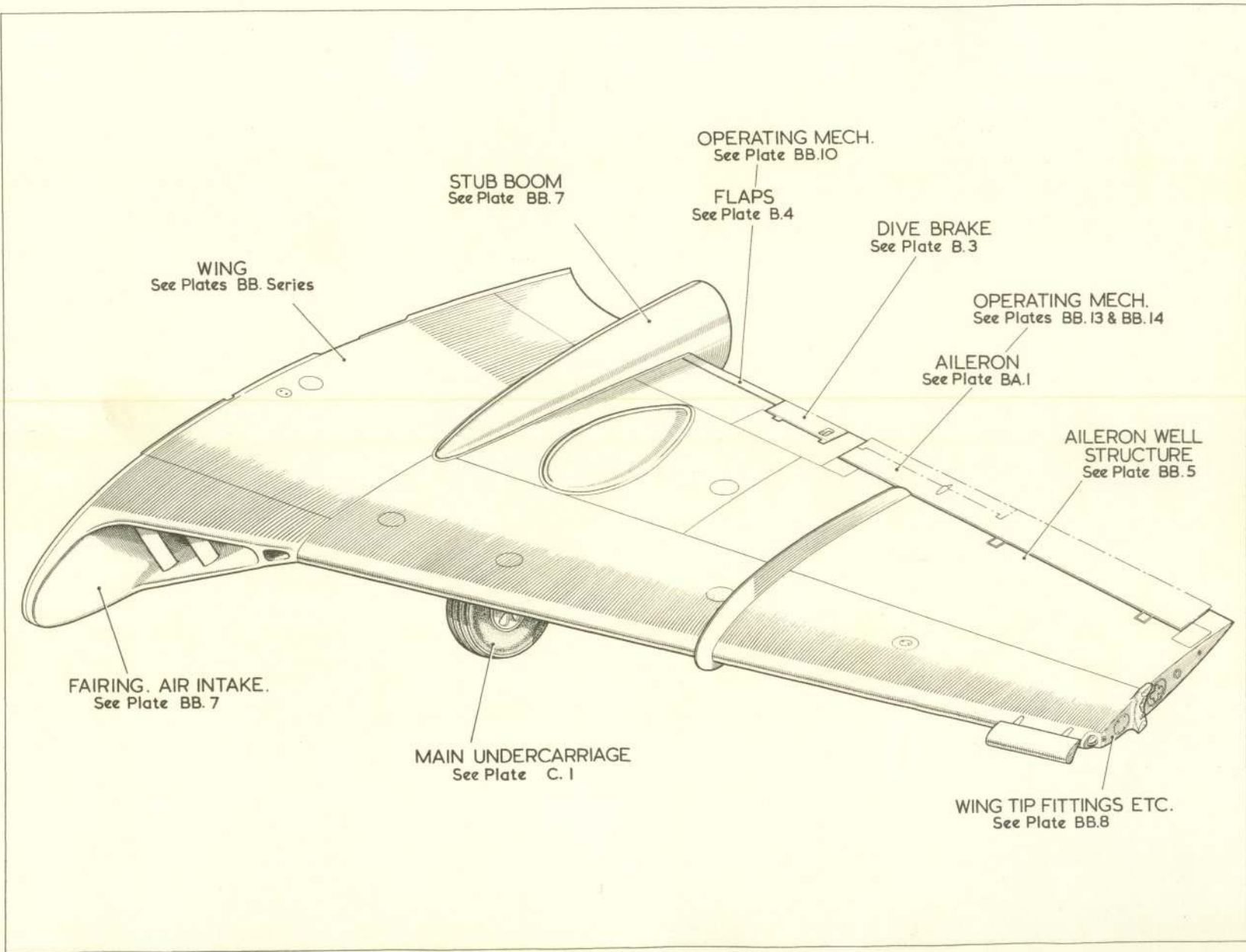

B.1.

# AEROFOILS

## WING ARRANGEMENT

RESTRICTED

B.1.

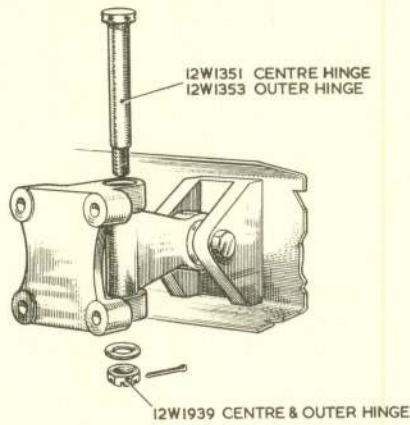

AILERON ATTACHING PARTS

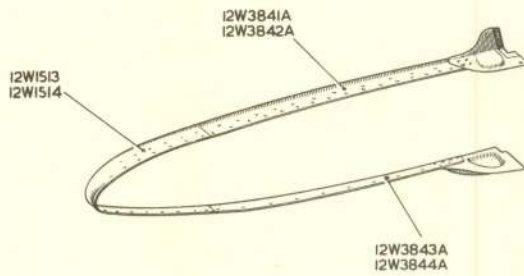

FILLETS, WING ROOT

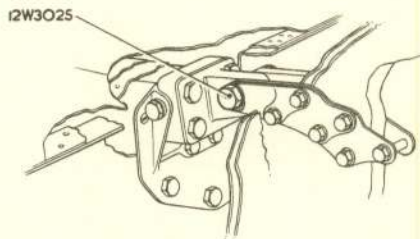

VIEW LOOKING OUTBOARD R.H.

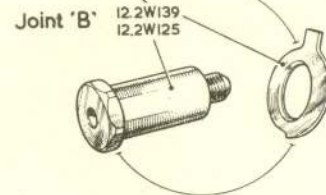
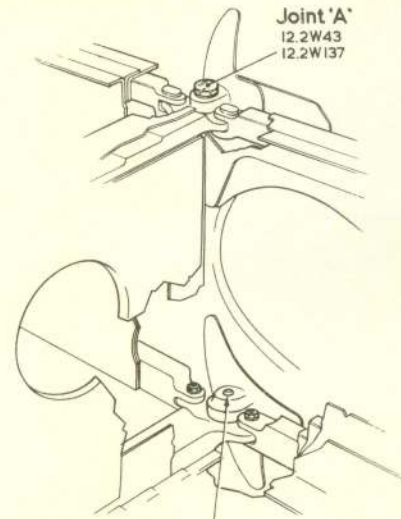

JOINTS 'A' & 'B', MAINPLANE TO FUSELAGE

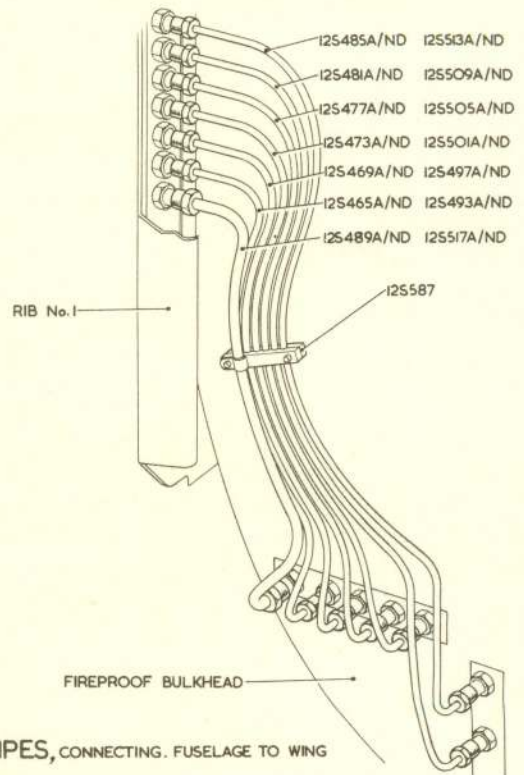

B.2.

# AEROFOILS

## WING ARRANGEMENT

B.2.

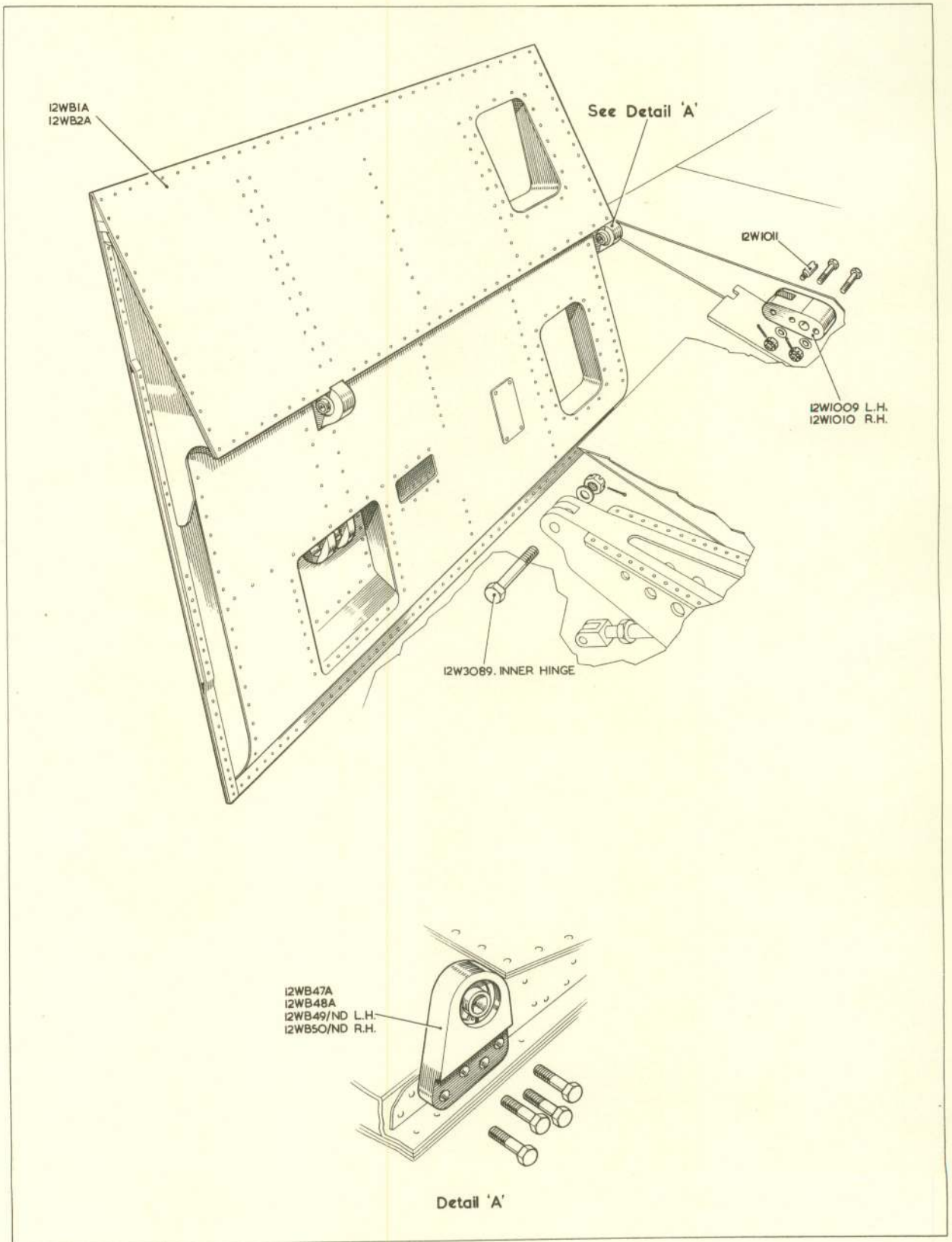

B.3.

# AEROFOILS

## WING ARRANGEMENT

B.3.

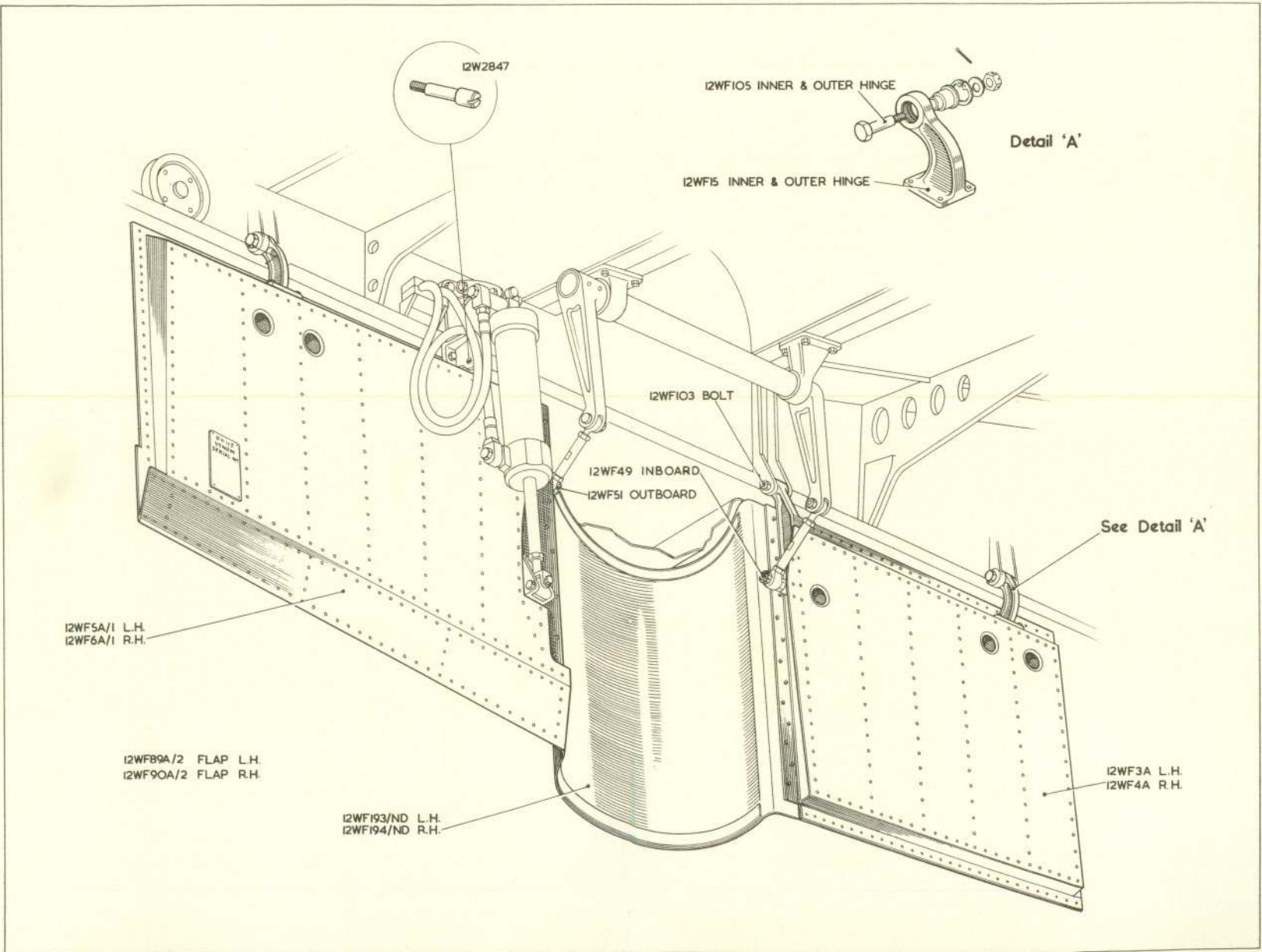

B.4.

**AEROFOILS  
WING ARRANGEMENT**

RESTRICTED

B.4.

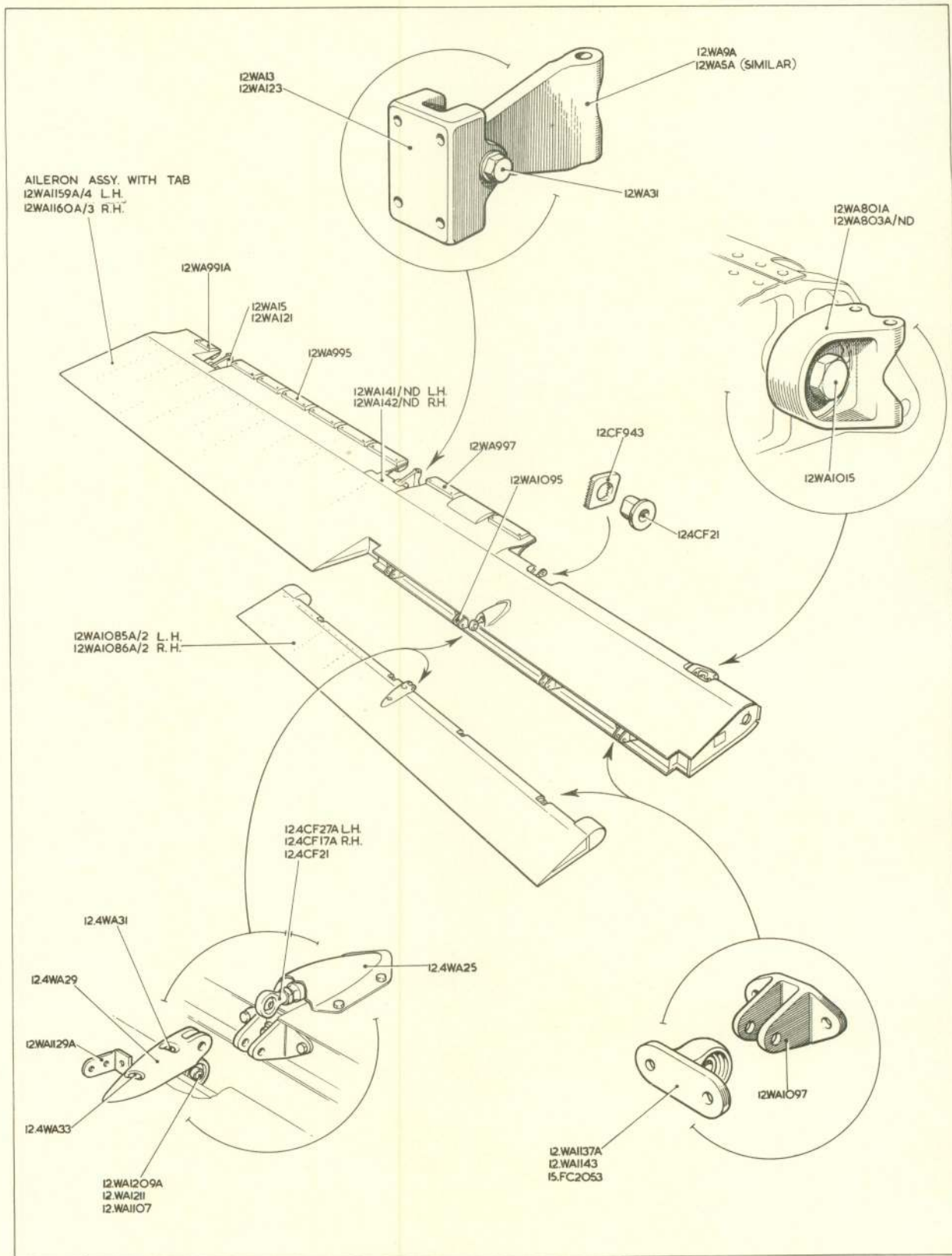

BA.I.

# AEROFOILS

BA.I.

## AILERON

RESTRICTED



BB.2.

# AEROFOILS

BB.2.

## WING STRUCTURE

RESTRICTED

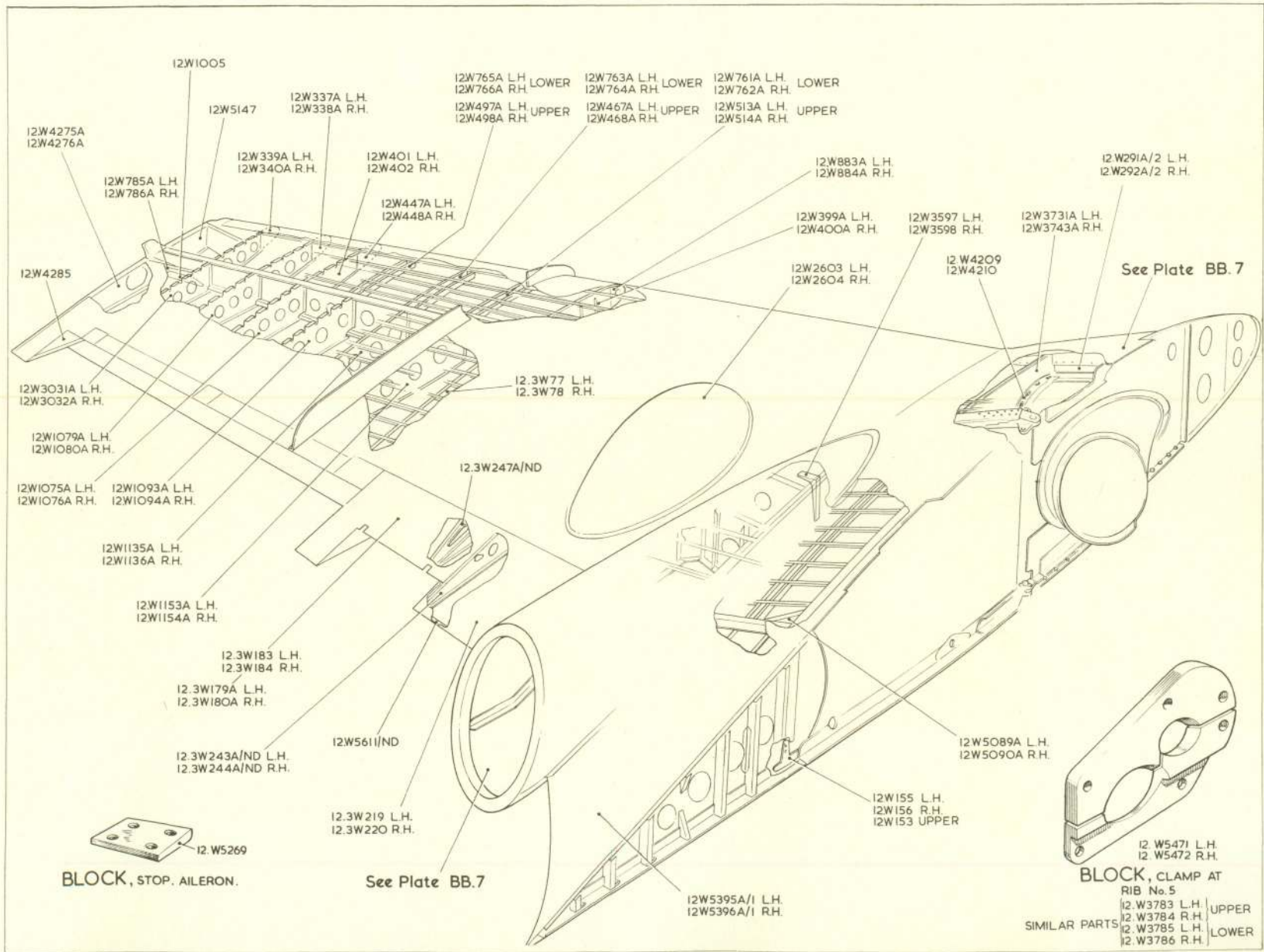

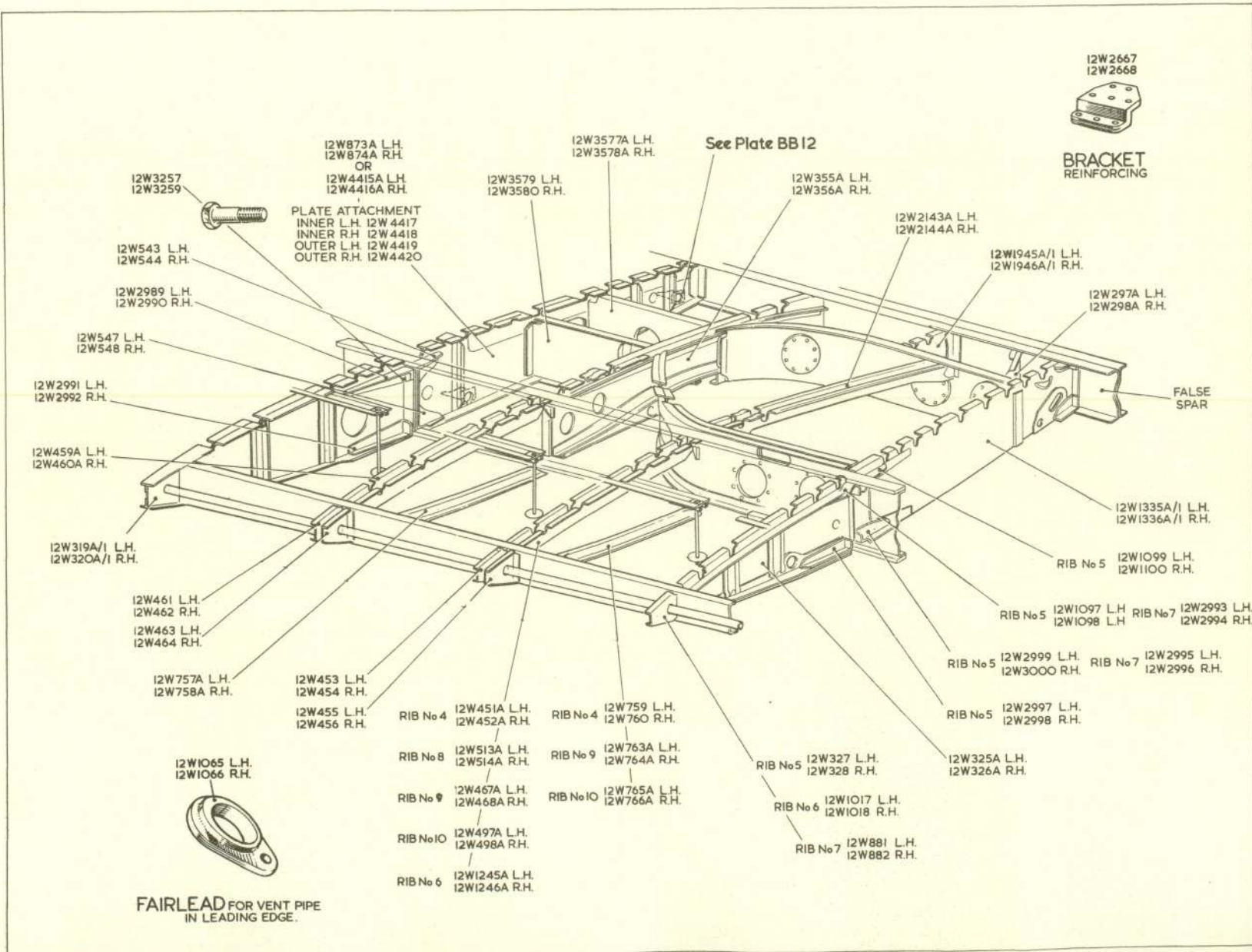

BB.3.

**AEROFOILS**

**WING**

**RIBS AND FITTINGS**

RESTRICTED

BB.3.

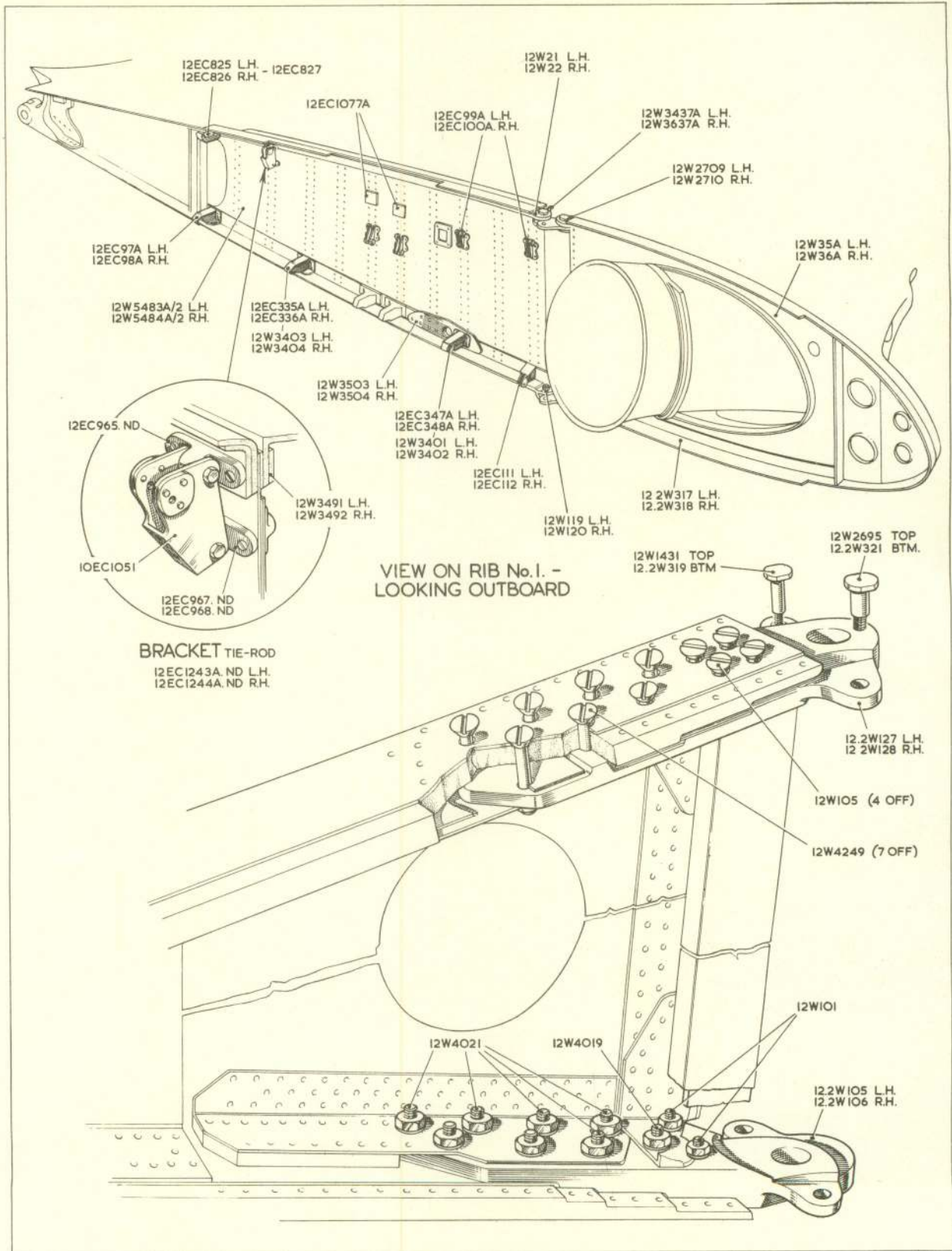

BB.4.

# AEROFOILS

BB.4.

## WING - DETAILS

BB.5.

**AEROFOILS**  
**WING**  
**STRUCTURE AND FITTINGS**  
RESTRICTED

BB.5.

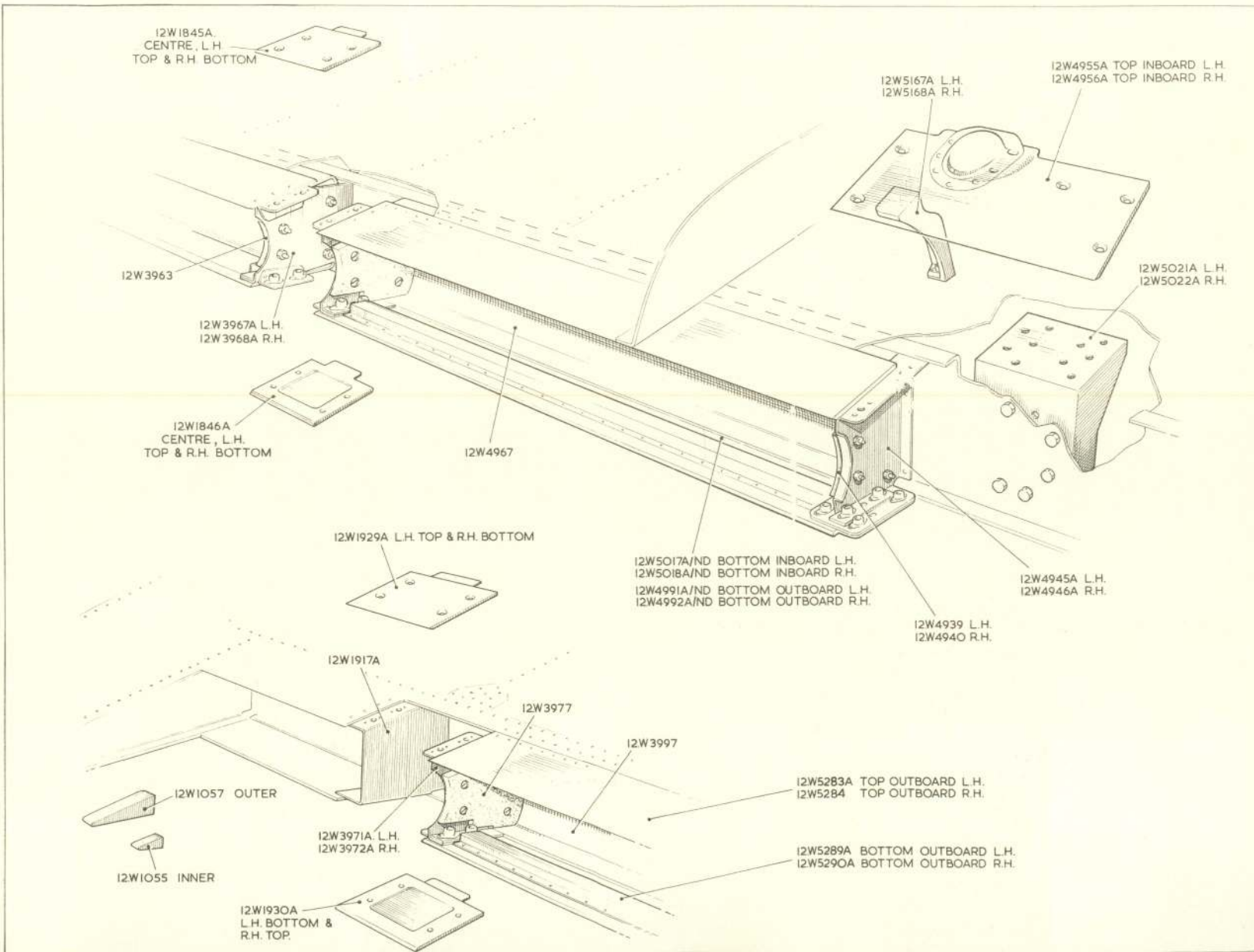

Venom FB Mk. 4

RESTRICTED

Plate BB5

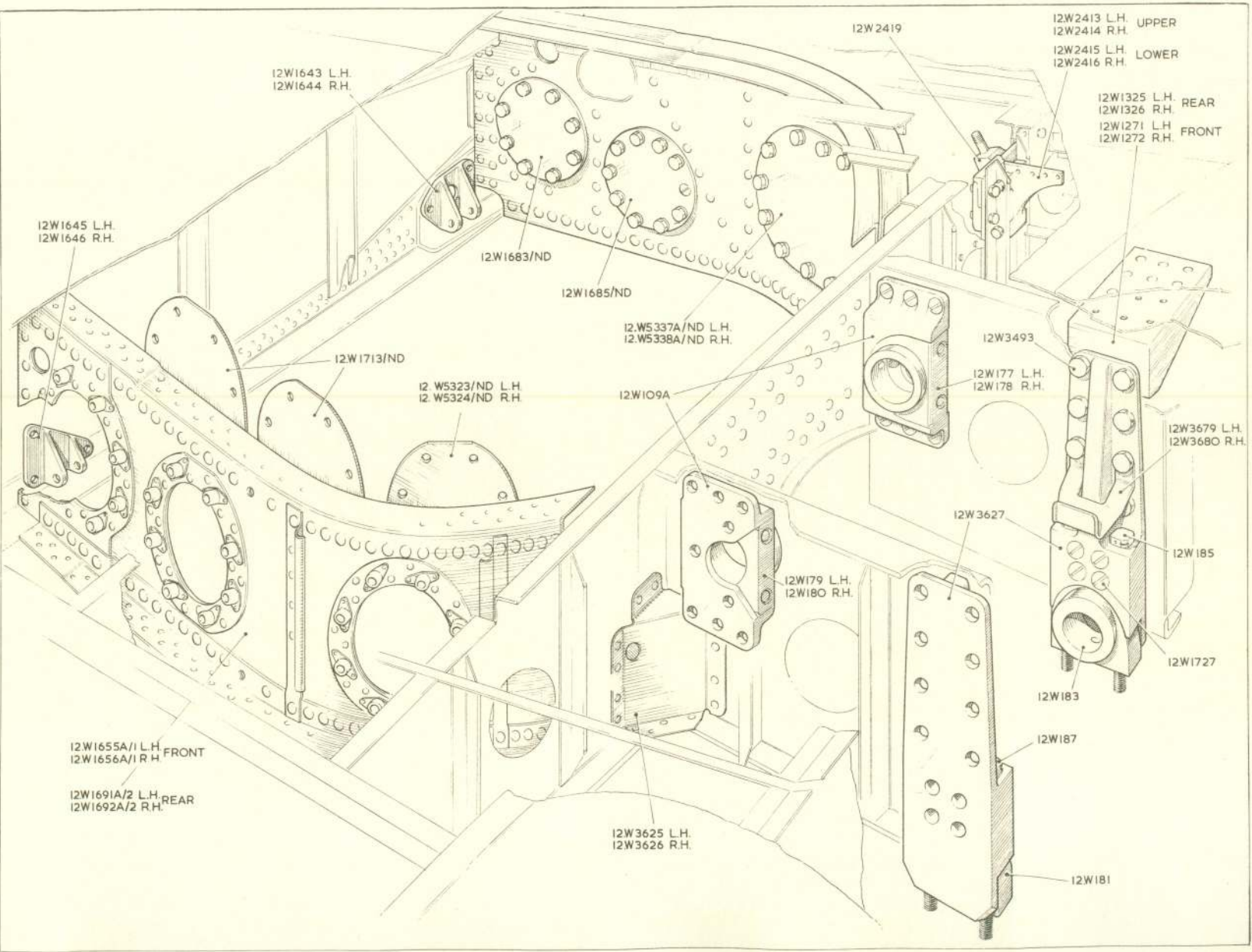

BB.6.

**AEROFOILS  
WING  
FITMENTS**

RESTRICTED

BB.6.

Venom FB Mk. 4

RESTRICTED

Plate B86

BB.7.

# AEROFOILS

## WING DETAILS

RESTRICTED

BB.7.

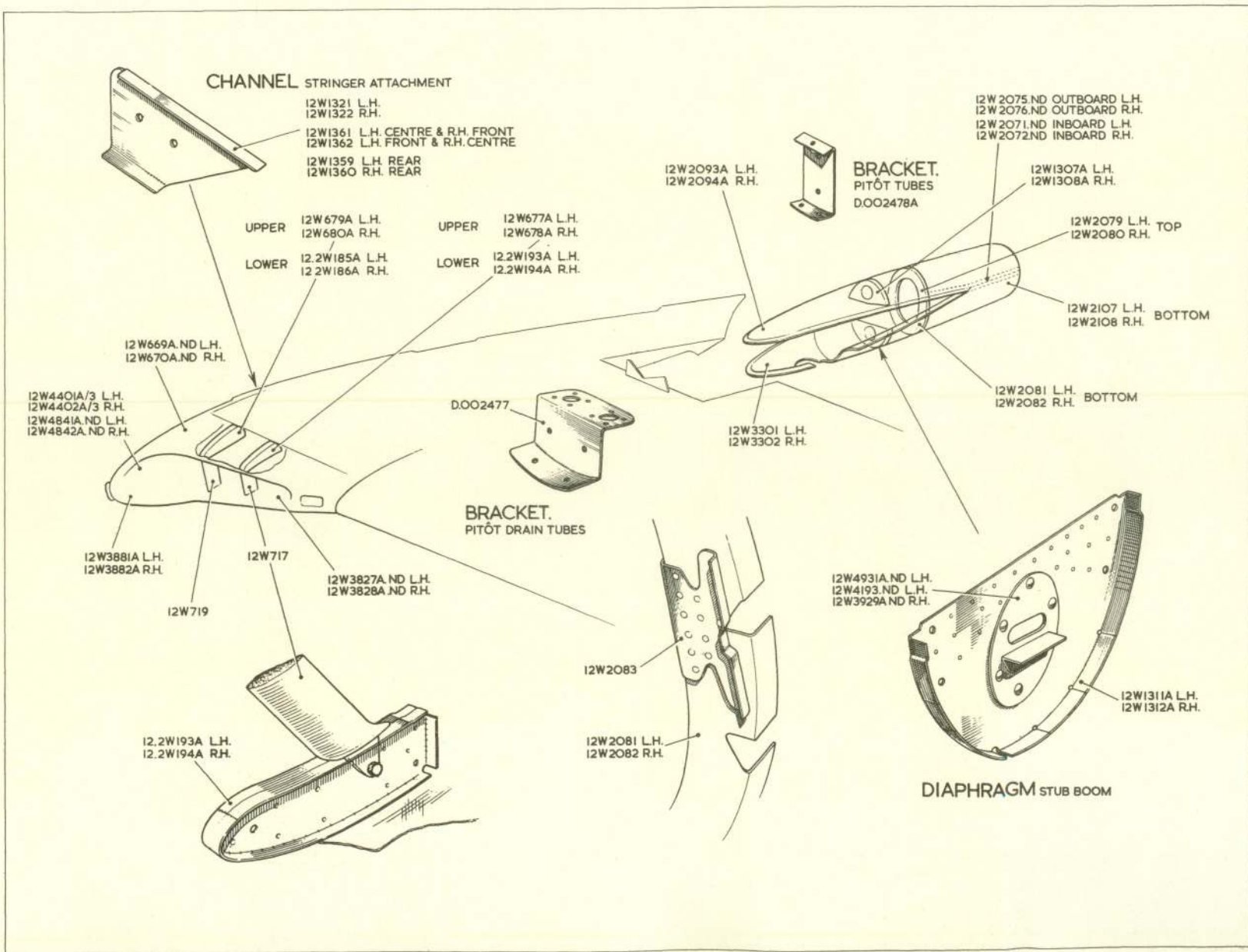

BB.8.

**AEROFOILS**

BB.8.

**WING  
FITMENTS**  
RESTRICTED

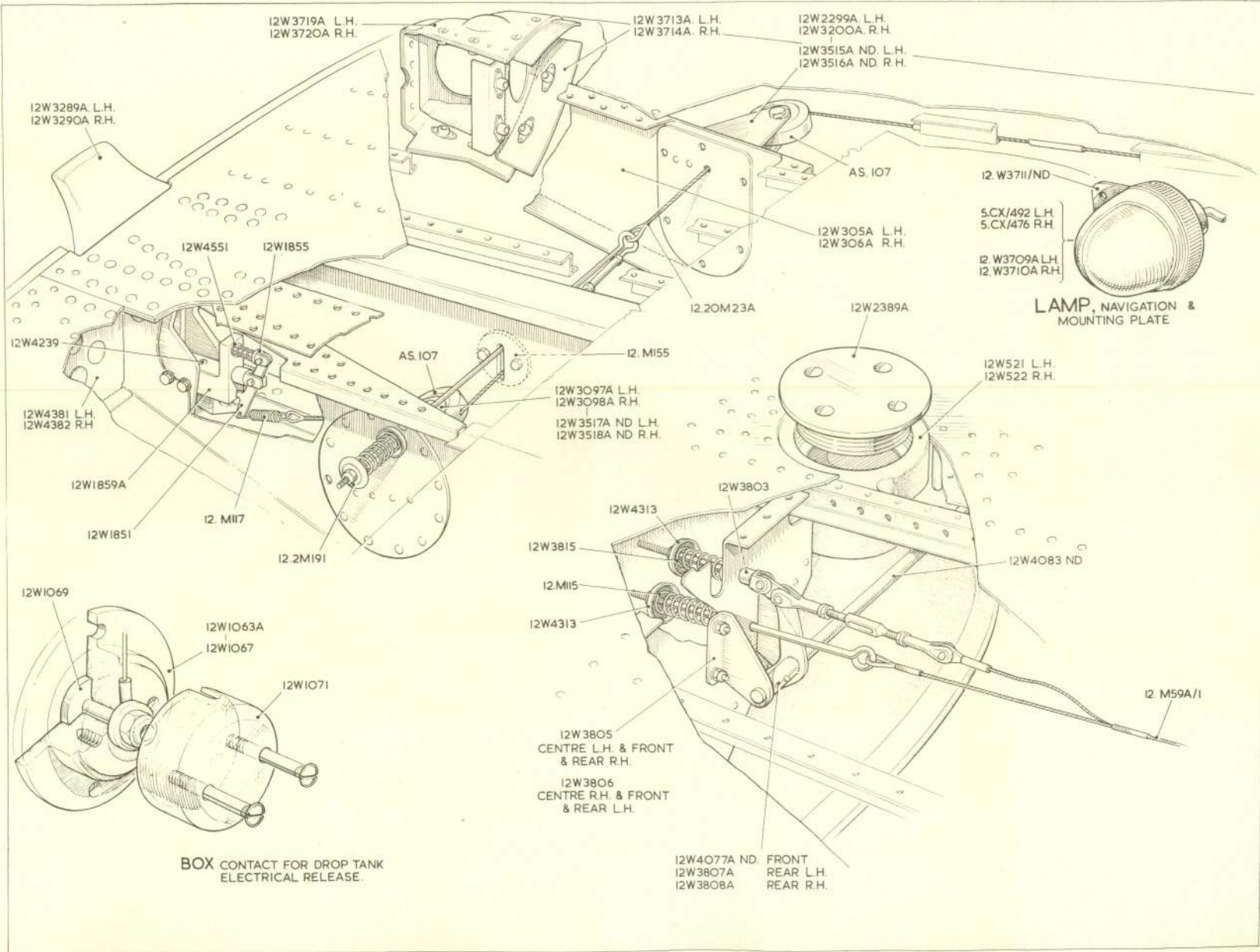

Venom FB Mk. 4

RESTRICTED

Plate 888

BB.9.

# AEROFOILS

## WING DETAILS

RESTRICTED

BB.9.

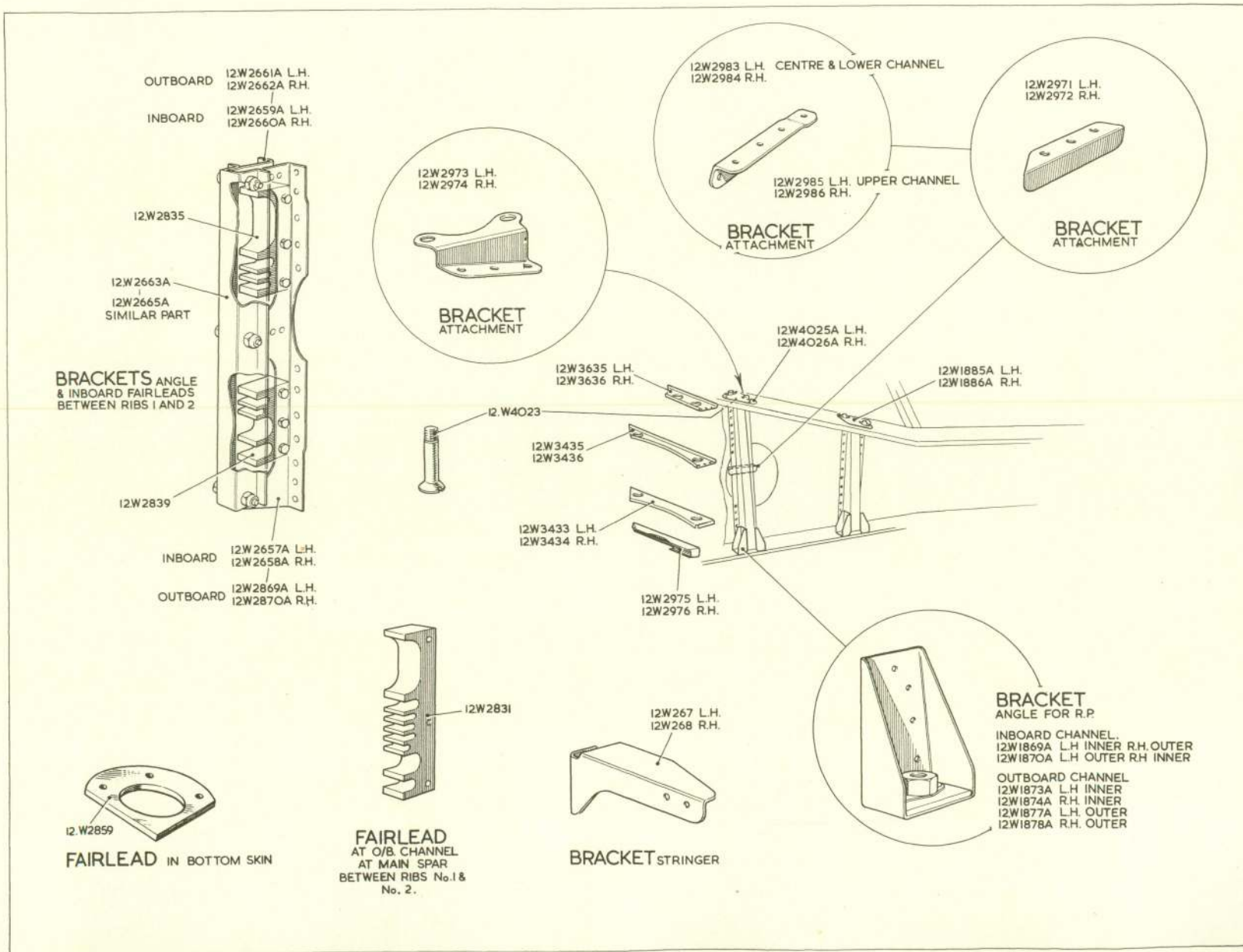

Venom FB. Mk. 4

RESTRICTED

Plate 889

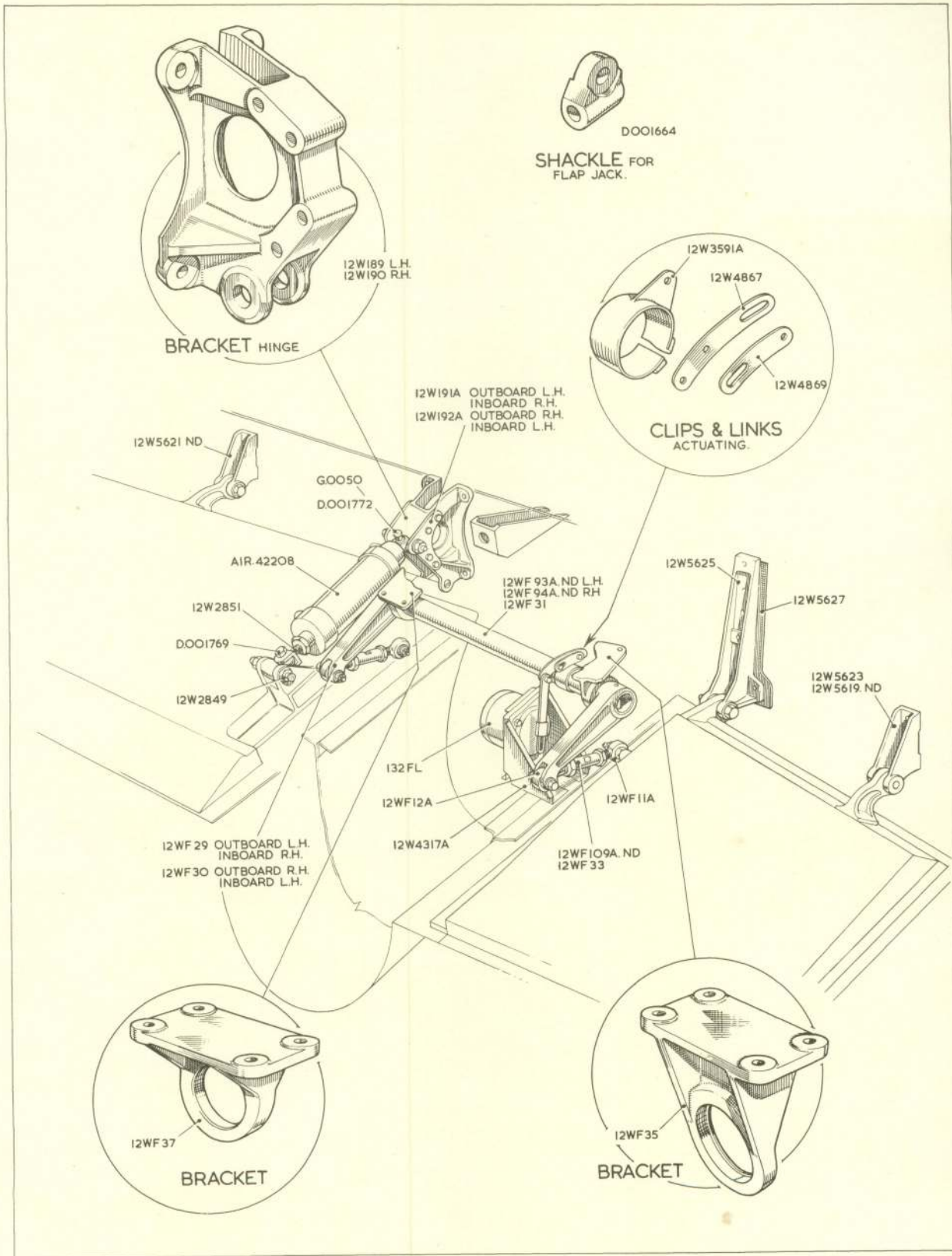

BB.10.

# AEROFOILS

BB.10.

## WING FOLD MECHANISM

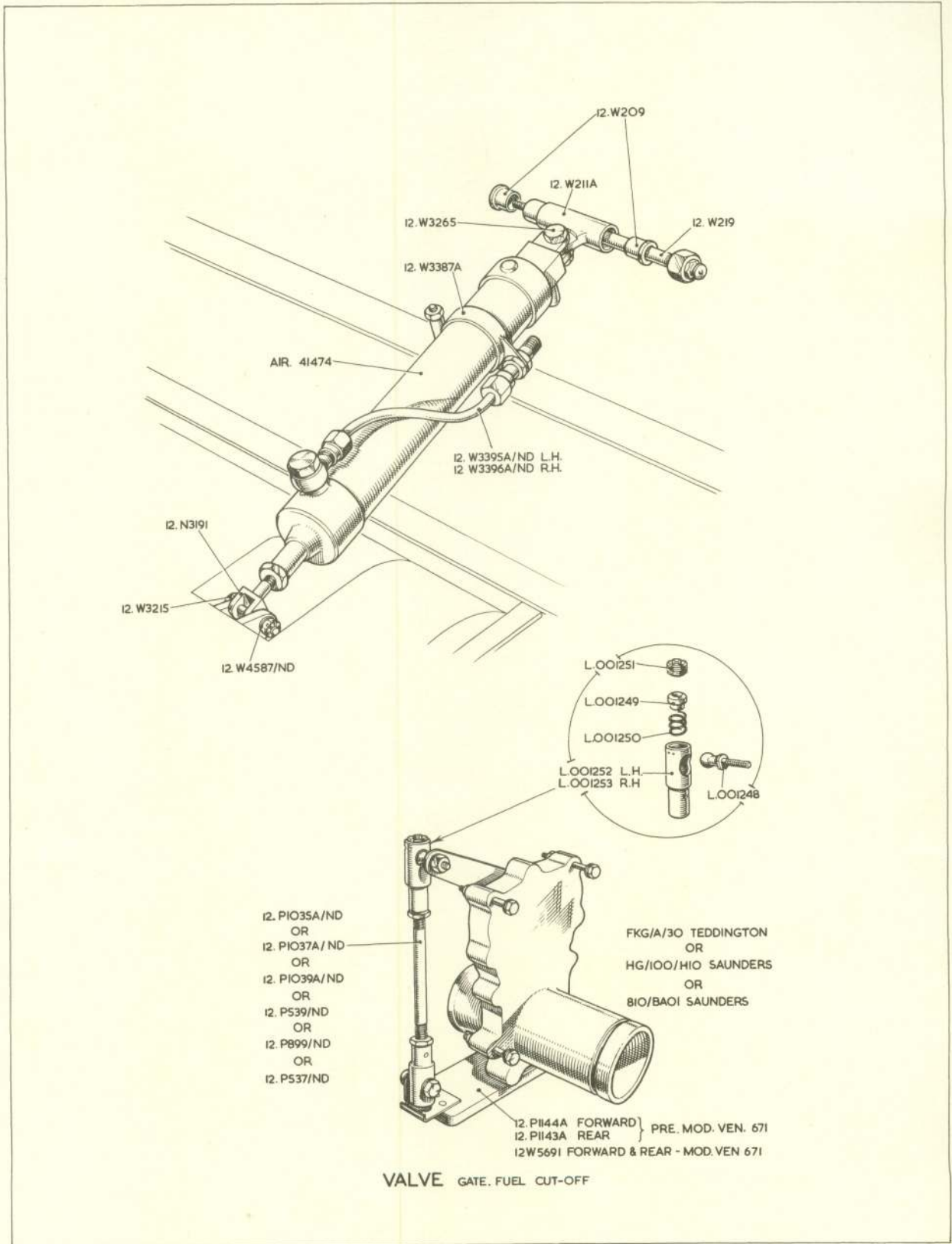

BB.11.

# AEROFOILS

BB.11.

## WING DETAILS



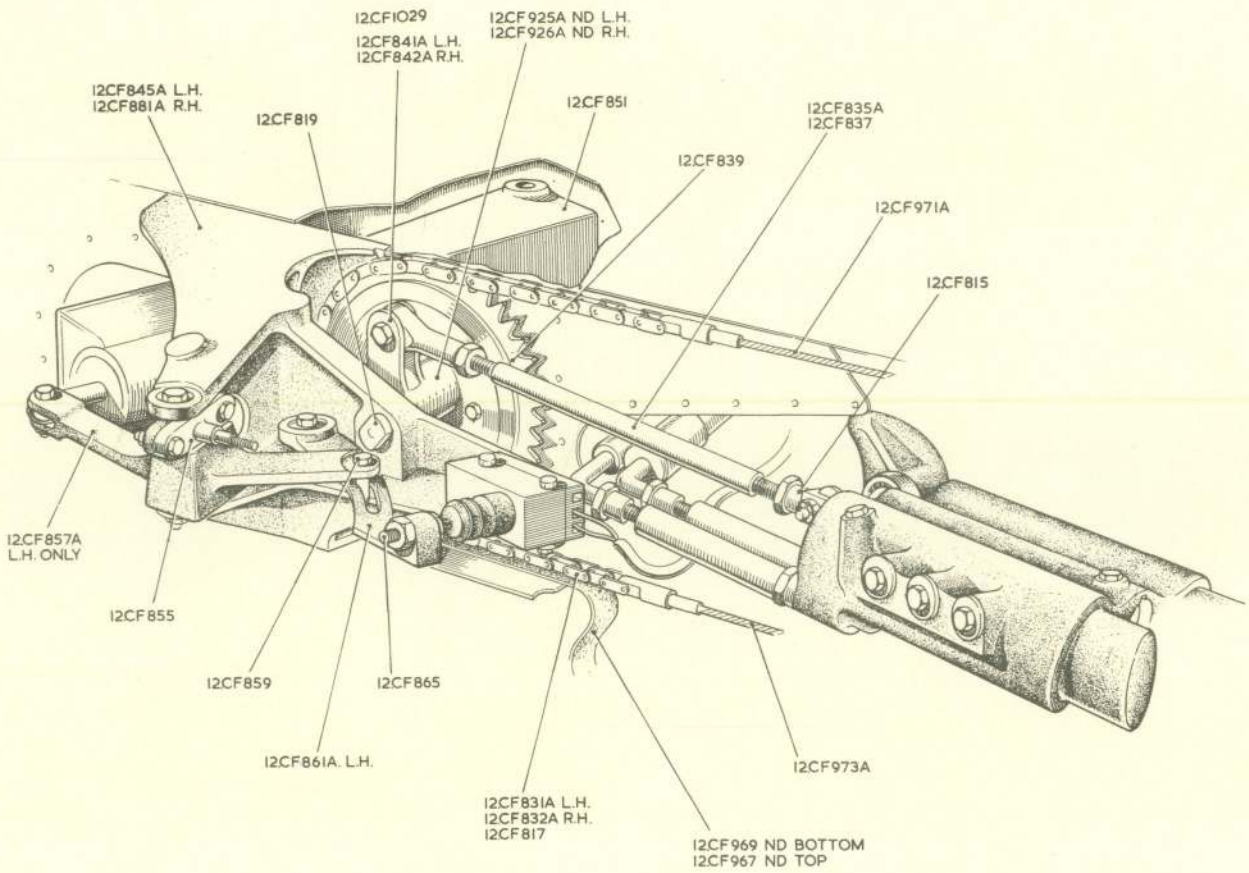

BB.13.

**AEROFOILS**  
**WING**  
**AILERON MECHANISM**  
RESTRICTED

BB.13.

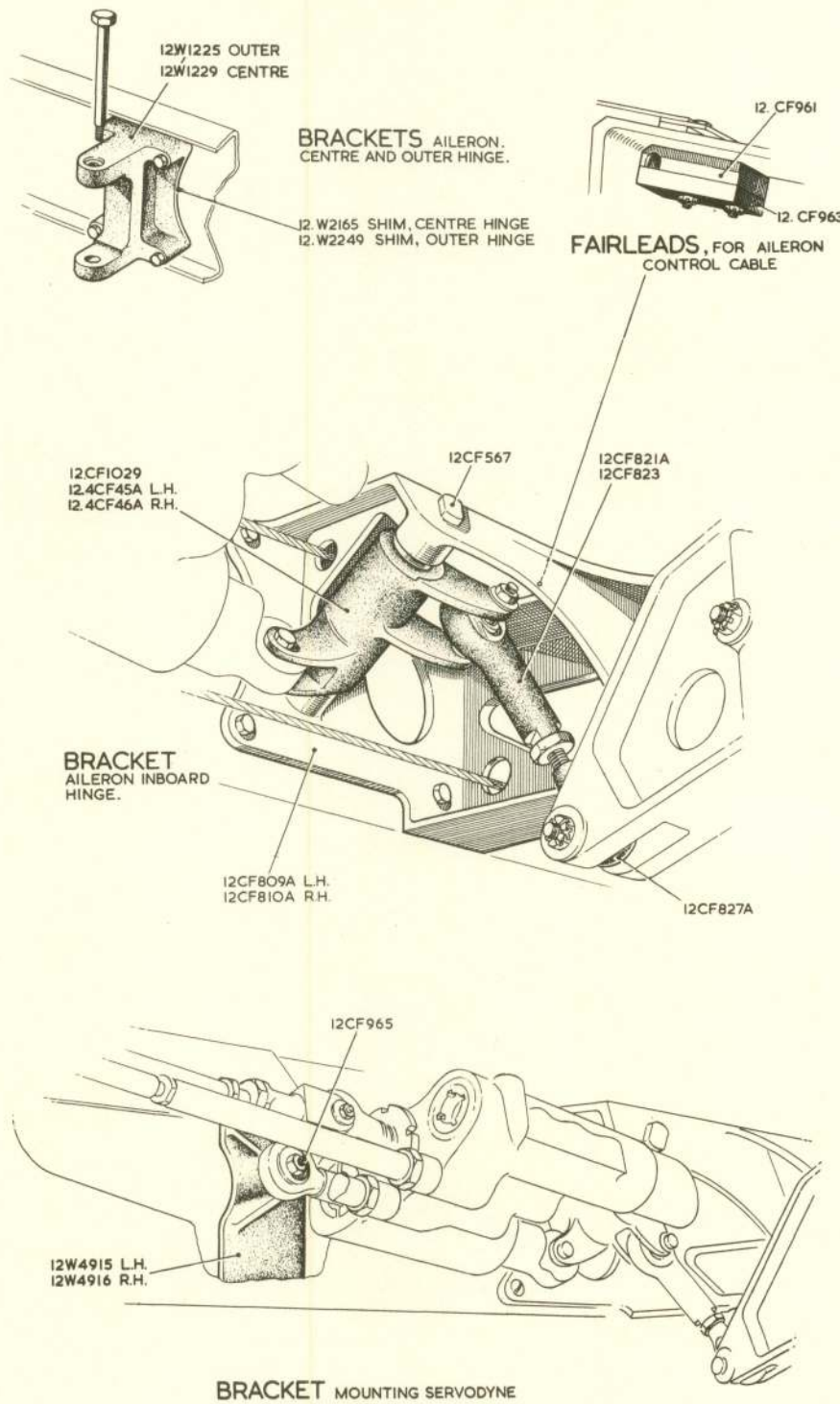

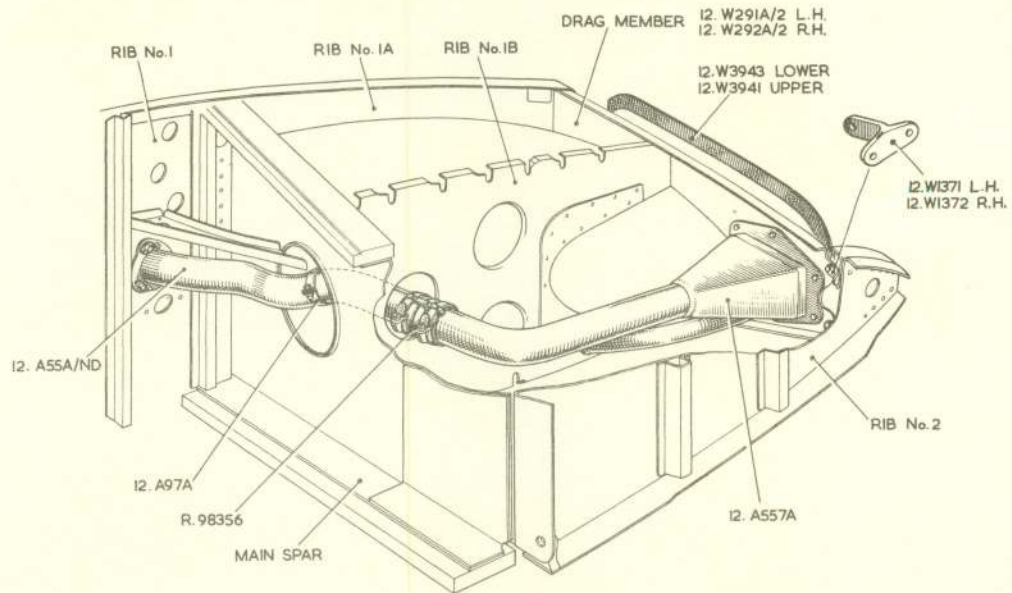

STARBOARD WING

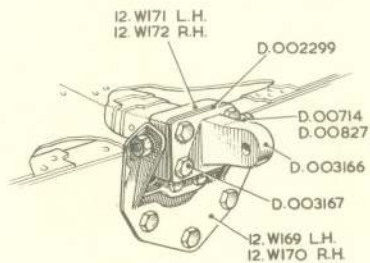

WING JOINT 'C'

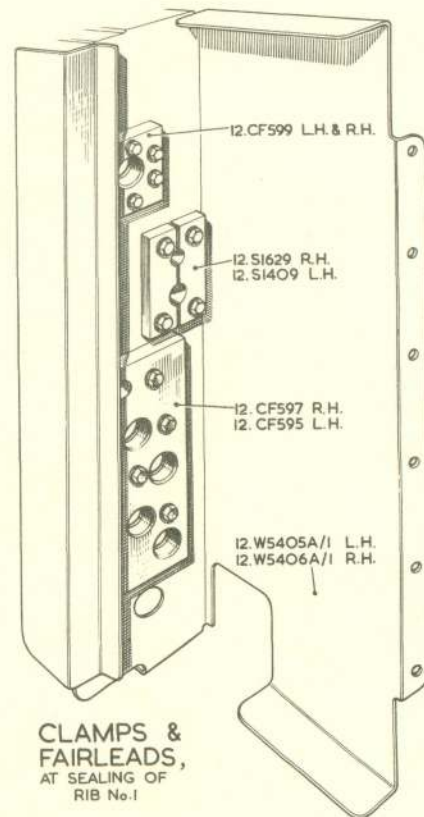
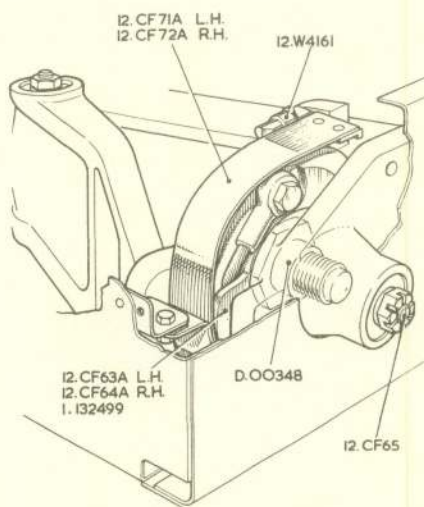

CLAMPS & FAIRLEADS, AT SEALING OF RIB No.1

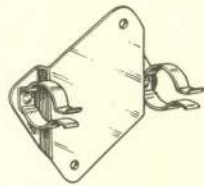

BRACKET & SPRING CLIPS  
N.OO2619A

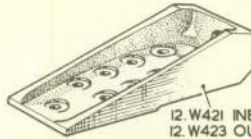

BRACKET, REINFORCING

12.W421 INBOARD LOWER, O/B. UPPER  
12.W423 OUTBOARD LOWER, I/B. OUTER

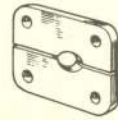

BLOCK, CLAMP  
12.M157/8

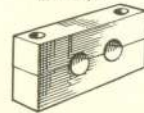

BLOCK, CLAMP  
12.M301, 12.M302,  
12.M303, 12.M304.

BRACKET, MOUNTING



12.U355

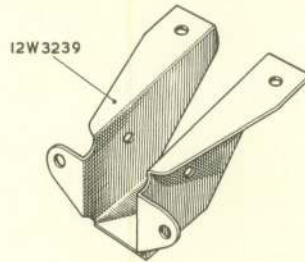

12W3239

BRACKET FAIRLEAD

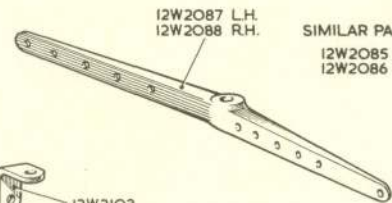

12W2087 L.H.  
12W2088 R.H.

SIMILAR PARTS  
12W2085 L.H.  
12W2086 R.H.



12W2103

UNDERCARRIAGE DIAPHRAGM DRAG  
MEMBERS TO RIB No 2

12EC1077A

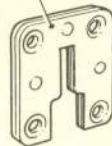
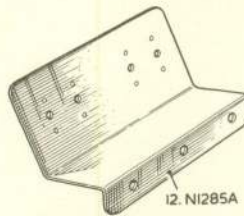

PLATE SOCKET



12.NI285A

BRACKET, MOUNTING FOR  
TERMINAL BLOCK

12W2913A L.H.  
12W2914A R.H.

SIMILAR PARTS  
12W2909A  
12W2917A L.H.  
12W2918A R.H.



PLATE NUT, IN BOTTOM SKIN

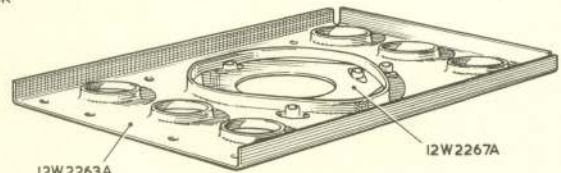

12W2263A

12W2267A

PLATE SUPPORT FOR G45 COMPASS  
DETECTOR UNIT IN STARBOARD WING.

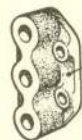

12W1763

FRONT LOWER

12W1765 L.H.  
12W1766 R.H.

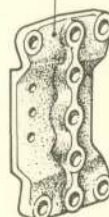

FRONT UPPER

LOWER.  
12W1769 L.H.  
12W1770 R.H.  
UPPER.  
12W1767 L.H.  
12W1768 R.H.

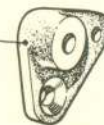

REAR, UPPER AND  
LOWER.

BLOCKS PACKING ON RIB No. 3

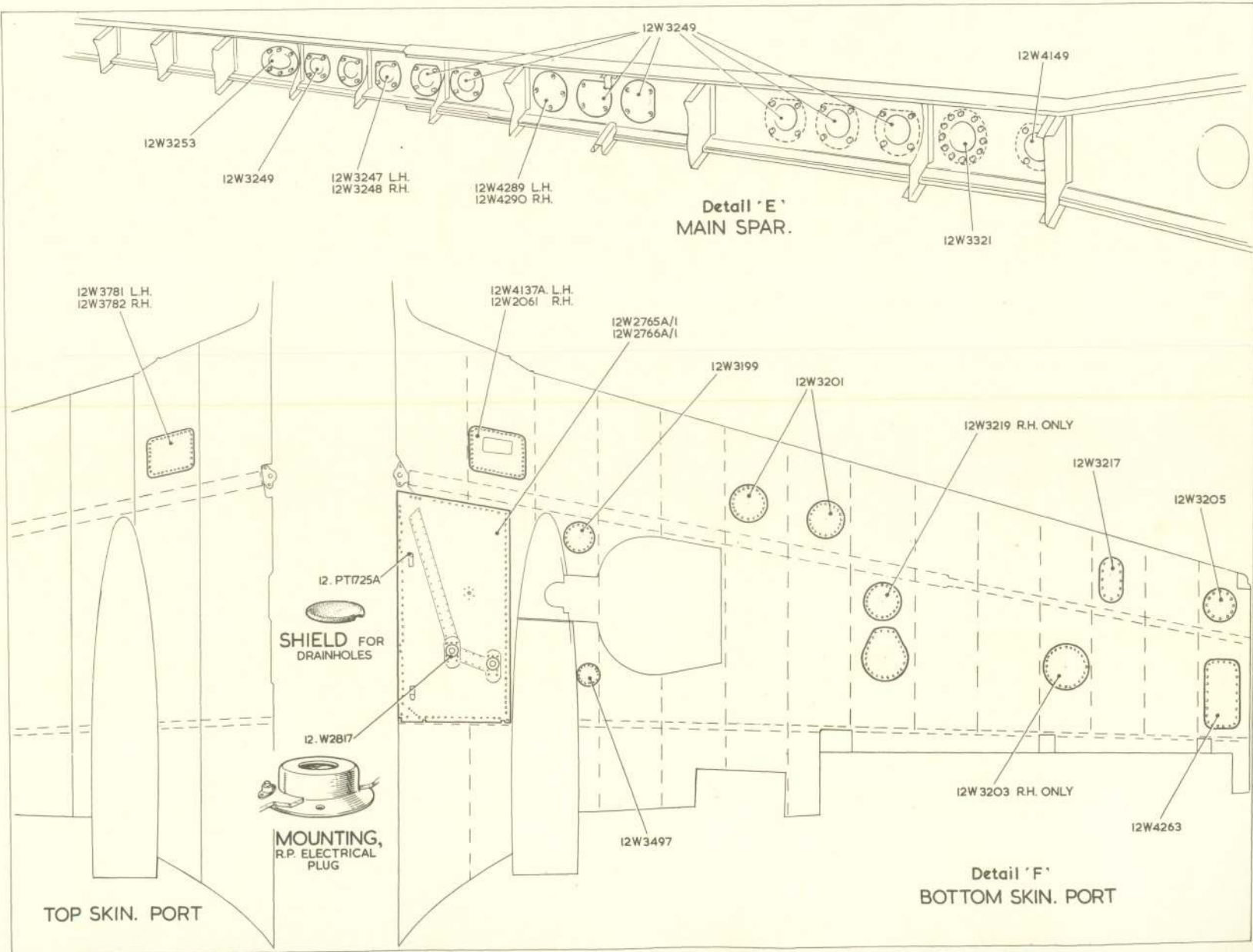

BB.17.

**AEROFOILS**  
**WING**  
**ACCESS PANELS**

RESTRICTED

BB.17.

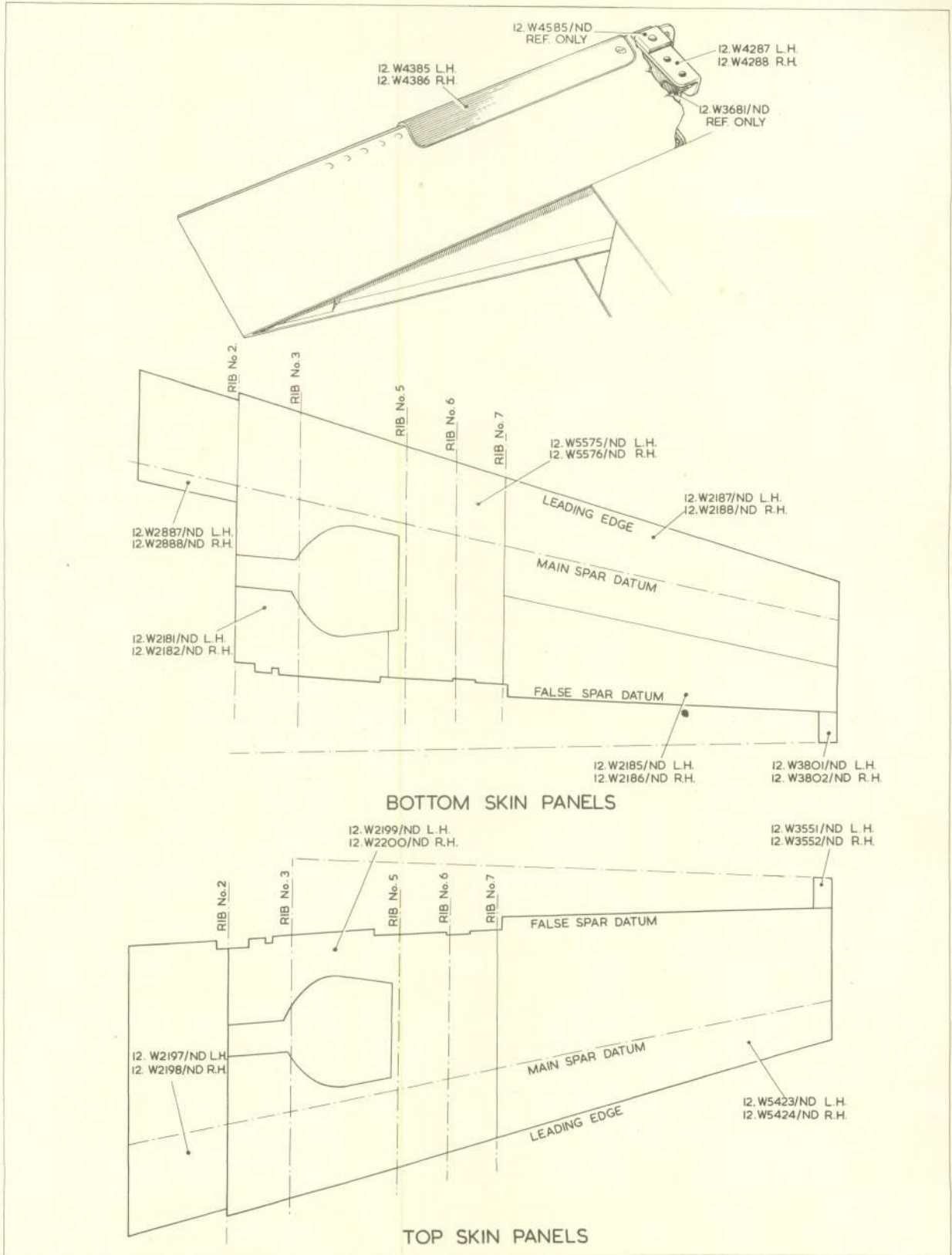

BB.18.

**AEROFOILS  
WING  
SKIN PANELS**

BB.18.

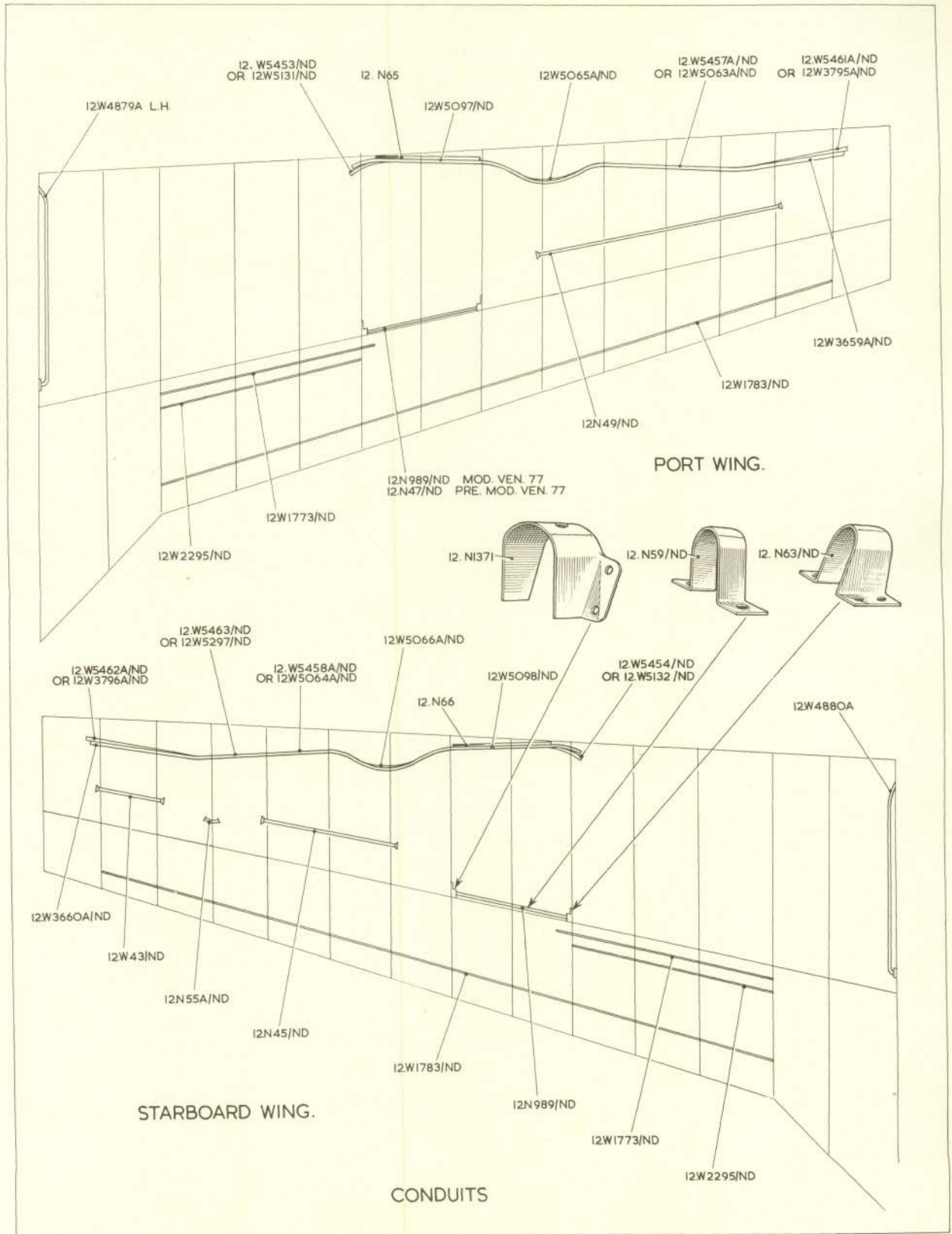

BB.19.

**AEROFOILS  
WING  
CONDUITS**  
RESTRICTED

BB.19.

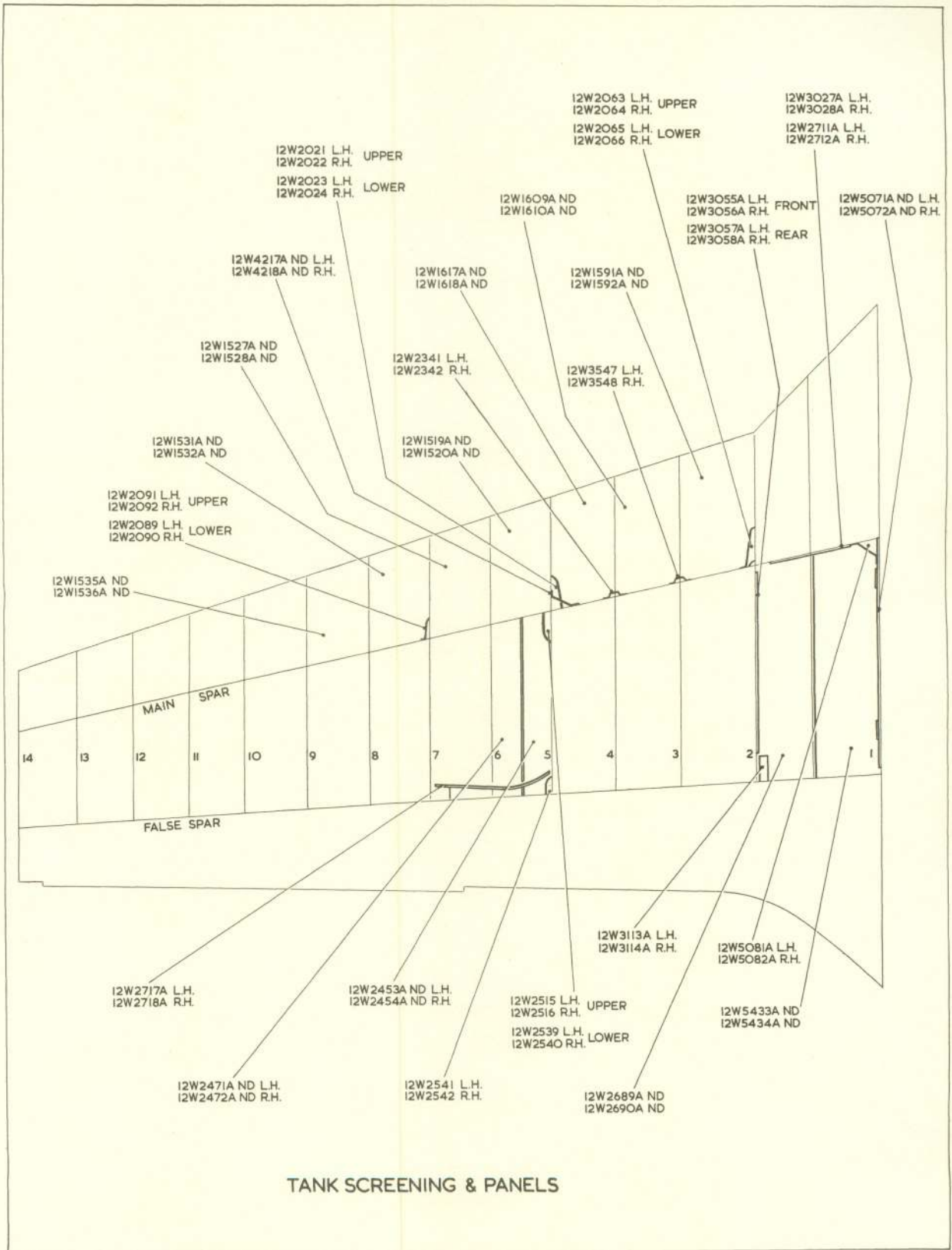

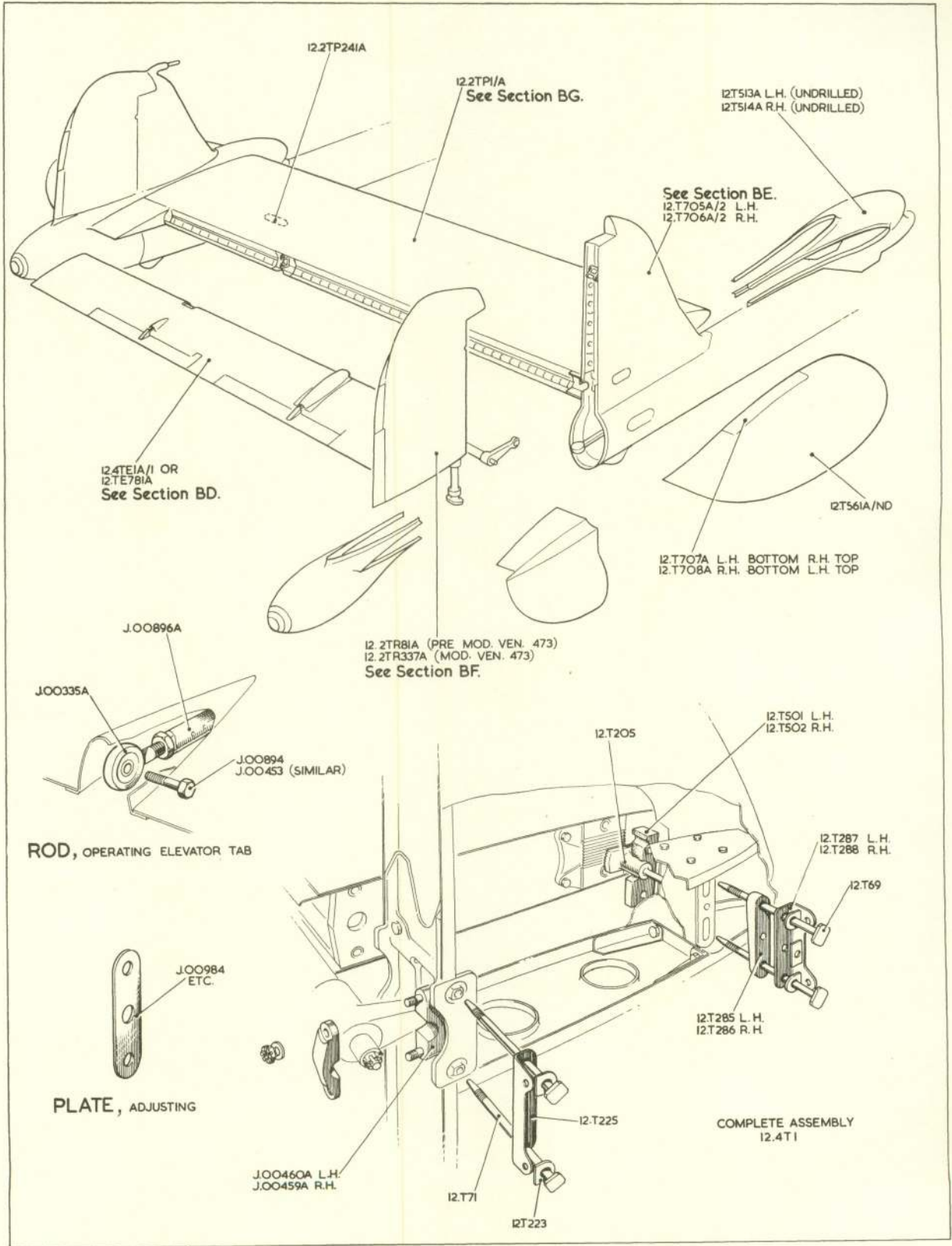

BC.I.

# AEROFOILS

BC.I.

## TAIL UNIT

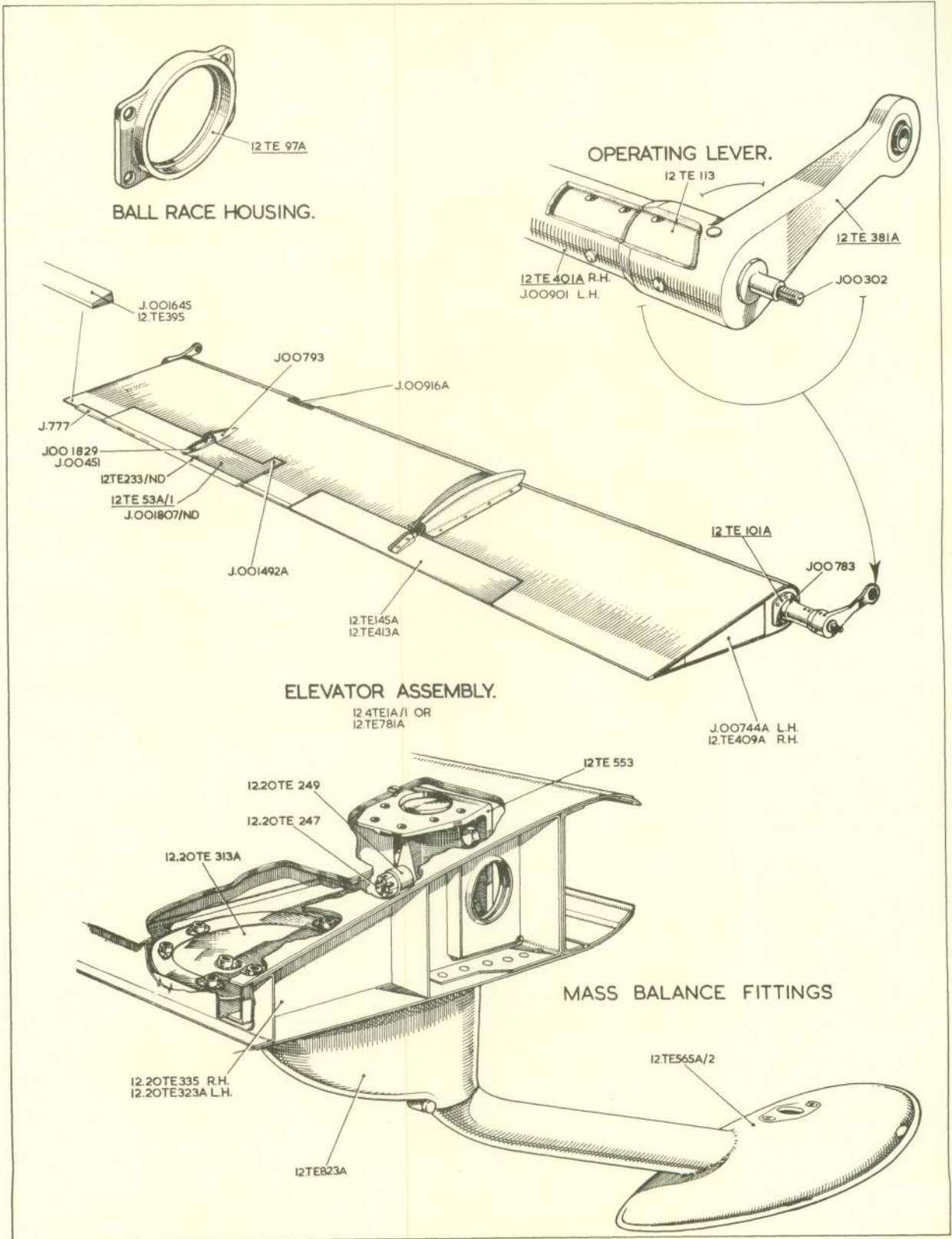

BD.I.

# AEROFOILS

BD.I.

## ELEVATOR

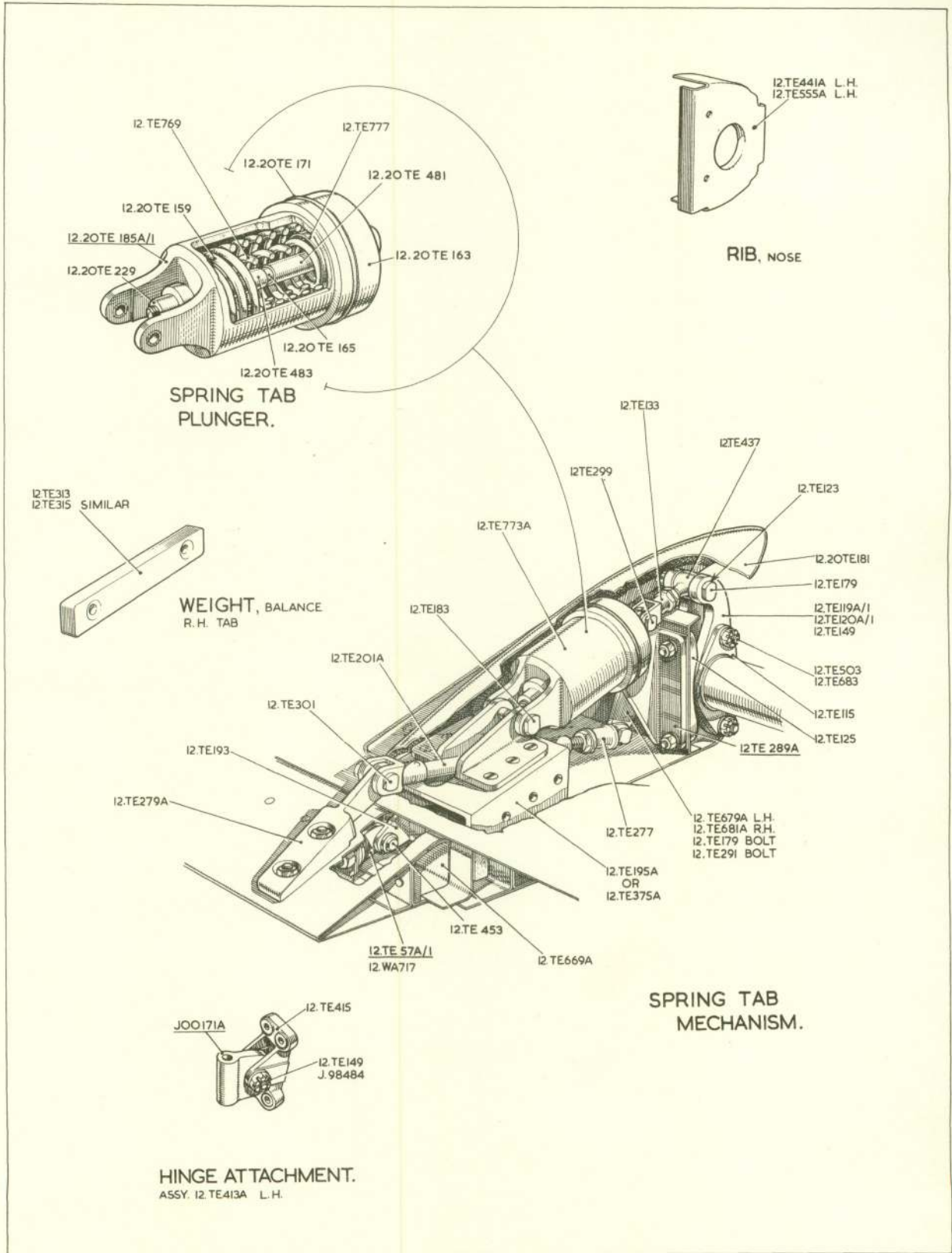

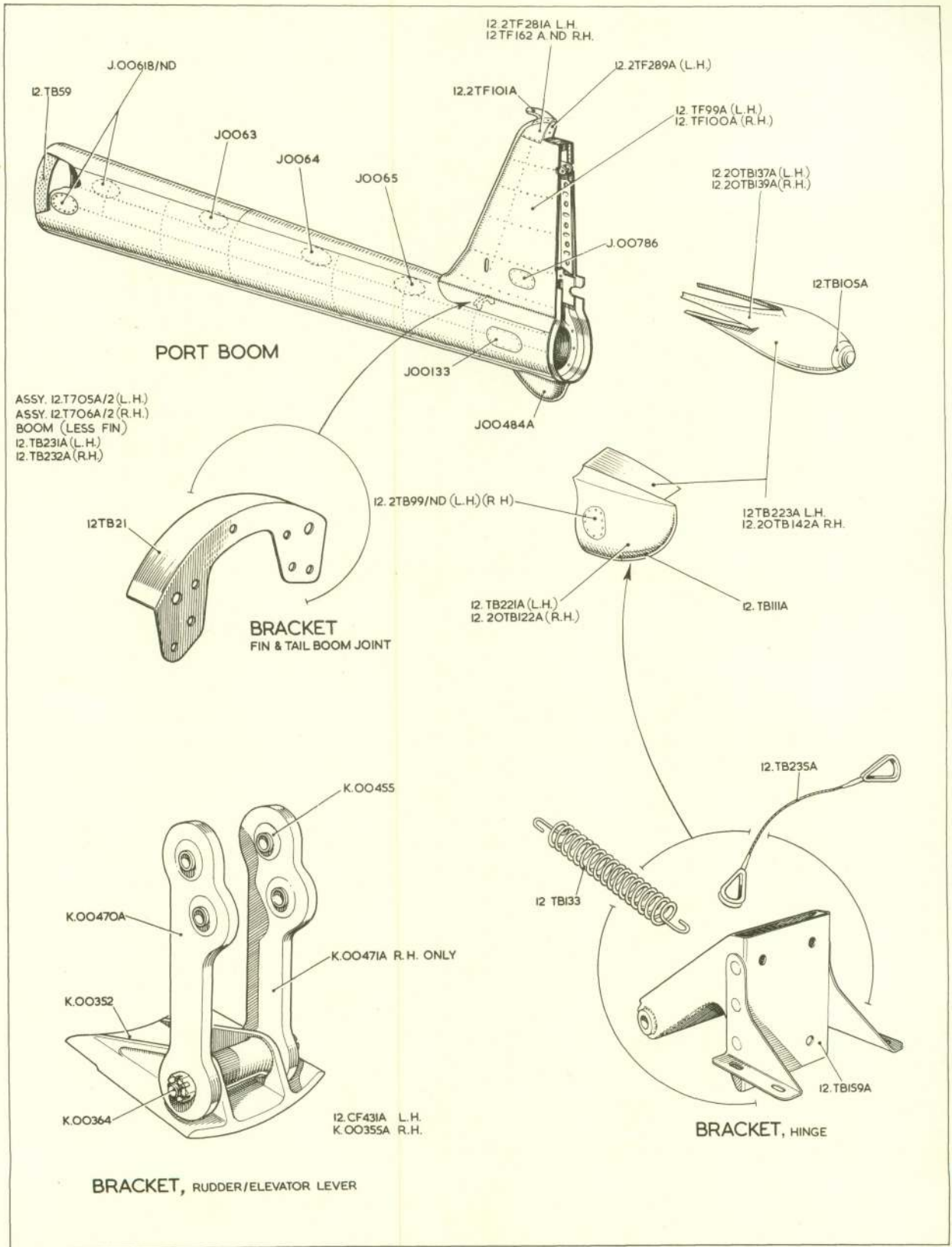

BE.I.

# AEROFOILS FIN AND BOOM

BE.I.

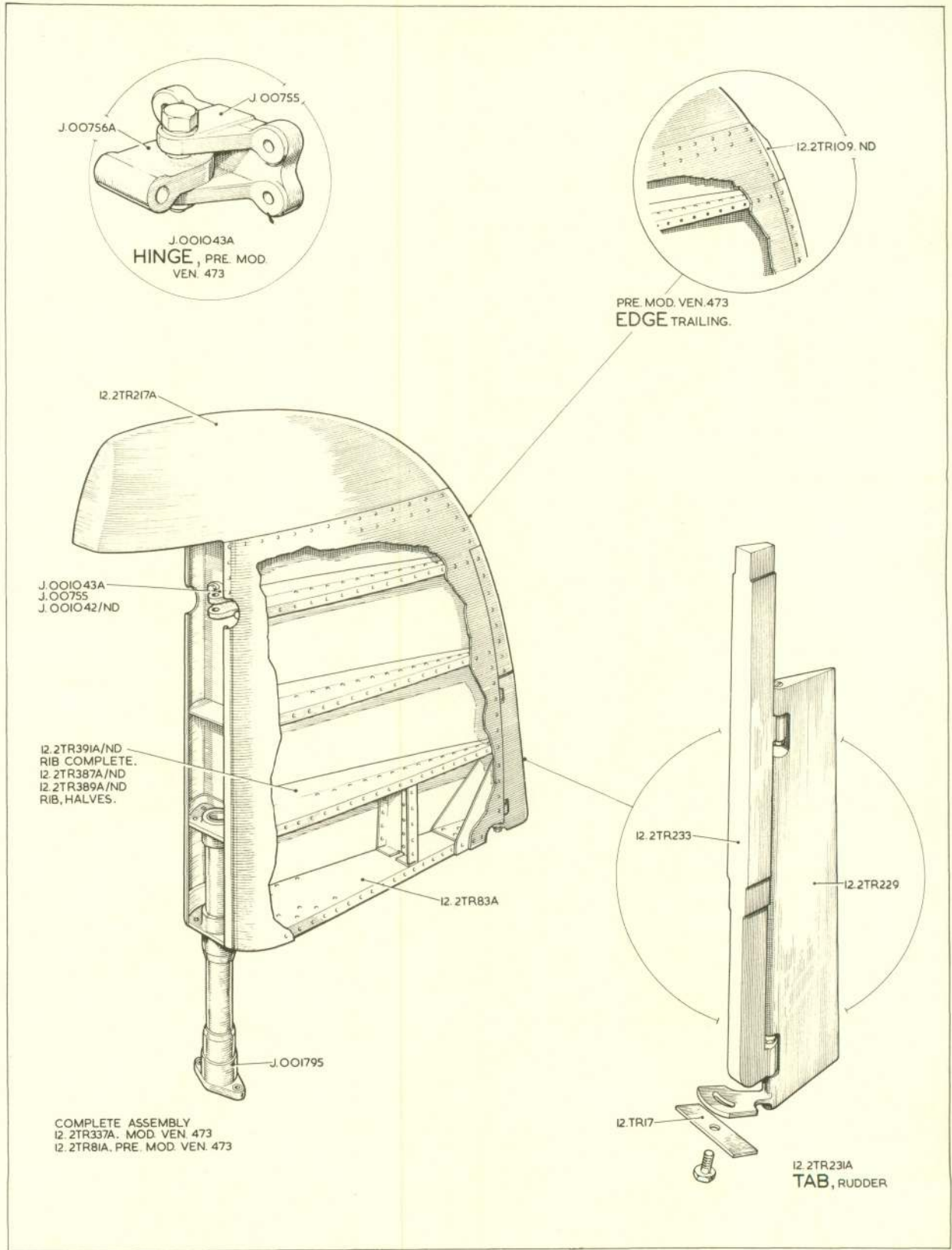

BF.1.

# AEROFOILS

BF.1.

## RUDDER

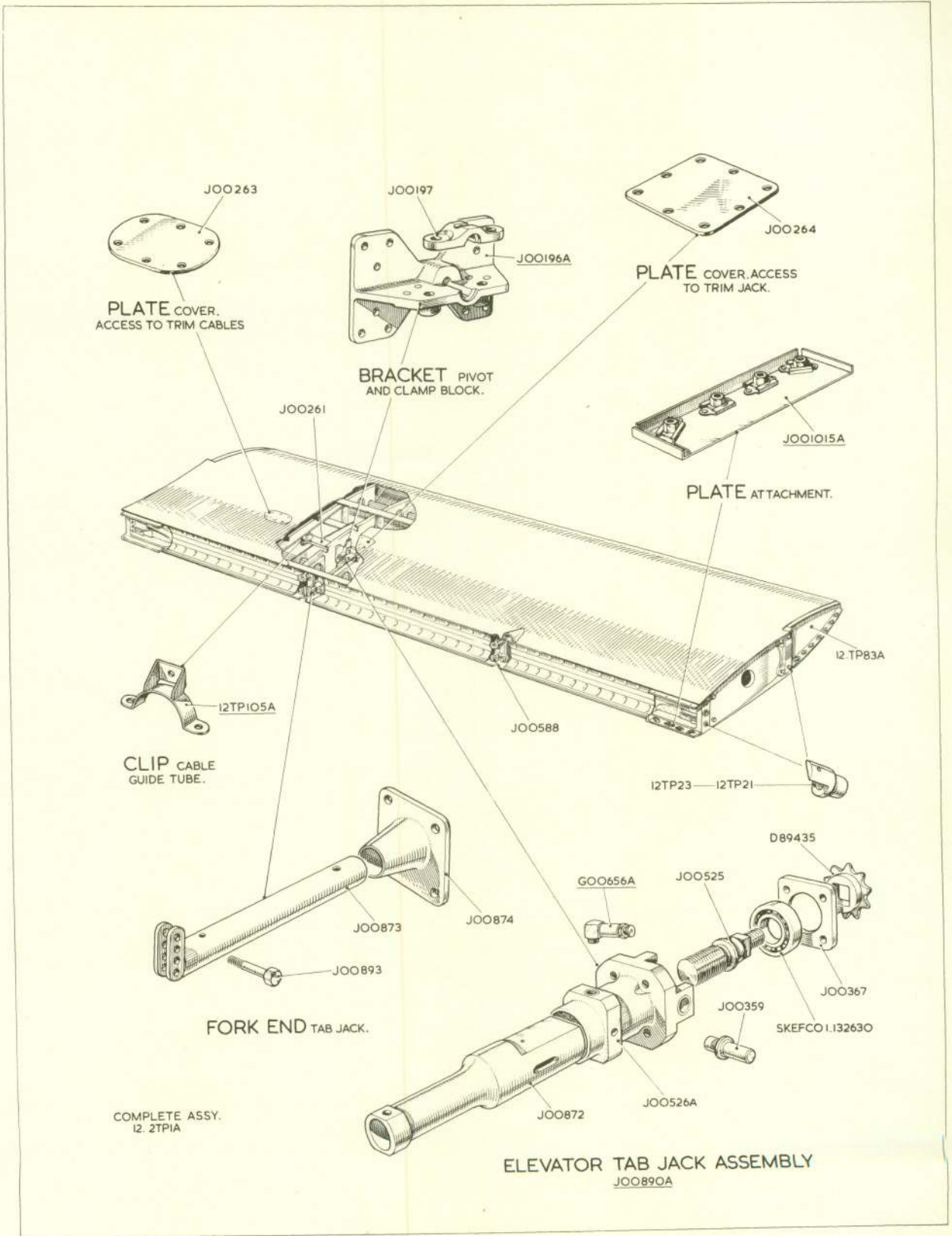

BG.1.

# AEROFOILS

BG.1.

## TAILPLANE

RESTRICTED

## HAND INK ALTERATIONS

Insert in the "Plate No." Column the following plate numbers against the undermentioned Part Numbers :—

## PAGE B.1

Ref. No.	Part No.	Plate No.	Ref. No.	Part No.	Plate No.
9773	12 WA 1159/A4	BA.1		12 W 3841A	B.2
9774	12 WA 1160/A3	BA.1		12 W 3842A	B.2
131	12 W 1351	B.2		12 W 3843A	B.2
132	12 W 1353	B.2		12 W 3844A	B.2
133	12 W 1939	B.2	5	12 WB 1A	B.3
28P/12462	SP.9/C8	B.2	6	12 WB 2A	B.3
28W/12324	SP.15/G	B.2	5866	12 WB 47A	B.3
752	12 W 1513	B.2	5867	12 WB 48A	B.3
753	12 W 1514	B.2	7142	12 WB 49ND	B.3
			7143	12 WB 50ND	B.3

## PAGE B.2

Ref. No.	Part No.	Plate No.	Ref. No.	Part No.	Plate No.
197	12 W 1009	B.3		12 WF 3A/1	B.4
198	12 W 1010	B.3		12 WF 4A/1	B.4
200	12 W 3089	B.3	214	12 WF 49	B.4
199	12 W 1011	B.3		12 WF 5A/1	B.4
9914	12 WF 89A/3	B.4		12 WF 6A/1	B.4
9915	12 WF 90A/3	B.4	213	12 WF 15	B.4
			215	12 WF 51	B.4

## PAGE B.3

Ref. No.	Part No.	Plate No.	Ref. No.	Part No.	Plate No.
5948	12 WF 193ND	B.4	529	12 S 473A/ND	B.2
5947	12 WF 194ND	B.4	536	12 S 501A/ND	B.2
211	12 WF 105	B.4	530	12 S 477A/ND	B.2
210	12 WF 103	B.4	537	12 S 505A/ND	B.2
212	12 W 2847	B.4	527	12 S 465A/ND	B.2
532	12 S 485A/ND	B.2	534	12 S 493A/ND	B.2
539	12 S 513A/ND	B.2	528	12 S 469A/ND	B.2
531	12 S 481A/ND	B.2	535	12 S 497A/ND	B.2
538	12 S 509A/ND	B.2	533	12 S 489A/ND	B.2
			540	12 S 517A/ND	B.2

## PAGE B.4

Ref. No.	Part No.	Plate No.	Ref. No.	Part No.	Plate No.
	12-4W 3A/20	B.1 & BB.1	1207	12-2W 125	B.2
	12-4W 4A/21	B.1 & BB.1	1204	12-2W 43	B.2
360	12 W 3025	B.2	1206	12-2W 139	B.2
			1205	12-2W 137	B.2

## PAGE BA.1

Ref. No.	Part No.	Plate No.	Ref. No.	Part No.	Plate No.
9773	12 WA 1159A/4	BA.1	5628	12 WA 121	BA.1
9774	12 WA 1160A/3	BA.1	6515	12 WA 1097	BA.1
3872	12 WA 13	BA.1	6514	12 WA 1095	BA.1
	12 WA 123	BA.1	160	12 WA 141ND	BA.1
4741	12 WA 801A	BA.1	161	12 WA 142ND	BA.1
	12 WA 803ND	BA.1	9771	12-4WA 25	BA.1
5899	12 WA 1015	BA.1	156	12 WA 9A	BA.1
3873	12 WA 15	BA.1	155	12 WA 5A	BA.1
			158	12 WA 31	BA.1

RESTRICTED

Issued with AL/2

PART 1

Venom FB Mk. 4

HAND INK ALTERATIONS

Insert in the " Plate No." Column the following plate numbers against the undermentioned Part Numbers :—

PAGE BA.2

Ref. No.	Part No.	Plate No.	Ref. No.	Part No.	Plate No.
9768	12-4CF 27A	BA.1	8510	12 WA 1209A	BA.1
9769	12-4 CF 17A	BA.1	8511	12 WA 1211	BA.1
9770	12-4 CF 21	BA.1		12 WA 1107	BA.1
4733	12 CF 943	BA.1	4637	15 FC 2053	BA.1
9777	12 WA 1085A/2	BA.1	6511	12 WA 1137A	BA.1
9778	12 WA 1086A/2	BA.1	6509	12 WA 1143	BA.1

PAGE BA.3

Ref. No.	Part No.	Plate No.	Ref. No.	Part No.	Plate No.
9772	12-4WA 29	BA.1		12 WA 1129A	BA.1
9162	12-4WA 33	BA.1		12 WA 991A	BA.1
9161	12-4WA 31	BA.1		12 WA 995	BA.1
				12 WA 997	BA.1

PAGE BB.1

Ref. No.	Part No.	Plate No.	Ref. No.	Part No.	Plate No.
	12-4W 3A/20	BB.1 & B.1		12 W 762A	BB.2
	12-4W 4A/21	BB.1 & B.1		12 W 763A	BB.3
7812	12 W 519	BB.1		12 W 764A	BB.3
7813	12 W 520	BB.1		12 W 765A	BB.3
	12 W 759A	BB.3		12 W 766A	BB.3
	12 W 760A	BB.3		12 W 459A	BB.3
	12W 761A	BB.2		12 W 460A	BB.3
				12 W 451A	BB.3

PAGE BB.2

Ref. No.	Part No.	Plate No.	Ref. No.	Part No.	Plate No.
	12 W 452A	BB.3		12 W 1246A	BB.3
	12 W 513A	BB.3		12 W 2143A	BB.3
	12 W 514A	BB.3		12 W 2144A	BB.3
	12 W 467A	BB.3	127	12 CF 65	BB.15
	12 W 468A	BB.3	2812	12 W 2603	BB.2
	12 W 497A	BB.3		12 W 2604	BB.2
	12 W 498A	BB.3	7877	12 W 3785	BB.2
	12 W 3629A/ND	BB.1	7878	12 W 3786	BB.2
	12 W 3630A/ND	BB.1		12 W 5471	BB.2
	12 W 1245A	BB.3		12 W 5472	BB.2
				12 M 303	BB.16

PAGE BB.3

Ref. No.	Part No.	Plate No.	Ref. No.	Part No.	Plate No.
	12 M 304	BB.16		12 N 66	BB.19
	12 M 301	BB.16		12 W 5269	BB.2
	12 M 302	BB.16	844	12 W 4023	BB.9
7721	12 M 157	BB.16		12 W 3257	BB.3
7722	12 M 158	BB.16		12 W 3259	BB.3
7875	12 W 3783	BB.2	3880	12 W 1063A	BB.8
7876	12 W 3784	BB.2		12 W 1067	BB.8
	12 W 1055	BB.5		12 W 1069	BB.8
6693	12 W 1057	BB.5	361	12 W 1071	BB.8
	12 N 65	BB.19			

## HAND INK ALTERATIONS

Insert in the "Plate No." Column the following plate numbers against the undermentioned Part Numbers :—

## PAGE BB.4

Ref. No.	Part No.	Plate No.	Ref. No.	Part No.	Plate No.
	12 W 1229	BB.14	7824	12 W 1874A	BB.9
3866	12 W 2165	BB.14	7825	12 W 1877A	BB.9
10137	12 CF 809A/1	BB.14	7826	12 W 1878A	BB.9
10138	12 CF 810A/1	BB.14	7841	12 W 2657A	BB.9
3859	12 W 1225	BB.14	7842	12 W 2658A	BB.9
3860	12 W 2249	BB.14	7843	12 W 2659A	BB.9
	N002619A	BB.16	7844	12 W 2660A	BB.9
7821	12 W 1869A	BB.9			
7822	12 W 1870A	BB.9			
7833	12 W 1873A	BB.9			

## PAGE BB.5

Ref. No.	Part No.	Plate No.	Ref. No.	Part No.	Plate No.
7852	12 W 2869A	BB.9		12 W 2985	BB.5
7853	12 W 2870A	BB.9		12 W 2986	BB.9
7845	12 W 2661A	BB.9		12 W 4911A	BB.1
7846	12 W 2662A	BB.9		12 W 4912A	BB.1
7855	12 W 2971	BB.9		12 W 2103	BB.16
7856	12 W 2972	BB.9		12 W 3805	BB.8
7857	12 W 2973	BB.9		12 W 3805	BB.8
7858	12 W 2974	BB.9		12 W 3806	BB.8
	12 W 2983	BB.9			
	12 W 2984	BB.9			

## PAGE BB.6

Ref. No.	Part No.	Plate No.	Ref. No.	Part No.	Plate No.
7871	12 W 3625	BB.6	374	12 W 3679	BB.6
7872	12 W 3626	BB.6	375	12 W 3680	BB.6
7136	12 W 1271	BB.6	8817	12 W 5623	BB.10
7820	12 W 1272	BB.6		12 W 5619ND	BB.10
	12 W 4381A	BB.8	8820	12 W 5621ND	BB.10
	12 W 4382A	BB.8	8818	12 W 5625	BB.10

## PAGE BB.7

Ref. No.	Part No.	Plate No.	Ref. No.	Part No.	Plate No.
295	12 W 189	BB.10	296	12 W 190	BB.10
373	12 W 3627	BB.6	372	12 W 3493	BB.6
371	12 W 1727	BB.6		12 W 4317A	BB.10
	12 W 3239	BB.16	4837	12 N 1285A	BB.16
	12 U 355	BB.16		12 W 4915	BB.14
	12 W 4916	BB.14	7840	12 W 2653A	BB.12
7854	12 W 2961A	BB.12	9316	12 W 4815A	BB.12
3893	12 W 2299A	BB.8	3894	12 W 2300A	BB.8
308	12 W 3515A/ND	BB.8	309	12 W 3516A/ND	BB.8
28R/13491	AS.107	BB.8			

## PAGE BB.8

Ref. No.	Part No.	Plate No.	Ref. No.	Part No.	Plate No.
3895	12 W 3097A	BB.8		12 W 5021A	BB.8
3896	12 W 3098A	BB.8		12 W 5022A	BB.5
310	12 W 3517A/ND	BB.8	7135	12 W 421	BB.16
311	12 W 3518A/ND	BB.8	7293	12 W 423	BB.16
362	12 W 109A	BB.6		12 W 2667	BB.3
2197	12 W 1325	BB.6		12 W 2668	BB.3
2198	12 W 1326	BB.8			

RESTRICTED

Issued with AL/2

PART 1

Venom FB Mk. 4

HAND INK ALTERATIONS

Insert in the "Plate No." Column the following plate numbers against the undermentioned Part Numbers :—

PAGE BB.9

Ref. No.	Part No.	Plate No.	Ref. No.	Part No.	Plate No.
	12 W 3597	BB.2		12 W 170	BB.15
	12 W 3598	BB.2		12 CF 845A	BB.13
	12 W 169	BB.15		12 CF 881A	BB.13

PAGE BB.10

Ref. No.	Part No.	Plate No.	Ref. No.	Part No.	Plate No.
	12 CF 851	BB.13	4717	12 CF 973A	BB.13
4716	12 CF 971A	BB.13	1305	12 M 59A/1	BB.8
1306	12 W 4313	BB.8	1919	12-20 M 23A	BB.8
1921	12-2M 191	BB.8	329	12 W 2389A	BB.8
4709	12 CF 831A	BB.13	4710	12 CF 832A	BB.13
4711	12 CF 817	BB.13		12 W 2975	BB.9
	12 W 2976	BB.9		12 W 3435	BB.9
	12 W 3436	BB.9			

PAGE BB.11

Ref. No.	Part No.	Plate No.	Ref. No.	Part No.	Plate No.
	12 W 2617ND	BB.12		12 W 2623ND	BB.12
	12 W 2618ND	BB.12		12 W 2624ND	BB.12
	12 W 2619ND	BB.12		12 W 2625ND	BB.12
	12 W 2620ND	BB.12		12 W 2626ND	BB.12
	12 W 2621ND	BB.12		12 W 2627ND	BB.12
	12 W 2622ND	BB.12		12 W 2628ND	BB.12
	12 W 2629ND	BB.12		12 W 2630ND	BB.12
	12 W 2631ND	BB.12			

PAGE BB.12

Ref. No.	Part No.	Plate No.	Ref. No.	Part No.	Plate No.
	12 W 2632ND	BB.12		12 W 2663A	BB.9
	12 W 2633ND	BB.12		12 W 3433	BB.9
	12 W 2634ND	BB.12		12 W 3434	BB.9
	12 W 2635ND	BB.12		12 W 2665A	BB.9
	12 W 2636ND	BB.12		12 W 1321	BB.7
				12 W 1322	BB.7

PAGE BB.13

Ref. No.	Part No.	Plate No.	Ref. No.	Part No.	Plate No.
	12 W 1361	BB.7		12 W 3636	BB.9
	12 W 1362	BB.7	6583	12 S 1409	BB.15
	12 W 1359	BB.7		12 S 1629	BB.15
	12 W 1360	BB.7	792	12 A 97A	BB.15
	12 W 2955ND	BB.12	349	12 W 3591A	BB.10
	12 W 3635	BB.13		12 N 63ND	BB.19

PAGE BB.14

Ref. No.	Part No.	Plate No.	Ref. No.	Part No.	Plate No.
	12 N 59ND	BB.19		12 N 49ND	BB.19
	12 N 1371	BB.19		12 N 45ND	BB.19
207	12 W 3387A	BB.11		12 N 43ND	BB.19
	12 N 55A/ND	BB.19		12 W 4879A	BB.19
	12 W 2295ND	BB.19		12 W 4880A	BB.19
	12 N 47ND	BB.19		12 W 5063A/ND	BB.19
	12 N 989ND	BB.19		12 W 5064A/ND	BB.19
				12 W 5457A/ND	BB.19

## HAND INK ALTERATIONS

Insert in the "Plate No." Column the following plate numbers against the undermentioned Part Numbers :—

## PAGE BB.15

Ref. No.	Part No.	Plate No.	Ref. No.	Part No.	Plate No.
	12 W 5458A/ND	BB.19		12 W 5065A/ND	BB.19
	12 W 5131ND	BB.19		12 W 5066A/ND	BB.19
	12 W 5132ND	BB.19		12 W 5097ND	BB.19
	12 W 5453ND	BB.19		12 W 5098ND	BB.19
	12 W 5454ND	BB.19		12 W 3659A/ND	BB.19
	12 W 3795A/ND	BB.19		12 W 3660A/ND	BB.19
	12 W 3796A/ND	BB.19		12 W 1783ND	BB.19
	12 W 5461A/ND	BB.19		12 W 1773ND	BB.19
	12 W 5462A/ND	BB.19		R 98356	BB.15
	12 W 5297ND	BB.19		12 W 527A	BB.1
	12 W 5463ND	BB.19		12 W 528A	BB.1

## PAGE BB.16

Ref. No.	Part No.	Plate No.	Ref. No.	Part No.	Plate No.
	12 W 523A	BB.1		12 W 2079	BB.7
	12 W 524A	BB.1		12 W 2080	BB.7
6694	12 W 1311A	BB.7		12 W 5089A	BB.2
6695	12 W 1312A	BB.7		12 W 5090A	BB.2
	12 W 4931A/ND	BB.7		12 W 399A	BB.2
	12 W 3929A/ND	BB.7		12 W 400A	BB.2
	12 W 1307A	BB.7		12 W 401	BB.2
	12 W 1308A	BB.7		12 W 402	BB.2
	12 W 4193ND	BB.7	6212	12 W 3579A	BB.3
	12 W 2081	BB.7	6213	12 W 3580A	BB.3
	12 W 2082	BB.7		12 W 3577A	BB.3
			6211	12 W 3578A	BB.3

## PAGE BB.17

Ref. No.	Part No.	Plate No.	Ref. No.	Part No.	Plate No.
1137	12 W 4279	BB.1	6061	12 PT 1725A	BB.17
1138	12 W 4280	BB.1	7270	12 P 1144A	BB.11
885	12 W 4137A	BB.17	7269	12 P 1143A	BB.11
2356	12 W 2765A/1	BB.17	8743	12 W 5691	BB.11
2944	12 W 2766A/1	BB.17	6598	12 W 1157A/3	BB.1
8514	12 W 2817	BB.17	6599	12 W 1158A/3	BB.1
			9317	12 W 5387A/ND	BB.1

## PAGE BB.18

Ref. No.	Part No.	Plate No.	Ref. No.	Part No.	Plate No.
5896	12 A 557A	BB.15	8788	12 W 4841A/ND	BB.7
7879	12 W 3803	BB.8	8789	12 W 4842A/ND	BB.7
7865	12 W 3041A	BB.12		12 W 719	BB.7
7866	12 W 3042A	BB.12		12 W 717	BB.7
5856	12 W 3033A	BB.12	699	12 W 3881A	BB.7
5857	12 W 3034A	BB.12	700	12 W 3882A	BB.7
340	12 W 3719A	BB.8	930	12 W 3827A/ND	BB.7
341	12 W 3720A	BB.8	931	12 W 3828A/ND	BB.7
	12 W 4401A/3	BB.7	928	12 W 669A/ND	BB.7
	12 W 4402A/3	BB.7	929	12 W 670A/ND	BB.7

RESTRICTED

Issued with AL/2

PART 1

Venom FB Mk. 4

HAND INK ALTERATIONS

Insert in the "Plate No." Column the following plate numbers against the undermentioned Part Numbers :-

PAGE BB.19

Ref. No.	Part No.	Plate No.	Ref. No.	Part No.	Plate No.
	12-2W 185A	BB.7	825	12 W 3943	BB.15
	12-2W 186A	BB.7	824	12 W 3941	BB.15
	12 W 679A	BB.7	344	12 W 3301	BB.7
	12 W 680A	BB.7	345	12 W 3302	BB.7
	12-2W 193A	BB.7		12 M 155	BB.8
	12-2W 194A	BB.7		12 CF 961	BB.14
	12 W 677A	BB.7		12 CF 963	BB.14
	12 W 678A	BB.7			

PAGE BB.20

Ref. No.	Part No.	Plate No.	Ref. No.	Part No.	Plate No.
	12 W 2831	BB.9		12 W 2931	BB.12
	12 W 2839	BB.9		12 W 2933	BB.12
	12 W 2835	BB.9		12 W 2935	BB.12
	12 CF 595	BB.15		12 W 2937	BB.12
	12 CF 597	BB.15		12 W 2939	BB.12
	12 CF 599	BB.15		12 W 3103	BB.12
	12 W 1065	BB.3		12 W 3105	BB.12
	12 W 1066	BB.3		12 W 3107	BB.12
	12 W 2859	BB.9	9371	12 W 3111	BB.12

PAGE BB.21

Ref. No.	Part No.	Plate No.	Ref. No.	Part No.	Plate No.
276	12 W 1829	BB.1	205	12 W 3215	BB.11
3883	12 W 171	BB.15		12 W 4587ND	BB.11
3884	12 W 172	BB.15	220	12 W 2851	BB.10
26FC/201	D.00714	BB.15	26FC/28	D.001769	BB.10
26FC/354	D.00827	BB.15		12 CF 71A	BB.15
204	12 W 3191	BB.11		12 CF 72A	BB.15
			956	12 W 4161	BB.15

PAGE BB.22

Ref. No.	Part No.	Plate No.	Ref. No.	Part No.	Plate No.
367	12 W 181	BB.6	365	12 W 179	BB.6
368	12 W 183	BB.6	336	12 W 180	BB.6
369	12 W 185	BB.6	27M/608	AIR.41474	BB.11
370	12 W 187	BB.6	206	12 W 3265	BB.11
363	12 W 177	BB.6	27M/647	AIR.42208	BB.10
664	12 W 178	BB.6	26FC/30	G.0050	BB.10
			26FC/260	D.001772	BB.10

PAGE BB.23

Ref. No.	Part No.	Plate No.	Ref. No.	Part No.	Plate No.
	12 W 3709A	BB.8		12 W 3711ND	BB.8
	12 W 3708A	BB.8	4701	12 CF 853A	BB.13
5CX/492	†	BB.8	4702	12 CF 855	BB.13
5CX/496	†	BB.8	4703	12 CF 859	BB.13
				12 W 4077A/ND	BB.8

## HAND INK ALTERATIONS

Insert in the "Plate No." Column the following plate numbers against the undermentioned Part Numbers :—

## PAGE BB.24

Ref. No.	Part No.	Plate No.	Ref. No.	Part No.	Plate No.
7880	12 W 3807A	BB.8	4706	12 CF 819	BB.13
7881	12 W 3808A	BB.8	6495	12 CF 861A	BB.13
4705	12 CF 925A/ND	BB.13		12 CF 865	BB.13
4704	12 CF 926A/ND	BB.13	9616	12-4CF 45A	BB.14
6493	12 CF 841A	BB.13	9617	12-4CF 46A	BB.14
6494	12 CF 842A	BB.13		12 CF 1029	BB.13
	12 CF 1029	BB.14	4726	12 CF 567	BB.14
6492	12 CF 839	BB.13		12 W 4867	BB.10
				12 W 4869	BB.10

## PAGE BB.25

Ref. No.	Part No.	Plate No.	Ref. No.	Part No.	Plate No.
221	12 WF 109A/ND	BB.10	26FC/2969	D.003166	BB.15
216	12 WF 11A	BB.10	26FC/2967	D.003167	BB.15
217	12 WF 12A	BB.10	26FC/353	D.002299	BB.15
218	12 WF 33	BB.10	8865	12 W 291A/2	BB.2
	12 W 2087	BB.16	8866	12 W 292A/2	BB.2
			7831	12 W 2088	BB.16

## PAGE BB.26

Ref. No.	Part No.	Plate No.	Ref. No.	Part No.	Plate No.
7829	12 W 2085	BB.16		12 W 3055A	BB.20
7830	12 W 2086	BB.16		12 W 3056A	BB.20
	12 W 5081A	BB.20		12 W 3057A	BB.12
	12 W 5082A	BB.20		12 W 3058A	BB.12
4738	12 W 4955A	BB.5	4736	12 W 5017A/ND	BB.5
4739	12 W 4956A	BB.5	4737	12 W 5018A/ND	BB.5
	12 W 5167A	BB.5	4734	12 W 4991A/ND	BB.5
	12 W 5168A	BB.5	4735	12 W 4992A/ND	BB.5

## PAGE BB.27

Ref. No.	Part No.	Plate No.	Ref. No.	Part No.	Plate No.
3882	12-2W 319	BB.4		12 W 5290A	BB.5
3881	12-2W 321	BB.4		12 W 5283A	BB.5
313	12 W 1431	BB.4		12 W 5284A	BB.5
314	12 W 2695	BB.4	7884	12 W 4025A	BB.9
790	12 A 55A/ND	BB.15	7885	12 W 4026A	BB.9
704	12 W 3395A/ND	BB.11		12 W 1885A	BB.9
705	12 W 3396A/ND	BB.11		12 W 1886A	BB.9
1926	12 S 1061A	BB.1	2958	12 PT 1437	BB.1
2852	12 W 4631A	BB.1		12 W 2029ND	BB.1
	12 W 5289A	BB.5			

## PAGE BB.28

Ref. No.	Part No.	Plate No.	Ref. No.	Part No.	Plate No.
148	12 W 1846A	BB.5	271	12 W 3219	BB.17
147	12 W 1845A	BB.5	267	12 W 3201	BB.17
151	12 W 1930A	BB.5	268	12 W 3203	BB.17
150	12 W 1929A	BB.5	272	12 W 3497	BB.17
2957	12 W 4859	BB.1	269	12 W 3205	BB.17
2959	12 W 4863	BB.1	270	12 W 3217	BB.17
1931	12 W 4385A	BB.18	1290	12 W 4263	BB.17
1932	12 W 4386A	BB.18	266	12 W 3199	BB.17

RESTRICTED

Issued with AL/2

PART 1

Venom FB Mk.4

HAND INK ALTERATIONS

Insert in the "Plate No." Column the following plate numbers against the undermentioned Part Numbers :-

PAGE BB.29

Ref. No.	Part No.	Plate No.	Ref. No.	Part No.	Plate No.
265	12 W 2061	BB.17	290	12 W 3249	BB.17
273	12 W 3781	BB.17	1289	12 W 4289	BB.17
274	12 W 3782	BB.17	1490	12 W 4290	BB.17
	12 W 1841ND	BB.1	288	12 W 3247	BB.17
293	12 W 3321	BB.17	289	12 W 3248	BB.17
			292	12 W 3253	BB.17

PAGE BB.30

Ref. No.	Part No.	Plate No.	Ref. No.	Part No.	Plate No.
877	12 W 4149	BB.17		12 W 2076ND	BB.7
7883	12 W 3997	BB.5		12 W 2267A	BB.16
	12 W 4967	BB.5		12 W 2913A	BB.16
	12 W 2083	BB.7		12 W 2914A	BB.16
	12 W 2071ND	BB.7		12 W 2909A	BB.16
	12 W 2072ND	BB.7		12 W 2917A	BB.16
	12 W 2075ND	BB.7		12 W 2918A	BB.16

PAGE BB.31

Ref. No.	Part No.	Plate No.	Ref. No.	Part No.	Plate No.
	12 W 1005	BB.2			

PAGE BB.33

Ref. No.	Part No.	Plate No.	Ref. No.	Part No.	Plate No.
3948	12 W 191A	BB.10	1356	12-2W 128	BB.4
3949	12 W 192A	BB.10	254	12 W 105	BB.4
	12 W 2263A	BB.16	1477	12 W 4249	BB.4
1353	12-2W 105	BB.4	125	12 CF 63A	BB.15
1354	12-2W 106	BB.4	126	12 CF 64A	BB.15
252	12 W 101	BB.4	27S/143	I.132499	BB.15
842	12 W 4019	BB.4	26FC/24	D.00348	BB.15
843	12 W 4021	BB.4	7814	12 W 521	BB.8
1355	12-2W 127	BB.4	7815	12 W 522	BB.8

PAGE BB.34

Ref. No.	Part No.	Plate No.	Ref. No.	Part No.	Plate No.
	12 W 4945A	BB.5		12 W 1917A	BB.5
	12 W 4946A	BB.5		12 W 461	BB.3
	12 W 4939	BB.5		12 W 462	BB.3
	12 W 4940	BB.5		12 W 463	BB.3
330	12 W 3713A	BB.8		12 W 464	BB.3
	12 W 3714A	BB.8		12 W 453	BB.3
6015	12 W 5147	BB.2		12 W 454	BB.3
5604	12 W 4275A	BB.2		12 W 455	BB.3
5605	12 W 4276A	BB.2		12 W 456	BB.3
	12 W 3967A	BB.5		12 W 327	BB.3
	12 W 3968A	BB.5		12 W 328	BB.3
835	12 W 3963	BB.5		12 W 1017	BB.3
	12 W 3971A	BB.5		12 W 1018	BB.3
	12 W 3972A	BB.5		12 W 881	BB.3
836	12 W 3977	BB.5		12 W 882	BB.3

HAND INK ALTERATIONS

Insert in the "Plate No." Column the following plate numbers against the undermentioned Part Numbers :—

PAGE BB.35

Ref. No.	Part No.	Plate No.	Ref. No.	Part No.	Plate No.
	12 W 319A/1	BB.3		12 W 2990	BB.3
	12 W 320A/1	BB.3		12 W 1371	BB.15
	12 W 547	BB.3		12 W 1372	BB.15
	12 W 548	BB.3		12 W 325A	BB.3
	12 W 2991	BB.3		12 W 326A	BB.3
	12 W 2992	BB.3		12 W 1099	BB.3
	12 W 543	BB.3		12 W 1100	BB.3
	12 W 544	BB.3		12 W 1097	BB.3
	12 W 2989	BB.3		12 W 1098	BB.3

PAGE BB.36

Ref. No.	Part No.	Plate No.	Ref. No.	Part No.	Plate No.
	12 W 2999	BB.3		12 W 2996	BB.3
	12 W 3000	BB.3		12 W 447A	BB.2
	12 W 2997	BB.3		12 W 337A	BB.2
	12 W 2998	BB.3		12 W 338A	BB.2
	12 W 883A	BB.2		12 W 5483A	BB.4
	12 W 884A	BB.2		12 W 5484A	BB.4
	12 W 2993	BB.3	1963	12 EC 827	BB.4
	12 W 2994	BB.3		12 W 3401	BB.4
	12 W 2995	BB.3		12 W 3402	BB.4

PAGE BB.37

Ref. No.	Part No.	Plate No.	Ref. No.	Part No.	Plate No.
	12 W 3403	BB.4		12 EC 965ND	BB.4
	12 W 3404	BB.4		12 EC 967ND	BB.4
4854	12 W 3491	BB.4		12 EC 968ND	BB.4
4855	12 W 3492	BB.4		12 W 267	BB.9
	12 EC 1243A/ND	BB.4		12 W 268	BB.9
	12 EC 1244A/ND	BB.4	382	12 EC 111	BB.4
2886	12 EC 1051	BB.4	383	12 EC 112	BB.4
			386	12 EC 347A	BB.4

PAGE BB.38

Ref. No.	Part No.	Plate No.	Ref. No.	Part No.	Plate No.
387	12 EC 348A	BB.4		12 W 119	BB.4
378	12 EC 97A	BB.4		12 W 120	BB.4
379	12 EC 98A	BB.4		12 W 21	BB.4
1961	12 EC 825	BB.4		12 W 22	BB.4
1962	12 EC 826	BB.4	380	12 EC 99A	BB.4
			381	12 EC 100A	BB.4

PAGE BB.39

Ref. No.	Part No.	Plate No.	Ref. No.	Part No.	Plate No.
	12 W 3437A	BB.4		12 W 3731A	BB.2
	12 W 3637A	BB.4		12 W 3743A	BB.2
	12 W 3503	BB.4		12 W 4209	BB.2
	12 W 3504	BB.4		12 W 4210	BB.2
5643	12 EC 1077A	BB.4 & BB.16	2341	12 W 873A	BB.3
	12 W 35A	BB.4		12 W 874A	BB.3
	12 W 36A	BB.4		12 W 4415A	BB.3
	12 W 2709	BB.4		12 W 4416A	BB.3
	12 W 2710	BB.4		12 W 4417	BB.3
	12-2 W 317	BB.4		12 W 4418	BB.3
	12-2 W 318	BB.4		12 W 4419	BB.3
				12 W 4420	BB.3

RESTRICTED

PART 1

Venom FB Mk. 4

Issued with AL/2

HAND INK ALTERATIONS

Insert in the "Plate No." Column the following plate numbers against the undermentioned Part Numbers :-

PAGE BB.40

Ref. No.	Part No.	Plate No.	Ref. No.	Part No.	Plate No.
	12 W 355A	BB.3		12 W 1770	BB.16
	12 W 356A	BB.3		12 W 1767	BB.16
	12 W 1763	BB.16		12 W 1768	BB.16
	12 W 1765	BB.16		12 W 2413	BB.6
	12 W 1766	BB.16		12 W 2414	BB.6
	12 W 1769	BB.16		12 W 2415	BB.6
				12 W 2416	BB.6

PAGE BB.41

Ref. No.	Part No.	Plate No.	Ref. No.	Part No.	Plate No.
312	12 W 2419	BB.6		12 W 1135A	BB.2
	12 W 1945A/1	BB.3		12 W 1136A	BB.2
	12 W 1946A/1	BB.3		12 W 1093A	BB.2
	12 W 1335A/1	BB.3		12 W 1094A	BB.2
	12 W 1336A/1	BB.3		12 W 1079A	BB.2
258	12 W 1643	BB.6		12 W 1080A	BB.2
259	12 W 1644	BB.6		12 W 3031A	BB.2
260	12 W 1645	BB.6		12 W 3032A	BB.2
261	12 W 1646	BB.6		12 W 4285	BB.2
	12 W 297A	BB.3	393	12 W 2365	BB.1
	12 W 298A	BB.3	4714	12 CF 821A	BB.14
	12-3W 77	BB.3		12 CF 823	BB.14
	12-3W 78	BB.3	4715	12 CF 827A	BB.14
	12 W 1153A	BB.2		12 W 1075A	BB.2
	12 W 1154A	BB.2		12 W 1076A	BB.2

PAGE BB.42

Ref. No.	Part No.	Plate No.	Ref. No.	Part No.	Plate No.
4712	12 CF 835A	BB.13	26FC/2145	L.001251	BB.11
4713	12 CF 815	BB.13	2931	12 P 539ND	BB.11
	12 CF 837	BB.13	2932	12 P 899ND	BB.11
	12 P 1035A/ND	BB.11	2933	12 P 537ND	BB.11
	12 P 1037A/ND	BB.11	26FC/2146	L.001250	BB.11
	12 P 1039A/ND	BB.11		12 W 2717A	BB.20
26FC/2142	L.001249	BB.11		12 W 2718A	BB.20
26FC/2143	L.001252	BB.11		12 W 2711A	BB.20
26FC/2144	L.001253	BB.11		12 W 2712A	BB.20
26FC/2131	L.001248	BB.11		12 W 3027A	BB.20

PAGE BB.43

Ref. No.	Part No.	Plate No.	Ref. No.	Part No.	Plate No.
	12 W 3028A	BB.20		12 W 2092	BB.20
	12 W 2023	BB.20		12 W 5071A/ND	BB.20
	12 W 2024	BB.20		12 W 5072A/ND	BB.20
	12 W 2021	BB.20		12 W 3113A	BB.20
	12 W 2022	BB.20		12 W 3114A	BB.20
	12 W 2089	BB.20		12 W 2063	BB.20
	12 W 2090	BB.20		12 W 2064	BB.20
	12 W 2091	BB.20		12 W 2065	BB.20
				12 W 2066	BB.20

## HAND INK ALTERATIONS

Insert in the "Plate No." Column the following plate numbers against the undermentioned Part Numbers :—

## PAGE BB.44

Ref. No.	Part No.	Plate No.	Ref. No.	Part No.	Plate No.
	12 W 3547	BB.20		12 W 5434A/ND	BB.20
	12 W 3548	BB.20		12 W 2689A/ND	BB.20
	12 W 2341	BB.20		12 W 2690A/ND	BB.20
	12 W 2342	BB.20		12 W 2453A/ND	BB.20
	12 W 2541	BB.20		12 W 2454A/ND	BB.20
	12 W 2542	BB.20		12 W 2471A/ND	BB.20
	12 W 2539	BB.20		12 W 2472A/ND	BB.20
	12 W 2540	BB.20		12 W 1591A/ND	BB.20
	12 W 2515	BB.20		12 W 1592A/ND	BB.20
	12 W 2516	BB.20	1139	12 W 4217A/ND	BB.20
	12 W 5433A/ND	BB.20	1140	12 W 4218A/ND	BB.20

## PAGE BB.45

Ref. No.	Part No.	Plate No.	Ref. No.	Part No.	Plate No.
	12 W 1609A/ND	BB.20		12 W 1535A/ND	BB.20
	12 W 1610A/ND	BB.20		12 W 1536A/ND	BB.20
	12 W 1617A/ND	BB.20	7137	12 W 2107A	BB.7
	12 W 1618A/ND	BB.20	26FC/1989	D.002477	BB.7
	12 W 1519A/ND	BB.20	26FC/1990	D.002478A	BB.7
	12 W 1520A/ND	BB.20	6442	12 W 2108A	BB.7
	12 W 1527A/ND	BB.20		12 W 2093A	BB.7
	12 W 1528A/ND	BB.20		12 W 2094A	BB.1
	12 W 1531A/ND	BB.20	346	12 W 3767A/ND	BB.1
	12 W 1532A/ND	BB.20	701	12 W 3768A/ND	BB.1

## PAGE BB.46

Ref. No.	Part No.	Plate No.	Ref. No.	Part No.	Plate No.
	12-3W 179A	BB.2		12-3W 184	BB.2
	12-3W 180A	BB.2	10338	12 W 5395A/2	BB.1
	12-3W 247A/ND	BB.3	10339	12 W 5396A/2	BB.1
	12-3W 183	BB.2	10334	12 W 131A/3	BB.1
			10335	12 W 132A/2	BB.1

## PAGE BB.47

Ref. No.	Part No.	Plate No.	Ref. No.	Part No.	Plate No.
2195	12 W 153	BB.2		12 W 2888ND	BB.18
10112	12-3W 219/1	BB.2		12 W 2185ND	BB.18
10113	12-3W 220/1	BB.2		12 W 2186ND	BB.18
	12-3W 243A/ND	BB.2		12 W 2197ND	BB.18
	12-3W 244A/ND	BB.2		12 W 2198ND	BB.18
7834	12 W 2181ND	BB.18		12 W 2199ND	BB.18
7835	12 W 2182ND	BB.18		12 W 2200ND	BB.18
	12 W 5575ND	BB.18		12 W 5423ND	BB.18
	12 W 5576ND	BB.18		12 W 5424ND	BB.18
	12 W 2187ND	BB.18		12 W 3801ND	BB.18
	12 W 2188ND	BB.18		12 W 3802ND	BB.18
	12 W 2887ND	BB.18		12 W 3551ND	BB.18
				12 W 3552ND	BB.18

## PAGE BB.48

Ref. No.	Part No.	Plate No.	Ref. No.	Part No.	Plate No.
4727	12 CF 965	BB.14	306	12 M 115	BB.8
	12 W 4083ND	BB.8	5733	12 W 305A	BB.8
307	12 M 117	BB.8		12 W 306A	BB.8
328	12 W 3815	BB.8	4723	12 CF 969ND	BB.13
			4722	12 CF 967ND	BB.13

RESTRICTED

Issued with AL/2

PART 1

Venom FB Mk.4

HAND INK ALTERATIONS

Insert in the "Plate No." Column the following plate numbers against the undermentioned Part Numbers :—

PAGE BB.49

Ref. No.	Part No.	Plate No.	Ref. No.	Part No.	Plate No.
338	12 W 1859A	BB.8		12 W 4288	BB.18
	12 W 1851	BB.8	285	12 W 2889	BB.1
	12 W 1855	BB.8	6A/2133	132 FL-SMITH	BB.10
1894	12 W 4551	BB.8	202	12 W 211A	BB.11
1472	12 W 4239	BB.8	201	12 W 209	BB.11
6697	12 W 4287	BB.18	203	12 W 219	BB.11

PAGE BB.50

Ref. No.	Part No.	Plate No.	Ref. No.	Part No.	Plate No.
	12 W 4517A	BB.12		12 WF 37	BB.10
	12 W 4518A	BB.12		12 WF 29	BB.10
	12 W 4219A	BB.12		12 WF 30	BB.10
	12 W 4220A	BB.12		12 WF 31	BB.10
2199	12 WF 93A/ND	BB.10	27V/4118	FKG/A/30	BB.11
2200	12 WF 94A/ND	BB.10	27F/2270	HG/100/H10	BB.11
	12 WF 35	BB.10	27F/2270	810/BAO1	BB.11

PAGE BB.51

Ref. No.	Part No.	Plate No.	Ref. No.	Part No.	Plate No.
	12 W 1655A/2	BB.6		12 W 1691A/3	BB.6
	12 W 1656A/2	BB.6		12 W 1692A/3	BB.6
827	12 W 1683ND	BB.6			

PAGE BC.1

Ref. No.	Part No.	Plate No.	Ref. No.	Part No.	Plate No.
	12-4T 1	BC.1	935	12 T 205	BC.1
1184	12 T 287	BC.1	26FC/2538	J.00460A	BC.1
1179	12 T 288	BC.1	26FC/2537	J.00459A	BC.1
1186	12 T 225	BC.1	26FC/8038	J.00984	BC.1
1185	12 T 285	BC.1	9349	12-4TE 1A/1	BC.1
1180	12 T 286	BC.1	7688	12 TE 781A	BC.1
8189	12 T 513A	BC.1	8190	12 T 514A	BC.1

PAGE BC.2

Ref. No.	Part No.	Plate No.	Ref. No.	Part No.	Plate No.
	12-2 TP1A	BC.1	8841	12-20TB137A	BE.1
	12 TB 159A	BE.1	2565	12-2TB 105	BE.1
	12 TB 235A	BE.1		12-TB 221A	BE.1
9369	12-TB 223A	BE.1	5099	12-2TB99ND	BE.1

PAGE BC.3

Ref. No.	Part No.	Plate No.	Ref. No.	Part No.	Plate No.
8842	12-20TB 142A	BE.1		12-20TB 139A	BE.1
	12-20TB 122A	BE.1	5099	12-2TB 99ND	BE.1
2908	12 TB 133	BE.1	8829	12 T 705A/2	BC.1
8830	12 T 706A/2	BC.1		12 T 707A	BC.1
				12 T 708A	BC.1

PAGE BC.4

Ref. No.	Part No.	Plate No.	Ref. No.	Part No.	Plate No.
	12-2TP 41A/ND	BC.1	8188	12-2TR 81A	BF.1
	12 T 501	BC.1	9351	12-2TR 337A	BF.1
	12 T 502	BC.1	6638	12-2TP 1A	BG.1
26FC/3199	J.00896	BC.1	222	12 T 69	BC.1
26FC/7392	J.00355A	BC.1	223	12 T 71	BC.1
26FC/3178	J.00894	BC.1	1181	12 T 223	BC.1
26FC/2442	J.00453	BC.1		12 T 561A/ND	BC.1

## HAND INK ALTERATIONS

Insert in the "Plate No." Column the following plate numbers against the undermentioned Part Numbers :-

## PAGE BD.1

Ref. No.	Part No.	Plate No.	Ref. No.	Part No.	Plate No.
9349	12-4 TE 1A/1	BC.1 & BD.1		J.001645	BD.1
7688	12 TE 781A	BC.1 & BD.1		12 TE 395	BD.1
	12 TE 195A	BD.2	1315	12 TE 439	BD.2
	12 TE 375A	BD.2	1286	12 TE 179	BD.2
	12 TE 289A	BD.1	26FC/3161	J.00793	BD.1
4644	12-20 TE 313A	BD.1		12-20 TE 181	BD.2
			8155	12 TE 823A	BD.1

## PAGE BD.2

Ref. No.	Part No.	Plate No.	Ref. No.	Part No.	Plate No.
26FC/3162	J.00783	BD.1	5117	12 TE 120A/1	BD.2
5114	12 TE 133	BD.2	3842	12 TE 123	BD.2
7809	12 TE 413A	BD.2	1950	12 TE 503	BD.2
1283	12 TE 415	BD.2	5110	12 TE 149	BD.2
26FC/2440	J.00171A	BD.2		12 TE 683	BD.2
26BY/5803	J.98484	BD.2	6407	12 TE 679A	BD.2
3825	12 TE 97A	BD.1	6408	12 TE 681A	BD.2
3824	12 TE 101A	BD.1	1286	12 TE 179	BD.2
5116	12 TE 119A/1	BD.2	3840	12 TE 291	BD.2
			3827	12 TE 299	BD.2

## PAGE BD.3

Ref. No.	Part No.	Plate No.	Ref. No.	Part No.	Plate No.
	12 TE 381A	BD.1		12 TE 441A	BD.2
26FC/2440	J.00171A	BE.2		12 TE 555A	BD.2
5110	12 TE 149	BD.2		12-20TE 335	BD.1
	12 TE 553	BD.1		12-20TE 323A	BD.1
26FC/3160	J.00916A	BD.1	3839	12 TE 201A	BD.2
3843	12 TE 115	BD.2	9225	12 TE 277	BD.1
26FC/3168	J.00744A	BD.1	3833	12 TE 301	BD.2
1284	12 TE 409A	BD.1	882	J.777	BD.1
3971	12 TE 113	BD.1		12 TE 669A	BD.3
	12 TE 193	BD.3	26FC/2404	J.00302	BD.1

## PAGE BD.4

Ref. No.	Part No.	Plate No.	Ref. No.	Part No.	Plate No.
10458	12 TE 773A	BD.2	1294	12 TE 53A/1	BD.1
	12-20 TE 163	BD.2	26FC/4171	J.001807ND	BD.1
	12-20 TE 171	BD.2	26FC/4347	J.001829	BD.1
	12-20TE 229	BD.2		J.00451	BD.1
	12-20TE 185A/1	BD.2		12 TE 233ND	BD.1
	12 TE 777	BD.2	26FC/6433	J.001492A	BD.1
	12-20TE 165	BD.2	4834	12 TE 145	BD.1
	12 TE 769	BD.2	1530	12 TE 57A/1	BD.2
	12-20TE 159	BD.2	1528	12 WA 717	BD.2
	12-20TE 481	BD.2	9526	12 TE 279A	BD.2
	12-20TE 483	BD.2		12 TE 313	BD.2
3828	12 TE 183	BD.2		12 TE 315	BD.2
			1503	12 TE 453	BD.2

## PAGE BD.5

Ref. No.	Part No.	Plate No.	Ref. No.	Part No.	Plate No.
	J.00901	BD.1		12 TE 565A/2	BD.5
3970	12 TE 401A	BD.1	2561	12-20TE 247	BD.1
			2562	12-20TE 249	BD.1

RESTRICTED

Issued with AL/2

PART 1

Venom FB Mk. 4

HAND INK ALTERATIONS

Insert in the "Plate No." Column the following plate numbers against the undermentioned Part Numbers :-

PAGE BE.1

Ref. No.	Part No.	Plate No.	Ref. No.	Part No.	Plate No.
8829	12 T 705A/2	BE.1	26FC/3239	K.00364	BE.1
8830	12 T 706A/2	BE.1		K.00355A	BE.1
	12 TB 59	BE.1	26FC/3238	K.00352	BE.1
	12 TB 231A	BE.1	26FC/3264	K.00471A	BE.1
	12 TB 232A	BE.1	26FC/3951	K.00455	BE.1
26FC/3238	K.00352	BE.1	26FC/3263	K.00470A	BE.1
26FC/3263	K.00470A	BE.1		12 TB 21	BE.1

PAGE BE.2

Ref. No.	Part No.	Plate No.	Ref. No.	Part No.	Plate No.
	12 TF 99A	BE.1		12 TF 100A	BE.1
8023	12-2TF 101A	BE.1	8845	12 TF 162A/ND	BE.1
	12-2TF 289A	BE.1	26FC/2478	J.00484A	BE.1
	12-2TF 281A	BE.1	26FC/2476	J.0064	BE.1
			26FC/2475	J.0063	BE.1

PAGE BE.3

Ref. No.	Part No.	Plate No.	Ref. No.	Part No.	Plate No.
26FC/2447	J.0065	BE.1	26FC/2493	J.00133	BE.1
26FC/2479	J.00618ND	BE.1	26FC/3950	J.00786	BE.1

PAGE BF.1

Ref. No.	Part No.	Plate No.	Ref. No.	Part No.	Plate No.
8188	12-2TR 81A	BF.1	26FC/4699	J.001795	BF.1
9351	12-2TR 337A	BF.1	9370	12 TR 17	BF.1
	12-2TR 109ND	BF.1		12-2TR 391A/ND	BF.1
	J.001043A	BF.1		12-2TR 387A/ND	BF.1
26FC/3357	J.00755	BF.1		12-2TR 389A/ND	BF.1
26FC/3358	J.00756A	BF.1		12-2TR 83A	BF.1
	J.001043A	BF.1		12-2TR 231A	BF.1
	12-2TR 233	BF.1	5096	12-2TR 229	BF.1
			5093	12-2TR 217A	BF.1

PAGE BG.1

Ref. No.	Part No.	Plate No.	Ref. No.	Part No.	Plate No.
6638	12-2TP 1A	BG.1		J.00872	BG.1
26FC/2525	J.00197	BG.1	27S/137	I.132630	BG.1
26FC/3181	J.00588	BG.1		J.00526A	BG.1
26FC/3180	J.00196A	BG.1	26FC/3060	G.00656A	BC.1
225	12 TP 21	BG.1		J.00367	BG.1
226	12 TP 23	BG.1		J.00525	BG.1
	12 TP 105A	BG.1	26BY/244	D.98435	BG.1
26FC/3360	J.00873	BG.1	26FC/2514	J.00359	BC.1
26FC/2524	J.00893	BG.1	26FC/3187	J.001015A	BG.1
			26FC/2519	J.00263	BG.1

PAGE BG.2

Ref. No.	Part No.	Plate No.	Ref. No.	Part No.	Plate No.
26FC/2520	J.00264	BG.1	26FC/3179	J.00874	BG.1
1092	12 TP 83A	BG.1	26FC/8651	J.00261	BG.1

This file was downloaded  
from the RTFM Library.  
Link: [www.scottbouch.com/rtfm](http://www.scottbouch.com/rtfm)

Please see site for usage terms,  
and more aircraft documents.

