

ENGINE AND TRIM CONTROLS IN FUSELAGE

Ref. No.	Part No.	Nomenclature						No Off	M.R.	Cl. of St.	Plate No.
		1	2	3	4	5	6				
	—	ENGINE AND TRIM CONTROLS IN FUSELAGE (12 CE 337)						1	—		E.1
	B.13374	ADAPTOR , 2 BA, L.H. thread, Teleflex						2	—		E.1
	B.13373	ADAPTOR , 2 BA, R.H. thread, Teleflex						2	—		E.1
27K/518	A.13376	END , screwed, for L.H. thread						1	—	C.	
27K/519	A.13375	END , screwed, for R.H. thread						1	—	C.	
27K/502	DS.94/2	NUT , lock						1	—	C.	
27K/503	A.10704	PLUG , end						1	—	C.	
27K/504	DS.47/2	SPRING , lock						1	—	C.	
27K/505	B.10140	WASHER , tab						1	—	C.	
26FC/2081	28/92B	BARREL , adjuster, elevator trim indicator control, at engine control box, Bowden						2	—	C.	
26BY/10509	L.983508	BARREL , adjuster, on throttle and fuel cock control conduits between bulkheads No. 2 and 3						2	—	C.	E.1
26FC/2087	L.00611A	BLOCK , clamp, for Teleflex conduits in cockpit ...						1	—	C.	
		Attaching parts for L.00611A, Block :—									
28D/12566	A25/6C	Bolt, 2 BA						2	—	C.	
28W/12252	SP.13/C	Washer						2	—	C.	
28L/11069	AGS.2035/C	Washer						2	—	C.	
794	12 CE 189	BLOCK , clamp, half, lower for Teleflex conduits at bulkhead No. 3						1	MR	C.	E.1
		Attaching parts for 12 CE 189, Blocks :—									
28D/12540	A25/18C	Bolt, 2 BA						2	MR	C.	E.1
793	12 CE 187	BLOCK , clamp, half, upper, for Teleflex conduits at bulkhead No. 3						1	MR	C.	E.1
		Attaching parts for 12 CE 187, Block :—									
28D/12515	A25/10C	Bolt, 2 BA						4	MR	C.	
28M/10288	AGS.2001/C/1	Nut, 2 BA						4	MR	C.	
26FC/3636	L.00562	BLOCK , mounting, conduit pressure seals on bulkhead No. 2						1	—	C.	E.1
	12 CE 339A/1	BOX , control (See Separate Unit) (Mod. Ven. 560) ...						1	—		E.1
		Attaching parts for 12 CE 339A/1, Box :—									
28D/12708	AS.1246/9C	Bolt, 2 BA						5	—	C.	
27K/191	DS.23/1	CABLE , Teleflex No. 1						QR	—	C.	
27K/192	DS.23/2	CABLE , Teleflex No. 2						QR	—	C.	
26BY/753	K.98244	CLAMP , conduit, aft of bulkhead No. 3						4	—	C.	E.1
		Attaching parts for K.98244, Clamp :—									
28M/10288	AGS.2001/C/1	Nut, 2 BA						4	—	C.	
28W/12252	SP.13/C	Washer						4	—	C.	
29H/4088	T.2AH-BOWDEN	CONDUIT , elevator trim indicator control						QR	—	C.	
27K/196	DS.56/2	CONDUIT , Teleflex No. 2						QR	—	C.	
27K/568	B.29140	CONNECTOR , conduit, at bulkheads No. 2 and 3, Teleflex						3	—	C.	
26FC/2933	K.00410	CONNECTOR , elevator trim cables, at indicator ...						1	—	C.	E.1
		Attaching parts for K.00410, Connector :—									
26FC/2934	K.00415	Bolt						1	—	C.	E.1

CONTROLS

ENGINE AND TRIM CONTROLS IN FUSELAGE

Ref. No.	Part No.	Nomenclature						No. Off	M.R.	Cl. of Sc.	Plate No.
		1	2	3	4	5	6				
26FC/2073	PN.974/A	FERRULE , elevator trim indicator control, at engine control box, Bowden						4	—	C.	
27K/735	A.14056	FOIL , lead, at clamp block, bulkhead No. 3 ...						QR	MR	C.	E.1
27K/717	B.10898	GREASER , cable lubricating, at bulkhead No. 3, Teleflex						2	—	C.	E.1
26FC/4701	L.002703	GREASER , cable lubricating, forward of bulkhead No. 2, Teleflex						5	—	C.	E.1
	12-4 CE 1	GUARD , cable, between bulkheads No. 2 and 3 ... (Pre Mod. Ven. 886)						1	—	C.	E.1
		GUARD , cable, between bulkheads No. 2 and 3 (Make from 26FC/4701 Mod. Ven. 886)						1	—		E.1
26FC/4328	K.00414A/1	INDICATOR , elevator trim (Pre Mod. Ven. 751) ...						1	—	C.	E.1
26FC/2930	K.00544	ARM , pointer ...						1	—	C.	E.1
	K.00409	PIN , pulley mounting (Make from A.M. Ref. No. 28P/873)						1	—		
28FC/4326	L.003215	POINTER , position ...						1	—	C.	E.1
26FC/2931	K.00411	PLUNGER ...						1	—	C.	E.1
26FC/2932	K.00408	PULLEY , trim cable ...						1	—	C.	E.1
26FC/2079	L.00636	SCREW , grub ...						1	—	C.	E.1
28D/12629	A25/8C	Attaching parts for K.00414A/1, Indicator :—									
28M/10288	AGS.2001/C/1	Bolt, 2 BA ...						2	—	C.	
		Nut, 2 BA ...						2	—	C.	
	12 FC 165A	INDICATOR , elevator trim (Mod. Ven. 751) ...						1	—		
	12 FC 169A/ND	BODY AND PULLEY, ASSEMBLY , comprising :						1	—		
26FC/2930	K.00544	ARM , pointer ...						1	—	C.	
	12 FC 163	BODY ...						1	—		
	K.00409	PIN , pulley, mounting (Make from Ref. No. 28P/873, Part No. SP4Y/D.15)						1	—		
26FC/2931	K.00411	PLUNGER ...						1	—	C.	
26FC/2932	K.00408	PULLEY , trim cable ...						1	—	C.	
26FC/2079	L.00636	SCREW , grub ...						1	—	C.	
28L/11066	AGS.2035/A	LOCKWASHER ...						1	—	C.	
26FC/4326	L.003215	POINTER , position ...						1	—	C.	
	L.003227ND	SCREW (Make from 28S/2857-A32/B12) ...						1	—		
	L.003229ND	WASHER (Make from AS.470/B-28W/8515) ...						1	—		
		Attaching parts for 12 FC 165A, Indicator :—									
28D/12629	A25/8C	Bolt, 2 BA ...						2	—	C.	
28M/10288	AGS.2001/C/1	Nut, 2 BA ...						2	—	C.	
26FC/2080	PN.8	LOCKNUT , elevator, trim indicator control, at engine control box, Bowden						4	—	C.	
27K/571	A.821	NIPPLE , connecting conduits to engine control box, Teleflex						8	—	C.	
	L.00435A	PLATE , bolt, for conduit clamps aft of bulkhead No. 3						4	—		E.1
	12 CE 219	PLATE , clamp, for upper conduit clamps aft of bulkhead No. 3, 30 SWG, S.84 (Make from Ref. No. 30A/2159)						2	—		E.1
		Attaching parts for 12 CE 219, Plate :—									
28M/10286	AGS.2001/A/1	Nut, 6 BA ...						2	—	C.	
28S/6472	A33/A6	Screw, 6 BA ...						2	—	C.	
28W/12332	SP.13/A	Washer ...						2	—	C.	
26FC/5947	15 CE 605	PLUG , seal retaining bulkhead No. 2 control cable conduit						1	—	C.	E.1
		Attaching parts for 15 CE 605, Plug :—									
26FC/2085	HO.25	Seal, Angus ...						1	—	C.	E.1
26FC/2082	L.00323A	ROD , connecting, from control box to selector valve, for flaps, undercarriage and dive brakes						3	—	C.	E.1
26FC/2083	L.00324	EYE-END ...						1	—	C.	E.1
26FC/2084	L.00326	LOCKNUT , for eye-end ...						1	—	C.	E.1
		Attaching parts for L.00323A, Rod :—									
28P/829	SP4Y/B3	Pin, shackle ...						2	—	C.	
28P/12587	SP.9/C4	Pin, split ...						2	—	C.	
26FC/2085	HO.25	SEAL , at bulkhead No. 2, for control cable conduits, Angus						7	—	C.	
		Attaching parts for HO.25, Seal :—									
26FC/2086	L.00563	Nut, seal retaining ...						1	—	C.	E.1

CONTROLS
CONTROL BOX

Ref. No.	Part No.	Nomenclature						No. Off	M.R.	Cl. of St.	Plate No.
		1	2	3	4	5	6				
	12 CE 339A/1	BOX, CONTROL (Mod. Ven. 560)						1	—		
27S/165	I.132405	BEARING , ball-race, for trim wheel, Skefko... ..						1	—	B.	
26FC/2112	L.00714A	BELLCRANK , dive brake lever control rod... ..						1	—	C.	EA.1
		Attaching parts for L.00714A, Bell-crank :—									
28N/13091	AGS.2031/6	Circlip, external, for $\frac{3}{8}$ " dia. spindle, Seeger						1	—	C.	
28M/10331	AGS.2002/G/1	Nut, $\frac{1}{16}$ " BSF						1	—	C.	
26FC/2094	L.00732	Spindle						1	—	C.	EA.1
28W/12324	SP.15/G	Washer						1	—	C.	
26FC/3961	L.001366	BOLT , stop, for control levers						6	—	C.	EA.1
		Attaching parts for L.001366, Bolt :—									
28L/5234	A14/CB	Nut, 2 BA						1	—	C.	
26K/750	B.16658	BOX , control, canopy sealing, Teleflex						1	—	B.	
27K/751	B.16660	BOX , control, elevator trim, Teleflex						1	—	B.	
		Attaching parts for B.16658 and B.16660, Boxes (per pair) :—									
28D/11978	AS.1246/15C	Bolt, 2 BA						2	—	C.	
26FC/3960	L.001381	Bolt, 2 BA, through boxes and gear						1	—	C.	
28M/10328	AGS.2002/C/1	Nut, 2 BA						3	—	C.	
26FC/2036	DHS.69/CC	Shim, 2 BA between boxes						4	—	C.	
	L.001379ND	Washer, between box and pinion, 0.8" o/d x $\frac{17}{32}$ " i/d x 0.1" thick, L.72						1	—	C.	
28W/12296	SP.15/C	Washer, under gear nut						1	—	C.	
27K/1346	C.40961	BOX , control, wrapped unit for throttle and H.P. cock, complete with lever, Teleflex						1	—	B.	
		Attaching parts for C.40961, Box, Control :—									
28D/12120	AS.1242/16C	Bolt, 2 BA						1	—	C.	
28D/11947	AS.1246/16C	Bolt, 2 BA						2	—	C.	
28M/10328	AGS.2002/C/1	Nut, 2 BA						3	—	C.	
26FC/2124	L.00335	BRACKET , mounting, micro switch at undercarriage selector lever						1	—	C.	EA.1
		Attaching parts for L.00335, Bracket :—									
28D/11564	AS.1246/1C	Bolt, 2 BA						2	—	C.	
28M/10288	AGS.2001/C/1	Nut, 2 BA						2	—	C.	
28W/12245	SP.10/C	Washer						2	—	C.	
	12 F 1927	BRACKET , mounting switch on dive brake lever						1	—		EA.1
		Attaching parts for 12 F 1927, Bracket :—									
28D/12137	AS.1246/4B	Bolt, 4 BA						2	—	C.	
28L/11067	AGS.2035/B	Lockwasher						2	—	C.	
11437	12 CE 257	BUTTON , stop, dive brake control lever						2	—	C.	EA.1
26FC/3332	B.001025A	CABLE , control, gyro gunsight						2	—	C.	
29H/1903	BOWDEN PN.484	ADJUSTER						1	—	C.	
29H/1902	BOWDEN PN.999	BARREL						1	—	C.	
29H/4110	BOWDEN PN.23	LOCKNUT						1	—	C.	
26FC/4877	B.00329	NIPPLE						2	—	C.	

CONTROLS

CONTROL BOX

Ref. No.	Part No.	Nomenclature						No. Off	M.R.	Cl. of St.	Plate No.
		1	2	3	4	5	6				
26FC/6416	L.00635ND	CABLE , flexible, for trim indicator, 5 cwt., 8'-0" long, W.9						1	—	C.	
	12 CE 243	CLAMP , cable						1	—		EA.1
		Attaching parts for 12 CE 243, Clamp :—									
28D/12512	A25/1C	Bolt, 2 BA						1	—	C.	
28M/12929	A27/CP	Nut, 2 BA						1	—	C.	
28W/12245	SP.10/C	Washer						1	—	C.	
27K/196	DS.56/2	CONDUIT , teleflex No. 2						QR	—	C.	
	12 CE 329A/ND	CONDUIT , H.P. front, fuel cock control						3	—		
	12 CE 331A/ND	CONDUIT , front, throttle control						3	—		
	12 CE 333A/ND	CONDUIT , front throttle control						3	—		
	12 CE 301A/ND	CONDUIT , front, fuel cock control						3	—		
	L.003185A/ND	CONDUIT , front fuel cock control						3	—		
	12 CE 235A	DAMPER , friction, front, for throttle control lever						1	—		EA.1
	12 CE 237A	DAMPER , friction, rear, for throttle control lever						1	—		EA.1
26FC/2100	L.00727	WASHER , friction						1	—	C.	EA.1
	12 CE 291A	GATE , flap and undercarriage levers						1	—		EA.1
		Attaching parts for 12 CE 291A, Gate :—									
28D/11937	AS.1246/1B	Bolt, 4 BA						8	—	C.	
28M/10327	AGS.2002/B/1	Nut, 4 BA						2	—	C.	
28M/10287	AGS.2001/B/1	Nut, 4 BA						6	—	C.	
	12 F 1925	GUARD AND LABEL , "Aileron trim P and S"						1	—		EA.1
		Attaching parts for 12 F 1925, Guard and Label :—									
28D/12528	A25/1B	Bolt, 4 BA						2	—	C.	
28W/12305	SP.13/B	Washer						2	—	C.	
26FC/2727	L.001351A	HUB , for fuel cock control lever						1	—	C.	EA.1
		Attaching parts for L.001351A, Hub :—									
28N/13018	AGS.2031/2	Circlip, external for 1/2" dia. spindle, Seeger						1	—	C.	
26FC/2115	L.00738A	HUB , for throttle and gyro gunsight control lever						1	—	C.	
26FC/2107	L.00847A	KNOB , dive brake lever						1	—	C.	EA.1
		Attaching parts for L.00847A, Knob :—									
28L/13326	A.27/GT	Locknut, 5/16" BSF						1	—	C.	
26FC/2108	L.00848A	KNOB , flap selector lever						1	—	C.	EA.1
		Attaching parts for L.00848A, Knob :—									
28L/13326	A.27/GT	Locknut, 5/16" BSF						1	—	C.	
	12 F 1311	LABEL , "dive brakes-IN-OUT"						1	—		EA.1
		Attaching parts for 12 F 1311, Label :—									
28D/12137	AS.1246/4B	Bolt, 4 BA						3	—	C.	
28L/11067	AGS.2035/B	Lockwasher						3	—	C.	
	L.00851	LABEL , "Fuel-off"						1	—		EA.1
	L.00852	LABEL , "Fuel-on"						1	—		EA.1
	12 CE 313	LABEL , "Shut-Cock Control-Open"						1	—		EA.1
	12 CE 311	LABEL , "Shut throttle open"						1	—		EA.1
	L.00579	LABEL , "undercarriage flaps"						1	—		EA.1
26FC/2111	L.00711A	LEVER , dive brake control						1	—	C.	EA.1
		Attaching parts for L.00711A, Lever :—									
28N/12729	AGS.2031/9	Circlip... ..						1	—	C.	

CONTROLS
CONTROL BOX

Ref. No.	Part No.	Nomenclature						No Off	M.R.	Cl. of St.	Plate No.
		1	2	3	4	5	6				
26FC/2102	L.00812A	LEVER , flap selector						1	—	C.	EA.1
	L.002709A	LEVER , undercarriage selector, complete						1	—	C.	EA.1
26FC/3759	L.002344	KNOB , half						1	—	C.	EA.1
26FC/3760	L.002345	KNOB , half						1	—	C.	EA.1
		Attaching parts for L.002344 and L.002345, Knobs (per pair) :—									
28D/8307	AS.1242/2C	Bolt, 2 BA						1	—	C.	
28L/13124	A.27/CT	Locknut, 2 BA						1	—	C.	
		LEVER						1	—		EA.1
		KNOB						2	—		EA.1
		Attaching parts for L.002713, Knob :—									
		Bolt, special						1	—		EA.1
28M/10287	AGS.2001/B/1	Nut, 4 BA						1	—	C.	
28W/12305	SP.13/B	Washer						1	—	C.	
		SPRING						1	—		EA.1
		STUD , contact						1	—		EA.1
26FC/2103	L.00806	SPRING , leaf						1	—	C.	EA.1
		Attaching parts for L.00812A and L.002709A, Levers (per pair) :—									
		Collar, $\frac{7}{8}$ " o/d x 17 SWG x 0.32" long, T.45						1	—		
		(Make from 30A/1771)									
26FC/2096	L.00341	Spindle						1	—	C.	EA.1
28W/12296	SP.15/C	Washer						3	—	C.	
26FC/2104	L.00849A	LEVER , fuel cock control						1	—	C.	EA.1
		Attaching parts for L.00849A, Lever :—									
		Pin, $\frac{1}{8}$ " dia. x 0.95", S.1 (Make from 30A/395)						2	—		
		LEVER , throttle and gyro gunsight control						1	—		EA.1
26FC/2119	L.00825	NUT , for handgrip						1	—	C.	EA.1
26FC/2120	L.00969	PULLEY , cable operating						1	—	C.	EA.1
		SHIM , under pulley						1	—		EA.1
		SPINDLE , for handgrip						1	—		EA.1
		Attaching parts for 12 CE 245A, Lever :—									
28D/12515	A25/10C	Bolt, 2 BA						1	—	C.	
28M/10328	AGS.2002/C/1	Nut, 2 BA						1	—	C.	
		PLATE , cover, under dive brake label, for dive brake control lever stop button, 14 SWG, L.72 (30B/1726)						1	—		EA.1
		Attaching parts for L.00733, Plate :—									
28D/11937	AS.1246/1B	Bolt, 4 BA						1	—	C.	
28L/11067	AGS.2035/B	Lockwasher						1	—	C.	
		ROD , connecting, dive brake control lever to bell crank						1	—		EA.1
		BALL-JOINT (Make from 28N/544)						1	—		EA.1
		BALL-JOINT , complete						1	—	C.	
28N/544	AGS.385	BALL-BOLT						1	—	C.	
28N/10619	AGS.285/B	PLUG						1	—	C.	
28N/10378	AGS.385/C	SOCKET						1	—	C.	
28N/10377	AGS.385/A	LOCKNUT , $\frac{1}{4}$ " BSF						2	—	C.	
28L/12931	A.27/ET	ROD , connecting						1	—		EA.1
		Attaching parts for L.00713A, Rod :—									
28L/12931	A.27/ET	Nut, $\frac{1}{4}$ " BSF						2	—	C.	

CONTROLS

CONTROL BOX

Ref. No.	Part No.	Nomenclature						No. Off	M.R.	Cl. of Sc.	Plate No.
		1	2	3	4	5	6				
	12 CE 227	SHAFT , throttle lever damper						1	—		EA.1
		Attaching parts for 12 CE 227, Shaft :—									
28M/13121	A27/CS	Nut, 2 BA						1	—	C.	
28M/15254	A27/EPL	Nut, 1/4" BSF						1	—	C.	
28W/12252	SP.13/C	Washer						1	—	C.	
	12 CE 229	SPINDLE , for damper screw guide						1	—		EA.1
		Attaching parts for 12 CE 229, Spindle :—									
28N/12729	AGS.2031/9	Circlip... ..						1	—	C.	
26FC/2095	L.00737	SPRING , compression, for dive brake control lever stop button						2	—	C.	EA.1
26FC/2097	L.00336	SPRING , contact, undercarriage selector lever and micro switch						1	—	C.	EA.1
	12 CE 279	STOP , safety, H.P. cock lever						1	—		EA.1
		Attaching parts for 12 CE 279, Stop :—									
28D/8308	AS.1242/3C	Bolt, 2 BA						2	—	C.	
28M/10288	AGS.2001/C/1	Nut, 2 BA						2	—	C.	
	12 CE 281	Packing, piece						1	—		EA.1
28W/12296	SP.15/C	Washer						2	—	C.	
	N.00267A	SWITCH , micro, complete with cable, at undercarriage selector valve						1	—		EA.1
5E/1362		CABLE , Duclal 4 amp						QR	—	C.	
5K/2576	No. 1	SLEEVE , binding						2	—	C.	
5K/2577	No. 2	SLEEVE , binding						2	—	C.	
5CW/1789	†	SWITCH , micro						1	—	B.	
		Attaching parts for L.00336, spring and N.00267A, Switch (per pair) :—									
28D/12565	A25/BB	Bolt, 4 BA						2	—	C.	
28M/13086	A27/BP	Nut, 4 BA						2	—	C.	
28W/12305	SP.13/B	Washer						2	—	C.	
5CW/4168	MS.7609/FAM.3	SWITCH , undercarriage lock, magnetic plunger, Franco British						1	—	A.	
		Attaching parts for MS.7609/FAM3, Switch :—									
28D/11210	AS.1246/3C	Bolt, 2 BA						3	—	C.	
5CW/4178	D.5403	SWITCH , Rotax, on dive brake lever... ..						1	—	B.	
26FC/2090	L.00707	WHEEL , hand, elevator trim control						1	—	C.	EA.1
		Attaching parts for L.00707, Wheel :—									
28N/13018	AGS.2031/2	Circlip, external, for 1/2" dia., spindle						1	—	C.	
	L.001397ND	Shim, 3/4" o/d. x 1/2" i/d. x 12 SWG, L.72						1	—		EA.1

ENGINE CONTROLS ON FIREPROOF BULKHEAD

Ref. No.	Part No.	Nomenclature						No. Off	M.R.	Cl. of St.	Plate No.
		1	2	3	4	5	6				
	—	ENGINE CONTROLS ON FIREPROOF BULK-HEAD (12 E 9A)						1	—		
27K/750	B.16658	BOC , control, at upper layshafts, Teleflex						3	—	C.	EB.1
		Attaching parts for B.16658, Box :—									
28D/12514	A25/7C	Bolt, 2 BA						3	—	C.	
579	12 CE 27A	BRACKET , bearing for centre and bottom upper layshafts						1	MR	C.	EB.1
		Attaching parts for 12 CE 27A Bracket :—									
28D/12512	A25/1C	Bolt 2 BA						5	MR	C.	
2176	12 CE 75A	BRACKET , bearing, for lower layshaft, inner ...						1	MR	C.	EB.1
		Attaching parts for 12 CE 75A, Bracket :—									
28D/12512	A25/1C	Bolt, 2 BA						3	MR	C.	
587	12 CE 171A	BRACKET , bearing, for lower layshaft, outer ...						1	MR	C.	EB.1
		Attaching parts for 12 CE 171A, Bracket :—									
28D/12512	A25/1C	Bolt, 2 BA						4	MR	C.	
584	12 CE 115A	BRACKET , bearing, for top layshaft						1	MR	C.	EB.1
		Attaching parts for 12 CE 115A, Bracket :—									
28D/12512	A25/1C	Bolt, 2 BA						3	MR	C.	
7103	12 CE 73	BRACKET , mounting, for Teleflex control box at bottom upper layshaft						1	MR	C.	EB.1
7102	12 CE 71	BRACKET , mounting, for Teleflex control box at centre upper layshaft						1	MR	C.	EB.1
7101	12 CE 69	BRACKET , mounting, for Teleflex control box at top upper layshaft						1	MR	C.	EB.1
		Attaching parts for 12 CE 73, 12 CE 71 and 12 CE 69, Brackets :—									
28D/12512	A25/1C	Bolt, 2 BA						6	MR	C.	
5250	12 CE 29A	CAM , on top layshaft, inner						1	MR	C.	EB.1
	L.001360A	BOLT						1	MR	C.	EB.1
28M/10288	AGS.2001/C/1	NUT , 2 BA						1	MR	C.	
28W/12252	SP.13/C	WASHER						1	MR	C.	
27KB/16	AS.201/27P	CHAIN , for throttle, H.P. fuel cock cut-off, and L.P. fuel cock						6	—	B.	EB.1
	12 CE 119	CLAMP , end, for tie-rod fairleads L.H., 12 SWG, L.72...						2	—		EB.1
		Attaching parts for 12 CE 119, Clamp :—									
28D/12631	A25/23C	Bolt, 2 BA						3	—	C.	
	12 CE 121	CLAMP , end, for tie-rod fairleads, R.H., 20 SWG, L.72						2	—		EB.1
		Attaching parts for 12 CE 121, Clamp :—									
28D/12631	A25/23C	Bolt, 2 BA						2	—	C.	
	12 CE 105	FAIRLEAD , centre, for tie rods on L.H. side of fire-proof bulkheads						2	MR		EB.1
	12 CE 107	FAIRLEAD , outer, for tie rods						8	MR		EB.1

ENGINE CONTROLS OF FIREPROOF BULKHEAD

Ref. No.	Part No.	Nomenclature						No. Off	M.R.	Cl. of St.	Place No.
		1	2	3	4	5	6				
581	12 CE 63A	LAYSHAFT , control, bottom upper						1	MR	C.	EB.1
582	12 CE 65A	LAYSHAFT , control, centre upper						1	MR	C.	EB.1
583	12 CE 67A	LAYSHAFT , control, top upper						1	MR	C.	EB.1
28D/12088	AS.1246/7C	BOLT , 2 BA						2	MR	C.	
28M/10288	AGS.2001/C/1	NUT , 2 BA						2	MR	C.	
28P/1284	AGS.167/22	PIN , taper, solid, for chain sprocket wheel ...						2	MR	C.	
26FC/2150	L.001216	SOCKET , end, serrated						1	MR	C.	EB.1
2953	12 CE 61	WHEEL , chain sprocket						1	MR		EB.1
Attaching parts for 12 CE 63A, 12 CE 65A and 12 CE 67A, Layshafts :—											
28D/12515	A25/10C	Bolt, 2 BA						1	MR	C.	
28M/10288	AGS.2001/C/1	Nut, 2 BA						1	MR	C.	
28M/12930	A27/ES	Nut, 1/4" BSF						1	MR	C.	
28P/12462	SP.9/C8	Pin, split						1	MR	C.	
28W/12252	SP.13/C	Washer						1	MR	C.	
8101	12 CE 351	LAYSHAFT , lower (Mod. Ven. 579)						1	MR	C.	
Attaching parts for 12 CE 351, Layshaft :—											
28D/12512	A25/1C	Bolt, 2 BA, at chain guard						1	MR	C.	
28M/12930	A27/ES	Nut, 1/4" BSF						1	MR	C.	
28P/12462	SP.9/C8	Pin, split						1	MR	C.	
28L/5233	A14/BB	LOCKNUT , 4 BA, for tie-rods... ..						6	—	C.	
28L/5220	A14/BBL	LOCKNUT , 4 BA, L.H., thread for tie-rods ...						6	—	C.	
8100	12 CE 357A	ROD , connecting, H.P. fuel cock cut-off control (Mod. Ven. 579)						1	—	C.	EB.1
8099	12 CE 355A	ROD , connecting, throttle control (Mod. Ven. 579)						1	—	C.	EB.1
8098	12 CE 353	FORK-END , (Mod. Ven. 579)						1	—	C.	
28L/13454	A.27/ETL	LOCKNUT , 1/4" BSF, thin, L.H. thread						1	—	C.	
28L/13326	A.27/GT	LOCKNUT , 5/16" BSF, thin						1	—	C.	
Attaching parts for 12 CE 357A and 12 CE 355A, Rods:—											
26BY/1931	L.98177	Pin, shackle						1	—	C.	EB.1
28P/12431	SP.9/C3	Pin, split						1	—	C.	
26BY/1920	L.98178	Shim						1	—	C.	EB.1
580	12 CE 53A	SHAFT , drive, fuel cock						1	MR	C.	EB.1
Attaching parts for 12 CE 53A, Shaft :—											
28D/12515	A25/10C	Bolt, 2 BA						1	MR	C.	
28M/10288	AGS.2001/C/1	Nut, 2 BA						1	MR	C.	
28A/1345	B.255	TIE-ROD , 4 BA, for H.P. fuel cock cut-off, 24-0" long						2	—	C.	EB.1
28A/1346	B.295	TIE-ROD , 4 BA, for L.P. fuel cock, 26-0" long ...						2	—	C.	EB.1
28A/1346	B.295	TIE-ROD , 4 BA, for throttle control, 28-5" long ...						2	—	C.	EB.1

FLYING CONTROLS IN BOOMS

Ref. No.	Part No.	Nomenclature						No. Off	M.R.	Cl. of St.	Plate No.
		1	2	3	4	5	6				
	—	FLYING CONTROLS IN PORT AND STARBOARD BOOMS (12 CF 1037)						1	—		
28D/13262	A20/6E	BOLT , 1/4" BSF, attaching rudder balance lever link plates to operating lever						1	—	C.	
28D/11738	AS.2504/7G	BOLT , 1/8" BSF attaching, connecting rod to rudder operating lever						1	—	C.	
26FC/2613	J.00268	BRACKET , angle, for control levers bracket attachment						6	—	C.	EC.1
	12 CF 1031A/1	BRACKET , complete with control levers, rear boom, Port						1	—		EC.1
	12 CF 1033A/1	BRACKET , complete with control levers, rear boom, Starboard						1	—		EC.1
26FC/4625	J.001899	BOLT , stop control lever buffer						1	—	C.	EC.1
26FC/6694	12 CF 701	BOLT , stop control lever buffer, port (1) Starboard (3)						4	—	C.	EC.1
		Attaching parts for J.001899 and 12 CF 701, Bolts :—									
28M/13375	A27/GP	Nut, 1/8" BSF						1	—	C.	
26FC/3236	J.00602A	BRACKET , hinge, bottom of rudder torque tube						1	—	B.	EC.1
27S/142	SKEFKO. I.132498	BEARING , ball-race						1	—	B.	
		Attaching parts for J.00602A, Bracket :—									
28D/12543	A25/6E	Bolt, 1/4" BSF, bottom						2	—	C.	
28D/12674	A25/9E	Bolt, 1/4" BSF, top						2	—	C.	
28M/12928	A27/EP	Nut, 1/4" BSF						4	—	C.	
28W/12253	SP.13/E	Washer						8	—	C.	
26FC/3235	J.00563	BRACKET , mounting						1	—	C.	EC.1
26FC/3237	J.00604	BRACKET , support, for control levers						2	—	C.	EC.1
		Attaching parts for J.00604, Bracket :—									
28D/12543	A25/6E	Bolt, 1/4" BSF, bottom						1	—	C.	
28D/12674	A25/9E	Bolt, 1/4" BSF, top						1	—	C.	
28M/12928	A27/EP	Nut, 1/4" BSF						2	—	C.	
28W/12253	SP.13/E	Washer						4	—	C.	
26FC/2607	J.00255	BUSH , threaded for stop bolts						6	—	C.	EC.1
4845	12 CF 373A	LEVER , elevator control, Starboard						1	—	B.	EC.1
27S/137	SKEFKO I.132630	BEARING , ball-race, pivot						2	—	B.	
27S/134	SKEFKO 400014	BEARING , ball-race, in levers						3	—	B.	
	K.00343	PIECE , distance, between ball-race bearings ...						1	—		EC.1
26FV/3260	K.00344A	LEVER , rudder control						1	—	B.	EC.1
27S/137	SKEFKO I.123630	BEARING , ball-race						2	—	B.	
27S/134	SKEFKO 400014	BEARING , ball-race						2	—	B.	
	K.00342	PIECE , distance, between ball-race bearings ...						1	—		EC.1
26FC/3270	K.00559A	PLATE , link, elevator, for bungee connector, Starboard						1	—	C.	EC.1
		Attaching parts for K.00559A, Plate :—									
28D/13360	A30/7E	Bolt, 1/4" BSF						1	—	C.	
28M/12930	A27/ES	Nut, 1/4" BSF						1	—	C.	
28P/12462	SP.9/C8	Pin, split						1	—	C.	
26FC/2597	J.00260A	ROD , connecting						1	—	B.	EC.1
26FC/2598	J.00267	FORK-END						1	—	C.	EC.1
28L/13028	A.27/JT	LOCKNUT , 3/8" BSF						1	—	C.	

CONTROLS

FLYING CONTROLS IN BOOMS

Ref. No.	Part No.	Nomenclature						No. Off	M.R.	Cl. of St.	Plate No.
		1	2	3	4	5	6				
27S/142	J.00266A SKEFKO. I.132498	ROD , connecting						1	—		EC.1
		BEARING , ball-race						1	—	B.	
		Attaching parts for J.00260A, Rod :—									
28M/13375	A27/GP	Nut, $\frac{1}{16}$ " BSF						1	—	C.	
28M/13122	A27/GS	Nut, $\frac{1}{16}$ " BSF						1	—	C.	
28P/12462	SP.9/C8	Pin, split						1	—	C.	
26FC/3273	K.00360	Spigot						1	—	C.	EC.1
28W/12254	SP.13/G	Washer						1	—	C.	
28W/12667	SP.18/G	Washer						1	—	C.	
26FC/3275	K.00361	SPINDLE , for control levers						1	—	C.	EC.1
		Attaching parts for K.00361, Spindle :—									
28M/13123	A27/JS	Nut, $\frac{3}{8}$ " BSF						2	—	C.	
28P/12462	SP.9/C8	Pin, split						2	—	C.	
28W/12257	SP.13/N	Washer						2	—	C.	
	12 CF 465ND	TUBE , distance, between rudder control lever and support bracket in Port boom						1	—		EC.1
26FC/3276	J.00238	WASHER , between control levers						1	—	C.	EC.1
		Attaching parts for 12 CF 1031A/1 and 12 VF 1033A/1, Brackets :—									
28D/12542	A25/5E	Bolt, $\frac{1}{4}$ " BSF sides						6	—	C.	
28D/12520	A25/4E	Bolt, $\frac{1}{4}$ " BSF top and bottom						2	—	C.	
28M/12928	A27/EP	Nut, $\frac{1}{4}$ " BSF						8	—	C.	
28W/12253	SP.13/E	Washer						8	—	C.	
	—	BRACKET , complete with levers, bottom (See Aerofoils, Fin and Boom)						—	—		
	12 CF 435A	BRACKET , complete with pulleys and levers, top, Port boom						1	—		EC.1
28D/12627	A25/11B	BOLT , 4 BA						1	—	C.	
224	12 CF 29	BRACKET						1	MR	C.	EC.1
26FC/3262	K.00469A	LEVER , rudder control						1	—	B.	EC.1
27S/143	SKEFKO I.132499	BEARING , ball-race, bottom						1	—	B.	
27S/134	SKEFKO 400014	BEARING , ball-race, centre						1	—	B.	
27S/135	SKEFKO I.132629	BEARING , ball-race, top						1	—	B.	
	K.00454	BUSH , bottom, ball-race bearing						2	—		EC.1
28M/12930	A27/ES	NUT , $\frac{1}{4}$ " BSF						2	—	C.	
28P/12462	SP.8/C8	PIN , split						1	—	C.	
26FC/3241	K.00371A	PLATE , cable guard, L.H.						1	—	C.	EC.1
26FC/3242	K.00372	PLATE , cable guard, R.H.						1	—	C.	EC.1
28R/13514	AS.103	PULLEY , elevator trim cables						2	—	A.	EC.1
26FC/3239	K.00364	SPINDLE , for pulleys and levers						1	—	C.	EC.1
	K.00374ND	TUBE , cable guide						1	—		
	AS.2811/8/025	TUBE , distance						1	—		
28W/12321	SP.15/J	WASHER						1	—	C.	
		Attaching parts for 12 CF 435A, Bracket :—									
28D/12674	A25/9E	Bolt, $\frac{1}{4}$ " BSF						4	—	C.	
28M/12928	A27/EP	Nut, $\frac{1}{4}$ " BSF						2	—	C.	
28W/12253	SP.13/E	Washer						4	—	C.	

FLYING CONTROLS IN BOOMS

Ref. No.	Part No.	Nomenclature						No. Off	M.R.	Cl. of St.	Plate No.
		1	2	3	4	5	6				
7702	12 CF 27A	BRACKET , complete with pulleys and levers, top, Starboard boom						1	M.R.	B.	EC.1
224	12 CF 29	BRACKET						1	M.R.	B.	EC.1
26FC/3265	K.00472A	LEVER , elevator control						1	—	B.	EC.1
27S/143	SKEFKO I.132499	BEARING , ball-race, bottom						1	—	B.	
27S/134	SKEFKO 400014	BEARING , ball-race, centre						1	—	B.	
27S/135	SKEFKO I.132629	BEARING , ball-race, top						1	—	B.	
26FC/3262	K.00469A	LEVER , rudder control						1	—	B.	
27S/143	SKEFKO I.132499	BEARING , ball-race, bottom						1	—	B.	
27S/134	SKEFKO 400014	BEARING , ball-race, centre						1	—	B.	
27S/135	SKEFKO I.132629	BEARING , ball-race, top						1	—	B.	
	K.00454	BUSH , bottom, ball-race, bearing						2	—		EC.3
28M/12930	A27/ES	NUT , 1/4" BSF						2	—	C.	
	K.00375	PIECE , distance... ..						1	—		EC.1
28P/12462	SP.9/C8	PIN , split						2	—	C.	
26FC/3239	K.00364	SPINDLE , for levers						1	—	C.	EC.1
Attaching parts for 12 CF 27A, Bracket :—											
28D/12674	A25/9E	Bolt, 1/4" BSF						4	—	C.	
28M/12928	A27/EP	Nut, 1/4" BSF						2	—	C.	
28W/12253	SP.13/E	Washer						4	—	C.	
26FC/3243	K.00377A	BRACKET , complete with pulleys, for elevator trim control, between fin ribs, in Port boom						1	—	C.	EC.1
28D/11804	AS.2504/11E	BOLT , 1/4" BSF						1	—	C.	
26FC/3620	K.00335A	BRACKET						1	—	C.	EC.1
	K.00378	GUARD , cable						1	—		EC.1
28M/19230	A27/ES	NUT , 1/4" BSF						1	—	C.	
26FC/2495	K.00336A	PULLEY , cable						2	—	C.	EC.1
28W/12253	SP.13/E	WASHER						1	—	C.	
3531	K.00569ND	WASHER , under bolt head						1	—	C.	
Attaching parts for K.00377A, Bracket :—											
28D/12531	A25/3C	Bolt, 2 BA						3	—	C.	
28D/12532	A25/4C	Bolt, 2 BA						3	—	C.	
28M/12929	A27/CP	Nut, 2 BA						3	—	C.	
28W/12252	SP.13/C	Washer						3	—	C.	
	12 CF 453A	CABLE , elevator control, lower, Starboard						1	—		EC.1
Attaching parts for 12 CF 453A, Cable :—											
28D/12633	A25/7E	Bolt, 1/4" BSF						1	—	C.	
28M/12930	A27/ES	Nut, 1/4" BSF						1	—	C.	
28P/12462	SP.9/C8	Pin, split						1	—	C.	
	12 CF 451A	CABLE , elevator control, top, Starboard						1	—		EC.1
Attaching parts for 12 CF 451A, Cable :—											
28D/12816	A25/7G	Bolt, 5/16" BSF						1	—	C.	
28M/13122	A27/GS	Nut, 5/16" BSF						1	—	C.	
28P/12462	SP.9/C8	Pin, split						1	—	C.	
2739	12 CF 198A	CABLE , elevator trim, lower, Port						1	M.R.	C.	EC.1
404	12 CF 203A/ND	CABLE , forward						1	—	C.	
26FC/3681	K.00493A/ND	CABLE , rear						1	—	C.	
28P/828	SP4Y/B2	PIN , shackle						1	—	C.	
28P/12587	SP.9/C4	PIN , split						1	—	C.	

CONTROLS

FLYING CONTROLS IN BOOMS

Ref. No.	Part No.	Nomenclature						No. Off	M.R.	Cl. of St.	Plate No.
		1	2	3	4	5	6				
2738	12 CF 197A	CABLE , elevator trim, upper, Port						1	M.R.	C.	EC.1
403	12 CF 199A/ND	CABLE , forward						1	—	C.	
26FC/3679	K.00489A/ND	CABLE , rear						1	—	C.	
28P/828	SP.4Y/B2	PIN , shackle						1	—	C.	
28P/12587	SP.9/C4	PIN , split						1	—	C.	
26FC/3248	K.00453A Mk. 25	CABLE , rudder control, lower						1	—	C.	EC.1
		Attaching parts for K.00453A Mk. 25, Cable :—									
28D/12817	A25/8G	Bolt, $\frac{1}{8}$ " BSF						1	—	C.	
28M/13122	A27/GS	Nut, $\frac{1}{8}$ " BSF						1	—	C.	
28P/12462	SP.9/C8	Pin, split						1	—	C.	
26FC/3250	K.00453A Mk. 26	CABLE , rudder control, top						1	—	C.	EC.1
		Attaching parts for K.00453A Mk. 26, Cable :—									
28D/12544	A25/8E	Bolt, $\frac{1}{4}$ " BSF						1	—	C.	
28M/12930	A27/ES	Nut, $\frac{1}{4}$ " BSF						1	—	C.	
28P/12462	SP.9/C8	Pin, split						1	—	C.	
26FC/2692	K.00406A	CORD , elastic, for elevator control, in Starboard boom						1	—	C.	EC.1
26FC/3253	K.00263	FAIRLEAD , rudder operating cables, front, Port boom						1	—	C.	EC.1
26FC/3254	K.00264	FAIRLEAD , elevator and rudder operating cables, front, Starboard boom						1	—	C.	EC.1
26FC/3252	K.00258	FAIRLEAD , operating cables, intermediate						1	—	C.	EC.1
26FC/3328	K.00259	FAIRLEAD , operating cables, rear						1	—	C.	EC.1
		Attaching parts for K.00263, K.00264, K.00258 and K.00259, Fairleads :—									
28D/12518	A25/2E	Bolt, $\frac{1}{4}$ " BSF						2	—	C.	
26FC/3967	K.00579	FAIRLEAD , elevator trim cable guide, front, in Starboard boom						1	—	C.	
26FC/3966	K.00577	FAIRLEAD , elevator trim cable guide, intermediate, in Starboard boom						1	—	C.	EC.1
26FC/3257	K.00262	FAIRLEAD , elevator trim cable guide, rear, in Starboard boom						1	—	C.	EC.1
		Attaching parts for K.00579, K.00577 and K.00262, Fairleads :—									
28D/12513	A25/2C	Bolt, 2 BA						2	—	C.	
26FC/4700	J.001793A	LEVER , rudder operating, at bottom of rudder torque tube						1	—	B.	EC.1
27S/143	SKEFKO I.132499	BEARING , ball-race						1	—	B.	
27S/134	SKEFKO 400014	BEARING , ball-race						1	—	B.	
		Attaching parts for J.001793A, Lever :—									
26FC/4036	J.001791	Bolt, $\frac{1}{4}$ " BSF, 1.12" long						1	—	C.	EC.1
26FC/4037	J.001791 Mk. 2	Bolt, $\frac{1}{4}$ " BSF, 1.55" long						1	—	C.	EC.1
28M/12930	A27/ES	Nut, $\frac{1}{4}$ " BSF						2	—	C.	
28P/12462	SP.9/C8	Pin split						2	—	C.	
28W/12253	SP.13/E	Washer						2	—	C.	
28L/12931	A.27/ET	LOCKNUT , $\frac{1}{4}$ " BSF, thin, for tension rods						6	—	C.	
28L/13824	A.27/ETL	LOCKNUT , $\frac{1}{4}$ " BSF, thin, L.H. thread, for tension rods						6	—	C.	
28M/12930	A27/ES	NUT , $\frac{1}{4}$ " BSF, slotted, for rudder balance lever link Plates attaching bolt						1	—	C.	

FLYING CONTROLS IN BOOMS

Ref. No.	Part No.	Nomenclature						No Off	M.R.	Cl. of St.	Plate No.
		1	2	3	4	5	6				
28M/13122	A27/GS	NUT , $\frac{5}{16}$ " BSF, slotted, for rudder operating lever connecting rod attaching bolt						1	—	C.	
28P/12462	SP.9/C8	PIN , split, for rudder balance lever link plates and connecting rod attaching nuts, and stop pins						6	—	C.	
7712	12 CF 463	PLATE , link, elevator lever, in Starboard boom ...						4	MR	C.	EC.1
26FC/3269	K.00376	PLATE , link, rudder lever ...						4	—	C.	EC.1
Attaching parts for 12 CF 463 and K.00376, Plates :—											
28D/13262	A20/6E	Bolt, $\frac{1}{4}$ " BSF ...						2	—	C.	
28M/12930	A27/ES	Nut, $\frac{1}{4}$ " BSF ...						2	—	C.	
28P/12462	SP.9/C8	Pin, split ...						2	—	C.	
28W/12253	SP.13/E	Washer ...						2	—	C.	
2872	12 CF 795A	ROD , elevator control, Starboard ...						1	—	C.	
1740	12 CF 459	FORK-END ...						1	—	C.	
28M/13326	A/27GT	LOCKNUT , $\frac{5}{16}$ " BSF ...						1	—	C.	
Attaching parts for 12 CF 795A, Rod :—											
28D/13262	A30/6E	Bolt, $\frac{1}{4}$ " BSF, bottom ...						1	—	C.	
28D/13263	A30/10G	Bolt, $\frac{5}{16}$ " BSF, top ...						1	—	C.	
28M/12930	A27/ES	Nut, $\frac{1}{4}$ " BSF, bottom ...						1	—	C.	
28M/13122	A27/GS	Nut, $\frac{5}{16}$ " BSF, top ...						1	—	C.	
28P/12462	SP.9/C8	Pin, split ...						2	—	C.	
28U/4054	SP8Y/4	ROD , tension, for elevator and rudder cables ...						4	—	C.	
26FC/3274	J.00875	SPIGOT , connecting rudder hinge bracket to lever...						1	—	C.	EC.1
Attaching parts for J.00875, Spigot :—											
28M/13375	A27/GP	Nut, $\frac{5}{16}$ " BSF ...						1	—	C.	
28M/13122	A27/GS	Nut, $\frac{5}{16}$ " BSF ...						1	—	C.	
28P/12462	SP.9/C8	Pin, split ...						1	—	C.	
28W/12254	SP.13/G	Washer ...						1	—	C.	
28W/12267	SP.18/G	Washer, reduce to $\frac{7}{8}$ " o/d ...						1	—	C.	
1895	12 CF 725A	SUPPORT , elevator elastic cord anchorage, Starboard boom						1	—	C.	EC.1

FLYING CONTROLS IN FUSELAGE

Ref. No.	Part No.	Nomenclature						No. Off	M.R.	Cl. of St.	Plate No.
		1	2	3	4	5	6				
		FLYING CONTROLS IN FUSELAGE (12 CF 3)						1	—		ED.1
26FC/1661	—	BRACKET , aileron pulley and torque lever, L.H. ...						1	—	B.	ED.2
28M/13375	K.0091A	NUT , $\frac{5}{16}$ " BSF ...						1	—	C.	
	A27/GP	NUT , $\frac{5}{16}$ " BSF, slotted ...						1	—		ED.2
	K.00593	(Make from Part No. A27/GS, Ref. No. 28M/13122)									
28P/12462	SP.9/C8	PIN , split ...						1	—	C.	
28R/13515	AS.104	PULLEY , aileron cable ...						1	—	B.	
26FC/1653	K.0077	SPINDLE , for pulley ...						1	—	C.	ED.2
26FC/3491	K.0075	STUD , cable guard ...						2	—	C.	ED.2
28W/12254	SP.13/G	WASHER ...						2	—	C.	
		Attaching parts for K.0091A, Bracket :—									
28D/12716	A.25/16E	Bolt, $\frac{1}{4}$ " BSF ...						4	—	C.	
28M/12928	A27/EP	Nut, $\frac{1}{4}$ " BSF ...						4	—	C.	
26BY/5720	DHS.34/D	Washer, $\frac{1}{4}$ " BSF ...						4	—	C.	
26BY/2856	DHS.33 Mk. 2	Washer, $\frac{1}{4}$ " BSF, shrinkage ...						8	—	C.	
324	12 CF 293	BRACKET , cable seal and hydraulic units mounting, on bulkhead No. 2, L.H.						1	M.R.	C.	ED.1
		Attaching parts for 12 CF 293, Bracket :—									
28D/12538	A25/15C	Bolt, 2 BA ...						4	M.R.	C.	
28D/13105	A25/26C	Bolt, 2 BA ...						2	M.R.	C.	
28D/8317	AS.1242/15C	Bolt, 2 BA ...						1	M.R.	C.	
28M/12929	A27/CP	Nut, 2 BA ...						7	M.R.	C.	
	Q.002603	Shim, under bracket ...						1	M.R.	C.	
26BY/5871	DHS.34/C	Washer, 2 BA ...						6	M.R.	C.	
26BY/3165	DHS.33 Mk. 1	Washer, 2 BA, shrinkage ...						12	M.R.	C.	
28W/12252	SP.13/C	Washer ...						7	M.R.	C.	
323	12 CF 291	BRACKET , cable seal, on bulkhead No. 2, R.H.						1	M.R.	C.	ED.1
		Attaching parts for 12 CF 291, Bracket :—									
28D/12538	A25/15C	Bolt, 2 BA ...						9	M.R.	C.	
28D/12985	A25/25C	Bolt, 2 BA ...						2	M.R.	C.	
28M/12929	A27/CP	Nut, 2 BA ...						11	M.R.	C.	
26FC/4008	K.00906	Shim, under bracket ...						1	M.R.	C.	
26BY/5871	DHS.34/C	Washer, 2 BA ...						12	M.R.	C.	
26BY/3165	DHS.33 Mk. 1	Washer, 2 BA, shrinkage ...						24	M.R.	C.	
28W/12252	SP.13/C	Washer ...						12	M.R.	C.	
7110	12 CF 445A	BRACKET , control pulley aft of bulkhead No. 3, L.H.						1	M.R.	B.	ED.3
	12 CF 75A	BRACKET , mounting ...						1	M.R.		ED.3
28D/12566	A25/6C	BOLT , 2 BA ...						1	—	C.	
28D/8323	AS.1242/2E	BOLT , $\frac{1}{4}$ " BSF ...						1	M.R.	C.	
400	12 CF 83	GUARD , cable ...						1	—	C.	ED.3
28M/10288	AGS.2001/C/1	NUT , 2 BA ...						1	—	C.	
28M/13123	A27/JS	NUT , $\frac{3}{8}$ " BSF ...						1	M.R.	C.	
	12 CF 89ND	PIN , locking, $\frac{3}{32}$ " dia. x 0-6" long, S.1 ...						1	—		ED.3
402	12 CF 85A	PULLEY , rudder cable ...						1	M.R.	C.	ED.3
	K.00553	SPINDLE , for pulley ...						1	M.R.		ED.3
26FC/1686	K.00238	TUBE , distance ...						1	—	C.	
6665	12 CF 447A	BRACKET , control pulleys aft of bulkhead No. 3, R.H.						1	M.R.	B.	ED.3
	12 CF 76A	BRACKET , mounting ...						1	M.R.		ED.3
28D/12566	A25/6C	BOLT , 2 BA ...						2	—	C.	
28D/8323	AS.1242/2E	BOLT , $\frac{1}{4}$ " BSF ...						1	M.R.	C.	

FLYING CONTROLS IN FUSELAGE

Ref. No.	Part No.	Nomenclature						No. Off	M.R.	Cl. of St.	Plate No.
		1	2	3	4	5	6				
1504	12 CF 499	CABLE , aileron balance						1	—	C.	ED.1
854	12 CF 339A	CABLE , aileron operating, from joint near control column to joint on rib No. 1, L.H.						1	—	C.	ED.1
6489	12 CF 957A	CABLE , aileron operating, complete with chain, R.H.						1	—	C.	ED.1
855	12 CF 347A	CABLE , elevator operating, lower, from quadrant to joint on rib No. 1, Starboard						1	—	C.	ED.1
Attaching parts for 12 CF 347A, Cable :—											
28D/9435	AS.1242/8E	Bolt, 1/4" BSF						2	—	C.	
26FC/3750	K.0088/1	Clamp, cable to pulley						1	—	C.	ED.1
28M/12930	A.27/ES	Nut, 1/4" BSF						2	—	C.	
28P/12462	SP.9/C8	Pin, split						2	—	C.	
	K.00575	Washer, spacer						1	—		
28W/12253	SP.13/E	Washer						1	—	C.	
852	12 CF 343A	CABLE , elevator operating, upper, from quadrant to joint on rib No. 1, Starboard						1	—	C.	ED.1
Attaching parts for 12 CF 343A, Cable :—											
28D/8310	AS.1242/6C	Bolt, 2 BA						1	—	C.	
28D/9436	AS.1242/8G	Bolt, 5/16" BSF						1	—	C.	
26FC/3749	K.0087/1	Clamp, cable to pulley						1	—	C.	ED.1
28M/13121	A27/CS	Nut, 2 BA						1	—	C.	
28M/13122	A27/GS	Nut, 5/16" BSF						1	—	C.	
28P/12462	SP.9/C8	Pin, split						2	—	C.	
28W/12252	SP.13/C	Washer						1	—	C.	
28W/12254	SP.13/G	Washer						1	—	C.	
856	12 CF 355A	CABLE , rudder balance						1	—	C.	ED.1
853	12 CF 351A	CABLE , rudder operating, from pedals to joint on rib No. 1						2	—	C.	ED.1
Attaching parts for 12 CF 351A, Cable :—											
26FC/1682	K.00237	Bolt						1	—	C.	ED.1
26FC/1668	K.00193	Collar, bearing						1	—	C.	ED.1
28M/13122	A27/GS	Nut, 5/16" BSF						1	—	C.	
28P/12462	SP.9/C8	Pin, split						1	—	C.	
28W/12254	SP.13/G	Washer						1	—	C.	
26FC/1651	K.00203	CAP , control column sump drain						1	—	C.	ED.1
9027	12 CF 789	CLIP , retaining, brake control in cockpit						1	MR	C.	ED.1
9028	12 CF 791	CLIP , retaining, small, brake control in cockpit						1	MR	C.	ED.1
Attaching parts for 12 CF 789 and 12 CF 791, Clips :—											
28D/11540	AS.1246/2B	Bolt, 4 BA						2	—	C.	
28M/10287	AGS.2001/B/1	Nut, 4 BA						2	—	C.	
28W/12305	SP.13/B	Washer						2	—	C.	
	12 CF 1003A/2	COLUMN , control (See Separate Unit)						1	—		EE.1
Attaching parts for 12 CF 1003A/2, Column :—											
28D/12531	A25/3C	Bolt, 2 BA						12	—	C.	
28M/13121	A27/CS	Nut, 2 BA						12	—	C.	
28P/12462	SP.9/8	Pin, split						12	—	C.	
28W/12252	SP.13/C	Washer						12	—	C.	
7703	12 CF 335	FAIRLEAD , cable, aft, at control pulleys aft of bulkhead No. 3, Port						1	MR	C.	ED.3
7704	12 CF 336	FAIRLEAD , cable, aft, at control pulleys aft of bulkhead No. 3, Starboard						1	MR	C.	ED.3

CONTROLS

FLYING CONTROLS IN FUSELAGE

Ref. No.	Part No.	Nomenclature						No. Off	M.R.	Cl. of St.	Plate No.
		1	2	3	4	5	6				
7705	12 CF 337	FAIRLEAD , cable, forward, at control pulleys aft of bulkhead, No. 3, Port						1	MR	C.	ED.3
7706	12 CF 338	FAIRLEAD , cable, forward, at control pulleys aft of bulkhead No. 3, Starboard						1	MR	C.	ED.3
26FC/11542	K.00269A/1	GAITER , dust excluder, at base of control column						1	—	C.	ED.1
		Attaching parts for K.00269A/1, Gaiter :—									
28D/12538	A25/15C	Bolt, 2 BA						5	—	C.	
28D/12631	A25/23C	Bolt, 2 BA						1	—	C.	
28M/12929	A27/CP	Nut, 2 BA						6	—	C.	
26BY/5871	DHS.34/C	Washer, 2 BA						6	—	C.	
26BY/3165	DHS.33 Mk. 1	Washer, 2 BA, shrinkage						12	—	C.	
26FC/3022	K.00550A	GUARD , cable, at elevator quadrant, R.H.						1	—	C.	ED.3
		Attaching parts for K.00550A, Guard :—									
28D/12512	A25/1C	Bolt, 2 BA						2	—	C.	
28W/12252	SP.13/C	Washer						1	—	C.	
26FC/1657	K.00271A	GUARD , aileron cable seal, at bottom of control column						2	—	C.	ED.1
		Attaching parts for K.00271A, Guard :—									
28D/12538	A25/15C	Bolt, 2 BA						2	—	C.	
28M/12929	A27/CP	Nut, 2 BA						2	—	C.	
26BY/5871	DHS.34/C	Washer, 2 BA						2	—	C.	
26BY/3165	DHS.33 Mk. 1	Washer, 2 BA, shrinkage						4	—	C.	
	12 CF 1051	GUARD , for sprocket and chain for powered ailerons on cockpit floor, Starboard						1	—		ED.2
		Attaching parts for 12 CF 1051, Guard :—									
28L/11067	AGS.2035/B	Lockwasher						1	—	C.	
28S/2863	A32/B16	Screw						1	—	C.	
6527	12 CF 627	GUARD , chain for aileron sprocket						2	—	C.	ED.2
26FC/1647	K.00298	LEVER , on brake differential unit						1	—	C.	ED.1
		Attaching parts for K.00298, Lever :—									
28D/12629	A25/8C	Bolt, 2 BA						1	—	C.	
28M/13121	A27/CS	Nut, 2 BA						1	—	C.	
28P/12462	SP.9/C8	Pin, split						1	—	C.	
28W/12252	SP.13/C	Washer						2	—	C.	
28N/9796	SP/21	NIPPLE , grease, at cable seals on bulkhead No. 2						4	—	C.	
		PEDAL , rudder, arrangement (K.005) (See Separate Unit)						1	—		EF.1
26FC/1643	Q.0099	PLATE , mounting, brake differential unit						1	—	C.	
		Attaching parts for Q.0099, Plate :—									
28D/12512	A25/1C	Bolt, 2 BA						7	—	C.	ED.1
28M/10288	AGS.2001/C/1	Nut, 2 BA						7	—	C.	
28W/12252	SP.13/C	Washer						7	—	C.	

FLYING CONTROLS IN FUSELAGE

Ref. No.	Part No.	Nomenclature						No Off	M,R.	Cl. of St.	Plate No.
		1	2	3	4	5	6				
26FC/1642	Q.00598A	PLATE , seal, at hand pump bracket						1	—	A.	ED.1
27W/7	LOCKHEED UMC.703	VALVE , non-return						1	—	A.	ED.1
28W/1049	UMC.723	SPRING						1	—	C.	ED.1
28W/1050	UMC.722	UNION						1	—	C.	ED.1
28F/10463	AGS.1139/C	WASHER , jointing						1	—	C.	
28R/13515	AS.104	PULLEY , cable, on bulkhead No. 2						2	—	B.	ED.2 ED.3
28D/12642	A25/71	Attaching parts for AS.104, Pulley :— Bolt, 3/8" BSF						1	—	C.	
28M/13123	A27/JS	Nut, 3/8" BSF						1	—	C.	
28P/12462	SP.9/C8	Pin, split						1	—	C.	
28W/12255	SP.13/J	Washer						1	—	C.	
	12 CF 1053A	QUADRANT , pulley, elevator control, R.H.						1	—		ED.3
		(Mod. Ven. 504)									
27S/48	SKEFKO EE.3	BEARING , ball-race						1	—	B.	
27S/49	SKEFKO EE.4	BEARING , ball-race						1	—	B.	
	K.0068	BRACKET , mounting, R.H.						1	—		ED.3
	12 CF 1069ND	DISC , stop (Mod. Ven. 504)						1	—		ED.3
		Attaching parts for 12 CF 1069ND, Disc :—									
28D/9435	AS.1242/8E	Bolt, 1/2" BSF						1	—	C.	
28M/13534	A27/EC	Nut, 1/2" BSF						1	—	C.	
28P/12462	SP.9/C8	Pin, split						1	—	C.	
28W/12253	SP.13/E	Washer						1	—	C.	
26FC/1632	K.0079	GUARD , block						1	—	C.	ED.3
		Attaching parts for K.0079, Guard :—									
	K.00973ND	Bolt, 1/2" BSF (Make from Part No. A25/28E, Ref. No. 28D/12637)						1	—		ED.3
26FC/1635	K.0063	PLATE , ball-race bearing cover						1	—	C.	ED.3
		Attaching parts for K.0063, Plate :—									
28S/2815	A33/B16	Screw, 4 BA						6	—	C.	
26FC/4392	K.00588A	PLATE , cable attachment, front, R.H.						1	—	C.	ED.3
26FC/4394	K.00590A	PLATE , cable attachment, rear, R.H.						1	—	C.	ED.3
		Attaching parts for K.00588A and K.00590A, Plates (per pair) :—									
28D/8328	AS.1242/7E	Bolt, 1/2" BSF						2	—	C.	
28L/12931	A.27/ET	Locknut, 1/2" BSF						1	—	C.	
28M/12928	A27/EP	Nut, 1/2" BSF						1	—	C.	
26FC/1638	K.0062	PULLEY , quadrant						1	—	C.	ED.3
26FC/1634	K.0069	SPINDLE , for pulley						1	—	C.	ED.3
		Attaching parts for K.0069, Spindle :—									
28D/8311	AS.1242/7C	Bolt, 2 BA						6	—	C.	
28M/12929	A27/CP	Nut, 2 BA						6	—	C.	
28M/12930	A27/ES	Nut, 1/2" BSF						1	—	C.	
28P/12462	SP.9/C8	Pin, split						1	—	C.	
26FC/1803	K.0041	Washer, shouldered						1	—	C.	ED.3
28W/12252	SP.13/C	Washer						6	—	C.	

FLYING CONTROLS IN FUSELAGE

Ref. No.	Part No.	Nomenclature						No. Off	M.R.	Cl. of St.	Plate No.
		1	2	3	4	5	6				
26FC/1633	K.0076	TUBE , spacer, between ball-race bearings ...						1	—	C.	ED.3
		Attaching parts for 12 CF 1053A, Quadrant :—									
28D/12546	A25/14E	Bolt, $\frac{3}{8}$ " BSF ...						4	—	C.	
28M/12928	A27/EP	Nut, $\frac{3}{8}$ " BSF ...						4	—	C.	
26BY/5720	DHS.134/D	Washer, $\frac{3}{8}$ " BSF ...						4	—	C.	
26BY/2856	DHS.33 Mk. 3	Washer, $\frac{3}{8}$ " BSF, shrinkage ...						8	—	C.	
26FC/1630	K.00302A	ROD , connecting, brake differential unit ...						1	—	C.	ED.1
28N/10619	AGS.385/B	BALL , actuating ...						2	—	C.	
28L/12931	A.27/ET	LOCKNUT , $\frac{3}{8}$ " BSF ...						3	—	C.	
28L/13454	A.27/ETL	LOCKNUT , $\frac{3}{8}$ " BSF, L.H. thread ...						1	—	C.	
28P/12462	SP.9/C8	PIN , split ...						2	—	C.	
28N/13078	AGS.385/C	PLUG , screwed ...						2	—	C.	
26FC/1631	K.00300	SOCKET , L.H. thread ...						1	—	C.	ED.1
28N/10377	AGS.385/A	SOCKET , R.H. thread ...						1	—	C.	
26FC/1629	K.0093A	ROD , connecting, elevator torque lever to quadrant ...						1	—	B.	ED.2
26FC/1652	K.0082A	EYE-END ...						1	—	B.	ED.2
26BY/4552	SKEFKO	BEARING , ball-race ...						1	—	B.	
	400602/C-001										
28M/10623	AGS.759/G	NUT , $\frac{7}{16}$ " BSF ...						1	—	C.	
		Attaching parts for K.0093A, Rod :—									
26FC/1663	K.00285	Bolt, at quadrant ...						1	—	C.	ED.2
26FC/1662	K.00284	Bolt, at torque lever ...						1	—	C.	ED.2
28M/8101	AGS.572/C	Nut, $\frac{5}{16}$ " BSF ...						2	—	C.	
28P/12462	SP.9/C8	Pin, split ...						2	—	C.	
26FC/1623	K.00283	Washer, dust excluder, at quadrant ...						1	—	C.	ED.2
26FC/1622	K.00267	Washer, shouldered, at torque lever ...						2	—	C.	ED.2
26FC/1644	K.00280	Washer, spacer, at quadrant ...						1	—	C.	ED.2
28W/12254	SP13/G	Washer ...						2	—	C.	
26FC/2335	K.00528	SCREW , grub, for locking cables seal on bulkhead No. 2 ...						4	—	C.	
	—	SEAL , cable, on bulkhead No. 2 ...						8	—	C.	
26BY/14435	SEEGER	CIRCLIP , internal, for $\frac{3}{8}$ " dia. bore ...						1	—	C.	
26FC/1672	K.00214	FERRULE , housing, for sealing washers ...						1	—	C.	ED.2
26FC/1665	K.00217	WASHER , half, for sealing washers ...						4	—	C.	ED.2
26BY/14433	K.98646	WASHER , sealing ...						8	—	C.	ED.2
26BY/14434	K.98647	WASHER , sealing ...						4	—	C.	ED.2
6529	12 CF 617	SPINDLE , for aileron sprocket ...						1	—	C.	ED.2
		Attaching parts for 12 CF 617, Spindle :—									
28L/13028	A27/JT	Locknut ...						1	—	C.	
28M/13289	A27/JC	Nut, $\frac{3}{8}$ " ...						1	—	C.	
28P/12462	SP.9/C8	Pin, split ...						1	—	C.	
28W/12255	SP13/J	Washer ...						1	—	C.	
6530	12 CF 907A	SPROCKET , aileron spring strut ...						1	—	B.	ED.2
27S/135	SKF.CBS.3	BEARING ...						2	—	B.	
	12 CF 909	LEVER , bearing ...						1	—	C.	ED.2
		Attaching parts for 12 CF 909, Lever :—									
28D/12513	A25/2C	Bolt, 2 BA ...						5	—	C.	
28M/12929	A27/CP	Nut, 2 BA ...						5	—	C.	
28W/12252	SP13/C	Washer ...						5	—	C.	

FLYING CONTROLS IN FUSELAGE

Ref. No.	Part No.	Nomenclature						No. Off	M.R.	Cl. of St.	Plate No.
		1	2	3	4	5	6				
6531	12 CF 911	SPROCKET						1	—	C.	ED.2
	12 CF 935	TUBE , distance						1	—		ED.2
4744	12 CF 885A	STRUT , spring, aileron						1	—	A.	ED.2
4748	12 CF 891	BUSH						2	—	C.	ED.2
4745	12 CF 895A	BEARING-END						1	—	B.	ED.2
27S/143	SKEFKO I.132499	BALL-RACE						1	—	B.	
28R/13507	HOFFMANN CF.2A	BEARING , eye-end						1	—	A.	
4750	12 CF 619	CAP , screw						1	—	C.	ED.2
	12 CF 887	HOUSING , spring strut						1	—		ED.2
	12 CF 955	LABEL , " TO PORT-TRIM AILERON-TO STARBOARD "						1	—		ED.2
28L/13326	A27/GT	LOCKNUT , rod-end						1	—	C.	
4746	12 CF 899	RING , retaining bearing end						1	—	C.	ED.2
4751	12 CF 903	SHIM , screw cap						1	—	C.	ED.2
	12 CF 893	SLEEVE						1	—		ED.2
		Attaching parts for 12 CF 893, Sleeve :—									
28S/2857	A32/B12	Screw, 4 BA						3	—	C.	
4749	12 CF 889	SPINDLE						1	—	C.	ED.2
		Attaching parts for 12 CF 889, Spindle :—									
28M/13122	A27/GS	Nut, $\frac{5}{16}$ " BSF						1	—	C.	
28P/12462	SP.9/C8	Pin, split						1	—	C.	
28W/12254	SP.13/G	Washer						1	—	C.	
4747	12 CF 905	SPRING						1	—	C.	ED.2
	12 CF 901	STOP , barrel						1	—		ED.2
		Attaching parts for 12 CF 885A, Strut :—									
28D/12566	A25/6C	Bolt, 2 BA						1	—	C.	
28M/13121	A27/CS	Nut, 2 BA						1	—	C.	
28P/12462	SP.9/C8	Pin, split						1	—	C.	
6528	12 CF 611	Spindle						1	—	C.	ED.2
28W/12252	SP.13/C	Washer						1	—	C.	
26FC/1628	K.0046A	SUMP , base of control column						1	—	B.	ED.1
27S/158	SKEFKO I.132358	BEARING , ball-race						1	—	B.	
		Attaching parts for K.0046A, Sump :—									
28D/12538	A25/15C	Bolt, 2 BA						1	—	C.	
28D/12568	A25/22C	Bolt, 2 BA						3	—	C.	
28M/12929	A27/CP	Nut, 2 BA						4	—	C.	
28BY/5871	DHS.34/C	Washer, 2 BA						4	—	C.	
26BY/3165	DHS.33 Mk. 1	Washer, 2 BA, shrinkage						8	—	C.	
	K.00530ND	TUBE , cable guide, for aileron pulleys on bulkhead No. 2, $\frac{3}{8}$ " o/d \times 17 SWG \times 0-6" long, Dural						1	—		
		Attaching parts for K.00530ND, Tube :—									
28D/12674	A25/9E	Bolt, $\frac{1}{4}$ " BSF						1	—	C.	
28M/13534	A27/EC	Nut, $\frac{3}{8}$ " BSF						1	—	C.	
28P/12462	SP.9/C8	Pin, split						1	—	C.	
28W/12253	SP.13/E	Washer						2	—	C.	
	K.00530ND	TUBE , cable guide, for aileron pulleys on bulkhead No. 2, $\frac{3}{8}$ " o/d \times 17 SWG \times 0-6" long, Dural (Mod. Ven. 328)						1	—		
		Attaching parts for K.00530ND, Tube :—									
28D/12569	A25/10E	Bolt, $\frac{1}{4}$ " BSF						1	—	C.	
28M/12928	A27/EP	Nut, $\frac{1}{4}$ " BSF						1	—	C.	
28W/12253	SP.13/E	Washer						2	—	C.	

FLYING CONTROLS IN FUSELAGE

Ref. No.	Part No.	Nomenclature						No Off.	M.R.	Cl. of St.	Plate No.
		1	2	3	4	5	6				
8180	12 CF 1061A	TUBE , stay, elevator quadrant to bulkhead No. 2 Mod. 504)						1	—	C.	ED.1
26FC/5869	K.0084	FORKEND						1	—	C.	ED.1
	12 CF 1065	FORKEND						1	—	C.	ED.1
28M/13295	A27/JP	NUT , $\frac{3}{8}$ " BSF						1	—	C.	
8179	DHS.94/4/90	PIN , retaining						5	—	C.	
		Attaching parts for 12 CF 1061A, Tube :—									
28D/12542	A25/5E	Bolt, $\frac{1}{4}$ " BSF						2	—	C.	
28M/12930	A27/ES	Nut, $\frac{1}{4}$ " BSF						2	—	C.	
28W/12253	SP.13/E	Washer						2	—	C.	
	12 CF 697A	TUBE , torque, elevator lever, L.H.						1	—		ED.1
26FC/1625	K.0098A	TUBE , torque, elevator lever, R.H.						1	—	B.	ED.1
26FC/1806	K.00172	COUPLING , flange						1	M.R.	C.	EE.1
	12 CF 677A	FITTING , end, for bias weight, L.H.						1	—		ED.1
1896	12 CF 695	BOLT , special, securing top and bottom halves						1	—	C.	ED.1
26FC/1645	K.0065A	LEVER , elevator, L.H.						1	M.R.	B.	ED.1
26FC/1646	K.0066A	LEVER , elevator, R.H.						1	M.R.	B.	ED.1
28BY/4552	SKEFKO 400602/C-001	BEARING , ball-race						2	—	B.	
	DHS.94/8/240	PIN , for bias weight end fitting						2	M.R.		
	DHS.94/8/215	PIN , for coupling and lever						4	M.R.		
		Attaching parts for 12 CF 697A and K.0098A, Tubes :—									
26FC/1660	K.0072	Bolt, $\frac{5}{16}$ " BSF						1	—	C.	ED.1
26FC/574	DHS.69/E	Shim, $\frac{1}{16}$ " BSF, L.H. side only						2	—	C.	
27G/2014	DUNLOP AH.8241	VALVE , brake differential						1	—	A.	ED.1
		Attaching parts for AH.8241, Valve :—									
26BY/13445	DHS.12 Mk. 16	Bolt, 2 BA						4	—	C.	
28W/12252	SP.13/C	Washer						4	—	C.	
26FC/1624	AS.119	WASHER , for sump drain cap						1	—	C.	
1877	12 CF 649A	WEIGHT , bias, on elevator torque tube						1	—	C.	ED.1
		Attaching parts for 12 CF 649A, Weight :—									
28D/14642	A30/18E	Bolt, $\frac{1}{4}$ " BSF						3	—	C.	
28M/10290	AGS.2001/E/1	Nut, $\frac{1}{4}$ " BSF						3	—	C.	
28W/12253	SP.13/E	Washer						3	—	C.	

CONTROLS

CONTROL COLUMN

Ref. No.	Part No.	Nomenclature						No Off	M.R.	Cl. of St.	Plate No.
		1	2	3	4	5	6				
9026	12 CF 1003A/2	COLUMN, CONTROL						1	—		EE.1
	12 CF 765	ARM , movable, for handgrip						1	MR	C.	EE.1
		Attaching parts for 12 CF 765, Arm :—									
28M/13123	A27/JS	Nut, 1/2" BSF						1	—	C.	
28P/12462	SP.9/C8	Pin, split						1	—	C.	
26FC/1805	K.0052	Spindle						1	—	C.	EE.1
26FC/1792	K.0053	Washer, bearing						2	—	C.	EE.1
26FC/11767	K.0054	Washer, shouldered						1	—	C.	EE.1
		EF.1									
27S/49	SKEFKO EE.4	BEARING , ball-race, for movable arm						2	—	B.	
2378	DUNLOP	CABLE , brake operating						1	—	C.	
	ACO.6631										
6489	12 CF 957A	CABLE , aileron operating 181-2" 25 cwt.						1	—	C.	EE.1
27KB/107	AS.210/31P	CHAIN , top						1	—	B.	
26FC/1806	K.00172	COUPLING , flanged, for torque tube at bottom of control column						2	MR	C.	EE.1
		Attaching parts for K.00172, Coupling :—									
5281	DHS.94/8/220	Pin						2	MR	C.	
26BY/3551	K.98593	COVER , for nut securing handgrip movable arm						1	—	C.	EE.1
		Attaching parts for K.98593, Cover :—									
28D/12528	A25/1B	Bolt, 4 BA						2	—	C.	
28L/11067	AGS.2035/B	Lockwasher						2	—	C.	
6488	12 CF 939	FITTING , bottom of control column						1	MR	C.	EE.1
		Attaching parts for 12 CF 939, Fitting :—									
	DHS.94/8/235	Pin						3	MR		
	12 CF 753	FITTING , top of control column						1	MR		EE.1
		Attaching parts for 12 CF 753, Fitting :—									
	DHS.94/8/235	Pin						2	MR		
	12 CF 743A	GUARD , cable front						1	—	C.	EE.1
		Attaching parts for 12 CF 743A, Guard :—									
28D/12715	A25/31C	Bolt, 2 BA						1	—	C.	
28D/12518	A25/2E	Bolt, 1/2" BSF						1	—	C.	
28D/12717	A25/31E	Bolt, 1/2" BSF						1	—	C.	
28L/11071	AGS.2035/E	Lockwasher						1	—	C.	
28M/10288	AGS.2001/C/1	Nut, 2 BA						1	—	C.	
28M/12928	A27/EP	Nut, 1/2" BSF						1	—	C.	
28W/12252	SP.13/C	Washer						1	—	C.	
28W/12253	SP.13/E	Washer						1	—	C.	
10299	12 CF 755A	GUARD , cable, rear						1	—	C.	EE.1
		Attaching parts for 12 CF 755A, Guard :—									
28D/8307	AS.1242/2C	Bolt, 2 BA						2	—	C.	
28M/10288	AGS.2001/C/1	Nut, 2 BA						2	—	C.	
28W/12252	SP.13/C	Washer						2	—	C.	
27J/250	DUNLOP	HANDGRIP , Mk. 3, complete						1	—	A.	EE.1
	AC.1400										
	12 CF 1007A/2	QUADRANT , cable, at bottom of control column						1	—		EE.1
28S/48	SKEFKO EE.3	BEARING , ball-race						2	—	B.	
26FC/3682	K.00453A Mk. 22	CABLE , aileron control						2	—	C.	EE.1
		Attaching parts for K.00453A Mk. 22, Cable :—									
28D/12569	A25/10E	Bolt, 1/2" BSF						1	—	C.	
28M/12928	A27/EP	Nut, 1/2" BSF						1	—	C.	

CONTROLS

CONTROL COLUMN

Ref. No.	Part No.	Nomenclature						No. Off	M.R.	Cl. of Se.	Plate No.
		1	2	3	4	5	6				
27KB/120	AS.216/29P							1	—	B.	
26FC/1799	K.0037							1	—	C.	EE.1
26FC/1800	K.0038							1	—	C.	EE.1
26FC/1798	K.0064							1	—	C.	EE.1
28M/12929	A27/CP							1	—	C.	
26FC/1801	K.00231							1	—	C.	EE.1
26FC/1797	K.0040							1	—	C.	EE.1
28M/12930	A27/ES							1	—	C.	
28P/12462	SP.9/C8							1	—	C.	
26FC/11768	K.0042							1	—	C.	EE.1
											EF.1
26FC/1803	K.0041							1	—	C.	EE.1
26FC/1802	K.0039							1	—	C.	EE.1
28D/8331	AS.1242/12E							2	—	C.	
28M/12928	A27/EP							2	—	C.	
28W/12253	SP.13/E							2	—	C.	
26FC/1795	K.0044							1	—	C.	EE.1
28M/13122	A27/GS							1	—	C.	
28P/12462	SP.9/C8							1	—	C.	
28W/12254	SP.13/G							1	—	C.	
26FC/1790	K.0057							1	—	C.	EE.1
28S/2814	A33/C16							4	—	C.	
419	12 CF 41							1	—	C.	
26FC/3492	K.00226							6	—	C.	EE.1
28A/1392	C.105							2	—	C.	EE.1
28L/5234	A14/CB							1	—	C.	
28L/5221	A14/CBL							1	—	C.	
	K.00223							1	—		EE.1
28D/12636	A25/25E							1	—	C.	
28M/12930	A27/ES							1	—	C.	
28P/12462	SP.9/C8							1	—	C.	
28W/12253	SP.13/E							1	—	C.	

RUDDER PEDAL ARRANGEMENT

Ref. No.	Part No.	Nomenclature						No Off	M.R.	Cl. of St.	Plate No.
		1	2	3	4	5	6				
		RUDDER PEDAL ARRANGEMENT (K.005) ...						1	—		EF.1
26FC/1785	K.00908A/ND K.00184	PEDALS , rudder						1	—		EF.1
		BEARING , end plug, of torque tube at centre support bracket						2	MR	C.	EF.1
		Attaching parts for K.00184, Bearing :—									
5281	DHS.94/8/220	Pin						2	MR	C.	
26FC/1773	K.00185	BEARING , end plug, of torque tube at fuselage side						2	MR	C.	EF.1
		Attaching parts for K.00185, Bearing :—									
	DHS.94/8/270	Pin						2	MR		
26FC/1788	K.00171A	BRACKET , centre support						1	—	B.	EF.1
27S/6	SKEFKO RL.4	BEARING , ball-race						3	—	B.	
27S/48	SKEFKO EE.3	BEARING , ball-race						1	—	B.	
26FC/1774	K.00163A	LEVER , operating						1	—	C.	EF.1
27S/143	SKEFKO I.132499	BEARING , ball-race						2	—	B.	
26FC/1789	K.00165	PIECE , distance, between bearings on operating lever pivot pin						1	—	C.	EF.1
26FC/1780	K.00164	PIN , operating lever pivot						1	—	C.	EF.1
26FC/1781	K.00166	PLATE , retaining ball-race bearings						3	—	C.	EF.1
26FC/11768	K.0042	WASHER , operating lever pivot pin						1	—	C.	
26FC/1782	K.00191A	BRACKET , end bearing, L.H.						1	—	B.	EF.1
26FC/1783	K.00192A	BRACKET , end bearing, R.H.						1	—	B.	EF.1
27S/6	SKEFKO RL.4	BEARING , ball-race						1	—	B.	
26FC/1988	K.00299	LEVER , brake operating						1	MR	C.	
		Attaching parts for K.00299, Lever :—									
26FC/6979	DHS.94/8/260	Pin						1	MR	C.	
26FC/1775	K.00199A	LINK , connecting operating lever to torque tube						2	—	B.	EF.1
27S/143	SKEFKO I.132499	BEARING , ball-race						1	—	B.	
		Attaching parts for K.00199A, Link :—									
26FC/1786	K.00198	Bolt, to pedal mounting						1	—	C.	EF.1
28D/12816	A25/7G	Bolt, $\frac{5}{16}$ " BSF, to operating lever						1	—	C.	
28M/13122	A27/GS	Nut, $\frac{5}{16}$ " BSF						2	—	C.	
	K.00188	Piece, distance, $\frac{3}{8}$ " o/d \times 22 SWG \times 0.13" long, T.35 (Make from Ref. No. 30A/1929)						1	—		EF.1
28P/12462	SP.9/C8	Pin, split						2	—	C.	
26FC/1764	K.00167	Washer						2	—	C.	EF.1
26FC/1778	K.00169 Mk. 2	MOUNTING , pedal, L.H. inner						1	MR	C.	EF.1
26FC/1777	K.00169 Mk. 1	MOUNTING , pedal, L.H. outer						1	MR	C.	EF.1
26FC/1772	K.00170 Mk. 2	MOUNTING , pedal, R.H. inner						1	MR	C.	EF.1
26FC/1779	K.00170 Mk. 1	MOUNTING , pedal, R.H. outer						1	MR	C.	EF.1
		Attaching parts for K.00169 Mk. 2, K.00169 Mk. 1, K.00170 Mk. 2 and K.00170 Mk. 1, Mountings :—									
	DHS.94/8/270	Pin						3	MR		
26BY/5976	H.11336	PAD , tread, for pedal						2	—	C.	EF.1
		Attaching parts for H.11336, Pad :—									
28L/13140	A.27/BT	Locknut, 4 BA						2	—	C.	
28S/2869	A32/B20	Screw, 4 BA						2	—	C.	
28W/12306	SP.15/B	Washer						4	—	C.	

RUDDER PEDAL ARRANGEMENT

Ref. No.	Part No.	Nomenclature						No. Off	M.R.	Cl. of St.	Plate No.
		1	2	3	4	5	6				
26FC/1771	K.00183	PEDAL						2	—	C.	EF.1
		Attaching parts for K.00183, Pedal :—									
28D/12817	A25/8G	Bolt, $\frac{5}{16}$ " BSF						2	—	C.	
26FC/1784	K.00168	Collar						2	—	C.	EF.1
28M/13121	A27/CS	Nut, $\frac{3}{4}$ " BSF						2	—	C.	
28P/12462	SP.9/C8	Pin, split						2	—	C.	
26FC/1764	J.00167	Washer, under bolt head						2	—	C.	EF.1
28W/12254	SP.13/G	Washer						2	—	C.	
26FC/1766	K.00186	PIN , pivot, inboard end of torque tube						2	MR	C.	EF.1
		Attaching parts for K.00186, Pin :—									
28L/13028	A.27/JT	Locknut, $\frac{3}{8}$ " BSF... ..						1	MR	C.	
28M/13123	A27/JS	Nut, $\frac{3}{8}$ " BSF						1	—	C.	
28P/12462	SP.9/C8	Pin, split						1	—	C.	
28FC/11767	K.0054	Washer, shouldered, inboard of ball-race bearing						1	—	C.	
26FC/1765	K.00201	Washer, shouldered, outboard of ball-race bearing						1	—	C.	EF.1
28W/12255	SP.13/J	Washer						1	MR	C.	
26FC/1767	K.00187	PIN , pivot, outboard end of torque tube						2	MR	C.	EF.1
		Attaching parts for K.00187, Pin :—									
28L/13028	A.27/JT	Locknut, $\frac{3}{8}$ " BSF... ..						1	MR	C.	
28W/12255	SP.13/J	Washer						1	MR	C.	
28P/12351	SP.9/E8	PIN , split, securing end of spring						4	—	C.	
26FC/1776	K.00200	PLATE , link, pedal						4	—	C.	EF.1
		Attaching parts for K.00200, Plate :—									
26FC/1787	K.00210	Bolt						1	—	C.	EF.1
28M/13122	A27/GS	Nut, $\frac{3}{8}$ " BSF						1	—	C.	
	K.00188	Piece, distance, $\frac{3}{8}$ " o/d \times 22 SWG \times 0.13" long, T.35 (Make from Ref. No. 30A/1929)						1	—		
28P/12462	SP.9/C8	Pin, split						1	—	C.	
28W/12254	SP.13/G	Washer						1	—	C.	
26FC/1770	K.00197	PLATE , ratchet, pedal adjustment, L.H.						2	MR	C.	EF.1
26FC/1769	K.00196	PLATE , ratchet, pedal adjustment, R.H.						2	MR	C.	EF.1
26FC/1768	K.00194	PLATE , reinforcing, pedal link plate						1	—	C.	EF.1
26BY/3534	K.98297	SPRING , tension, for pedal adjustment						4	—	C.	EF.1
		Attaching parts for K.00908A/ND, Pedals :—									
28D/12569	A25/10E	Bolt, $\frac{1}{2}$ " BSF, centre support bracket						4	—	C.	
28D/12634	A25/18E	Bolt, $\frac{1}{2}$ " BSF, end bearing brackets						4	—	C.	
28M/12928	A27/EP	Nut, $\frac{1}{2}$ " BSF, end bearing brackets						4	—	C.	
28M/12930	A27/ES	Nut, $\frac{1}{2}$ " BSF, centre support bracket						4	—	C.	
28P/12462	SP.9/C8	Pin, split, centre support bracket						4	—	C.	
28W/12298	SP.18/E	Washer, end bearing brackets						4	—	C.	
26BY/2856	DHS.33 Mk. 2	Washer, $\frac{1}{4}$ " BSF, shrinkage, end bearing brackets						8	—	C.	
28W/12253	SP.13/E	Washer, centre support bracket						8	—	C.	

CONTROLS

FLYING CONTROLS IN WING

Ref. No.	Part No.	Nomenclature						No. Off	M.R.	Cl. of St.	Plate No.
		1	2	3	4	5	6				
	—	FLYING CONTROLS IN WING, PORT (12 CF 1)						1	—		EG.3
	—	FLYING CONTROLS IN WING, STARBOARD (12 CF 1)						1	—		EG.3
3569	12 CF 243	BLOCK , clamp, bottom half, for Teleflex conduits on false spar, in Port wing						1	M.R.	C.	EG.3
3568	12 CF 241	BLOCK , clamp, top half, for Teleflex conduits on false spar, in Port wing						1	M.R.	C.	EG.3
		Attaching parts for 12 CF 243 and 12 CF 241, Blocks (per pair) :—									
28M/10288	AGS.2001/C/1	Nut, 2 BA						1	M.R.	C.	
28W/12245	SP.10/C	Washer						1	M.R.	C.	
3567	12 CF 215	BLOCK , clamp, half, for Teleflex conduits on rib No. 1, in Port wing						4	M.R.	C.	EG.3
		Attaching parts for 12 CF 215, Block (per pair) :—									
26FN/2113	DHS.157/6	Bolt, 2 BA, captive						1	M.R.	C.	
28M/10288	AGS.2001/C/1	Nut, 2 BA						1	M.R.	C.	
28W/12252	SP.13/C	Washer						1	M.R.	C.	
28D/8316	AS.1242/13C	BOLT , 2 BA, for cable guard tube on rear pulley bracket, rib No. 1, Starboard						1	M.R.	C.	
28D/12514	A25/7C	BOLT , 2 BA, for cable guard tube on rear pulley bracket rib No. 1, Starboard						1	M.R.	C.	
28D/12538	A25/15C	BOLT , 2 BA, for cable guard tube						1	M.R.	C.	
28D/12539	A25/16C	BOLT , 2 BA, for cable guard tube						1	M.R.	C.	
28D/12540	A25/18C	BOLT , 2 BA, for cable guard tube						1	M.R.	C.	
28D/12512	A25/1C	BOLT , 2 BA, for elevator trim cable bracket ...						2	—	C.	
28D/12534	A25/9C	BOLT , 2 BA, for elevator trim cable fairlead ...						2	—	C.	
2736	12 CF 21A/ND	BRACKET , complete with aileron balance pulley, top, rear end, on rib No. 1, Port						1	M.R.	C.	EG.3
7701	12 CF 22A/ND	BRACKET , complete with aileron balance pulley, top, rear end, on rib No. 1, Starboard						1	M.R.	C.	EG.3
28D/12658	A28/11J	BOLT , 3/8" BSF						1	M.R.	C.	
	12 CF 19	BRACKET , Port						1	M.R.		EG.3
	12 CF 20	BRACKET , Starboard						1	M.R.		EG.3
28M/6039	A18/JS	NUT , 3/8" BSF						1	M.R.	C.	
28P/12462	SP.9/C8	PIN , split						5	M.R.	C.	
406	12 CF 97A	PULLEY , cable						1	M.R.	C.	EG.1 EG.3 EG.3
	K.00323	TUBE , cable guard, 1/4" o/d x 20 SWG x 1.48" long, T.26 (Make from Ref. No. 30A/964)						2	M.R.		
		Attaching parts for 12 CF 21A/ND and 12 CF 22A/ND, Brackets :—									
28D/8342	AS.1248/2C	Bolt, 2 BA						4	M.R.	C.	
28M/12929	A27/CP	Nut, 2 BA						4	M.R.	C.	
2740	12 CF 443A/ND	BRACKET , complete with pulleys, bottom, rear end, on rib No. 1, Port						1	M.R.	C.	EG.3
7700	12 CF 18A/ND	BRACKET , complete with pulleys, bottom, rear end, on rib No. 1, Starboard						1	M.R.	C.	EG.3
	12 CF 9	BRACKET , Port						1	M.R.		EG.3
	12 CF 10	BRACKET , Starboard						1	M.R.		EG.3
28M/6039	A18/JS	NUT , 3/8" BSF						2	M.R.	C.	
28P/12462	SP.9/C8	PIN , split						6	M.R.	C.	
406	12 CF 97A	PULLEY , Port						3	M.R.	C.	EG.3
406	12 CF 97A	PULLEY , Starboard						5	M.R.	C.	EG.3

FLYING CONTROLS IN WING

Ref. No.	Part No.	Nomenclature						No. Off	M.R.	Cl. of St.	Plate No.
		1	2	3	4	5	6				
405	12 CF 7 K.00291							2	—	C.	EG.3
	AS.2811/8/022							4	M.R.		EG.3
	AS.2811/8/122							—			
								1	M.R.		
								2			
								1	M.R.		
								1	M.R.		
								4	M.R.	C.	
28D/10640	AS.1248/2E							4	M.R.	C.	
28M/12928	A27/EP							4	M.R.	C.	
7709	12 CF 429A/ND							1	M.R.	B.	EG.2
	12 CF 11							1	M.R.		EG.2
28R/13514	AS.103							2	—	B.	EG.2
28D/12516	A25/11C							2	—	C.	
28M/10288	AGS.2001/C/1							2	—	C.	
28M/12930	A27/ES							1	—	C.	
28P/12462	SP.9/C8							1	—	C.	
26FC/2583	K.00117 Mk. 1							1	—	C.	EG.2
26FC/2584	K.00117 Mk. 2							1	—	C.	EG.2
26FC/2579	K.00115							1	—	C.	EG.2
	AS.2809/4/100							2	—		
28W/12352	SP.10/E							1	—	C.	
2737	12 CF 193A							1	M.R.	B.	
26BY/4552	SKEFKO							2	M.R.	B.	
	400602/C-001							1	M.R.	C.	
28D/8329	AS.1242/9E							1	M.R.	C.	
28D/12124	AS.1242/19E							1	M.R.	C.	
28D/10784	AS.1242/17E							1	M.R.	C.	
28D/12130	AS.1242/17G							1	M.R.	C.	
28D/12474	AS.1242/19G							1	M.R.	C.	
28D/9300	AS.1242/18G							1	—	C.	
424	12 CF 175A							1	—	C.	
425	12 CF 177A							1	—	C.	EG.2
420	12 CF 165A							1	—	C.	
859	12 CF 353A							1	—	C.	EG.2
28L/13326	A.27/GT							1	—	C.	
28L/12931	A.27/ET							1	—	C.	
10146	12 CF 1175							1	—	C.	
26FC/5384	K.00934							1	—	C.	
26FC/5383	K.00933							1	—	C.	
26FC/3712	K.00465							1	—	C.	EG.2
26FC/3714	K.00467							1	—	C.	EG.2
26FC/2588	K.00149							1	—	C.	EG.2
26FC/2580	K.00152							1	M.R.	C.	EC.2
28W/12354	SP.10/G							1	M.R.	C.	

FLYING CONTROLS IN WING

Ref. No.	Part No.	Nomenclature						No. Off	M.R.	Cl. of St.	Plate No.
		1	2	3	4	5	6				
26FC/2581	K.0099							1	—	C.	EG.2
26FC/2582	K.00100							1	—	C.	EG.2
28D/12543	A25/6E							3	M.R.	C.	
28D/12639	A25/6G							3	M.R.	C.	
28M/12930	A27/ES							3	M.R.	C.	
28M/13122	A29/GS							3	M.R.	C.	
28P/12462	SP.9/C8							6	M.R.	C.	
	AS.2811/7/226							1	M.R.		
28W/12253	SP.13/E							3	M.R.	C.	
28W/12254	SP.13/G							3	M.R.	C.	
7708	12 CF 427A/ND							1	M.R.	B.	EG.2
	12 CF 12							1	—		EG.2
1190	12 CF 407A							1	—	C.	EG.2
7707	12 CF 389A							1	M.R.	B.	EG.2
26BY/4552	SKEFKO 400602/C-001							2	M.R.	B.	
28D/10784	AS.1242/17E							1	M.R.	C.	
28D/11245	AS.1242/18E							1	M.R.	C.	
28D/9300	AS.1242/18G							2	M.R.	C.	
422	12 CF 169A							1	—	C.	EG.2
857	12 CF 349A							1	—	C.	EG.2
421	12 CF 167A							1	—	C.	EG.2
1791	12 CF 735A							1	—	C.	EG.2
28L/12931	A.27/ET							1	—	C.	
28L/13326	A.27/GT							2	—	C.	
28M/12928	A27/EP							1	—	C.	
1192	12 CF 385							1	—	C.	EG.2
1191	12 CF 387							1	—	C.	EG.2
26FC/2588	K.00149							1	—	C.	
28W/12254	SP.13/G							2	—	C.	
5808	12 CF 195A/1							1	M.R.	B.	EG.2
26BY/4552	SKEFKO 400602/C-001							2	M.R.	B.	
28D/8329	AS.1242/9E							1	M.R.	C.	
28D/12124	AS.1242/19E							1	M.R.	C.	
28D/10784	AS.1242/17E							1	M.R.	C.	
28D/12130	AS.1242/17G							1	M.R.	C.	
28D/12474	AS.1242/19G							1	M.R.	C.	
28D/9300	AS.1242/18G							1	—	C.	
860	12 CF 357A							1	—	C.	EG.2
425	12 CF 177A							1	—	C.	EG.2
420	12 CF 165A							1	—	C.	EG.2
859	12 CF 353A							1	—	C.	EG.2
28L/12931	A.27/ET							1	—	C.	

FLYING CONTROLS IN WING

Ref. No.	Part No.	Nomenclature						No. Off	M.R.	Cl. of St.	Plate No.
		1	2	3	4	5	6				
28L/13326 10146	A.27/GT 12 CF 1175	LOCKNUT , $\frac{5}{16}$ " BSF (Pre Mod. Ven. 888) ...						1	—	C.	
		NUT , special, $\frac{5}{16}$ " BSF, cable attachment ... (Mod. Ven. 888)						1	—	C.	
26FC/5384	K.00934	NUT , $\frac{1}{4}$ " BSF ...						1	—	C.	EG.2
26FC/5383 1476	K.00933 12 CF 481	NUT , $\frac{5}{16}$ " BSF ...						1	—	C.	EG.2
1475	12 CF 479	PULLEY , double, elliptical ...						1	—	C.	EG.2
26FC/2588	K.00149	PULLEY , double, round ...						1	—	C.	EG.2
		TUBE , distance, between ball-race bearings						1	—	C.	
		Attaching parts for 12 CF 389A and 12 CF 195A/1, Pulleys (per pair) :—									
1189	12 CF 419	Bolt, special ...						1	M.R.	C.	EG.2
28M/13122	A27/GS	Nut, $\frac{5}{16}$ " BSF ...						1	M.R.	C.	
28P/12462	SP.9/C8	Pin, split ...						1	M.R.	C.	
28W/12254	SP.13/G	Washer ...						1	M.R.	C.	
28W/12700	SP.10/J	Washer ...						1	M.R.	C.	
26FC/2581	K.0099	SPIGOT , female, cable guard ...						1	—	C.	
26FC/2582	K.00100	SPIGOT , male, cable guard ...						1	—	C.	
		Attaching parts for 12 CF 427A/ND, Bracket :—									
28D/12543	A25/6E	Bolt, $\frac{1}{4}$ " BSF, outboard ...						3	M.R.	C.	
28D/12639	A25/6G	Bolt, $\frac{5}{16}$ " BSF, inboard ...						3	M.R.	C.	
28M/12930	A27/ES	Nut, $\frac{1}{4}$ " BSF ...						3	M.R.	C.	
28M/13122	A27/GS	Nut, $\frac{5}{16}$ " BSF ...						3	M.R.	C.	
28P/12462	SP.9/C8	Pin, split ...						6	M.R.	C.	
28W/12253	SP.13/E	Washer ...						3	M.R.	C.	
28W/12254	SP.13/G	Washer ...						3	M.R.	C.	
3570	12 CF 155A	BRACKET , mounting, for aileron jockey pulley on false spar						1	M.R.	C.	EG.1
		Attaching parts for 12 CF 155A, Bracket :—									
28D/12531	A25/3C	Bolt, 2 BA ...						4	M.R.	C.	
28M/12929	A27/CP	Nut, 2 BA ...						4	M.R.	C.	
	12 CF 163	Packing, 3-0" long x 0-70" wide x $\frac{1}{16}$ " thick, LFS.21						2	M.R.	C.	EG.1
28W/12296	SP.15/C	Washer ...						4	M.R.	C.	
1295	12 CF 473	BRACKET , on false spar, elevator trim control cable						1	—	C.	EG.3
411	12 CF 141ND	BRACKET , pulley mounting, bottom front, on rib No. 1, Port						1	M.R.	C.	EG.1
412	12 CF 142ND	BRACKET , pulley mounting, bottom front, on rib No. 1, Starboard						1	M.R.	C.	EG.1
409	12 CF 139ND	BRACKET , pulley mounting, top front, on rib No. 1, Port						1	M.R.	C.	EG.1
410	12 CF 140ND	BRACKET , pulley mounting, top front, on rib No. 1, Starboard						1	M.R.	C.	EG.1
		Attaching parts for 12 CF 141ND, 12 CF 142ND, 12 CF 139ND and 12 CF 140ND, Brackets :—									
28D/12512	A25/1C	Bolt, 2 BA ...						5	—	C.	
28M/10288	AGS.2001/C/1	Nut, 2 BA ...						2	—	C.	
28W/12252	SP.13/C	Washer ...						2	—	C.	
2941	12 CF 769	BRACKET , pulley mounting, bottom rear, on rib No. 1, Port						1	M.R.	C.	EG.1
2942	12 CF 770	BRACKET , pulley mounting, bottom rear, on rib No. 1, Starboard						1	M.R.	C.	EG.1
2939	12 CF 767	BRACKET , pulley mounting, top rear, on rib No. 1, Port						1	M.R.	C.	EG.1

FLYING CONTROLS IN WING

Ref. No.	Part No.	Nomenclature						No. Off	M.R.	Cl. of St.	Plate No.
		1	2	3	4	5	6				
2940	12 CF 768	BRACKET , pulley mounting, top rear, on rib No. 1, Starboard						1	MR	C.	EG.1
28D/8306	AS.1242/1C	Attaching parts for 12 CF 769, 12 CF 770, 12 CF 767 and 12 CF 768, Brackets :—						4	MR	C.	
2739	12 CF 198A	CABLE , elevator trim, lower, in Port wing ...						1	MR	C.	EG.3
2738	12 CF 197A	CABLE , elevator trim, upper, in Port wing ...						1	MR	C.	EG.3
27K/568	B.29140	CLAMP , conduit connector, on rib No. 1, Teleflex, in Port wing						2	—	C.	EG.3
7713	12 CF 989ND	CONDUIT , Teleflex No. 2 on rib No. 1, Port wing						1	—	—	EG.3
7714	12 CF 991ND	CONDUIT , Teleflex No. 2 on rib No. 1, Port wing						1	—	—	EG.3
27K/	B.10699	CONNECTOR , between elevator trim cable and Teleflex cable on false spar, Teleflex in Port wing (See AP.4515G, Vol. 3, Pt. 1 for Breakdown)						1	—	C.	EG.3
27K/	B.10700	CONNECTOR , between elevator trim cable and Teleflex cable on false spar, Teleflex, in Port wing (See AP.4515G, Vol. 3, Pt. 1 for Breakdown)						1	—	C.	EG.3
3571	12 CF 265	FAIRLEAD , at aileron jockey pulley on false spar						1	MR	C.	EG.7
1296	12 CF 475	FAIRLEAD , elevator trim ...						1	—	C.	EG.3
1297	12 CF 477	FAIRLEAD , elevator trim ...						2	—	C.	EG.3
417	12 CF 281ND	GUARD , cable, at rear of front pulley brackets, on rib No. 1, Starboard						1	—	C.	EG.1
28L/765	A16Y/BTL	LOCKNUT , 4 BA, for turnbuckle on elevator trim cable, upper, at false spar in port wing (Mod. Ven. 518)						1	—	C.	
28L/754	A16Y/BT	LOCKNUT , 4 BA, for turnbuckle on elevator trim cable, lower, at false spar in port wing (Mod. Ven. 518)						1	—	C.	
28M/10288	AGS.2001/C/1	NUT , 2 BA, plain, for cable guard bolt, elevator trim cable bracket and fairlead						5	MR	C.	
28M/10328	AGS.2002/C/1	NUT , 2 BA, for cable guard bolt ...						4	MR	C.	
576	12 CF 117A	PULLEY , cable, aileron, front of top and bottom front brackets						1	MR	C.	EG.1
		Attaching parts for 12 CF 117A, Pulley :—									
28D/12659	A28/12J	Bolt, 3/8" BSF ...						1	MR	C.	
28M/6039	A18/JS	Nut, 3/8" BSF ...						1	MR	C.	
28P/12462	SP.9/C8	Pin, split ...						1	MR	C.	
	DHS.329/062	Tube, distance ...						1	MR		
408	12 CF 133A	PULLEY , cable, aileron, intermediate, on top and bottom front brackets						1	MR	C.	EG.1
		Attaching parts for 12 CF 133A, Pulley :—									
28D/12663	AS.1242/14J	Bolt, 3/8" BSF ...						1	MR	C.	
28M/13123	A27/JS	Nut, 3/8" BSF ...						1	MR	C.	
28P/12462	SP.9/C8	Pin, split ...						1	MR	C.	
	DHS.329/072	Tube, distance ...						1	MR		
398	12 CF 153A	PULLEY , cable, aileron jockey, on false spar ...						1	MR	C.	EG.1
		Attaching parts for 12 CF 153A, Pulley :—									
399	12 CF 161	Bolt ...						1	—	C.	EG.1
28W/12256	SP.13/J	Washer ...						1	—	C.	

CONTROLS

FLYING CONTROLS IN WING

Ref. No.	Part No.	Nomenclature						No. Off	M.R.	Cl. of St.	Plate No.
		1	2	3	4	5	6				
868	12 CF 365A	PULLEY , cable, aileron, rear brackets, Port ...						1	MR	C.	EG.1
28D/12661	A28/17J	Attaching parts for 12 CF 365A, Pulley :—									
28M/6039	A18/JS	Bolt, " BSF ...						1	MR	C.	
	DHS.329/065	Nut, " BSF ...						1	MR	C.	
	DHS.329/050	Tube, distance ...						1	MR		
		Tube, distance ...						1	MR		
868	12 CF 365A	PULLEY , cable, aileron, rear brackets, Starboard						1	MR	C.	EG.1
408	12 CF 133A	PULLEY , cable, elevator, rear brackets, Starboard						1	MR	C.	EG.1
		Attaching parts for 12 CF 365A and 12 CF 133A, Pulleys (per pair)									
28D/12661	A28/17J	Bolt, " BSF ...						1	MR	C.	
28M/6039	A.18/JS	Nut, " BSF ...						1	MR	C.	
28P/12462	SP.9/C8	Pin, split ...						1	MR	C.	
	DHS.329/065	Tube, distance ...						1	MR		
402	12 CF 85A	PULLEY , cable, elevator, rear of top and bottom front brackets, Starboard						1	MR	C.	EG.1
576	12 CF 117A	PULLEY , cable, elevator, rear of top and bottom front brackets, Starboard						1	MR	C.	EG.1
		Attaching parts for 12 CF 85A and 12 CF 117A, Pulleys (per pair) :—									
28D/12660	A28/15J	Bolt, " BSF ...						1	MR	C.	
28M/6039	A18/JS	Nut, " BSF ...						1	MR	C.	
28P/12462	SP.9/C8	Pin, split ...						1	MR	C.	
	DHS.329/011	Tube, distance, between pulleys ...						1	MR		
	DHS.329/018	Tube, distance, lower ...						1	MR		
	DHS.329/010	Tube, distance, upper ...						1	MR		
868	12 CF 365A	PULLEY , cable, rudder and elevator, rear brackets, Starboard						2	MR	C.	
		Attaching parts for 12 CF 365A, Pulley :—									
28D/12659	A28/12J	Bolt, " BSF ...						1	MR	C.	
28M/6039	A18/JS	Nut, " BSF ...						1	MR	C.	
28P/12462	SP.9/C8	Pin, split ...						1	MR	C.	
	DHS.329/015	Tube, distance ...						1	MR		
406	12 CF 97A	PULLEY , cable, rudder, centre top and bottom front brackets, Port						1	MR	C.	EG.1
		Attaching parts for 12 CF 97A, Pulley —									
28D/12662	A28/19J	Bolt, " BSF ...						1	MR	C.	
28M/6039	A18/JS	Nut, " BSF ...						1	MR	C.	
28P/12462	SP.9/C8	Pin, split ...						1	MR	C.	
	DHS.329/1-25	Tube, distance ...						1	MR		
406	12 CF 97A	PULLEY , cable, rudder, centre top and bottom front brackets, Starboard						1	MR	C.	
408	12 CF 133A	PULLEY , cable, rudder, centre top and bottom front brackets, Starboard						1	MR	C.	
		Attaching parts for 12 CF 97A and 12 CF 133A, Pulleys (per pair) :—									
28D/12662	A28/19J	Bolt, " BSF ...						1	MR	C.	
28M/6039	A18/JS	Nut, " BSF ...						1	MR	C.	
28P/12462	SP.9/C8	Pin, split ...						1	MR	C.	
	DHS.329/015	Tube, distance ...						1	MR		
	DHS.329/060	Tube, distance ...						1	MR		

CONTROLS

FLYING CONTROLS IN WING

Ref. No.	Part No.	Nomenclature						No. Off	M.R.	Cl. of St.	Plate No.
		1	2	3	4	5	6				
868	12 CF 365A	PULLEY , cable, rudder, rear brackets, Port ...						1	M.R.	C.	
		Attaching parts for 12 CF 365A, Pulley :—									
28D/12659	A28/12J	Bolt, $\frac{1}{8}$ " BSF ...						1	M.R.	C.	
28M/6039	A18/JS	Nut, $\frac{1}{8}$ " BSF ...						1	M.R.	C.	
	DHS.329/015	Tube, distance ...						1	M.R.		
28U/4054	SP8Y/4	ROD , tension, for control cables ...						10	—	C.	
	AS.2809/4/030	TUBE , cable guard, $\frac{1}{4}$ " o/d \times 22 SWG \times 0-50" long, T.4 (Make from Ref. No. 30B/555)						1	M.R.		
	AS.2809/4/062	TUBE , cable guard, Starboard, $\frac{1}{4}$ " o/d \times 22 SWG \times 0-62" long, T.4 (Make from Ref. No. 30B/555)						2	M.R.		
	AS.2809/4/071	TUBE , cable guard, Starboard, $\frac{1}{4}$ " o/d \times 22 SWG \times 0-71" long, T.4 (Make from Ref. No. 30B/555)						1	M.R.		
	AS.2809/4/125	TUBE , cable guard, $\frac{1}{4}$ " o/d \times 22 SWG \times 1-25" long, T.4 (Make from Ref. No. 30B/555)						3	M.R.		
	AS.2809/4/140	TUBE , cable guard, $\frac{1}{4}$ " o/d \times 22 SWG \times 1-40" long, T.4 (Make from Ref. No. 30B/555)						1	M.R.		
	AS.2809/4/150	TUBE , cable guard, $\frac{1}{4}$ " o/d \times 22 SWG \times 1-50" long, T.4 (Make from Ref. No. 30B/555)						1	M.R.		
28U/7970	AS.2906	TURNBUCKLE , between elevator trim cable and Teleflex cable on false spar, in Port wing						2	—	C.	
<p>Note :—For continuation of Flying Controls in Wing, see also Aerofoils Wing, and Engine Installation, Accessories on Engine Mounting Frames</p>											

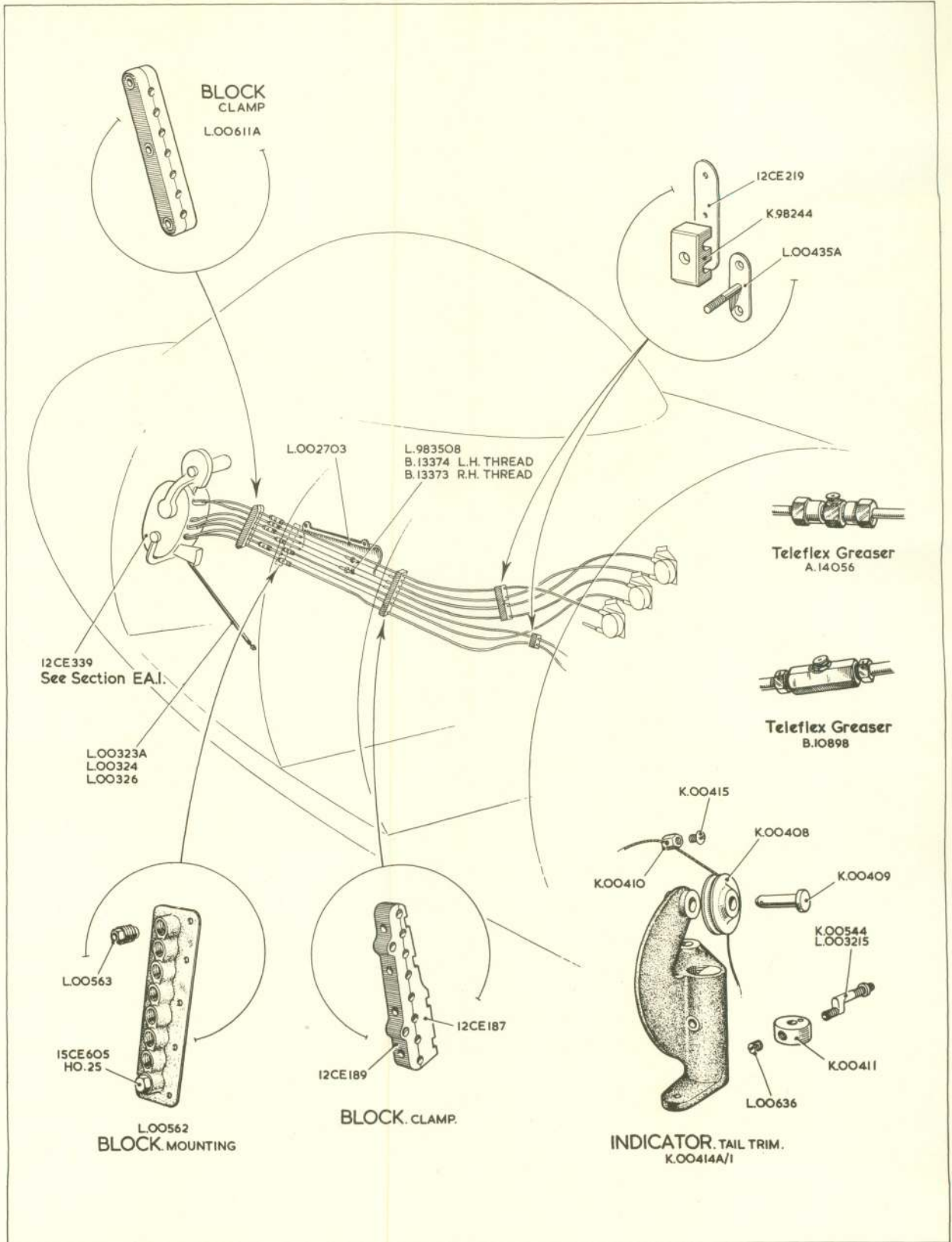

E.1.

**CONTROLS
ENGINE AND TRIM
CONTROLS IN FUSELAGE**

E.1.

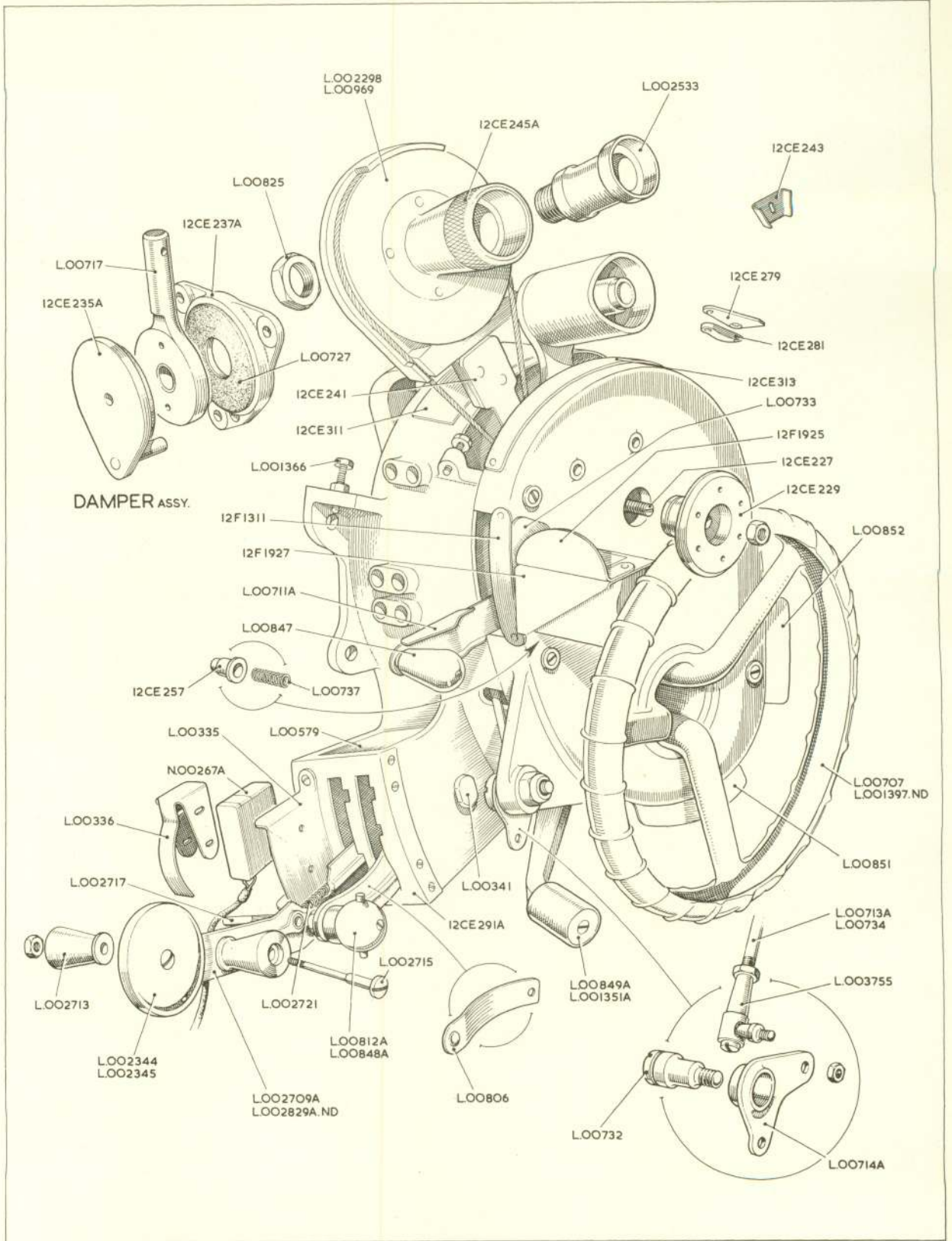

EA.I.

CONTROLS

EA.I.

CONTROL BOX

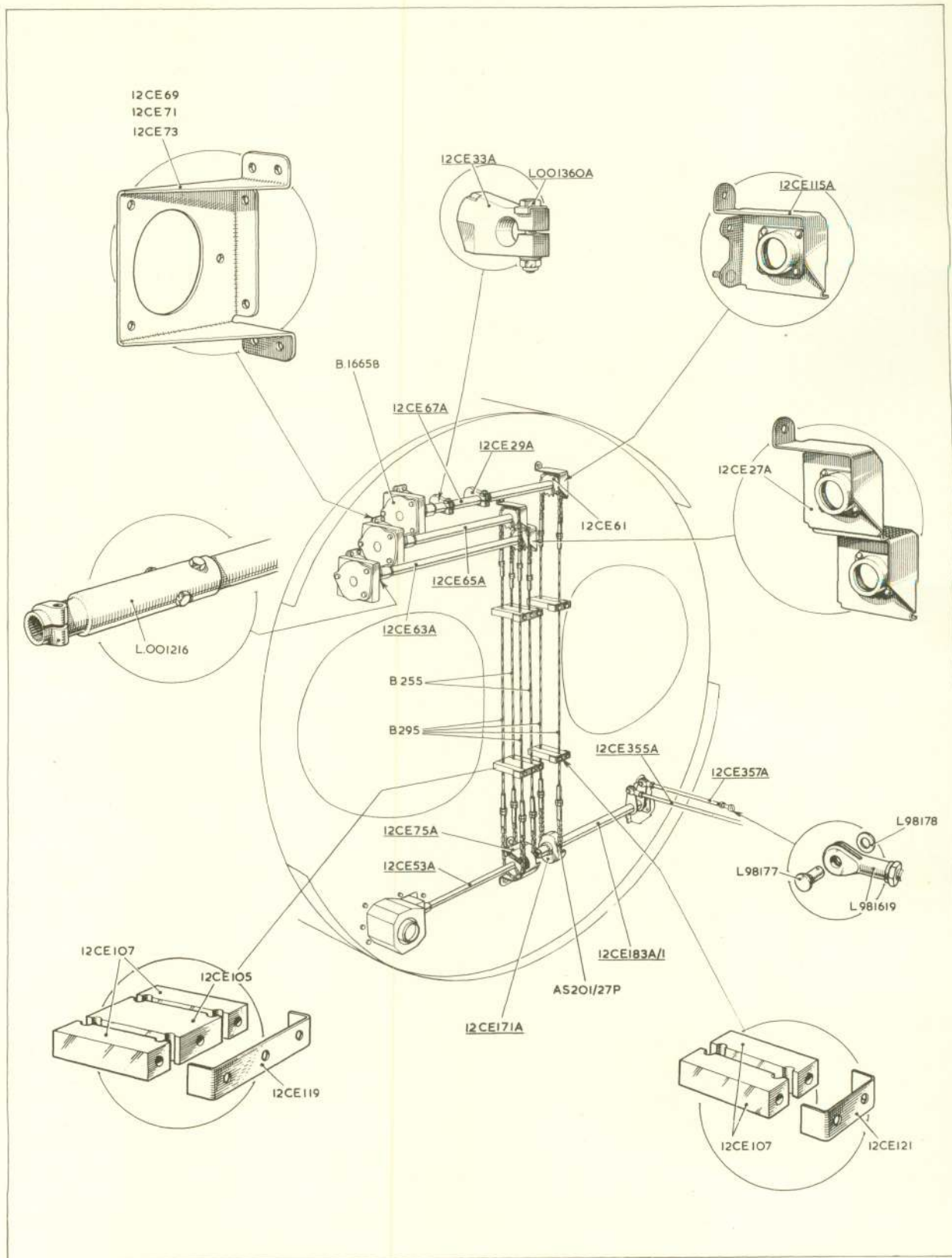

EB.1.

CONTROLS ENGINE CONTROLS ON FIREPROOF BULKHEAD

EB.1.

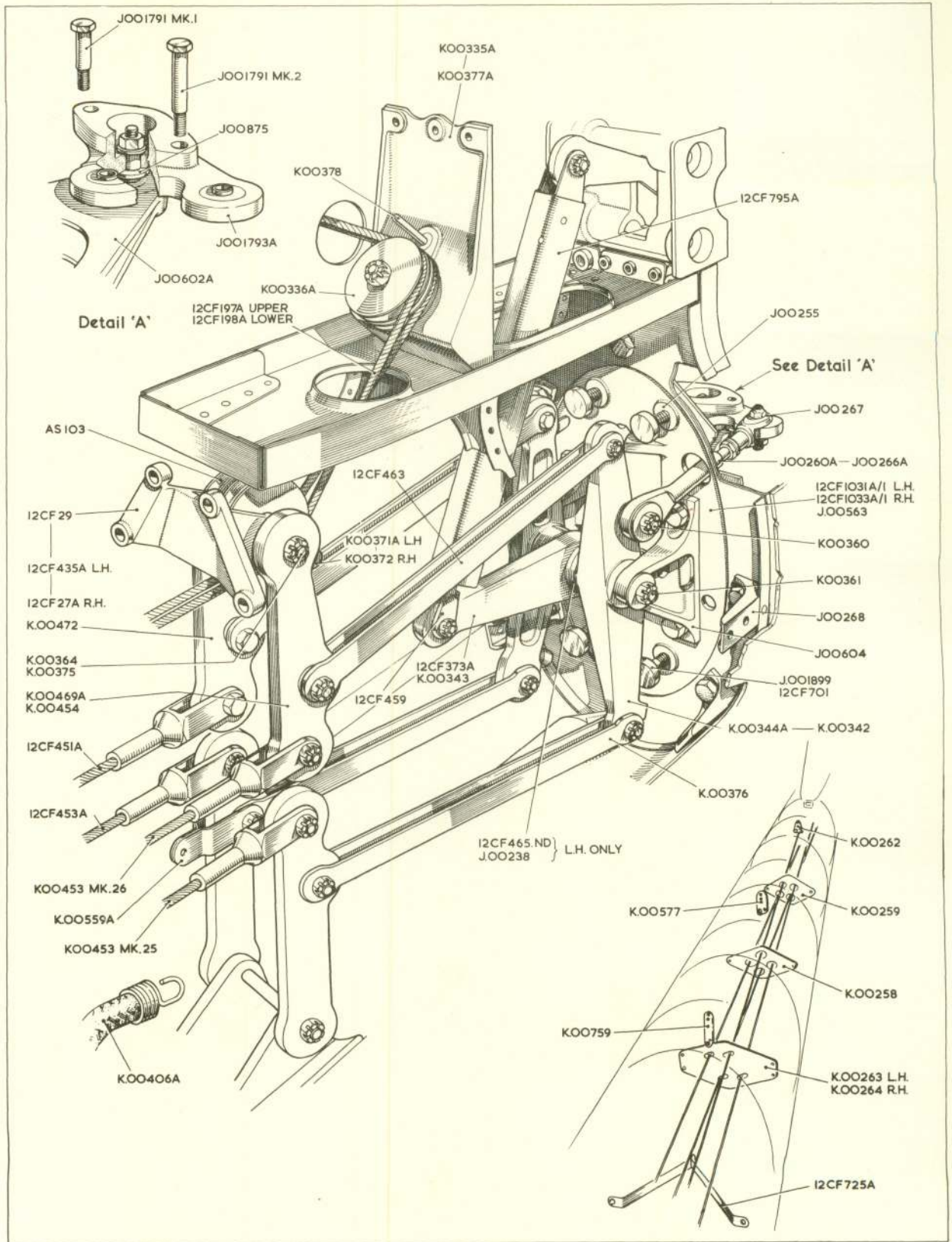

EC.I.

CONTROLS

EC.I.

FLYING CONTROLS IN BOOMS

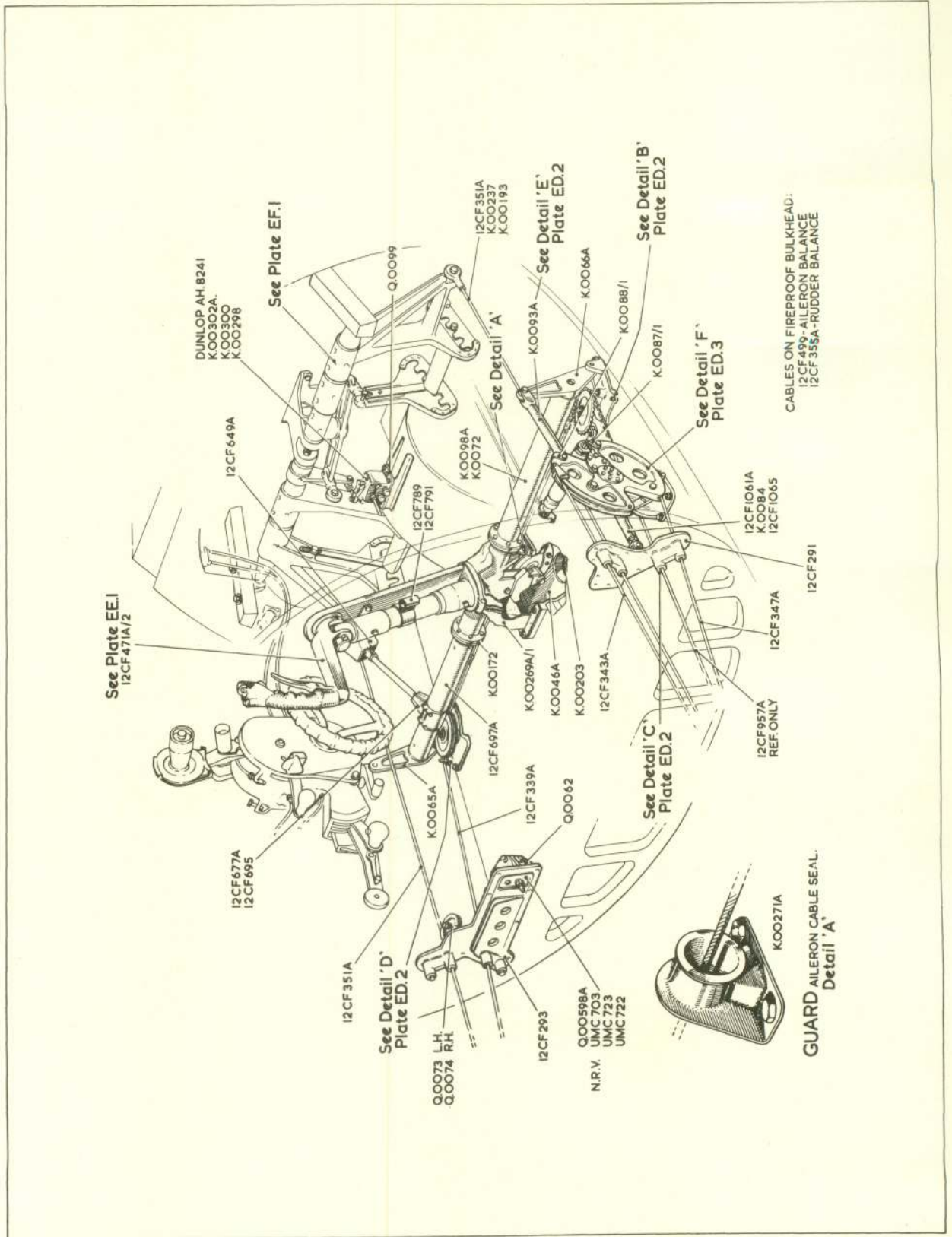

ED.I.

CONTROLS

ED.I.

FLYING CONTROLS IN FUSELAGE

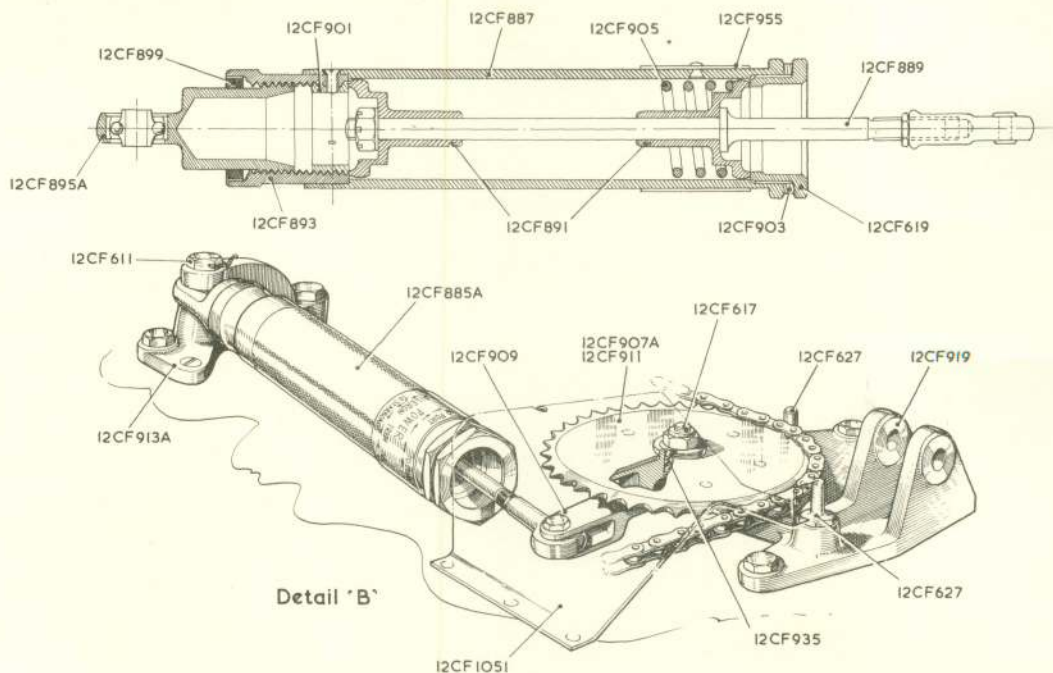

STRUT SPRING, AILERON.

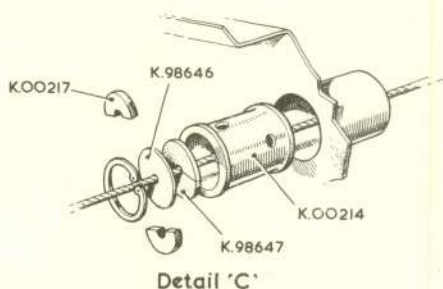

Detail 'C'

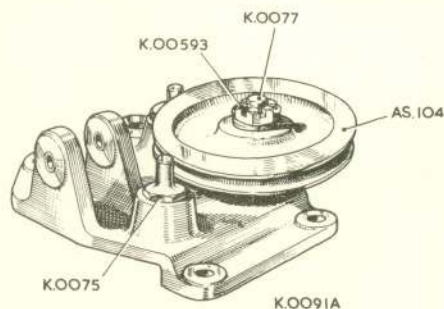

Detail 'D'
BRACKET PORT, AILERON PULLEY & TORQUE LEVER.

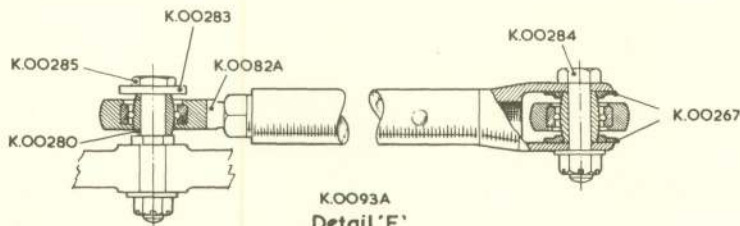

Detail 'E'

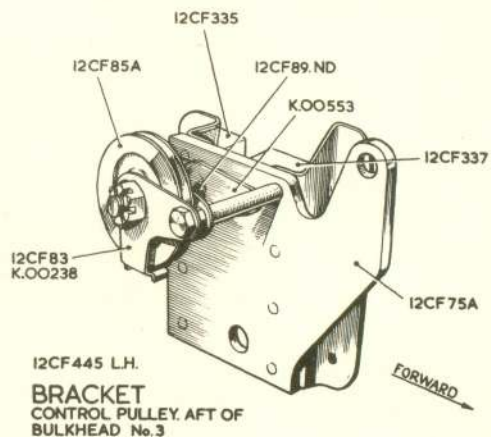
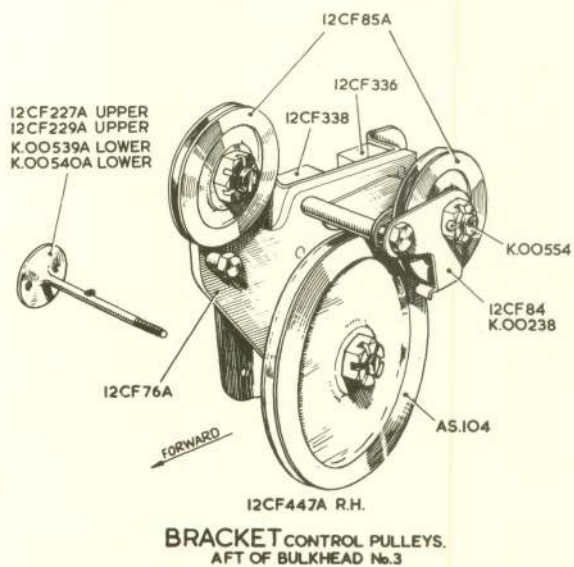
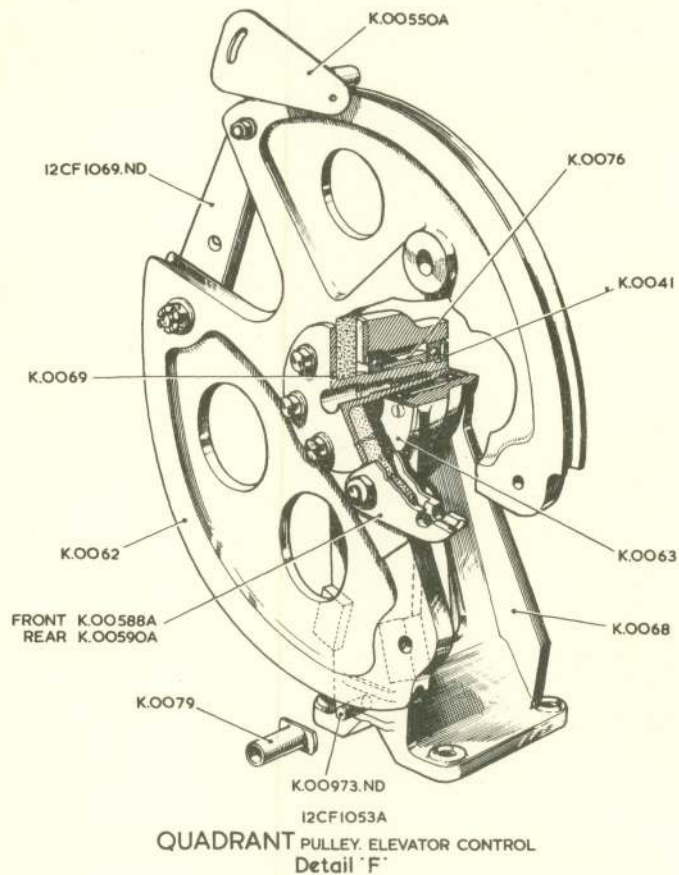

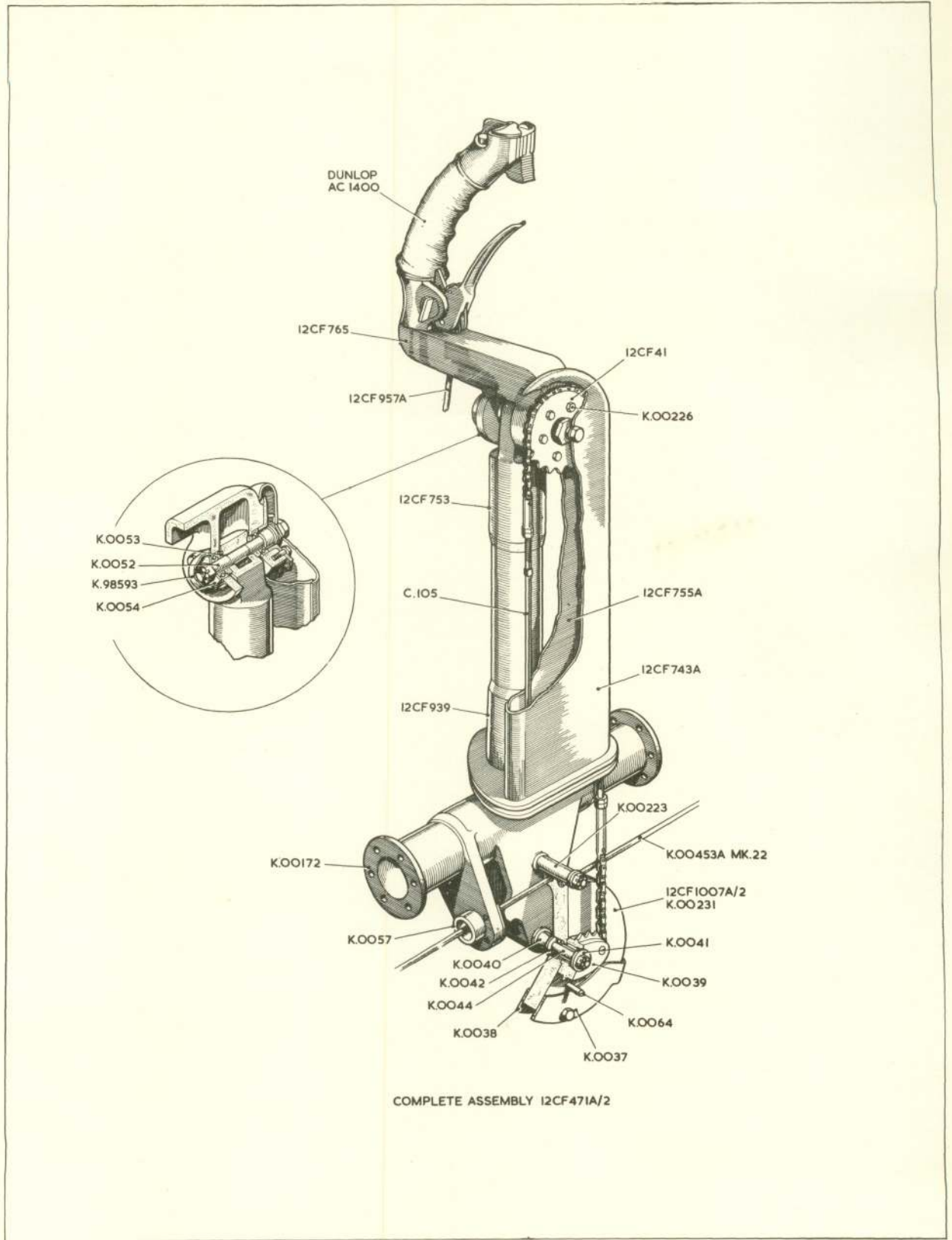

EE.I.

CONTROLS

EE.I.

CONTROL COLUMN

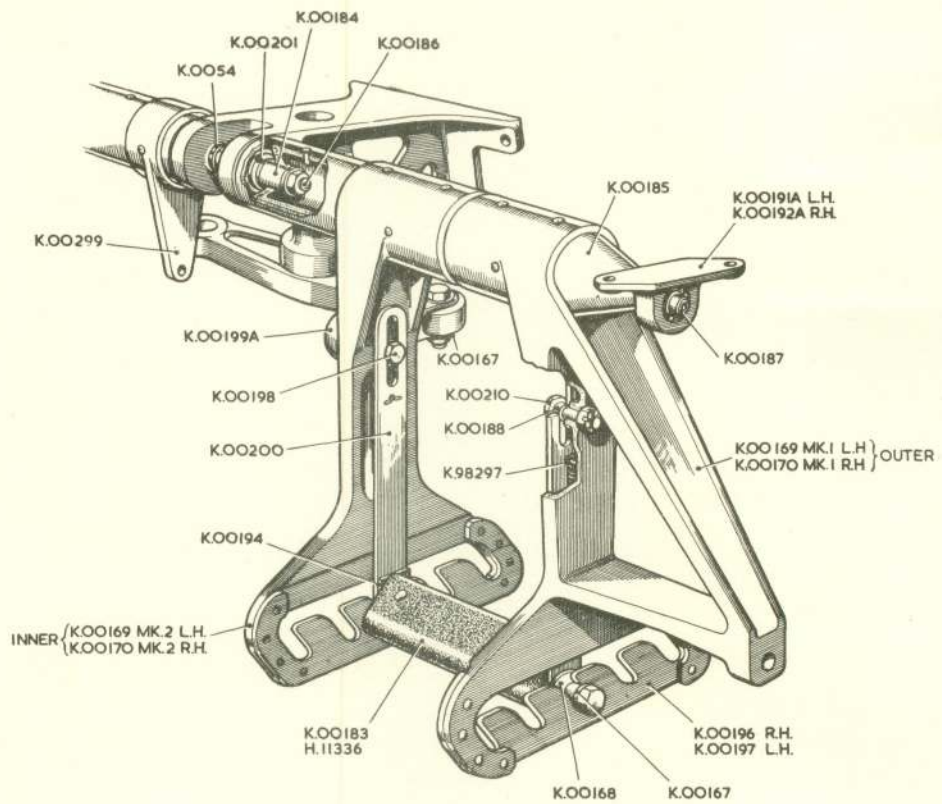

K.OO908A.ND
PEDALS RUDDER

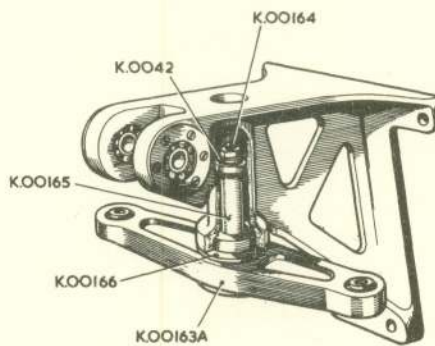

K.OO171A
BRACKET. CENTRE SUPPORT.

EF.1.

CONTROLS

EF.1.

RUDDER PEDAL ARRANGEMENT

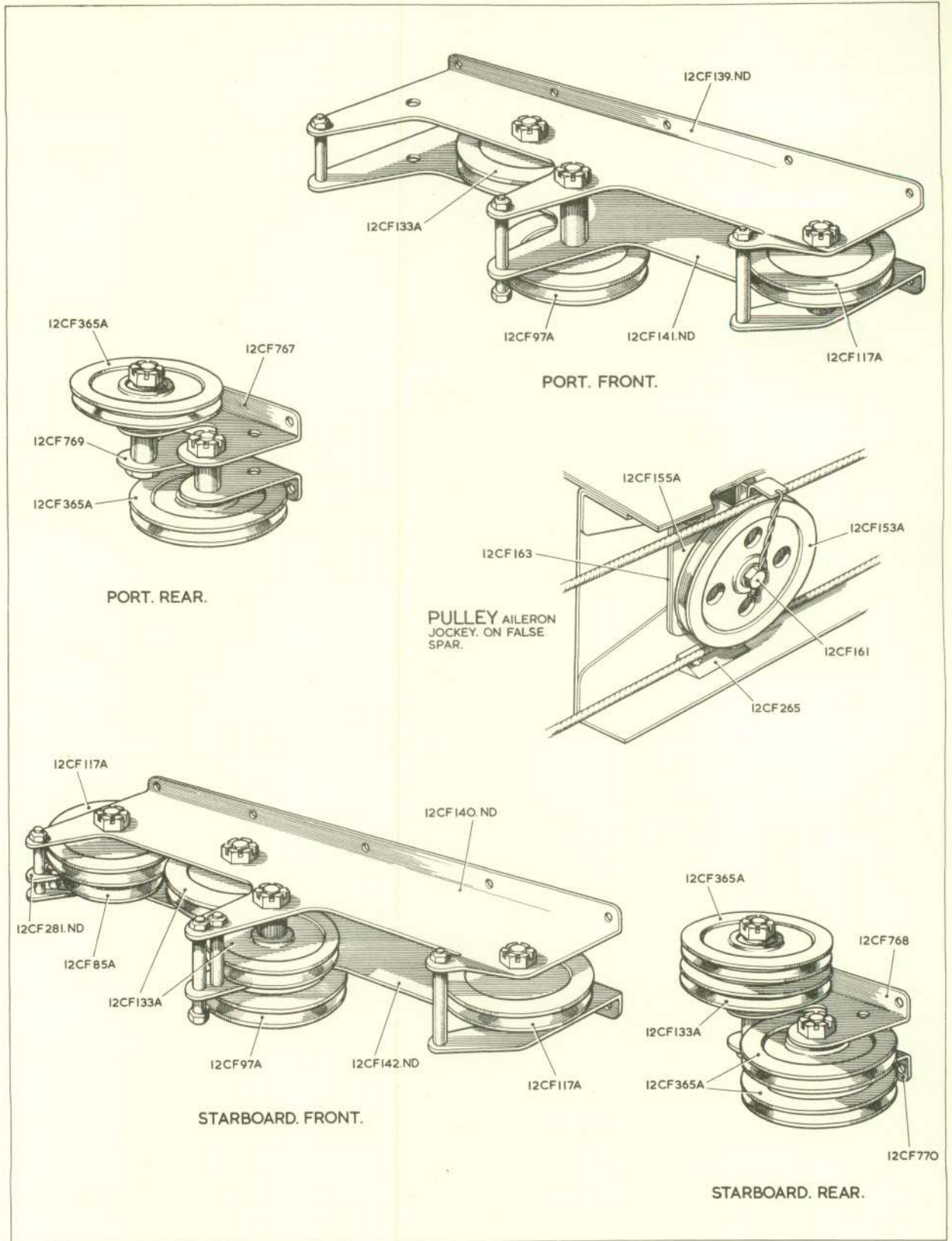

EG.1.

CONTROLS

EG.1.

FLYING CONTROLS IN WING

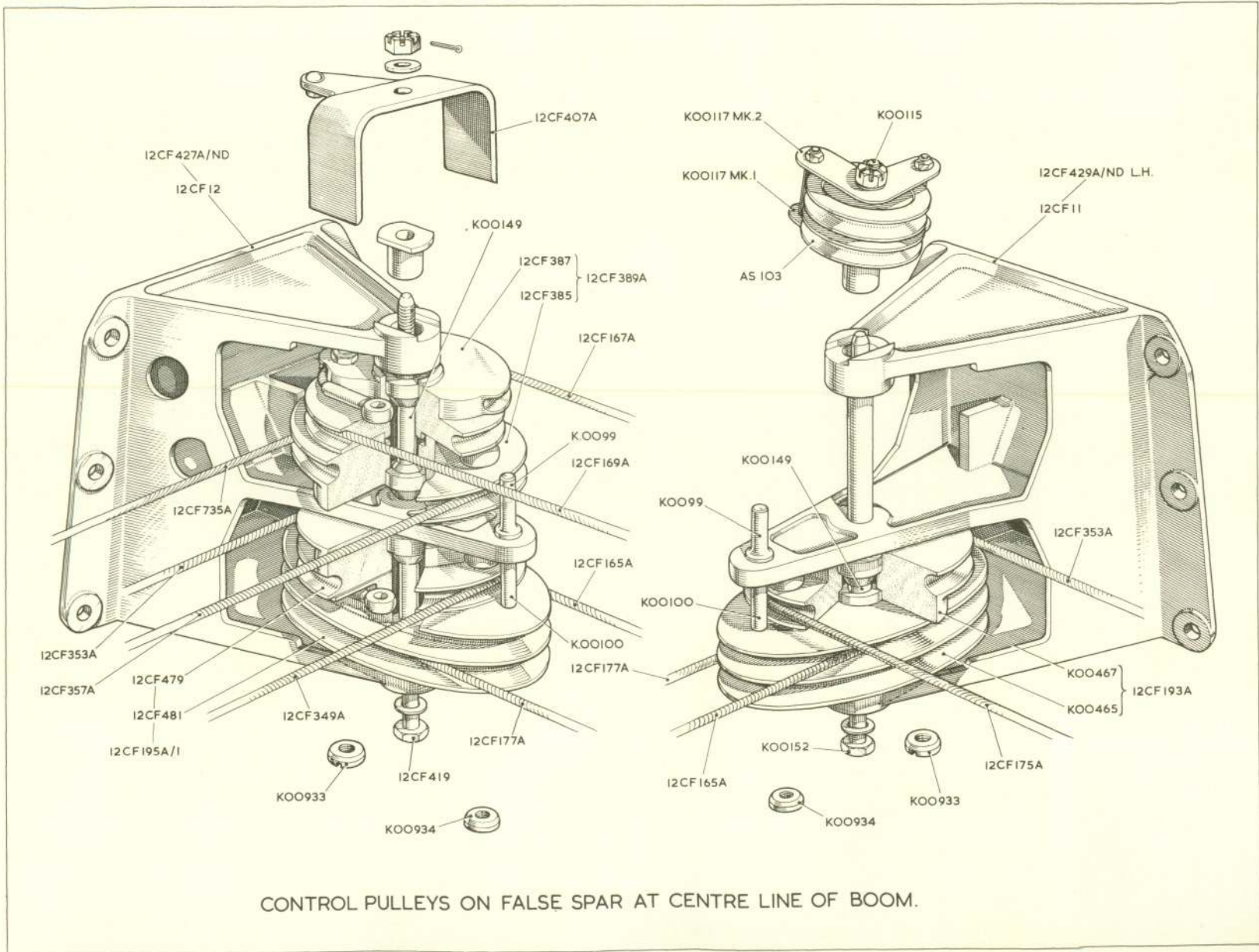

CONTROL PULLEYS ON FALSE SPAR AT CENTRE LINE OF BOOM.

EG.2.

CONTROLS

FLYING CONTROLS IN WING

RESTRICTED

EG.2.

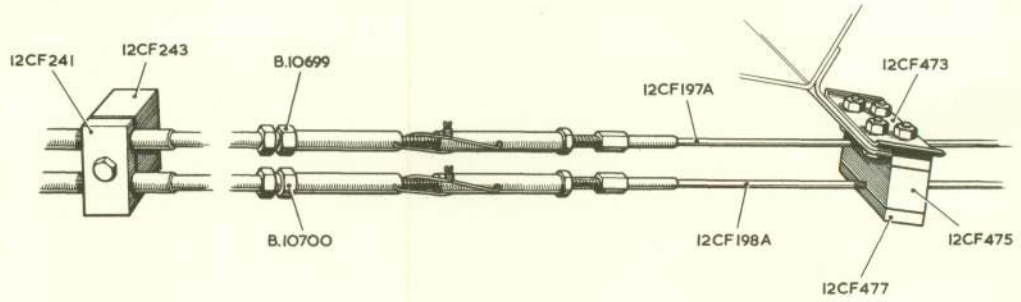

ELEVATOR TRIM CONTROL RUN ON FALSE SPAR.

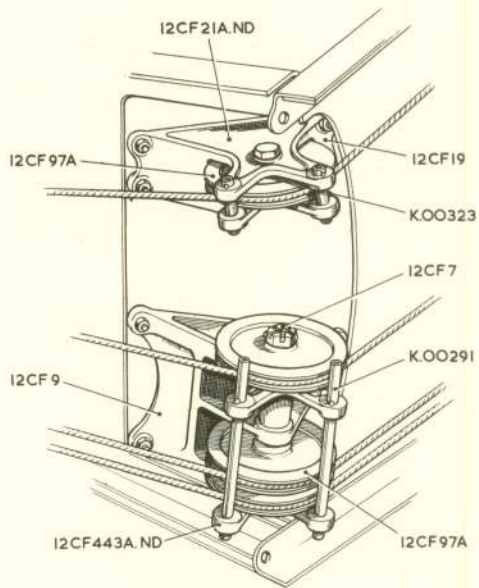
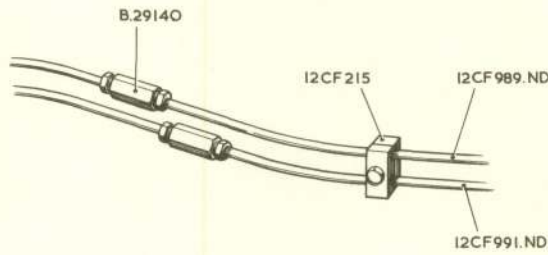

PORT.

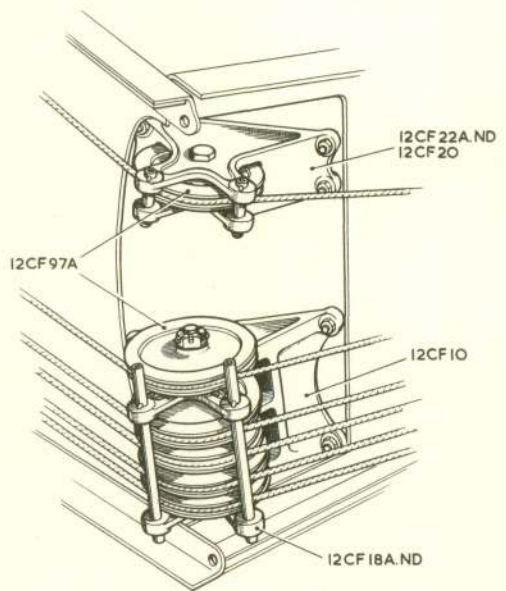

STARBOARD.

EG.3.

CONTROLS

EG.3.

FLYING CONTROLS IN WING

HAND INK ALTERATIONS

Insert in the "Plate No." Column the following plate numbers against the undermentioned Part Numbers :—

PAGE E.1

Ref. No.	Part No.	Plate No.	Ref. No.	Part No.	Plate No.
	B.13374	E.1		793	12 CE 187
	B.13373	E.1	26FC/3636	L.00562	E.1
26BY/10509	L.983508	E.1		12 CE 339	E.1
26FC/2087	L.00611A	E.1	26BY/753	K.98244	E.1
794	12 CE 189	E.1	26FC/2733	K.00410	E.1
			26FC/2934	K.00415	E.1

PAGE E.2

Ref. No.	Part No.	Plate No.	Ref. No.	Part No.	Plate No.
27K/735	A.14056	E.1	26FC/2079	L.00636	E.1
27K/717	B.10898	E.1		L.00435A	E.1
26FC/4701	L.002703	E.1		12 CE 219	E.1
26FC/4328	K.00414A/1	E.1	26FC/5947	15 CE 605	E.1
26FC/2930	K.00544	E.1	26FC/2085	HO. 25	E.1
	K.00409	E.1	26FC/2082	L.00323A	E.1
26FC/4326	L.003215	E.1	26FC/2083	L.00324	E.1
26FC/2931	K.00411	E.1	26FC/2084	L.00326	E.1
26FC/2932	K.00408	E.1	26FC/2086	L.00563	E.1

PAGE EA.1

Ref. No.	Part No.	Plate No.	Ref. No.	Part No.	Plate No.
26FC/2122	L.00714A	EA.1	26FC/2124	L.00335	EA.1
26FC/2094	L.00732	EA.1		12 F 1927	EA.1
26FC/3961	L.001366	EA.1		12 CE 257	EA.1

PAGE EA.2

Ref. No.	Part No.	Plate No.	Ref. No.	Part No.	Plate No.
	12 CE 243	EA.1	26FC/2727	L.001351A	EA.1
	12 CE 235A	EA.1	26FC/2107	L.00847A	EA.1
	12 CE 237A	EA.1	26FC/2108	L.00848A	EA.1
26FC/2100	L.00727	EA.1		12 F 1311	EA.1
	12 CE 291A	EA.1		L.00851	EA.1
	12 F 1925	EA.1		L.00852	EA.1
	12 CE 313	EA.1		L.00579	EA.1
	12 CE 311	EA.1	26FC/2111	L.00711A	EA.1

PAGE EA.3

Ref. No.	Part No.	Plate No.	Ref. No.	Part No.	Plate No.
26FC/2102	L.00812A	EA.1	26FC/2096	L.00341	EA.1
	L.002709A	EA.1	26FC/2104	L.00849A	EA.1
26FC/3759	L.002344	EA.1		12 CE 245A	EA.1
26FC/3760	L.002345	EA.1	26FC/2119	L.00825	EA.1
	L.002829A/ND	EA.1	26FC/2120	L.00969	EA.1
	L.002713	EA.1		L.002298	EA.1
	L.002715	EA.1		L.002533	EA.1
	L.002721	EA.1		L.00733	EA.1
	L.002717	EA.1		L.00713A	EA.1
26FC/2103	L.00806	EA.1		L.003755	EA.1
				L.00734	EA.1

PAGE EA.4

Ref. No.	Part No.	Plate No.	Ref. No.	Part No.	Plate No.
	12 CE 227	EA.1		12CE 281	EA.1
	12 CE 229	EA.1		N.00267A	EA.1
26FC/2095	L.00737	EA.1	26FC/2090	L.00707	EA.1
26FC/2097	L.00336	EA.1		L.001397ND	EA.1
	12 CE 279	EA.1			

RESTRICTED

Issued with AL/2

PART 1

Venom FB Mk. 4

HAND INK ALTERATIONS

Insert in the "Plate No." Column the following plate numbers against the undermentioned Part Numbers :-

PAGE EB.1

Ref. No.	Part No.	Plate No.	Ref. No.	Part No.	Plate No.
27K/750	B.16658	EB.1	5250	12 CE 29A	EB.1
579	12 CE 27A	EB.1	5249	12 CE 33A	EB.1
2176	12 CE 75A	EB.1		L.001360A	EB.1
587	12 CE 171A	EB.1	27KB/16	AS.201/27P	EB.1
584	12 CE 115A	EB.1		12 CE 119	EB.1
7103	12 CE 73	EB.1		12 CE 121	EB.1
7102	12 CE 71	EB.1		12 CE 105	EB.1
7101	12 CE 69	EB.1		12 CE 107	EB.1

PAGE EB.2

Ref. No.	Part No.	Plate No.	Ref. No.	Part No.	Plate No.
581	12 CE 63A	EB.1	26BY/1931	L.98177	EB.1
582	12 CE 65A	EB.1	26BY/1920	L.98178	EB.1
583	12 CE 67A	EB.1	580	12 CE 53A	EB.1
26FC/2150	L.001216	EB.1	28A/1345	B.255	EB.1
2953	12 CE 61	EB.1	28A/1346	B.295	EB.1
8100	12 CE 357A	EB.1			
8099	12 CE 355A	EB.1			

PAGE EC.1

Ref. No.	Part No.	Plate No.	Ref. No.	Part No.	Plate No.
26FC/2613	J.00268	EC.1	26FC/2607	J.00255	EC.1
	12 CF 1031A/1	EC.1	4845	12 CF 373A	EC.1
	12 CF 1033A/1	EC.1		K.00343	EC.1
26FC/4625	J.001899	EC.1	26FC/3260	K.00344A	EC.1
26FC6694	12 CF 701	EC.1		K.00342	EC.1
26FC/3236	J.00602A	E.C.1	26FC/3270	K.00559A	EC.1
26FC/3235	J.00563	E.C.1	26FC/2597	J.00260A	EC.1
26FC/3237	J.00604	EC.1	26FC/2598	J.00267	EC.1

PAGE EC.2

Ref. No.	Part No.	Plate No.	Ref. No.	Part No.	Plate No.
	J.00266A	EC.1	224	12 CF 29	EC.1
26FC/3273	K.00360	EC.1	26FC/3262	K.00469A	EC.1
26FC/3275	K.00361	EC.1		K.00454	EC.1
	12 CF 465 ND	EC.1	26FC/3241	K.00371A	EC.1
26FC/3276	J.00238	EC.1	26FC/3242	K.00372	EC.1
	12 CF 435A	EC.1	28R/13514	AS.103	EC.1

PAGE EC.3

Ref. No.	Part No.	Plate No.	Ref. No.	Part No.	Plate No.
7702	12 CF 27A	EC.1	26FC/3620	K.00335A	EC.1
224	12 CF 29	EC.1		K.00378	EC.1
26FC/3265	K.00472A	EC.1	26FC/2495	K.00336A	EC.1
	K.00375	EC.1		12 CF 453A	EC.1
26FC/3239	K.00364	EC.1		12 CF 451A	EC.1
26FC/3243	K.00377A	EC.1	2739	12 CF 198A	EC.1

HAND INK ALTERATIONS

Insert in the "Plate No." Column the following plate numbers against the undermentioned Part Numbers :-

PAGE EC.4

Ref. No.	Part No.	Plate No.	Ref. No.	Part No.	Plate No.
2738	12 CF 197A	EC.1	26FC/3252	K.00258	EC.1
26FC/3248	K.00453A Mk. 25	EC.1	26FC/3328	K.00259	EC.1
26FC/3250	K.00453A Mk. 26	EC.1	26FC/3966	K.00577	EC.1
26FC/2692	K.00406A	EC.1	26FC/3257	K.00262	EC.1
26FC/3253	K.00263	EC.1	26FC/4700	J.001793A	EC.1
26FC/3254	K.00264	EC.1	26FC/4036	J.001791	EC.1
			26FC/4027	J.001791 Mk. 2	EC.1

PAGE EC.5

Ref. No.	Part No.	Plate No.	Ref. No.	Part No.	Plate No.
7712	12 CF 463	EC.1	26FC/3274	J.00875	EC.1
26FC/3269	K.00376	EC.1	1895	12 CF 725A	EC.1

PAGE ED.1

Ref. No.	Part No.	Plate No.	Ref. No.	Part No.	Plate No.
26FC/1661	K.0091A	ED.2		12 CF 75A	ED.3
	K.00593	ED.2	400	12 CF 83	ED.3
26FC/1653	K.0077	ED.2		12 CF 89ND	ED.3
26FC/3491	K.0075	ED.2	402	12 CF 85A	ED.3 & EG.1
324	12 CF 293	ED.1		K.00553	ED.3
323	12 CF 291	ED.1	6665	12 CF 447A	ED.3
7110	12 CF 445A	ED.3		12 CF 76A	ED.3

PAGE ED.2

Ref. No.	Part No.	Plate No.	Ref. No.	Part No.	Plate No.
401	12 CF 84	ED.2	7109	12 CF 229A	DE.3
	K.00554	ED.3		12 CF 919	ED.2
26FC/1686	K.00238	ED.3	26FC/1659	Q.0062	ED.1
26FC/2978	K.00539A	ED.3	26FC/1649	Q.0073	ED.1
26FC/1684	K.00540A	ED.3	26FC/1650	Q.0074	ED.1
7108	12 CF 227A	ED.3		12 CF 913	ED.2

PAGE ED.3

Ref. No.	Part No.	Plate No.	Ref. No.	Part No.	Plate No.
1504	12 CF 499	ED.1	26FC/1682	K.00237	ED.1
854	12 CF 339A	ED.1	26FC/1668	K.00193	ED.1
855	12 CF 347A	ED.1	26FC/1651	K.00203	ED.1
26FC/3750	K.0088/1	ED.1	9027	12 CF 789	ED.1
852	12 CF 343A	ED.1	9028	12 CF 791	ED.1
26FC/3749	K.0087/1	ED.1	7703	12 CF 335	ED.3
856	12 CF 355A	ED.1	7704	12 CF 336	ED.3
853	12 CF 351A	ED.1			

RESTRICTED

Issued with AL/2

PART 1

Venom FB Mk. 4

HAND INK ALTERATIONS

Insert in the "Plate No." Column the following plate numbers against the undermentioned Part Numbers :—

PAGE ED.4

Ref. No.	Part No.	Plate No.	Ref. No.	Part No.	Plate No.
7705	12 CF 337	ED.3	26FC/1657	K.00271A	ED.1
7706	12 CF 338	ED.3		12 CF 1051	ED.2
26FC/11542	K.00269A/1	ED.3	6527	12 CF 627	ED.2
26FC/3022	K.00550A	ED.3	26FC/1647	K.00298	ED.1
			26FC/1643	Q.0099	ED.1

PAGE ED.5

Ref. No.	Part No.	Plate No.	Ref. No.	Part No.	Plate No.
26FC/1642	Q.00598A	ED.1	26FC/1632	K.0079	ED.3
27W/7	UMC.703	ED.1		K.00973ND	ED.3
28W/1049	UMC.723	ED.1	26FC/1635	K.0063	ED.3
28W/1050	UMC.722	ED.1	26FC/4392	K.00588A	ED.3
28R/13515	AS.104	ED.2 & ED.3	26FC/4394	K.00590A	ED.3
	12 CF 1053A	ED.3	26FC/1638	K.0062	ED.3
	K.0068	ED.3	26FC/1634	K.0069	ED.3
	12 CF 1069ND	ED.3	26FC/1803	K.0041	ED.3

PAGE ED.6

Ref. No.	Part No.	Plate No.	Ref. No.	Part No.	Plate No.
26FC/1633	K.0076	ED.3	26FC/1622	K.00267	ED.2
26FC/1630	K.00302A	ED.1	26FC/1644	K.00280	ED.2
26FC/1631	K.00300	ED.1	26FC/1672	K.00214	ED.2
26FC/1629	K.0093A	ED.2	26FC/1665	K.00217	ED.2
26FC/1652	K.0082A	ED.2	26BY/14433	K.98646	ED.2
26FC/1663	K.00285	ED.2	26BY/14434	K.98647	ED.2
26FC/1662	K.00284	ED.2	6529	12 CF 617	ED.2
26FC/1623	K.00283	ED.2	6530	12 CF 907A	ED.2
				12 CF 909	ED.2

PAGE ED.7

Ref. No.	Part No.	Plate No.	Ref. No.	Part No.	Plate No.
6531	12 CF 911	ED.2	4746	12 CF 899	ED.2
	12 CF 935	ED.2	4751	12 CF 903	ED.2
4744	12 CF 885A	ED.2		12 CF 893	ED.2
4748	12 CF 891	ED.2	4749	12 CF 889	ED.2
4745	12 CF 895A	ED.2	4747	12 CF 905	ED.2
4750	12 CF 619	ED.2		12 CF 901	ED.2
	12 CF 887	ED.2	6528	12 CF 611	ED.2
	12 CF 955	ED.2	26FC/1628	K.0046A	ED.1

PAGE ED.8

Ref. No.	Part No.	Plate No.	Ref. No.	Part No.	Plate No.
8180	12 CF 1061A	ED.1	26FC/5869	K.0084	ED.1
	12 CF 1065	ED.1		12 CF 697A	ED.1
26FC/1625	K.0098A	ED.1	26FC/1806	K.00172	EE.1
	12 CF 677A	ED.1	1896	12 CF 695	ED.1
26FC/1645	K.0065A	ED.1	26FC/1646	K.0066A	ED.1
26FC/1660	K.0072	ED.1	27G/2014	AH.8241	ED.1
			1877	12 CF 649A	ED.1

HAND INK ALTERATIONS

Insert in the "Plate No." Column the following plate numbers against the undermentioned Part Numbers :—

PAGE EE.1

Ref. No.	Part No.	Plate No.	Ref. No.	Part No.	Plate No.
9026	12 CF 765	EE.1		12 CF 753	EE.1
26FC/1805	K.0052	EE.1		12 CF 743A	EE.1
26FC/1792	K.0053	EE.1	10299	12 CF 755A	EE.1
26FC/11767	K.0054	EE.1 & EF.1	27J/250	AC 1400	EE.1
6489	12 CF 957A	EE.1		12 CF 1007A/2	EE.1
26BY/3551	K.98593	EE.1	26FC/3682	K.00453A Mk. 22	EE.1
6488	12 CF 939	EE.1			

PAGE EE.2

Ref. No.	Part No.	Plate No.	Ref. No.	Part No.	Plate No.
26FC/1799	K.0037	EE.1	26FC/1802	K.0039	EE.1
26FC/1800	K.0038	EE.1	26FC/1795	K.0044	EE.1
26FC/1798	K.0064	EE.1	26FC/1790	K.0057	EE.1
26FC/1801	K.00231	EE.1	26FC/3492	K.00226	EE.1
26FC/1797	K.0040	EE.1	28A/1392	C.105	EE.1
26FC/11768	K.0042	EE.1 & EF.1		K.00223	EE.1
26FC/1803	K.0041	EE.1			

PAGE EF.1

Ref. No.	Part No.	Plate No.	Ref. No.	Part No.	Plate No.
	K.00908A/ND	EF.1	26FC/1783	K.00192A	EF.1
26FC/1785	K.00184	EF.1	26FC/1775	K.00199A	EF.1
26FC/1773	K.00185	EF.1	26FC/1786	K.00198	EF.1
26FC/1778	K.00171A	EF.1		K.00188	EF.1
26FC/1774	K.00163A	EF.1	26FC/1764	K.00167	EF.1
26FC/1789	K.00165	EF.1	26FC/1778	K.00169 Mk. 2	EF.1
26FC/1780	K.00164	EF.1	26FC/1777	K.00169 Mk. 1	EF.1
26FC/1781	K.00166	EF.1	26FC/1772	K.00170 Mk. 2	EF.1
26FC/1782	K.00191A	EF.1	26FC/1779	K.00170 Mk. 1	EF.1
			26BY/5976	H.11336	EF.1

PAGE EF.2

Ref. No.	Part No.	Plate No.	Ref. No.	Part No.	Plate No.
26FC/1771	K.00183	EF.1	26FC/1776	K.00200	EF.1
26FC/1784	K.00168	EF.1	26FC/1787	K.00210	EF.1
26FC/1766	K.00186	EF.1	26FC/1770	K.00197	EF.1
26FC/1765	K.00201	EF.1	26FC/1769	K.00196	EF.1
26FC/1767	K.00187	EF.1	26FC/1768	K.00194	EF.1
			26BY/3534	K.98297	EF.1

PAGE EG.1

Ref. No.	Part No.	Plate No.	Ref. No.	Part No.	Plate No.
3569	12 CF 243	EG.1	406	12 CF 97A	EG.1 & EG.3
3568	12 CF 241	EG.3		K.00323	EG.3
3567	12 CF 215	EG.3	2740	12 CF 443A/ND	EG.3
2736	12 CF 21A/ND	EG.3	7700	12 CF 18A/ND	EG.3
7701	12 CF 22A/ND	EG.3		12 CF 9	EG.3
	12 CF 19	EG.3		12 CF 10	EG.3
	12 CF 20	EG.3	406	12 CF 97A	EG.3

PAGE EG.2

Ref. No.	Part No.	Plate No.	Ref. No.	Part No.	Plate No.
405	12 CF 7	EG.3	26FC/2579	K.00115	EG.2
	K.00291	EG.3	2737	12 CF 193A	EG.2
7709	12 CF 429A/ND	EG.2	425	12 CF 177A	EG.2
	12 CF 11	EG.2	859	12 CF 353A	EG.2
28R/13514	AS.103	EG.2	26FC/3712	K.00465	EG.2
26FC/2583	K.00117 Mk. 1	EG.2	26FC/3714	K.00467	EG.2
26FC/2584	K.00117 Mk. 2	EG.2	26FC/2588	K.00149	EG.2
			26FC/2580	K.00152	EG.2

HAND INK ALTERATIONS

Insert in the "Plate No." Column the following plate numbers against the undermentioned Part Numbers :—

PAGE EG.3

Ref. No.	Part No.	Plate No.	Ref. No.	Part No.	Plate No.
26FC/2581	K.0099	EG.2	421	12 CF 167A	EG.2
26FC/2582	K.00100	EG.2	1791	12 CF 735A	EG.3
7708	12 CF 427A/ND	EG.2	1192	12 CF 385	EG.2
	12 CF 12	EG.2	1191	12 CF 387	EG.2
1190	12 CF 407A	EG.2	5808	12 CF 195A/1	EG.2
7707	12 CF 389A	EG.2	860	12 CF 357A	EG.2
422	12 CF 169A	EG.2	425	12 CF 177A	EG.2
857	12 CF 349A	EG.2	420	12 CF 165A	EG.2
			859	12 CF 353A	EG.2

PAGE EG.4

Ref. No.	Part No.	Plate No.	Ref. No.	Part No.	Plate No.
26FC/5384	K.00934	EG.2	1295	12 CF 473	EG.3
26FC/5383	K.00933	EG.2	411	12 CF 141ND	EG.1
1476	12 CF 481	EG.2	412	12 CF 142ND	EG.1
1475	12 CF 479	EG.2	409	12 CF 139ND	EG.1
1189	12 CF 419	EG.2	410	12 CF 140ND	EG.1
3570	12 CF 155A	EG.1	2941	12 CF 769	EG.1
	12 CF 163	EG.1	2942	12 CF 770	EG.1
			2939	12 CF 767	EG.1

PAGE EG.5

Ref. No.	Part No.	Plate No.	Ref. No.	Part No.	Plate No.
2940	12 CF 768	EG.1	3571	12 CF 265	EG.1
2739	12 CF 198A	EG.3	1296	12 CF 475	EG.3
2738	12 CF 197A	EG.3	1297	12 CF 477	EG.3
27K/568	B.29140	EG.3	417	12 CF 281ND	EG.1
7713	12 CF 989ND	EG.3	576	12 CF 117A	EG.1
7714	12 CF 991ND	EG.3	408	12 CF 133A	EG.1
27K/—	B.10699	EG.3	398	12 CF 153A	EG.1
27K/—	B.10700	EG.3	399	12 CF 161	EG.1

PAGE EG.6

Ref. No.	Part No.	Plate No.	Ref. No.	Part No.	Plate No.
868	12 CF 365A	EG.1	402	12 CF 85A	EG.1
408	12 CF 133A	EG.1	576	12 CF 117A	EG.1
			406	12 CF 97A	EG.1

PAGE EG.7

Ref. No.	Part No.	Plate No.
868	12 CF 365A	EG.1

This file was downloaded
from the RTFM Library.

Link: www.scottbouch.com/rtfm

Please see site for usage terms,
and more aircraft documents.

