

PIPES AND FITTINGS IN FUSELAGE AND AT ENGINE

Ref. No.	Part No.	Nomenclature						No. Off	M,R.	Cl. of St.	Plate No.
		1	2	3	4	5	6				
	—	<b>PIPES AND FITTINGS IN FUSELAGE AND AT ENGINE (12 P 23)</b>						1	—		H.1
28V/6744	AGS.908/BB	<b>ADAPTOR</b> , at main tank for drain pipe ... ..						1	—	C.	
28F/9708	AGS.1104/B	<b>ADAPTOR</b> , cone, at main tank, for drain pipe ... ..						1	—	C.	
	2849	12 P 973						1	—	C.	H.1
26FC/1819	P.00166	<b>ADJUSTER</b> , for tank strap ... ..						1	—	C.	H.2
26FC/3945	A.004224ND	<b>BLOCK</b> , rubbing, at top of tank, front ... ..						1	—	C.	
	1480	12 F 911						1	—	C.	H.2
28D/8306	AS.1242/1C	<b>BOLT</b> , 2 BA, for clips securing vent ... ..						8	—	C.	
28D/12513	A25/2C	<b>BOLT</b> , 2 BA, pipes to engine mounting frame for clips securing vent pipes						2	—	C.	
28D/8309	AS.1242/4C	<b>BOLT</b> , 2 BA, for securing pipe clip to cowl rail ... ..						2	—	C.	
	7718	12 F 597A						1	MR	C.	H.2
26FC/3772	P.002784A	<b>BRACKET</b> , support, for main tank ... ..						2	—	C.	H.2
		Attaching parts for P.002784A, Bracket :—									
28E/8185	AGS.605/3	Clip ... ..						2	—	C.	
	5771	12 P 529						8	—	C.	H.1
		<b>CLAMP</b> , half, for fuel feed connection on fuselage side, rear of fireproof bulkhead (Mod. Ven. 100) (Pre Mod. Ven. 563)									
		Attaching parts for 12 P 529, Clamp :—									
	5875	DHS.400/14E						2	—	C.	
28M/10290	AGS.2001/E/1	Nut, 1/2" BSF ... ..						2	—	C.	
28W/12253	SP.13/E	Washer ... ..						2	—	C.	
	8107	T. BOORN & Co. F/S.6000/1						4	—	C.	H.1
		<b>CLAMP</b> , " Fly clamp " for fuel pipe (Mod. Ven. 563)									
		DHS.31 Mk. 49						2	—		
28E/8182	AGS.605/0	<b>CLIP</b> ... ..						4	—	C.	
28E/8183	AGS.605/1	<b>CLIP</b> ... ..						34	—	C.	
		12 P 869ND						1	—		
		<b>CLIP</b> , for fuel transfer pipe secured to low pressure cock Teleflex box, 20 SWG, Spec. S.3									
28E/14083	AS.3181/12C	<b>CLIP</b> , for securing feed pipe to cant rail ... ..						2	—	C.	
28E/14239	AS.3181/24C	<b>CLIP</b> , for securing pressure pipe from drop tank to engine mounting						2	—	C.	
28E/14191	AS.3181/8C	<b>CLIP</b> , securing pressure pipe from drop tank to engine mounting						2	—	C.	
		Attaching parts for AS.3181/24C and AS.3181/8C, Clips :—									
28D/12512	A25/1C	Bolt, 2 BA ... ..						2	—	C.	
28M/10288	AGS.2001/C/1	Nut, 2 BA ... ..						2	—	C.	
28W/12252	SP.13/C	Washer ... ..						2	—	C.	
		DHS.31 Mk. 31						3	—		
		<b>CLIP</b> , tubular ... ..									
		AS.3360/C7E						2	—		
1545	12 P 319A	<b>CONNECTOR</b> , bonding, for tank strap ... ..						1	—	C.	H.1
483	12 S 41A	<b>CONNECTION</b> , transfer, at bulkhead ... ..						1	—	C.	H.1
10144	12 S 1861	<b>CONNECTION</b> , vent, at bulkhead (Pre Mod. Ven. 806)						1	—	C.	H.1
		<b>CONNECTION</b> , vent at bulkhead (Mod. Ven. 806)						1	—	C.	H.1
		Attaching parts for 12 S 1861, Connection :—									
	8107	T. BOORN & Co. FS/6000/1						1	—	C.	
		Clamp, flyclamp ... ..									
10345	T. BOORN & Co. FS/6010/01	Nipple... ..						1	—	C.	
	484	12 S 43						1	—	C.	
		<b>CONNECTION</b> , vent, from main tank (Pre Mod. Ven. 806)									
10143	12 S 1863	<b>CONNECTION</b> , vent, top, for main tank (Mod. Ven. 806)						1	—	C.	
		DHS.160/B/25						2	—		
		<b>COUPLING</b> , 1/2" i/d x 2.5" long, DTD.625 ... ..									
		(Make from 32C/408)									
		DHS.160/D/25						4	—		
		<b>COUPLING</b> , 3/4" i/d x 2.5" long, DTD.625 ... ..									
		(Make from 32C/375)									

FUEL SYSTEM

PIPES AND FITTINGS IN FUSELAGE AND AT ENGINE

Ref. No.	Part No.	Nomenclature						No. Off	M.R.	Cl. of St.	Plate No.
		1	2	3	4	5	6				
	DHS.160/F/20	COUPLING, 1-0" i/d x 2-0" long, DTD.625 ...						QR	—		
	DHS.160/F/25	COUPLING, 1-0" i/d x 2-5" long, DTD.625 ...						QR	—		
	DHS.160/G/25	COUPLING, 1 1/8" i/d x 2-5" long, DTD.625 ...						2	—		
	DHS.160/G/30	COUPLING, 1 1/8" i/d x 3-0" long, DTD.625 ...						1	—		H.2
8215	12 P 531	COUPLING, flange, for fuel feed connection on fuselage side, rear of fireproof bulkhead						2	—	C.	H.1
5895	12 P 533	COUPLING, flange, for fuel feed connection on fuselage side rear of fireproof bulkhead						4	—	C.	H.1
28V/3786	AGS.627/H	COUPLING, pipe... ..						2	—	C.	
26FC/1891	A.001258A	DOOR, for main tank filler cap ... ..						1	—	C.	H.2
27FP/92	DZUS F6 3/160	FASTENER ... ..						1	—	C.	
27FP/298	DZUS GF.6 1/2/250	GROMMET ... ..						1	—	C.	
28L/13140	A.27/BT	LOCKNUT, 4 BA ... ..						1	—	C.	
	E.98239 Mk. 2	PLATE, catch, 16 SWG, spec. S.84... ..						1	—		H.2
		(Make from Air Ministry Ref. No. 30A/2161)									
28S/2815	A33/B16	SCREW, 4 BA ... ..						1	—	C.	
28W/12305	SP.13/B	WASHER ... ..						1	—	C.	
	—	FILTER, gauze, copper, 16 mesh, 28 SWG ... ..						QR			
		(cut as required)									
26FC/11774	DHS.209/5	GUARD, clip ... ..						8	—	C.	
28F/10526	AGS.1142/BB	NIPPLE, drain pipe from main tank ... ..						1	—	C.	
28N/10180	AGS.209/L	NIPPLE, for feed pipes ... ..						6	—	C.	
28N/10722	AGS.209/M	NIPPLE, for feed pipes ... ..						4	—	C.	
28F/9619	AGS.1142/C	NIPPLE, for pipe from drop tank pressure reducing valves						2	—	C.	
28M/10288	AGS.2001/C/1	NUT, 2 BA, for pipe clip bolts... ..						12	—	C.	
	P.00231	PIECE, packing, at main tank filler cap door 16 SWG, L.72 (Make from 30B/1728)						1	—		H.2
7888	12 P 1151A/ND	PIPE, drain from main tank (Mod. Ven. 576)... ..						1	—	C.	
4851	12 P 549A/ND	PIPE, feed, from fireproof bulkhead, L.H. ... ..						1	—	C.	H.1
		(Pre Mod. Ven. 671)									
2945	12 P 575A/ND	PIPE, feed, for fireproof bulkhead, R.H. ... ..						1	—	C.	H.1
		(Pre Mod. Ven. 671)									
9249	12 S 1815A/ND	PIPE, feed from fireproof bulkhead to No. 1 tank, Port (Mod. Ven. 671)						1	—	C.	H.1
9250	12 S 1817A/ND	PIPE, feed from fireproof bulkhead to No. 1 tank, Starboard (Mod. Ven. 671)						1	—	C.	H.1
7317	12 P 1137A	PIPE, flexible, feed from fireproof bulkhead to main tank L.H. (Mod. Ven. 558)						1	—	C.	H.2
1698	12 P 603A	PIPE, flexible, feed, from fireproof bulkhead to main tank, L.H. (Pre Mod. Ven. 558)						1	—	C.	H.2
896	12 P 279A	PIPE, flexible, feed, from fireproof bulkhead to main tank, R.H.						1	—	C.	H.2
894	12 P 277A	PIPE, flexible, supply, from main tank to fireproof bulkhead						1	—	C.	H.2

PIPES AND FITTINGS IN FUSELAGE AND AT ENGINE

Ref. No.	Part No.	Nomenclature						No Off	M,R.	Cl. of St.	Plate No.
		1	2	3	4	5	6				
466	12 P 21A	PIPE, flexible, supply, from fireproof bulkhead to low pressure filter						1	—	C.	H.1
7127	12 P 1123ND	PIPE, from drop tank pressure reducing valve, L.H.						1	—	C.	H.1
7126	12 P 1121ND	PIPE, from drop tank pressure reducing valve, R.H.						1	—	C.	H.1
1546	12 P 329ND	PIPE, transfer, from fireproof bulkhead to rib No. 1, L.H.						1	—	C.	H.1
480	12 P 151ND	PIPE, transfer, from fireproof bulkhead to rib No. 1, R.H.						1	—	C.	H.1
6644	12 S 1469A/ND	PIPE, vent, from fireproof bulkhead to joint, L.H. (Mod. Ven. 426)						1	—	C.	H.1
6026	12 S 1423A/ND	PIPE, vent, from fireproof bulkhead to joint, R.H.						1	—	C.	H.1
	12 S 1789A	PIPE, vent, lower from main tank (Mod. Ven. 551)						1	—	C.	H.1
8762	12 S 1751	ADAPTOR ... ..						1	—	C.	
28E/8184	AGS.605/Mk. 2	CLIP ... ..						2	—	C.	
	DHS.160/H/70	COUPLING, 1 1/4" i/d x 7.0" long, DTD.625 ...						1	—	C.	
8764	12 S 1759	PIPE ... ..						1	—	C.	
6600	E.98234 Mk. 2	PLATE, catch, for main tank filler cap door ...						1	—	C.	H.2
462	12 F 195	PLATE, retaining, at bulkhead, for top vent connection Attaching parts for 12 F 195, Plate :—						1	MR	C.	H.1
28D/12511	A25/2B	Bolt, 4 BA ... ..						4	MR	C.	
891	12 P 271	PLATE, retaining, at bulkhead, for transfer connection adaptor Attaching part for 12 P 271, Plate :—						1	MR	C.	H.1
28D/12511	A25/2B	Bolt, 4 BA ... ..						4	MR	C.	
26BY/270	E.98233A	PLATE, spring, for main tank filler cap door ...						1	—	C.	H.2
27FP/345	DZUS S.6/425	SPRING ... ..						1	—	C.	
7278	12 P 205A	PLATE, support, for main tank ... .. Attaching parts for 12 P 205A, Plate :—						1	MR	C.	H.2
28D/12518	A25/2E	Bolt, 1/2" BSF ... ..						2	—	C.	
28M/10290	AGS.2001/E/1	Nut, 1/2" BSF ... ..						2	—	C.	
28W/12253	SP.13/E	Washer ... ..						2	—	C.	

FUEL SYSTEM

PIPES AND FITTINGS IN FUSELAGE AND AT ENGINE

Ref. No.	Part No.	Nomenclature						No. Off	M.R.	Cl. of St.	Plate No.
		1	2	3	4	5	6				
28F/10482	AGS.1140/A	<b>PLUG</b> , nipple, at adaptor on vent pipe joint piece						1	—	C.	
5883	DOWTY SP.910/22	<b>RING</b> , "O," for fuel feed connection on fuselage side, rear of fireproof bulkhead						4	—	C.	H.1
461	12 F 193	<b>RING</b> , sealing, at bulkhead, for top vent connection						1	MR	C.	H.1
470	12 P 71	<b>RING</b> , sealing, at bulkhead, for transfer connection						1	MR	C.	H.1
2936	12 P 535	<b>RING</b> , split for fuel feed connection on fuselage side, rear of fireproof bulkhead						4	—	C.	H.1
28F/5721	AGS.904/A	<b>SLEEVE</b> , outer, at adaptor on vent pipe joint piece						1	—	C.	
26FC/1973	P.00333A	<b>STRAP</b> , for main tank ... ..						2	—	C.	
28D/	A25/26G	Attaching parts for P.00333A, Strap :—									
26FC/1886	P.00165	Bolt, $\frac{5}{16}$ " BSF ... ..						1	—	C.	
28M/13122	A27/GS	Bush ... ..						3	—	C.	
	P.001150	Nut, $\frac{5}{16}$ " BSF ... ..						1	—	C.	
	P.001151	<b>STRAP</b> , for securing drain pipe from main tank, 20 SWG, L.72						1	—		
		Attaching parts for P.001150, Strap :—									
		Block, support, 0".75 wide x 0.4" thick x 0."84 long, LFS.21						1	—		
28D/12429	A25/4B	Bolt, 4 BA ... ..						1	—	C.	
28M/13086	A27/BP	Nut, 4 BA ... ..						1	—	C.	
6A/1912	—	<b>SWITCH</b> , fuel pressure warning ... ..						1	—	B.	
	12 PT 773A/7	<b>TANK</b> (See Separate Unit) (Alternative to 12 PT 774A/4)						1	—		
	12 PT 774A/4	<b>TANK</b> (See Separate Unit) (Alternative to 12 PT 773A/7)						1	—		
26FC/1929	P.00163	<b>TRUNNION</b> , tank strap, L.H. thread ... ..						1	—	C.	H.2
26FC/1930	P.00164	<b>TRUNNION</b> , tank strap, R.H. thread ... ..						1	—	C.	H.2
28F/11198	AGS.1103/D	<b>UNION</b> , body, for pressure pipe from drop tank						1	—	C.	
1699	12 P 757	<b>WASHER</b> , booster pump outlet ... ..						1	—	C.	
28F/8215	AGS.1138/B	<b>WASHER</b> , jointing at main tank drain pipes ...						2	—	C.	
2384	DOWTY SP.837/ Mk. 29B	<b>WASHER</b> , sealing, rubber, at main tank top vent connection						1	—	C.	
2383	DOWTY SP.837/ Mk. 27B	<b>WASHER</b> , sealing, rubber, at transfer connection to main tank						1	—	C.	
4067	12 P 853	<b>WASHER</b> , tailed, at transfer connection on fireproof bulkhead						1	—	C.	H.1
4071	12 S 1085	<b>WASHER</b> , tailed, at vent connection on fireproof bulkhead (Pre Mod. Ven. 806)						1	—	C.	H.1
28F/9655	AGS.1138/J	<b>WASHER</b> , jointing, at lower main tank vent (Mod. Ven. 551)						1	—	C.	

FUEL SYSTEM  
FUSELAGE TANK

Ref. No.	Part No.	Nomenclature						No Off	M.R.	Cl. of St.	Plate No.
		1	2	3	4	5	6				
	12 PT 773A/7	<b>TANK, FUSELAGE</b> (Alternative to 12 PT 774A/4) (Mod. Ven 733)						1	—		HA.1
	12 PT 774A/4	<b>TANK, FUSELAGE</b> (Alternative to 12 PT 773A/7) (Mod Ven. 739)						1	—		HA.1
5UE/4983	PB.3 Mk. 3	<b>PUMP, booster,</b> Self Priming Pumps (Alternative to 5UE/5639, Pulsometer, 403 Mk. 1)						1	—	A.	
5UE/5639	POL.403 Mk. 1	<b>PUMP, booster,</b> Pulsometer (Alternative to 5UE/4983, Self Priming Pump, BP.3 Mk. 3)						1	—	A.	
8834	12 PT 1801A/ND	<b>TANK</b> ... ..						1	—	A.	
28F/12747	AGS.1105/J	<b>ADAPTOR,</b> for booster pump support base connections						3	—	C.	HA.2
26FC/2266	P.0058	<b>ADAPTOR,</b> for fuel feed manifold						1	—	C.	HA.2
1702	12 PT 1191	<b>BASE,</b> booster pump support						1	MR	C.	HA.2
		Attaching parts for 12 PT 1191, Base :—									
26FC/2267	P.00219	Bolt, for drain plug						1	—	C.	HA.2
28M/10288	AGS.2001/C/1	Nut, 2 BA						17	MR	C.	
28W/12253	SP.13/C	Washer						17	MR	C.	
28D/12514	A25/7C	<b>BOLT,</b> 2 BA, with head drilled No. 54 for locking wire, for securing booster pump						12	—	C.	
28D/12707	A25/1E	<b>BOLT,</b> 1/4" BSF, for use in extractor bolt holes in booster pump plate						4	—	C.	
26FC/2958	P.001152A	<b>CAP,</b> filler						1	—	C.	HA.1
28N/3721	AGS.607/D	<b>CHAIN,</b> retaining						QR	—	C.	
28M/13086	A27/BP	<b>NUT,</b> 4 BA						4	—	C.	
	P.001155A	<b>PLATE,</b> backing						1	—	C.	HA.1
26FC/2959	P.001157	<b>PLATE,</b> cover						1	—	C.	HA.1
	P.001156	<b>PLATE,</b> swivel, for retaining chain						1	—	C.	HA.1
26BY/6376	691218	<b>RING,</b> locking						1	—	C.	HA.1
28S/2875	A32/B24	<b>SCREW,</b> 4 BA						4	—	C.	
26FC/2290	P.00327	<b>SPRING,</b> valve						1	—	C.	HA.1
26FC/2960	P.001154	<b>VALVE</b>						1	—	C.	HA.1
28W/12252	SP.13/B	<b>WASHER</b>						2	—	C.	
28E/8184	AGS.605/2	<b>CLIP</b>						2	—	C.	
1703	12 PT 1201A	<b>GUIDE,</b> vapour						1	MR	C.	HA.2
		Attaching parts for 12 PT 1201A, Guide :—									
28D/12516	A25/11C	Bolt, 2 BA						1	MR	C.	
28D/12714	A25/29C	Bolt, 2 BA						3	MR	C.	
28M/10288	AGS.2001/C/1	Nut, 2 BA						4	MR	C.	
28W/12253	SP.13/C	Washer						4	MR	C.	
555	12 PT 813ND	<b>HOSE,</b> 1 1/4" i/d x 4-5" long, Flyite...						1	—		HA.2
28M/12929	12 PT 133A	<b>MANIFOLD,</b> fuel feed						1	MR	C.	HA.2
28M/10288	A27/CP	<b>NUT,</b> 2 BA, at booster pump securing stud						2	—	C.	
1700	AGS.2001/C/1	<b>NUT,</b> 2 BA, attaching fuel contents transmitter...						12	—	C.	
1701	12 PT 1289A	<b>PIPE,</b> from feed hose at booster pump support base						1	MR	C.	HA.2
26FC/3300	12 PT 1295	<b>PLATE,</b> bolt, front, for booster pump						1	—	C.	HA.2
	P.002289A	<b>PLATE,</b> bolt, rear, for booster pump						1	—	C.	HA.2
		Attaching parts for 12 PT 1295 and P.002289A, Plates :—									
28S/2815	A33/B16	Screw, 4 BA						4	—	C.	
26FC/330	P.002285A	<b>PLATE,</b> bolt, side for booster pump						2	—	C.	HA.2
		Attaching parts for P.002285A, Plate :—									
28S/2815	A33/B16	Screw, 4 BA						5	—	C.	
552	12 PT 21	<b>PLATE,</b> cover, at fuel contents transmitter locating spigot						1	MR	C.	HA.1
		Attaching parts for 12 PT 21, Plate									
28D/8342	AS.1248/2C	Bolt, 2 BA						8	MR	C.	

FUEL SYSTEM  
FUSELAGE TANK

Ref. No.	Part No.	Nomenclature						No. Off	M.R.	Cl. of St.	Plate No.
		1	2	3	4	5	6				
2291	12 PT 1427A	<b>PLATE</b> , mounting, complete with sealing ring, at filler neck						1	—	C.	HA.1
26FC/6890	12 PT 1429	<b>RING</b> , sealing ... ..						1	—	C.	HA.1
501	12 PT 77A	<b>PLATE</b> , nut, for booster pump ... ..						2	—	C.	HA.2
502	12 PT 79A	<b>PLATE</b> , nut, for booster pump ... ..						1	—	C.	HA.2
		Attaching parts for 12 PT 77A and 12 PT 79A, Plates :—									
28M/10287	AGS.2001/B/1	Nut, 4 BA ... ..						2	—	C.	
28S/2139	A45/B24	Screw, 4 BA ... ..						2	—	C.	
554	12 PT 29A	<b>PLATE</b> , spigot, for fuel contents transmitter ...						1	MR	C.	HA.1
8095	12 P 1173	<b>PLUG</b> , blanking, for branch feed pipes (Mod. Ven. 607)						2	—	C.	HA.1
28R/8178	AGS.565/B	<b>PLUG</b> , drain (Mod. Ven. 571) ... ..						3	—	C.	
28R/10847	AGS.566/D	<b>PLUG</b> , drain, at booster pump support base ...						1	—	C.	
26BY/2542	L.981552	<b>PLUG</b> , drain, at booster pump support base drain bolt						1	—	C.	HA.2
28R/1400	AGS.216/F	<b>PLUG</b> , drain, at fuel feed manifold ... ..						1	—	C.	
8096	12 PT 1781	<b>PLUG</b> , nipple for blanking rear fuel connection No. 1 tank (Make from AGS.1197/H) (Mod. Ven. 606)						2	—	C.	HA.1
		Attaching parts for 12 PT 1781, Plug :—									
28P/12349	SP.9/C5	Pin, split ... ..						2	—	C.	
28F/11685	AGS.954/H	Sleeve, outer ... ..						2	—	C.	
1705	12 PT 1303	<b>RESERVOIR</b> , fuel, for inverted flight ... ..						1	—	C.	HA.2
26BY/1020	P.98301	<b>RING</b> , adaptor, for filler cap ... ..						1	—	C.	HA.1
		Attaching parts for P.98301, Ring :—									
28M/10288	AGS.2001/C/1	Nut, 2 BA ... ..						8	—	C.	
28W/12296	SP.15/C	Washer ... ..						8	—	C.	
893	12 PT 615A	<b>RING</b> , bolt, half, for float valve ... ..						2	MR	C.	HA.2
		Attaching parts for 12 PT 615A, Rings :—									
28D/8302	AS.1242/3B	Bolt, 2 BA ... ..						2	MR	C.	HA.1
26FC/2287	P.00154A	<b>RING</b> , bolt, half, for fuel contents transmitter						2	—	C.	
		Attaching parts for P.00154A, Ring :—									
28S/2815	A33/B16	Screw, 4 BA ... ..						2	—	C.	
558	12 PT 805A	<b>RING</b> , bolt, L.H., half, for filler cap adaptor ...						1	MR	C.	HA.1
559	12 PT 806A	<b>RING</b> , bolt, R.H., half, for filler cap adaptor ...						1	MR	C.	HA.1
		Attaching parts for 12 PT 805A and 12 PT 806A, Rings :—									
28S/2815	A33/B16	Screw, 4 BA ... ..						2	MR	C.	

FUEL SYSTEM  
FUSELAGE TANK

Ref. No.	Part No.	Nomenclature						No. Off	M.R.	Cl. of St.	Plate No.
		1	2	3	4	5	6				
1704	12 PT 1207							1	MR	C.	HA.2
28D/8313	AS.1242/9C							2	MR	C.	
28M/10288	AGS.2001/C/1							2	MR	C.	
28W/12252	SP.13/C							1	MR	C.	
	12 PT 771A/3							1	MR	C.	HA.1
	12 PT 771A/2							1	MR	C.	HA.1
514	12 PT 601							1	MR	C.	HA.1
26FC/2277	P.00150							1	MR	C.	HA.1
26BY/7985	P.98172							1	MR	C.	HA.1
	DHS.30 Mk. 25							1	—		
	12 PT 605							1	—		
	12 PT 785							3	—		HA.1
516	12 PT 727							1	MR	C.	HA.1
28M/10298	AGS.2001/C/2							116	—	C.	HA.1
	12 PT 1293							1	MR	C.	HA.2
26BY/8271	P.98405							1	MR	C.	
890	12 PT 613							1	MR	C.	HA.1
512	12 PT 23A							1	MR	C.	HA.1
26FC/4263	P.003283							1	MR	C.	
28S/6611	A37/C20							116	—	C.	
	12 PT 1193							116	—		
	12 PT 1195							116	—		
28W/12296	SP.15/C							116	—	C.	
26FC/2279	P.00152							1	—	C.	HA.1
28M/10288	2001/C/G1							2	—	C.	
28T/2920	AGS.884/F							2	—	C.	
28Y/14099	AS.2560							1	MR	C.	
28D/8507	AS.1242/5C							12	MR	C.	
27F/2498	SELF PRIMING PUMPS FV.1253/S/Mk.1							1	—	A.	
28M/10288	AGS.2001/C/1							12	—	C.	
28W/12252	SP.13/C							12	—	C.	
2883	12 PT 1517A							3	MR	C.	HA.2
	12 PT 127ND							2	MR	C.	HA.2
	12 PT 1515							1	MR	C.	HA.2
28M/13086	A27/BP							1	MR	C.	HA.2
	12 PT 1512							1	MR	C.	HA.2
28S/2809	A33/B12							1	MR	C.	HA.2
2884	12 PT 1511							1	MR	C.	HA.2
	12 PT 1519							1	MR	C.	HA.2
	12 PT 1521							1	MR	C.	HA.2
26FC/3303	P.002405A							1	—	C.	HA.2
26FN/1388	4 PT 45							1	—	C.	HA.2
28D/12636	A25/5B							2	—	C.	
28D/12533	A25/5C							2	—	C.	

FUEL SYSTEM  
FUSELAGE TANK

Ref. No.	Part No.	Nomenclature						No. Off	M.R.	Cl. of St.	Plate No.
		1	2	3	4	5	6				
507	12 PT 105A							2	MR	C.	HA.2
	12 PT 107A							1	MR	C.	HA.2
	12 AT 1159							1	MR		HA.2
	12 PT 109ND							1	MR		HA.2
	12 PT 113ND							1	MR		HA.2
508	12 PT 111ND							1	MR	C.	HA.2
509	12 PT 345							1	MR	C.	HA.2
								Attaching parts for 12 PT 105A, Valve :—			
28M/10288	AGS.2001/C/1							4	MR	C.	
28S/2838	A33/C32							4	MR	C.	
510	12 PT 123							1	MR	C.	HA.2
28W/12253	SP.13/C							4	MR	C.	
8092	DHS.204/E							8	MR	C.	
28F/9655	AGS.1138/J							5	—	C.	
26FC/3317	P.002287							1	—	C.	HA.2
26FC/3316	P.002286							1	—	C.	HA.2
26FC/3297	P.002290							2	—	C.	HA.2
26FC/3298	P.002291							2	—	C.	HA.2
28F/8215	AGS.1138/B							3	—	C.	
28F/8225	AGS.1138/A							1	—	C.	
26BY/1021	691234							1	—	C.	HA.1
2292	12 PT 1433							2	—	C.	HA.1
26BY/6379	P.9895							1	—	C.	HA.1
887	12 PT 623							1	—	C.	HA.2
889	12 PT 607							1	—	C.	HA.2
556	12 PT 443							1	—	C.	HA.1
553	12 PT 27							1	—	C.	HA.1
28F/9653	AGS.1138/F							1	—	C.	
26FC/3296	P.002406							1	—	C.	HA.2
505	12 PT 101							1	MR	C.	HA.2
503	12 PT 85							2	—	C.	HA.2
28W/12253	SP.13/C							14	—	C.	
6A/2925	SIMMONDS GP. 352/084							1	—	A.	HA.1

PIPES AND FITTINGS IN WING

Ref. No.	Part No.	Nomenclature						No. Off	M.R.	Cl. of St.	Plate No.
		1	2	3	4	5	6				
		<b>PIPES AND FITTINGS IN WING, PORT</b> ...						-	-		
		(12 P 975)									
		<b>PIPES AND FITTINGS IN WING, STARBOARD</b>						-	-		
		(12 P 976)									
655	12 S 143A	<b>ADAPTOR</b> , at rib No. 6, for vent pipes between tanks No. 2 and No. 3, Port						1	-	C.	HB.1
656	12 S 144A	<b>ADAPTOR</b> , at rib No. 6, for vent pipes between tanks No. 2 and No. 3, Starboard						1	-	C.	HB.1
		Attaching parts for 12 S 143A and 12 S 144A, Adaptors :-									
28D/12513	A25/2C	Bolt, 2 BA ... ..						3	-	C.	
28M/12088	AGS.2001/C/1	Nut, 2 BA ... ..						2	-	C.	
28W/12252	SP.13/C	Washer ... ..						3	-	C.	
6A/3822	SIMMONDS GP.31010	<b>ADAPTOR</b> , for fuel contents gauge tank unit, tank No. 1, Pacitor						1	-	A.	HB.2
663	12 W 2595	<b>BLOCK</b> , clamp, for pipes at rear of undercarriage diaphragm, rib No. 4						1	-	C.	HB.1
		Attaching parts for 12 W 2595, Block :-									
28D/12513	A25/2C	Bolt, 2 BA ... ..						4	-	C.	HB.1
	12 W 2597	Strap, clamp block at rear of undercarriage diaphragm, rib No. 4, 2-05" long x 0-5" wide x 18 SWG, L.72						2	-		
664	12 W 2599	<b>BLOCK</b> , clamp, half, for pipes at rear of undercarriage diaphragm, rib No. 3						2	-	C.	HB.1
		Attaching parts for 12 W 2599, Block :-									
28D/12513	A25/2C	Bolt, 2 BA ... ..						2	-	C.	
28W/12252	SP.13/C	Washer ... ..						2	-	C.	
	12 P 229ND	<b>BLOCK</b> , rubbing, sponge K/R, under feed pipe from tank No. 1 to tank No. 2, tank No. 2 to tank No. 3, tank No. 3 to tank No. 4						5	-		HB.1
646	12 S 25	<b>BLOCK</b> , sealing on rib No. 1, at vent connection, tank No. 1						2	-	C.	HB.2
		Attaching parts for 12 S 25, Block :-									
28D/12512	A25/1C	Bolt, 2 BA ... ..						1	-	C.	
	12 P 939A	<b>BRACKET</b> , mounting reducing valve, Port ... ..						1	-		HB.3
	12 P 940A	<b>BRACKET</b> , mounting reducing valve, Starboard ... ..						1	-		HB.3
		Attaching parts for 12 P 939A and 12 P 940A, Brackets :-									
28D/8306	AS.1242/1C	Bolt, 2 BA ... ..						2	-	C.	
	12 P 967A	<b>BRACKET</b> , mounting reducing valve located near false spar						1	-		HB.3
		Attaching parts for 12 P 967A, Bracket :-									
28D/8306	AS.1242/1C	Bolt, 2 BA ... ..						2	-	C.	
8323	12 P 1029	<b>BRACKET</b> , supporting "P" clip, Port ... ..						1	-	C.	HB.3
8324	12 P 1030	<b>BRACKET</b> , supporting "P" clip, Starboard ... ..						1	-	C.	HB.3

FUEL SYSTEM

PIPES AND FITTINGS IN WING

Ref. No.	Part No.	Nomenclature						No. Off	M.R.	Cl. of St.	Plate No.
		1	2	3	4	5	6				
	12 P 693A	<b>BRACKET</b> , supporting (Teddington type non-return valve)						1	—		HB.3
28D/10168	AS.1242/11C	Attaching parts for 12 P 693A, Bracket :— Bolt, 2 BA ... ..						2	—	C.	
610	12 PT 445A	<b>CAGE</b> , filler for tank No. 1 and No. 4 ... ..						2	—	C.	HB.2
26FC/4314	MARSTON BM.1593/14	<b>CAP</b> , filler for tank No. 1 and No. 4 ... ..						2	—	C.	HB.2
26FC/4237	MARSTON CM.1962	<b>CAP</b> ... ..						1	—	C.	HB.2
28N/3721	AGS.607/D	<b>CHAIN</b> , retaining ... ..						1	—	C.	
28N/12729	AGS.2031/9	<b>CIRCLIP</b> , external, for 0.72" dia. spindle for retaining collar (Seeger)						1	—	C.	
26FC/4238	MARSTON CM.1994	<b>COLLAR</b> , retaining chain attachment ... ..						1	—	C.	HB.2
28N/3724	AGS.609/B	<b>RING</b> , locking ... ..						1	—	C.	
26FC/6414	MARSTON BM.1593/9	<b>RING</b> , seating ... ..						1	—	C.	HB.2
28N/12728	AGS.2031 Mk. 12	<b>CIRCLIP</b> , for fuel pipe connection at manifold, wing tip						4	—	C.	
5627	DUNLOP DAS.185/06	<b>CLIP</b> ... ..						1	—	C.	
		Attaching parts for DAS,185/06, Clip :—									
28D/12513	A25/2C	Bolt, 2 BA ... ..						1	—	C.	
28M/10298	AGS.2001/C/2	Nut, 2 BA ... ..						1	—	C.	
28W/12665	SP.14/C	Washer ... ..						1	—	C.	
26FN/2193	DUNLOP DAS.151/16	<b>CLIP</b> , tubular, at tank No. 1, Port only and at inner and outer ends of leading edge						3	—	C.	
		Attaching parts for DAS.151/16, Clip :—									
28D/12512	A25/1C	Bolt, 2 BA ... ..						3	—	C.	
28M/10288	AGS.2001/C/1	Nut, 2 BA ... ..						3	—	C.	
	12 W 2797	<b>CLIP</b> , tubular feed pipe to tank No. 1 at rib No. 3, 18 SWG. L.72						1	—		HB.1
		Attaching parts for 12 W 2797, Clip :—									
28D/12512	A25/1C	Bolt, 2 BA ... ..						1	—	C.	
28M/10288	AGS.2001/C/1	Nut, 2 BA ... ..						1	—	C.	
28W/12252	SP.13/C	Washer ... ..						1	—	C.	
2902	CHENEY CWC9/Mk. 00	<b>CLIP</b> , pipe ... ..						4	—	C.	
2903	CWC9/Mk. 0	<b>CLIP</b> , pipe ... ..						8	—	C.	
2904	CWC9/Mk. 1	<b>CLIP</b> , pipe ... ..						46	—	C.	
2905	CWC9/Mk. 2	<b>CLIP</b> , pipe ... ..						3	—	C.	
2906	CWC9/Mk. 3	<b>CLIP</b> , pipe ... ..						2	—	C.	
2907	CWC9/Mk. 4	<b>CLIP</b> , pipe ... ..						2	—	C.	
27F/2429	SAUNDERS T.20406	<b>COCK</b> , fuel, 4 way, 3/4" BSP, (Pylon tank), Port and Starboard						2	—		HB.1

PIPES AND FITTINGS IN WING

Ref. No.	Part No.	Nomenclature						No. Off	M.R.	Cl. of St.	Plate No.
		1	2	3	4	5	6				
2823	12 P 1006	<b>CONNECTION</b> , feed, forward at rib No. 1 ...						2	—	C.	HB.1
28D/12532	A25/4C	Attaching parts for 12 P 1006, Connection :—									
28M/10288	AGS.2001/C/1	Bolt, 2 BA ... ..						4	—	C.	
		Nut, 2 BA ... ..						4	—	C.	
2824	12 P 1007	<b>CONNECTION</b> , feed, rear, at rib No. 1, Port ...						1	—	C.	HB.1
2825	12 P 1008	<b>CONNECTION</b> , feed, rear, at rib No. 1, Starboard ...						1	—	C.	HB.1
		Attaching parts for 12 P 1007 and 12 P 1008, Connections:									
28D/12531	A25/3C	Bolt, 2 BA ... ..						2	—	C.	
28D/12533	A25/5C	Bolt, 2 BA ... ..						2	—	C.	
628	12 P 49	Packing, half ... ..						2	—	C.	
6022	12 S 1393A	<b>CONNECTION</b> , vent, at rib No. 1, Port ...						1	—	C.	HB.1
6023	12 S 1394A	<b>CONNECTION</b> , vent, at rib No. 1, Starboard ...						1	—	C.	HB.1
5K/3373	AS.3360/B5B AS.3360/B8B	<b>CONNECTORS</b> , bonding, 5-0" long ... ..						24	—	C.	
		<b>CONNECTORS</b> , bonding, 7-5" long ... ..						6	—	—	
		Attaching parts for AS.3360/B5B and AS.3360/B8B, Connectors, bonding :—									
28D/11937	AS.1246/1B	Bolt, 4 BA ... ..						15	—	C.	
28D/8337	AS.1248/1B	Bolt, 4 BA ... ..						1	—	C.	
	DHS.31/28	Clips, tubular, bonding, .5" dia. ... ..						4	—	—	
	DHS.31/31	Clips, tubular, bonding, .75" dia. ... ..						16	—	—	
	DHS.31/32	Clips, tubular, bonding .88" dia. ... ..						1	—	—	
	DHS.31/33	Clips, tubular, bonding 1-0" dia. ... ..						13	—	—	
	DHS.31/44	Clips, tubular, bonding 2-8" dia. ... ..						1	—	—	
	DHS.31/50	Clips, tubular, bonding 2-0" dia. ... ..						1	—	—	
28M/13086	A27/BP	Nut, 4 BA ... ..						7	—	C.	
28M/10287	AGS.2001/B/1	Nut, 4 BA ... ..						17	—	C.	
28S/2761	A31/B12	Screw, 4 BA ... ..						22	—	C.	
28S/2767	A31/B16	Screw, 4 BA ... ..						5	—	C.	
28W/3097	AGS.163/B	Washer ... ..						27	—	C.	
28VV/12305	SP.13/B	Washer ... ..						17	—	C.	
1776	12 P 467A	<b>CONNECTOR</b> , fuel pipe at manifold in wing tip						4	—	C.	HB.3
	12 P 441	<b>CONNECTOR</b> ... ..						4	—	C.	HB.3
1775	12 P 449	<b>SEAL</b> , rubber ... ..						4	—	C.	HB.3
		<b>CORD</b> , retaining tank unit connector, $\frac{3}{32}$ " dia. 3" centres (bind ends with waxed thread)						QR	—	—	
		Attaching parts for retaining cord :—									
9311	12 PT 1435	Washer ... ..						1	—	C.	HB.2
28S/2815	A33/B16	Screw, 4 BA ... ..						1	—	C.	
	DHS.160/B/20	<b>COUPLING</b> , pipe .5" i/d x 2-0" long ... ..						1	—	C.	
	DHS.160/D/20	<b>COUPLING</b> , pipe .75" i/d x 2-0" long ... ..						11	—	C.	
	DHS.160/D/25	<b>COUPLING</b> , pipe .75" i/d x 2-5" long ... ..						1	—	C.	
	DHS.160/F/25	<b>COUPLING</b> , pipe 1" i/d x 1 $\frac{3}{8}$ " long... ..						1	—	C.	
	DHS.160/F/30	<b>COUPLING</b> , pipe 1-0" i/d x 3-0" long ... ..						7	—	C.	
	DHS.160/D/35	<b>COUPLING</b> , pipe .75" i/d x 3-5" long ... ..						1	—	C.	
	12 P 463ND	<b>COUPLING</b> , pipe .375" x 6-5" long ... ..						1	—	—	
		(Make from Dunlop N.1027/6 Section Ref. No. 26DV/5925)									
467	12 P 25	<b>ELBOW</b> , rubber, between vent pipe along leading edge and pipe outboard of tank No. 4						1	—	C.	HB.1

## FUEL SYSTEM

## PIPES AND FITTINGS IN WING

Ref. No.	Part No.	Nomenclature						No. Off	M.R.	Cl. of St.	Plate No.
		1	2	3	4	5	6				
962	12 S 611A/ND	<b>ELBOW</b> , vent pressure at rib No. 1 in Starboard wing						1	—	C.	HB.3
28D/12512	A25/1C	Attaching parts for 12 S 611A/ND, Elbow :—									
28M/10288	AGS.2001/C/1	Bolt, 2 BA	...	...	...	...	2	—	C.		
28W/12252	SP.13/C	Nut, 2 BA	...	...	...	...	2	—	C.		
		Washer	...	...	...	...	2	—	C.		
5998	12 S 1525A	<b>ELBOW</b> , vent, between Ribs No. 11 and No. 12, Port						1	—	C.	
5999	12 S 1526A	<b>ELBOW</b> , vent, between Ribs No. 11 and No. 12, Starboard						1	—	C.	HB.1
	12 P 141	<b>FAIRLEAD</b> , centre for air pressure and transfer pipes at Rib No. 1, 1/4" thick, LFS 21						1	—	—	HB.2
	12 P 143	<b>FAIRLEAD</b> , lower for air pressure and transfer pipes at Rib No. 1, 1/4" thick, LFS 21						1	—	—	HB.2
	12 P 139	<b>FAIRLEAD</b> , upper for air pressure and transfer pipes at Rib, No. 1 1/4" thick, LFS 21						1	—	—	HB.2
		Attaching parts for 12 P 141, 12 P 143, 12 P 139, Fairleads :—									
28D/12531	A25/3C	Bolt, 2 BA	...	...	...	...	1	—	C.		
3231	12-20PT 23	<b>GASKET</b> ... ..						1	—	C.	HB.2
5X/2781	Z.11809	<b>GROMMET</b> , at tank unit fuel contests gauge support ring for cable, tanks No. 1 and No. 3 (Breeze)						2	—	C.	HB.2
—	—	<b>HOSE</b> , joint connections (see Couplings, pipe) ...						—	—	—	
	12 P 1057	<b>LEVER</b> , splined, for 4 way Saunders fuel cock ...						1	—	—	HB.1
		Attaching parts for 12 P 1057, Lever :—									
28D/8507	AS.1242/5C	Bolt, 2 BA	...	...	...	...	1	—	C.		
5473	12 PT 1679A	<b>NECK</b> , filler for tank No. 1 ... ..						1	—	C.	HB.2
		Attaching parts for 12 PT 1679A, Neck :—									
29M/10287	AGS.2001/B/1	Nut, 4 BA	...	...	...	...	12	—	C.		
3889	12 PT 1033A	<b>NECK</b> , filler for tank No. 4 ... ..						1	—	C.	HB.2
		Attaching parts for 12 PT 1033A, Neck :—									
28M/10287	AGS.2001/B/1	Nut, 4 BA	...	...	...	...	12	—	C.		
5926	12 P 683A/ND	<b>PIPE</b> , adaptor, from Teddington valve to hose ...						1	—	C.	HB.3
636	12 P 83/ND	<b>PIPE</b> , air pressure from joint alongside tank No. 1 to joint at rear of undercarriage diaphragm, Port						1	—	C.	HB.1
637	12 P 84/ND	<b>PIPE</b> , air pressure from joint alongside tank No. 1 to joint at rear of undercarriage diaphragm, Starboard						1	—	C.	HB.1
638	12 P 85/ND	<b>PIPE</b> , air pressure from joint at rear of undercarriage diaphragm to hose connection, Port						1	—	C.	HB.1
639	12 P 86/ND	<b>PIPE</b> , air pressure from joint at rear of undercarriage diaphragm to hose connection Starboard						1	—	C.	HB.1
640	12 P 119/ND	<b>PIPE</b> , air pressure from Rib No. 1 to joint alongside tank No. 1, Port						1	—	C.	HB.1
641	12 P 120/ND	<b>PIPE</b> , air pressure from Rib No. 1 to joint alongside tank No. 1, Starboard						1	—	C.	HB.1
5927	12 P 813A/ND	<b>PIPE</b> , air pressure between pressure intake pipe and pressure reducing valves, Port						1	—	C.	HB.3
5928	12 P 814/AND	<b>PIPE</b> , air pressure, between pressure intake pipe and pressure reducing valves, Starboard						1	—	C.	HB.3
621	12 P 5	<b>PIPE</b> , feed from tank No. 2 to tank No. 1, Port ...						1	—	C.	HB.1

PIPES AND FITTINGS IN WING

Ref. No.	Part No.	Nomenclature						No. Off	M.R.	Cl. of St.	Plate No.
		1	2	3	4	5	6				
622	12 P 6	PIPE, feed from tank No. 2 to tank No. 1, Starboard						1	—	C.	HB.1
623	12 P 7A	PIPE, feed from tank No. 3 to tank No. 2 ... ..						1	—	C.	HB.1
624	12 P 9A	PIPE, feed from tank No. 4 to tank No. 3, Port ...						1	—	C.	HB.1
625	12 P 10A	PIPE, feed from tank No. 4 to tank No. 3, Starboard						1	—	C.	HB.1
631	12 P 75/ND	PIPE, feed between 1st and 2nd joints at rear of undercarriage diaphragm						1	—	C.	HB.1
632	12 P 77/ND	PIPE, feed from joint at rear of undercarriage diaphragm, to tank No. 3						1	—	C.	
1577	12 P 619/ND	PIPE, feed from tank No. 1 to 1st joint rear of undercarriage diaphragm						1	—	C.	HB.1
5929	12 P 815A/ND	PIPE, fuel pressure transfer between reducing valve and Teddington valve, Port						1	—	C.	HB.3
5930	12 P 816A/ND	PIPE, fuel pressure transfer between reducing valve and Teddington valve, Starboard						1	—	C.	HB.3
5931	12 P 955/ND	PIPE, fuel pressure transfer from manifold to pipe to fuselage tank, Port						1	—	C.	HB.3
5932	12 P 956A/ND	PIPE, fuel pressure transfer from manifold to pipe to fuselage tank, Starboard						1	—	C.	HB.3
5917	12 P 363A/ND	PIPE, fuel pressure transfer between non-return valve and manifold and hose to Teddington valve, Port						1	—	C.	HB.3
5918	12 P 364A/ND	PIPE, fuel pressure transfer between non-return valve and manifold and hose to Teddington valve, Starboard						1	—	C.	HB.3
5933	12 P 957/ND	PIPE, fuel pressure transfer between non-return valve and pipe from Pylon tank, Port						1	—	C.	HB.3
5934	12 P 958/ND	PIPE, fuel pressure transfer between non-return valve and pipe from Pylon tank, Starboard						1	—	C.	HB.3
5916	12 P 355A/ND	PIPE, fuel pressure transfer from hose connection on fuel pipe to Pylon tank to non-return valve						1	—	C.	
5941	12 P 1011A/ND	PIPE, fuel transfer between reducing valve and non-return valve, Port						1	—	C.	HB.3
5942	12 P 1012A/ND	PIPE, fuel transfer between reducing valve and non-return valve, Starboard						1	—	C.	HB.3
1570	12 P 663/ND	PIPE, fuel transfer between wing tip installation and 4 way cock installation						1	—	C.	HB.1
1571	12 P 665/ND	PIPE, fuel transfer between wing tip installation and 4 way cock installation						1	—	C.	HB.1
5923	12 P 437A/ND	PIPE, fuel transfer between 4 way cock and fuel transfer pipe to wing tip tank, Port						1	—	C.	HB.1
5924	12 P 438A/ND	PIPE, fuel transfer between 4 way cock and fuel transfer pipe to wing tip tank, Starboard						1	—	C.	HB.1
5921	12 P 433A/ND	PIPE, fuel transfer between 4 way cock and fuel transfer pipe to wing tip tank, Port						1	—	C.	HB.1
5922	12 P 434A/ND	PIPE, fuel transfer between 4 way cock and fuel transfer pipe to wing tip tank, Starboard						1	—	C.	HB.1
5935	12 P 979A/ND	PIPE, fuel transfer between pipe in Pylon and 4 way cock, upper, Port						1	—	C.	HB.1
5936	12 P 980A/ND	PIPE, fuel transfer between pipe in Pylon and 4 way cock, upper, Starboard						1	—	C.	HB.1
5919	12 P 423A/ND	PIPE, fuel transfer, between pipe in Pylon and 4 way cock, lower, Port						1	—	C.	HB.1
5920	12 P 424A/ND	PIPE, fuel transfer between pipe in Pylon and 4 way cock, lower, Starboard						1	—	C.	HB.1

FUEL SYSTEM

PIPES AND FITTINGS IN WINGS

Ref. No.	Part No.	Nomenclature						No. Off	M.R.	Cl. of St.	Plate No.
		1	2	3	4	5	6				
635	12 P 81/ND	PIPE,	fuel transfer from joint at rear of undercarriage diaphragm to hose connection					1	—	C.	HB.1
642	12 P 121/ND	PIPE,	fuel transfer from Rib No. 1 to joint alongside tank No. 1, Port					1	—	C.	HB.1
643	12 P 122/ND	PIPE,	fuel transfer from Rib No. 1 to joint alongside tank No. 1, Starboard					1	—	C.	HB.1
1562	12 P 487A/ND	PIPE,	fuel transfer from joint alongside tank No. 1 to non-return valve rear of undercarriage diaphragm, Port					1	—	C.	HB.1
1563	12 P 488A/ND	PIPE,	fuel transfer from joint alongside Tank No. 1 to non-return valve rear of undercarriage diaphragm, Starboard					1	—	C.	
1564	12 P 491A/ND	PIPE,	fuel transfer from non-return valve rear of undercarriage diaphragm to joint, Port					1	—	C.	HB.1
1565	12 P 492A/ND	PIPE,	fuel transfer from non-return valve rear of undercarriage diaphragm to joint, Starboard					1	—	C.	HB.1
1566	12 P 659A/ND	PIPE,	fuel transfer, top, Port ... ..					1	—	C.	HB.1
1567	12 P 660/ND	PIPE,	fuel transfer, top, Starboard ... ..					1	—	C.	HB.1
1568	12 P 661/ND	PIPE,	fuel transfer, bottom, Port ... ..					1	—	C.	HB.1
1569	12 P 662/ND	PIPE,	fuel transfer, bottom, Starboard ... ..					1	—	C.	HB.1
—	12 P 457/ND	PIPE,	hose 0.75" x 4.5", No. 1027/12 Dunlop (Make from Section reference No. 26DV/906)					1	—	—	
—	12 P 977/ND	PIPE,	hose 0.75" x 11' 0", N.1027/12 Dunlop (Make from Section reference No. 26DV/906)					1	—	—	HB.1
—	12 P 299/ND	PIPE,	hose 0.5" x 11' 0", N.1027/8 Dunlop (Make from Section reference No. 26DV/905)					1	—	—	HB.1
647	12 S 27A	PIPE,	vent from tank No. 3 to tank No. 4, Port ...					1	—	C.	HB.1
658	12 S 28A	PIPE,	vent from tank No. 3 to tank No. 4, Starboard					1	—	C.	HB.1
649	12 S 121	PIPE,	vent between leading edge pipe and elbow pipe to tank No. 4, Port					1	—	C.	
650	12 S 122	PIPE,	vent between leading edge pipe and elbow pipe to tank No. 4, Starboard					1	—	C.	
653	12 S 135/ND	PIPE,	vent from tank No. 2 to adaptor at Rib No. 6					1	—	C.	HB.1
654	12 S 137A/ND	PIPE,	vent from adaptor at Rib No. 6 to tank No. 3					1	—	C.	HB.1
659	12 S 333/ND	PIPE,	vent from joint at main spar to joint in leading edge, Starboard					1	—	C.	HB.1
661	12 S 369/ND	PIPE,	vent pressure from air duct to elbow at Rib No. 1 in wing, Starboard					1	—	C.	
958	12 S 631/ND	PIPE,	vent from joint at manifold to joint in leading edge, Port					1	—	C.	HB.1
6642	12 S 1455A/ND	PIPE,	vent, at 1st joint, Rib No. 1, Port ... ..					1	—	C.	HB.1
6645	12 S 1473A/ND	PIPE,	vent, at 1st joint, Rib No. 1, Starboard ... ..					1	—	C.	HB.1
614	12 PT 455	PLATE,	cover, access hole, inboard tank No. 2 ...					1	—	C.	HB.2
28D/8306	AS.1242/1C		Attaching parts for 12 PT 455, Plate :— Bolt, 2 BA ... ..					20	—	C.	
613	12 PT 453	PLATE,	cover, access hole, outboard tank No. 2 ...					1	—	C.	HB.2
28D/8306	AS.1242/1C		Attaching parts for 12 PT 453, Plate :— Bolt, 2 BA ... ..					16	—	C.	
604	12 PT 425	PLATE,	cover access hole, tank No. 4 ... ..					1	—	C.	HB.2
28D/8306	AS.1242/1C		Attaching parts for 12 PT 425, Plate :— Bolt, 2 BA ... ..					12	—	C.	
1953	12 PT 1395	PLATE,	cover, at tank unit fuel contents gauge, tank No. 1					1	—	C.	HB.2
28D/8306	AS.1242/1C		Attaching parts for 12 PT 1395, Plate :— Bolt, 2 BA ... ..					16	—	C.	

PIPES AND FITTINGS IN WINGS

Ref. No.	Part No.	Nomenclature						No Off	M.R.	Cl. of St.	Plate No.
		1	2	3	4	5	6				
7167	AM.1933P (Iss. 3)	<b>TANK</b> , No. 3, Port (Mod. Ven. 95) (Mod. Ven. 983)						1	—	A.	HB.2
6550	AM.1933S (Iss. 3)	<b>TANK</b> , No. 3, Starboard (Mod. Ven 95)(Mod. Ven. 983)						1	—	A.	HB.2
7245	FTH.7273 (Iss. 2)	<b>TANK</b> , No. 3, Port (Mod. Ven. 95) (Mod. Ven. 983)						1	—	A.	HB.2
8176	FTH.7274 (Iss. 2)	<b>TANK</b> , No. 3, Starboard (Mod. Ven. 95) (Mod. Ven. 983)						1	—	A.	HB.2
6552	AM.1934P (Iss. 3)	<b>TANK</b> , No. 4, Port (Mod. Ven. 983) ... ..						1	—	A.	HB.2
6553	AM.1934S (Iss. 3)	<b>TANK</b> , No. 4, Starboard (Mod. Ven. 983) ... ..						1	—	A.	HB.2
8187	FTH.7275 (Iss. 2)	<b>TANK</b> , No. 4, Port (Mod. Ven. 983) ... ..						1	—	A.	HB.3
8177	FTH.7276 (Iss.2)	<b>TANK</b> , No. 4, Starboard (Mod. Ven. 983) ... ..						1	—	A.	HB.2
<b>Note</b> :—For loose items for fitting of fuel tanks to spares wing—See Wing Section.											
6A/2926	SIMMONDS GP/352/062	<b>TANK UNIT</b> , fuel contents gauge, tank No. 1, Pacitor						1	—	A.	HB.2
28M/10328	AGS.2002/C/1	Attaching parts for GP/352/062, tank unit :—									
28W/12296	SP.15/C	Nut, 2 BA ... ..						12	—	C.	
609	12 PT 439	Washer ... ..						12	—	C.	
		Washer, jointing ... ..						1	—	C.	
6A/2927	SIMMONDS GP/352/063	<b>TANK UNIT</b> , fuel contents gauge, tank No. 3, Pacitor						1	—	A.	HB.2
28D/12513	A25/2C	Attaching parts for GP/352/063, Tank Unit :—									
28W/12296	SP.15/C	Bolt, 2 BA ... ..						12	—	C.	
609	12 PT 439	Washer ... ..						12	—	C.	
		Washer, jointing ... ..						1	—	C.	HB.2
28F/8213	AGS.1103/B	<b>UNION</b> , body for pressure reducing valve ... ..						4	—	C.	
5946	SPE/P.22A	<b>VALVE</b> , non-return in fuel line from Pylon to wing tip manifold (self priming pump switch)						1	—	A.	HB.3
27F/2401	Flight Refuelling A.9809000/1	<b>VALVE</b> , non-return ... ..						1	—	A.	HB.3
27V/3462	Teddington FAW/A/228	<b>VALVE</b> , non-return, oil dilution type ... ..						1	—	B.	HB.3
27VB/4360	PS.29/8	<b>VALVE</b> , pressure reducing, 5-75 p.s.i. ... ..						2	—	A.	HB.3
28M/10287	AGS.2001/B/1	Attaching parts for PS.29/8, Valve :—									
28N/253	AGS.191/A	Nut, 4 BA ... ..						2	—	C.	
		Washer ... ..						4	—	C.	
—	12 P 495A/ND	<b>VALVE</b> , non-return, with pressure warning switch, at rear of undercarriage diaphragm						1	—	—	HB.1
27F/2155	SPE.1704	<b>VALVE</b> , non-return ... ..						1	—	A.	HB.1
1561	12 P 485	Body, 3 way ... ..						1	—	C.	HB.1
28F/9653	AGS.1138/F	Washer, jointing ... ..						1	—	C.	
—	—	<b>VALVES</b> , anti-surge (See Tanks) ... ..						—	—	—	
28F/10146	AGS.1139/B	<b>WASHER</b> , for pressure reducing valve ... ..						4	—	C.	

JETTISONABLE WING TIP TANK FUEL INSTALLATION

Ref. No.	Part No.	Nomenclature						No. Off	M,R.	Cl. of St.	Plate No.
		1	2	3	4	5	6				
	—	<b>TANK, FUEL, JETTISONABLE WING TIP, 75 GALLON INSTALLATION, PORT (12 W 1061)</b>						1	—	—	HC.1
	—	<b>TANK, FUEL, JETTISONABLE WING TIP, 75 GALLON INSTALLATION, STARBOARD (12 W 1062)</b>						1	—	—	HC.1
875	12 PT 911A	<b>DOOR, access, in fairing, bottom, Port</b> ... ..						1	—	C.	HC.1
876	12 PT 912A	<b>DOOR, access, in fairing, bottom, Starboard...</b> ... ..						1	—	C.	HC.1
873	12 PT 909A	<b>DOOR, access, in fairing, top, Port</b> ... ..						1	—	C.	HC.1
874	12 PT 910A	<b>DOOR, access, in fairing, top, Starboard</b> ... ..						1	—	C.	HC.1
		Attaching parts for 12 PT 911A, 12 PT 912A, 12 PT 909A and 12 PT 910A, Doors :—									
28S/2814	A33/C.16	Screw, 2 BA ... ..						2	—	C.	
5L/X.952431	†	<b>FILAMENT, 28 volt, 24 watt, clear</b> ... ..						1	—	B.	HC.1
5CX/492	†	<b>LAMP, navigation, type A, Port</b> ... ..						1	—	A.	HC.1
5CX/496	†	<b>LAMP, navigation, type A, Starboard</b> ... ..						1	—	A.	HC.1
5CX/494	†	<b>CAP, for glass</b> ... ..						1	—	B.	HC.1
5CX/497	†	<b>GLASS, green, for Starboard lamp</b> ... ..						1	—	B.	HC.1
5CX/493	†	<b>GLASS, red, for Port lamp</b> ... ..						1	—	B.	HC.1
5CX/1955	†	<b>RING, securing</b> ... ..						1	—	C.	HC.1
5CX/490	†	<b>WASHER, jointing</b> ... ..						1	—	C.	HC.1
		Attaching parts for Air Ministry Ref. Nos. 5CX/492 and 5CX/496, Lamps :—									
28M/10286	AGS.2001/A/1	Nut, 6 BA ... ..						4	—	C.	
28W/12429	SP.10/A	Washer ... ..						4	—	C.	
6010	12 PT 1705A/ND	<b>TANK, fuel, jettisonable, wing tip, complete with attachment bolt, Port (Pre Mod. Ven. 920)</b>						1	MR	A.	HC.1
6011	12 PT 1706A/ND	<b>TANK, fuel, jettisonable, wing tip, complete with attachment bolt, Starboard (Pre Mod. Ven. 902)</b>						1	MR	A.	HC.1
10360	12 PT 1815A/ND	<b>TANK, fuel, jettisonable, wing tip, complete with attachment bolt, Port (Pre Mod. Ven. 902)</b>						1	MR	A.	HC.1
10362	12 PT 1816A/ND	<b>TANK, fuel, jettisonable, wing tip, complete with attachment bolt, Starboard (Mod. Ven. 902)</b>						1	MR	A.	HC.1
1779	12 PT 467A	<b>BOLT, suspension (Pre Mod. Ven. 902)</b> ... ..						1	—	C.	
10359	12 PT 467A/1	<b>BOLT, suspension (Mod. Ven. 902)...</b> ... ..						1	—	C.	HC.1
28M/10294	AGS.2001/N/1	<b>NUT, 1/2" BSF</b> ... ..						1	—	C.	
28W/3094	AGS.163/H	<b>WASHER, double spring</b> ... ..						1	—	C.	
10358	12 PT 1813	<b>WASHER, special (Mod. Ven. 902)...</b> ... ..						1	—	C.	
28W/12257	SP.13/N	<b>WASHER, (Pre Mod. Ven. 902)</b> ... ..						1	—	C.	
	12 PT 1703A/ND	<b>TANK, fuel, jettisonable, Port (See Separate Unit) ...</b>						1	MR	—	HC.1
	12 PT 1704A/ND	<b>TANK, fuel, jettisonable, Starboard (See Separate Unit)</b>						1	MR	—	HC.1

JETTISONABLE WING TIP FUEL TANK

Ref. No.	Part No.	Nomenclature						No Off	M.R.	Cl. of St.	Plate No.
		1	2	3	4	5	6				
—	12 PT 1703A/ND	<b>TANK, FUEL, JETTISONABLE, WING TIP, 75 GALLON, PORT</b>						1	MR	—	HD.1
—	12 PT 1704A/ND	<b>TANK, FUEL, JETTISONABLE, WING TIP, 75 GALLON, STARBOARD</b>						1	MR	—	HD.1
4094	12 PT 473	<b>BOLT, steady</b> ... ..						1	—	C.	HD.1
—	12 N 697A	<b>CABLE, earthing, for navigation lamp...</b> ... ..						1	—	—	HD.1
5E/3038	†	<b>CABLE, Unipren, 6 amp.</b> ... ..						QR	—	C.	
5K/	†	<b>CABLE-END, Ross Courtney</b> ... ..						1	—	C.	
5K/107065	No. 1	<b>SLEEVE, binding</b> ... ..						2	—	C.	
—	12 N 695A	<b>CABLE, from navigation lamp to plunger</b> ... ..						1	—	—	HD.1
5E/3038	†	<b>CABLE, Unipren, 6 amp.</b> ... ..						QR	—	C.	
5K/107065	No. 1	<b>SLEEVE, binding</b> ... ..						2	—	C.	
28L/13410	A.27/NT	<b>LOCKNUT, 1/2" BSF, for steady bolt</b> ... ..						1	—	C.	
1741	12 PT 481A	<b>PLUNGER, navigation lamp contact</b> ... ..						1	—	C.	HD.1
	12 PT 485	<b>CUP, for spring</b> ... ..						1	MR	—	HD.1
	12 PT 483	<b>PLATE, cover</b> ... ..						1	MR	—	HD.1
	12 PT 487	<b>PLUNGER</b> ... ..						1	—	—	HD.1
	DHS.19 Mk. 14	<b>SPRING, compression...</b> ... ..						1	—	—	
		Attaching parts for 12 PT 481A, Plunger :—									
28D/8372	AS.1243/2B	Bolt, 4 BA ... ..						4	—	C.	
—	12 PT 159A/4	<b>TANK, fuel, jettisonable, Port</b> ... ..						1	MR	—	HD.1
—	12 PT 160A/4	<b>TANK, fuel, jettisonable, Starboard</b> ... ..						1	MR	—	HD.1
1795	12 PT 701	<b>CAP, filler</b> ... ..						2	—	C.	HD.1
2927	12 PT 1665A	<b>CAP, nose, for navigation lamps</b> ... ..						1	—	C.	HD.1
		Attaching parts for 12 PT 1665A, Cap :—									
28D/8306	AS.1242/1C	Bolt, 2 BA ... ..						12	—	C.	
28N/12611	AGS.2030/24	<b>CIRCLIP, internal, for retaining spring in bonding socket</b>						2	—	C.	
9394	12 PT 1687A	<b>CONE, rear</b> ... ..						1	—	C.	
		Attaching parts for 12 PT 1687A, Cone :—									
28D/8307	AS.1242/2C	Bolt, 2 BA ... ..						20	—	C.	
	12 PT 1169	<b>CONNECTION, fuel</b> ... ..						2	—	—	HD.1
		Attaching parts for 12 PT 1169, Connection :—									
28D/12533	A25/5C	Bolt, 2 BA ... ..						4	—	C.	
28M/10288	AGS.2001/C/1	Nut, 2 BA ... ..						4	—	C.	
9368	12 PT 1177	Shim ... ..						1	MR	C.	HD.1
28W/12296	SP.15/C	Washer ... ..						4	—	C.	
8494	12 PT 1163	Washer, sealing ... ..						1	MR	C.	HD.1
	12 PT 1171	<b>CONNECTION, fuel</b> ... ..						2	—	—	HD.1
		Attaching parts for 12 PT 1171, Connection :—									
28D/12533	A25/5C	Bolt, 2 BA ... ..						3	—	C.	
28M/10288	AGS.2001/C/1	Nut, 2 BA ... ..						3	—	C.	
4103	12 PT 1175	Shim ... ..						1	MR	C.	HD.1
28W/12296	SP.15/C	Washer ... ..						3	—	C.	
	12 PT 1165	Washer, sealing ... ..						1	—	—	HD.1
	12 PT 893	<b>DOOR, inspection</b> ... ..						3	—	—	HD.1
		Attaching parts for 12 PT 893, Door :—									
28D/8309	AS.1242/4C	Bolt, 2 BA ... ..						12	—	C.	

## FUEL SYSTEM

## JETTISONABLE WING TIP FUEL TANK

Ref. No.	Part No.	Nomenclature						No. Off	M.R.	Cl. of St.	Plate No.
		1	2	3	4	5	6				
1011	12 PT 974A/ND	<b>DOOR</b> , inspection, in tank fairing, bottom Port and Starboard top						1	—	C.	HD.1
1010	12 PT 973A/ND	<b>DOOR</b> , inspection, in tank fairing, bottom Starboard and Port top						1	—	C.	HD.1
28S/2862	A32/C.16	Attaching parts for 12 PT 974A/ND and 12 PT 973A/ND, Doors :—						3	—	C.	
2344	12 PT 1463A	<b>FILTER</b> , at fuel feed pipe ... ..						1	—	B.	HD.1
28D/8309	AS.1242/4C	Attaching parts for 12 PT 1463A, Filter :—						10	—	C.	
26FC/6525	P.981739	Bolt, 2 BA ... ..						1	—	C.	HD.1
26FC/3816	P.002143	Ring, bearing, for bolt heads ... ..						1	—	C.	HD.1
28M/10332	AGS.2002/J/1	Washer, jointing ... ..						1	—	C.	HD.1
28M/10332	AGS.2002/J/1	<b>NUT</b> , $\frac{3}{16}$ " BSF, for front locating spigot ... ..						1	MR	C.	
		<b>NUT</b> , $\frac{3}{16}$ " BSF, for rear locating spigot ... ..						1	MR	C.	
	12 PT 1151	<b>PLATE</b> , cover, for fuel connections ... ..						1	MR	—	HD.1
28D/12531	A25/3C	Attaching parts for 12 PT 1151, Plate :—						16	MR	C.	
28M/10288	AGS.2001/C/1	Bolt, 2 BA ... ..						16	MR	C.	
28W/12296	SP.15/C	Nut, 2 BA ... ..						16	MR	C.	
—	12 PT 1153	Washer ... ..						1	MR	—	HD.1
781	12 PT 269ND	Washer, sealing ... ..						1	—	C.	HD.1
28D/12531	A25/3C	<b>PLATE</b> , cover, for handhole ... ..						1	—	C.	HD.1
782	12 PT 271	Attaching parts for 12 PT 269ND, Plate :—						12	—	C.	
2926	12-20 PT 511	Bolt, 2 BA ... ..						1	—	C.	HD.1
28D/12515	A25/10C	Nut, 2 BA ... ..						4	—	C.	
28M/10288	AGS.2001/C/1	Washer ... ..						4	—	C.	
28W/12252	SP.13/C	Washer, sealing ... ..						4	—	C.	
787	12 PT 695	<b>PLUG</b> , drain ... ..						2	—	C.	HD.1
26FC/8735	P.002101	<b>PLUNGER</b> , for earthing socket ... ..						2	—	C.	HD.1
789	12 PT 699	<b>RING</b> , adaptor, for filler cap ... ..						2	MR	C.	HD.1
28D/8302	AS.1242/3B	Attaching parts for 12 PT 699, Ring :—						16	MR	C.	
28M/10287	AGS.2001/B/1	Bolt, 4 BA ... ..						16	MR	C.	
28W/12306	SP.15/B	Nut, 4 BA ... ..						16	MR	C.	
26FC/4099	P.002670	Washer ... ..						1	MR	C.	HD.1
26FC/3818	P.002140	Washer, sealing ... ..						2	MR	C.	HD.1
	12 PT 273A	<b>RING</b> , bearing, for nuts or bolts securing adaptor ring for filler cap						1	MR	—	HD.1
28D/8300	AS.1242/1B	Attaching parts for 12 PT 273A, Ring :—						3	MR	C.	
28M/10287	AGS.2001/B/1	Bolt, 4 BA ... ..						3	MR	C.	
26FC/10338	P.002103	Nut, 4 BA ... ..						2	—	C.	HD.1
7805	12 PT 1267ND	<b>RING</b> , retaining, for earthing socket spring 0.94" o/d x 18 SWG, S.84						1	MR	C.	HD.1
		<b>SHIM</b> , for rear locating spigot (Brass 0.05" thick, Comml.)						1	MR	C.	HD.1

FUEL SYSTEM

JETTISONABLE WING TIP FUEL TANK

Ref. No.	Part No.	Nomenclature						No. Off	M.R.	Cl. of St.	Plate No.
		1	2	3	4	5	6				
783	12 PT 293							2	MR	C.	HD.1
26FC/8736	P.002102							2	—	C.	HD.1
788	12 PT 697ND							2	—	C.	HD.1
26BY/5925	H.7680							2	—	C.	
4108	12 PT 891							3	—	C.	
4100	12 PT 1393							1	MR	C.	HD.1
28W/12255	SP.13/J							1	MR	C.	
28W/12321	SP.15/J							1	MR	C.	
	12-20PT 509							1	—	—	HD.1
								Attaching parts for 12-20PT 509, Weight :—			
28D/12532	A25/4C							12	—	C.	
28W/12252	SP.13/C							12	—	C.	

PLASTIC JETTISONABLE WING TIP FUEL TANK

Ref. No.	Part No.	Nomenclature						No. Off	M.R.	Cl. of St.	Plate No.
		1	2	3	4	5	6				
5996	75-02-0001 BRISTOL A/c Co.	<b>TANK</b> , plastic, fuel, jettisonable, wing tip, 75 gallons, Port (Mod. Ven. 1003) (S.O.O.) alternative to Tank 12 PT 159A/4, Port						1	—	A.	
5997	75-02-0002	<b>TANK</b> , plastic, fuel, jettisonable, wing tip, 75 gallons, Starboard (Mod. Ven. 1003) (S.O.O.) alternative to Tank 12 PT 160A/4 Starboard						1	—	A.	
5E/3037	†	<b>CABLE</b> , Unipren 4 ... ..						QR	—	C.	
	75-02-0413	<b>DOOR</b> , inspection, top front, Port ... ..						1	—		
	75-02-0414	<b>DOOR</b> , inspection, top front, Starboard ... ..						1	—		
	75-02-0409	<b>DOOR</b> , inspection, top rear ... ..						1	—		
	75-02-0410	<b>DOOR</b> , inspection, bottom rear ... ..						1	—		
		Attaching parts for 75-02-0413, 75-02-0414, 75-02-0409 and 75-02-0410, Doors :—									
28D/8375	AS.1243/1/C	Bolt, 2 BA ... ..						4	—	C.	
	75-02-0369	<b>DOOR</b> , inspection, bottom front, Port ... ..						1	—		
	75-02-0370	<b>DOOR</b> , inspection, bottom front, Starboard ... ..						1	—		
		Attaching parts for 75-02-0369 and 75-02-0370, Doors :—									
28D/8375	AS.1243/1/C	Bolt, 2 BA ... ..						5	—	C.	
	75-02-0386	<b>FRAME</b> , '114' ... ..						1	MR		
	75-02-0314	<b>FRAME</b> , '30-5' ... ..						1	MR		
	75-02-0013	<b>SHELL</b> , centre, complete with aft shell, tail cone and main fairing, Port						1	—		
	75-02-0014	<b>SHELL</b> , centre, complete with aft shell, tail cone and main fairing, Starboard						1	—		
	75-02-0397	<b>BOLT</b> , adjustment, rear ... ..						1	—		
		Attaching parts for 75-02-0397, Bolt :—									
28M/14344	A58/NT	Nut, 1/2" BSF ... ..						1	—	C.	

FUEL SYSTEM

PLASTIC JETTISONABLE WING TIP FUEL TANK

Ref. No.	Part No.	Nomenclature						No. Off	M.R.	Cl. of St.	Plate No.
		1	2	3	4	5	6				
	75-02-0382										
28M/10294	AGS.2001/N1										
28W/15727	SP.55/N										
28W/12257	SP.13/N										
	75-02-0388										
	75-02-0405										
	75-02-0305										
28N/12611	AGS.2030/24										
28E/8183	AGS.605/1										
	75-02-0334										
	75-02-0387										
	75-02-0329										
28D/12512	A25/1C										
	75-02-0407										
	75-02-0331										
28W/416643	SP.47/C										
	75-02-0328										
28D/12512	A25/1C										
	75-02-0408										
	75-02-0330										
28W/416643	SP.47/C										
	75-02-0329										
28D/12512	A25/1C										
	75-02-0407										
	75-02-0331										
28W/416643	SP.47/C										

PLASTIC JETTISONABLE WING TIP FUEL TANK

Ref. No.	Part No.	Nomenclature						No. Off	M.R.	Cl. of St.	Plate No.
		1	2	3	4	5	6				
	75-02-0325							1	MR		
	75-02-0326							1	MR		
	75-02-0395							1	MR		
	75-02-0396							1	MR		
	75-02-0319							1	MR		
	75-02-0320							1	MR		
	75-02-0327							1	MR		
	75-02-0315							1	MR		
	75-02-0316							1	MR		
	75-02-0313							1	MR		
	75-02-0321							1	MR		
	75-02-0322							1	MR		
		Attaching parts for 75-02-0321 and 75-02-0322, Frames :—									
	75-02-0379							1	—		
	75-02-0380							1	—		
	75-02-0311							1	—		
	DOWTY GD.1240-8D							4	—		
11571	75-02-0306							1	—	C.	
	75-02-0333							1	—		
	75-02-0357							1	—		
	75-02-0351							1	—		
	75-02-0355							1	—		
11587	75-02-0359							1	—	C.	
	75-02-0393							1	—		
	75-02-0360							1	—		
	75-02-0356							1	—		
	75-02-0337							1	MR		
	75-02-0338							1	MR		
	75-02-0339							1	MR		
	75-02-0340							1	MR		
	75-02-0341							1	MR		
	75-02-0342							1	MR		
	75-02-0343							1	MR		
	75-02-0344							1	MR		
	75-02-0345							1	—		
		Attaching parts for 75-02-0345, Pipe :—									
28D/12528	A25/1B							1	—	C.	
5K/114	†							2	—	C.	
28M/10327	AGS.2002/B1							1	—	C.	
5K/200	†							QR	—	C.	
28F/14656	AGS.1186/2							1	—	C.	
28W/12305	SP.13/B							1	—	C.	

FUEL SYSTEM

PLASTIC JETTISONABLE WING TIP FUEL TANK

Ref. No.	Part No.	Nomenclature						No. Off	M.R.	Cl. of St.	Plate No.
		1	2	3	4	5	6				
	75-02-0332							1	MR		
	75-02-0389							1	—		
28D/8375	AS.1243/1C							3	—	C.	
28D/12528	A25/1B							1	—	C.	
28L/11069	AGS.2035/C							3	—	C.	
28W/3097	AGS.162/B							1	—	C.	
	BS.3474/1							1	—	C.	
	75-02-0350							1	—		
	75-02-0390							1	—		
11576	75-02-0398							1	—	C.	
	75-02-0304							1	MR		
	75-02-0349							1	MR		
	BS.05-22							1	—		
11577	75-02-0400							1	—	C.	
	75-02-0361							1	—		
	75-02-0017							1	MR		
	75-02-0375							1	—		
	75-02-0353							1	—		
	75-02-0346							1	—		
	75-02-0347							1	—		
	75-02-0354							1	—		
	75-02-0376							2	MR		
	75-02-0303							1	MR		
	75-02-0352							1	—		
11575	75-02-0374							1	—		
	75-02-0399							1	—	C.	
	75-02-0391							1	—		
	75-02-0358							1	—		
	75-02-0011							1	—		
	75-02-0012							1	—		



FUEL SYSTEM

PLASTIC JETTISONABLE WING TIP FUEL TANK

Ref. No.	Part No.	Nomenclature						No. Off	M.R.	Cl. of St.	Plate No.
		1	2	3	4	5	6				
11572	75-01-0336							1	—	C.	
28D/9798	AS.1248/3E							13	—	C.	
28D/12135	AS.1248/5E							2	—	C.	
28S/7812	PARKER KALON S.970							2	—	C.	
28F/14253	AGS.1186/4							15	—	C.	
	75-02-0303							1	MR		
11575	75-02-0399							1	—	C.	
	75-02-0362							1	—		
	SNU.0537/17/9							6	—	C.	
28S/	PARKER KALON S.980							6	—	C.	

JETTISONABLE UNDERWING FUEL TANK

Ref. No.	Part No.	Nomenclature						No Off	M.R.	Cl. of St.	Plate No.
		1	2	3	4	5	6				
8750	12 PT 871A/3	<b>TANK, FUEL, JETTISONABLE, UNDERWING</b> (Mod. Ven. 659)						1	—	A.	HE.1
		Attaching parts for 12 PT 871A/3, Tank :—									
7200	DOWTY SP.910/14	Ring, sealing "O" ... ..						1	—	C.	
7199	DOWTY SP.910/10	Ring, sealing "O" ... ..						1	—	C.	
7249	75-05-0001 BRISTOL A/C. Co.	<b>TANK, PLASTIC, FUEL JETTISONABLE UNDERWING</b> (Mod. Ven. 707) (S.O.O.) Alternative to 12 PT 871A/3, Tank						1	—	A.	
9245	12 PT 879A/1	<b>BOLT</b> , attachment, centre portion (Mod. Ven. 659)						1	—	C.	HE.1
		Attaching parts for 12 PT 879A/1, Bolt :—									
28M/13227	A24/NS	Nut, 1/2" BSF ... ..						1	—	C.	
28P/12463	SP.9/E10	Pin, split ... ..						1	—	C.	
28V/12257	SP.13/N	Washer ... ..						1	—	C.	
1795	12 PT 701	<b>CAP</b> , filler ... ..						1	—	C.	HE.1
28N/12611	AGS.2030/24	<b>CIRCLIP</b> , internal, for retaining spring in bonding socket						1	—	C.	
7198	12 PT 1743A	<b>CONE</b> , rear and stabiliser ... ..						1	—	C.	HE.1
9394	12 PT 1687A	<b>CONE</b> , rear ... ..						1	—	C.	HE.1
	12 PT 1565A	<b>STABILISER</b> ... ..						2	—		HE.1
		Attaching parts for 12 PT 1565A, Stabiliser :—									
28D/8323	AS.1242/2E	Bolt, 1/2" BSF ... ..						2	—	C.	
28D/8325	AS.1242/4E	Bolt, 1/2" BSF ... ..						18	—	C.	
28M/10290	AGS.2001/E/1	Nut, 1/2" BSF ... ..						8	—	C.	
		Attaching parts for 12 PT 1743A, Cone :—									
28D/8307	AS.1242/2C	Bolt, 2 BA ... ..						20	—	C.	
	12 PT 1509	<b>CONNECTOR</b> , jettisonable fuel tank ... ..						1	—		HE.1
2344	12 PT 1463A	<b>FILTER</b> , fuel pipe centre portion ... ..						1	—	B.	HE.1
		Attaching parts for 12 PT 1463A, Filter :—									
28D/8507	AS.1242/5C	Bolt ... ..						10	—	C.	
26FC/6525	P.981739	Washer, ring... ..						1	—	C.	HE.1
26FC/3816	P.002143	Washer, sealing ... ..						1	—	C.	HE.1
	12 PT 893	<b>PLATE</b> , cover, front and centre portions of tank						4	—		HE.1
		Attaching parts for 12 PT 893, Plate :—									
28D/8309	AS.1242/4C	Bolt, 2 BA ... ..						12	—	C.	
4108	12 PT 891	Washer, sealing ... ..						1	—	C.	
	12 PT 963A/1	<b>PLATE</b> , sole for centre portion (Mod. Ven. 659) ... ..						1	—		HE.1
9247	12 PT 1783	<b>SPIGOT</b> ... ..						1	—	C.	HE.1
9246	12 PT 1785	<b>SPIGOT</b> ... ..						1	—	C.	HE.1
787	12 PT 695	<b>PLUG</b> , drain, front and centre portions of tank ... ..						2	—	C.	HE.1
26FC/8735	P.002101	<b>PLUNGER</b> , for bonding socket... ..						1	—	C.	HE.1
	12 PT 855A/1	<b>PIPE</b> , fuel, centre portion ... ..						1	—		HE.1
789	12 PT 699	<b>RING</b> , adaptor for filler cap ... ..						1	—	C.	HE.1
		Attaching parts for 12 PT 699, Ring :—									
28D/8302	AS.1242/3B	Bolt, 4 BA ... ..						16	—	C.	
28M/10287	AGS.2001/B/1	Nut, 4 BA ... ..						16	—	C.	
28W/12306	SP.15/B	Washer ... ..						6	—	C.	
26FC/4099	P.002670	Washer, sealing ... ..						1	—	C.	HE.1
26FC/3818	P.002140	<b>RING</b> , bearing for filler cap ... ..						1	—	C.	HE.1
	P.002141A	<b>RING</b> , nut on filter ... ..						1	—		HE.1
26FC/10338	P.002103	<b>RING</b> , retaining for bonding socket spring ... ..						1	—	C.	HE.1
788	12 PT 697ND	<b>RING</b> , sealing for front and centre portion drain plugs						2	—	C.	HE.1

FUEL SYSTEM

JETTISONABLE UNDERWING FUEL TANK

Ref. No.	Part No.	Nomenclature						No. Off	M.R.	Cl. of St.	Plate No.
		1	2	3	4	5	6				
26FC/8736	P.002102	<b>SPRING</b> , for bonding socket ... ..						1	—	C.	HE.1
26BY/5925	H.7680	<b>WASHER</b> , jointing for filler cap ... ..						1	—	C.	HE.1
8757	12 PT 1757	<b>WASHER</b> , sealing for connector and fuel pipe in centre portion (Mod. Ven. 515)						1	—	C.	
		Attaching parts for 12 PT 1757, Washer :—									
28D/8507	AS.1242/5C	Bolt, 2 BA ... ..						6	—	C.	
28M/10288	AGS.2001/C/1	Nut, 2 BA ... ..						6	—	C.	
28W/12252	SP.13/C	Washer ... ..						6	—	C.	
8758	12 PT 1751A	<b>WASHER</b> , sealing for sole plate on centre portion (Mod. Ven. 515)						1	—	C.	
		Attaching parts for 12 PT 1751, Washer :—									
28D/8507	AS.1242/5C	Bolt, 2 BA ... ..						24	—	C.	
28D/8311	AS.1242/7C	Bolt, 2 BA ... ..						2	—	C.	
28D/8310	AS.1242/6C	Bolt, 2 BA ... ..						10	—	C.	
28M/10288	AGS.2001/C/1	Nut, 2 BA ... ..						36	—	C.	
28W/12252	SP.13/C	Washer ... ..						36	—	C.	
	12 PT 929A	<b>VALVE</b> , anti-surge, Baffle No. 3 and No. 6 ... ..						2	—		HE.1
		Attaching parts for 12 PT 929A, Valve :—									
28D/12512	A25/1C	Bolt, 2 BA ... ..						4	—	C.	

PLASTIC JETTISONABLE UNDERWING FUEL TANK

Ref. No.	Part No.	Nomenclature						No. Off	M.R.	Cl. of St.	Plate No.
		1	2	3	4	5	6				
7249	75-05-0001 BRISTOL A/C Co.	<b>TANK</b> , plastic fuel jettisonable underwing, 77 gallons (Mod. Ven. 707) (S.O.O.) Alternative to tank 12 PT 871A/3						2	—	A.	
11573	75-05-0323A	<b>BRACKET</b> , top, fin attachment ... ..						1	—	C.	
11574	75-05-0323B	<b>BRACKET</b> , bottom, fin attachment ... .. Attaching parts for 75-05-0323A and 75-05-0323B Brackets :—						1	—	C.	
28D/12518	A25/2E	Bolt, 3/4" BSF ... ..						4	—	C.	
28W/416644	SP.47/E	Washer, spring ... ..						4	—	C.	
11565	75-05-0303	<b>CONE</b> , tail ... .. Attaching parts for 75-05-0303 Cone :—						1	—	C.	
28D/8341	AS.1248/1C	Bolt, 2 BA ... ..						6	—	C.	
11566	75-05-0327	Fin ... .. Attaching parts for 75-05-0327 Fin :—						1	—	C.	
28D/12543	A25/6E	Bolt, 1/2" BSF ... ..						4	—	C.	
28M/10330	AGS.2002/E1	Nut, 1/2" BSF ... ..						4	—	C.	
28W/12352	SP.10/E	Washer ... ..						4	—	C.	
11572	75-01-0336	<b>RING</b> , sealing, shells ... .. Attaching parts for 75-01-0336 Ring :—						1	—	C.	
28D/9798	AS.1248/3E	Bolt, 1/2" BSF ... ..						16	—	C.	
28F/14253	AGS.1186/4	Washer, sealing ... ..						16	—	C.	
11567	75-05-001	<b>SHELL</b> , forward group ... .. Consisting of :—						1	—	C.	
11570	75-02-0305	<b>CAP</b> , filler ... ..						1	—	C.	
28N/12611	AGS.2030-24	<b>CIRCLIP</b> ... ..						1	—	C.	
5K/117	AGS.1661/F	<b>CLIP</b> , bonding ... ..						1	—	C.	
11571	75-03-0305	<b>FRAME</b> ... ..						1	MR		
11571	75-02-0306	<b>GASKET</b> , filler, cap ... ..						1	—	C.	
11576	75-02-0398	<b>PLUNGER</b> ... ..						1	—	C.	
11577	75-02-0304	<b>RING</b> , filler ... ..						1	MR		
11577	75-02-0400	<b>RING</b> , retaining, plunger ... ..						1	—	C.	
11575	75-02-0303	<b>SOCKET</b> , bonding ... ..						1	MR		
11575	75-02-0399	<b>SPRING</b> , plunger ... ..						1	—	C.	
28D/12512	A25/1C	<b>STRIP</b> , bonding, filler cap to bonding socket, 7" long Attaching parts for BS.743 Strip :—						1	—	C.	
28M/10328	AGS.2002/C1	Botl, 2 BA ... ..						1	—	C.	
28W/14741	SP.24/C	Nut, 2 BA ... ..						1	—	C.	
		Washer ... ..						1	—	C.	
	75-05-0013	<b>SHELL</b> , main, group ... .. Consisting of :—						1	—		
	75-05-0302	<b>SHELL</b> , aft, group ... .. Consisting of :—						1	MR		
	75-05-0335	<b>FRAME</b> , stiffening ... ..						1	MR		
	75-05-0309	<b>FRAME</b> , No, 8 ... ..						1	MR		
28M/9999	AGS.2012/C11	<b>NUT PLATE</b> (floating anchor) ... ..						6	—		
	BS.743/E	<b>STRIP</b> , bonding, frame 8 to bracket ... .. Attaching parts for BS.743/E Strip :—						1	—	C.	
28D/12513	A.25/2C	Bolt, 2 BA ... ..						1	—	C.	
28M/10288	AGS.2001/C1	Nut, 2 BA ... ..						1	—	C.	
28W/12252	SP.13/C	Washer ... ..						2	—	C.	

FUEL SYSTEM

PLASTIC JETTISONABLE UNDERWING FUEL TANK

Ref. No.	Part No.	Nomenclature						No. Off	M.R.	Cl. of St.	Plate No.
		1	2	3	4	5	6				
	75-05-0012	<b>SHELL</b> , centre, group ... ..						1	MR		
		Consisting of :—									
11578	75-01-0326	<b>ADAPTOR</b> , lug ... ..						1	—	C.	
11585	75-05-0313	<b>CAP</b> , filter ... ..						1	—	C.	
	MARSTON BM.639	<b>DISC</b> , inner, flap, surge valve ... ..						2	MR		
	MARSTON BM.639	<b>DISC</b> , outer, flap, surge valve ... ..						2	MC		
	MARSTON BM.639	<b>FLAP</b> , surge valve ... ..						2	MR		
	75-05-05-0304	<b>FRAME</b> , No. 3 ... ..						1	MR		
	75-05-0305	<b>FRAME</b> , No. 4 ... ..						1	MR		
	75-05-0306	<b>FRAME</b> , No. 5 ... ..						1	MR		
	75-05-0307	<b>FRAME</b> , No. 6 ... ..						1	MR		
	75-01-0320	<b>FITTING</b> , attachment, main frame ... ..						1	MR		
11569	75-01-0319	<b>GASKET</b> , drain plug ... ..						1	—	C.	
11587	75-02-0393	<b>HOUSING</b> , filter ... ..						1	—	C.	
12A/2076	ARM.63909	<b>LUG</b> , suspension ... ..						1	—		
28M/11107	AGS.2012/E11	<b>NUT</b> , plate (Floating Anchor) ... ..						16	—	C.	
11581	75-05-0316	<b>PIPE</b> , fuel, 3/4" o/d ... ..						1	—	C.	
	75-05-0320	<b>PLATE</b> , guard, surge valve ... ..						1	MR		
		Attaching parts for 75-05-0320 Plate :—									
28D/12513	A.25/2C	Bolt, 2 BA ... ..						3	—	C.	
28M/10328	AGS.2002/C/1	Nut, 2 BA ... ..						3	—	C.	
28W/12252	SP.13/C	Washer ... ..						3	—	C.	
11568	75-01-0341	<b>PLUG</b> , drain ... ..						1	—	C.	
	75-05-0330	<b>PLATE</b> , packing ... ..						1	MR		
		Attaching parts for 75-05-0330 Plate :—									
	AS.1242/5C	Bolt, 2 BA ... ..						5	—	C.	
	75-05-0310	<b>RING</b> , drain plug ... ..						1	MR		
	75-05-0312	<b>RING</b> , filter ... ..						1	MR		
11580	75-05-0314	<b>SPIGOT</b> , front ... ..						1	—	C.	
11580	75-05-0314	<b>SPIGOT</b> , rear ... ..						1	—	C.	
	BS.743	<b>STRIP</b> , bonding, jointing ring to frame 8" long						1	—		
		Attaching parts BS.743 Strip :—									
28D/8375	AS.1243/1C	Bolt, 2 BA ... ..						1	MR	C.	
28M/10328	AGS.2002/C/1	Nut, 2 BA ... ..						1	—	C.	
28W/12252	SP.13/C	Washer ... ..						1	—	C.	
11579	75-05-0333	<b>WASHER</b> , sealing, spigot ... ..						1	MR		
	75-01-0324	<b>WASHER</b> , sealing, adapter ... ..						1	—	C.	
	75-01-0362	<b>WASHER</b> , sealing (Alternative to 75-01-0324)						QR	—		
	75-01-0363	<b>WASHER</b> , sealing (Alternative to 75-01-0324)						QR	—		
	75-01-0364	<b>WASHER</b> , sealing (Alternative to 75-01-0324)						QR	—		
11583	75-05-0331	<b>WASHER</b> , sealing, fuel connections ... ..						1	—	C.	
11586	75-05-0317	<b>WASHER</b> , sealing, filter ... ..						1	—	C.	

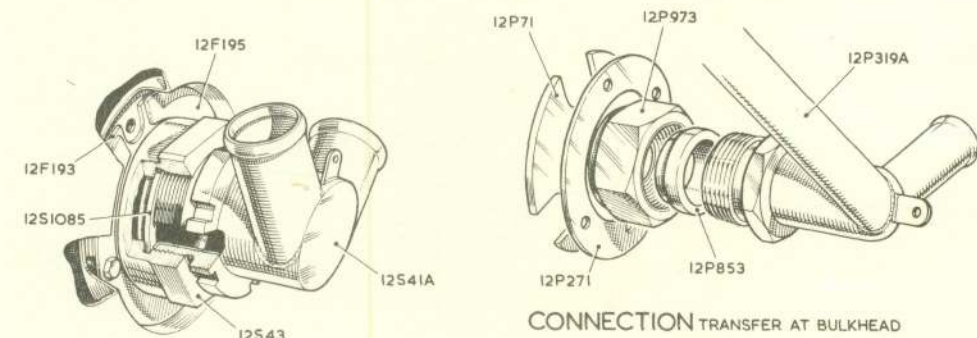

CONNECTION VENT AT BULKHEAD

CONNECTION TRANSFER AT BULKHEAD

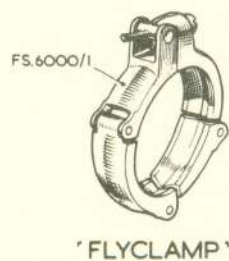
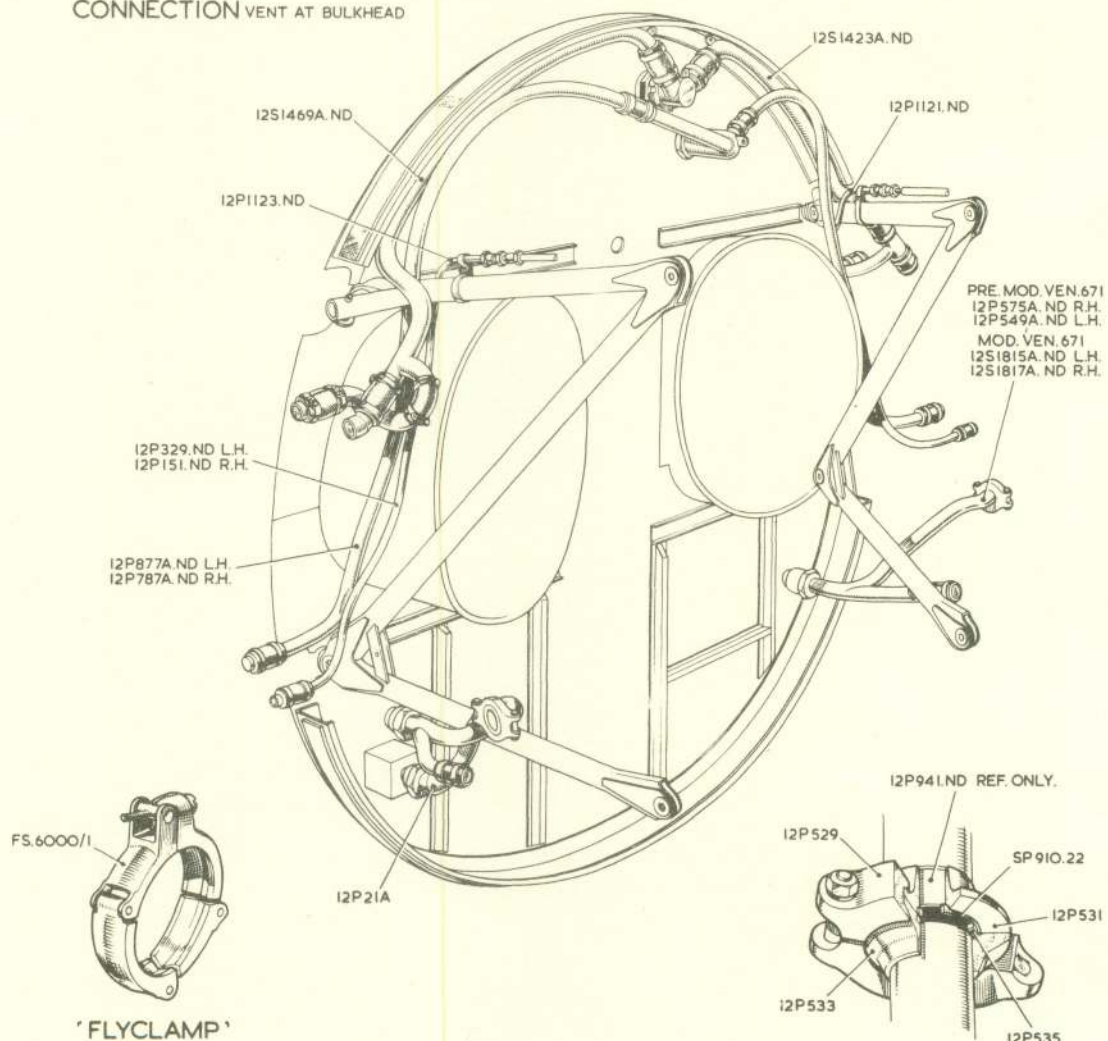

'FLYCLAMP'

H.I.

**FUEL SYSTEM  
PIPES AND FITTINGS IN  
FUSELAGE AND AT ENGINE**

H.I.

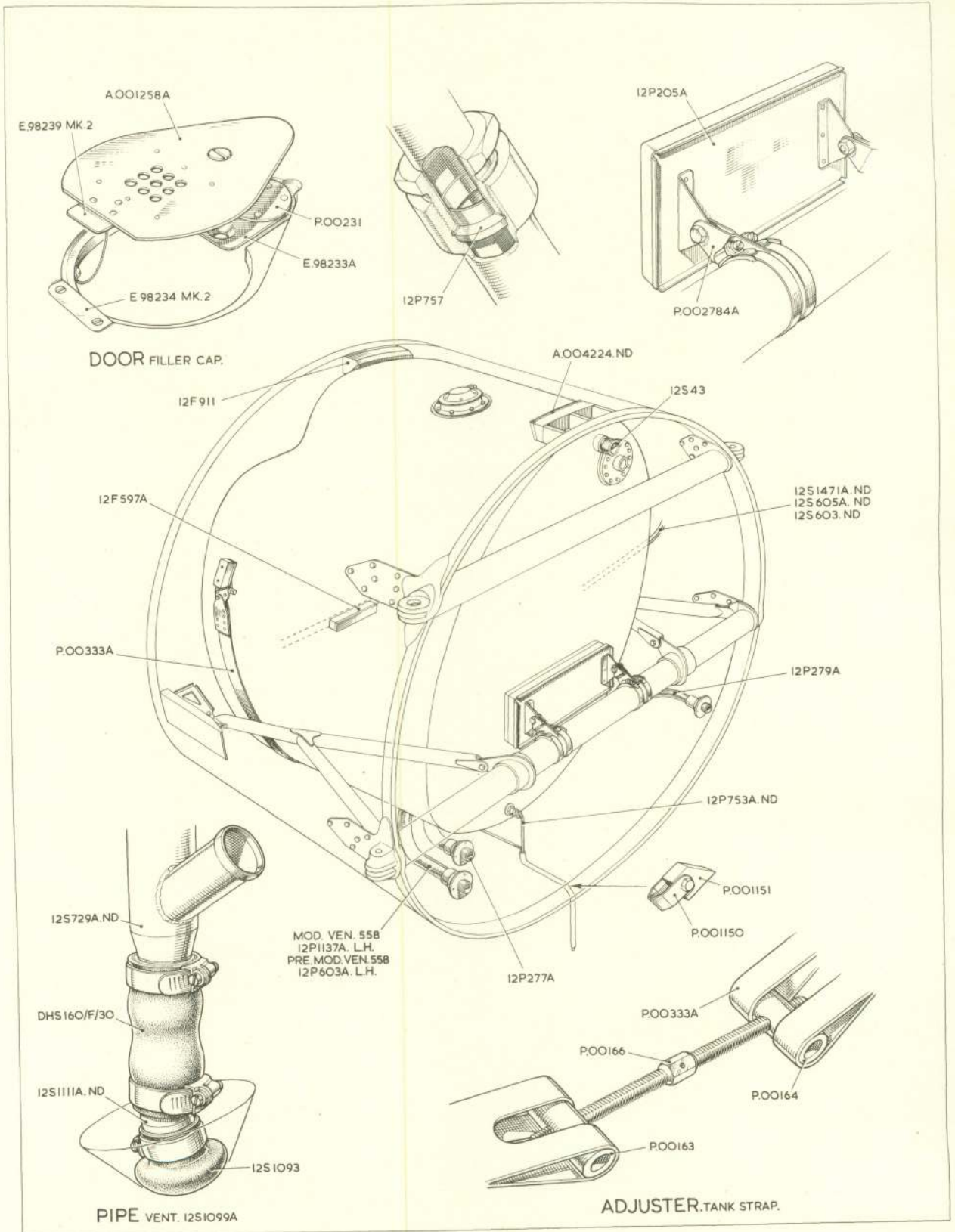

H.2.

**FUEL SYSTEM  
PIPES AND FITTINGS IN  
FUSELAGE AND AT ENGINE**

H.2.

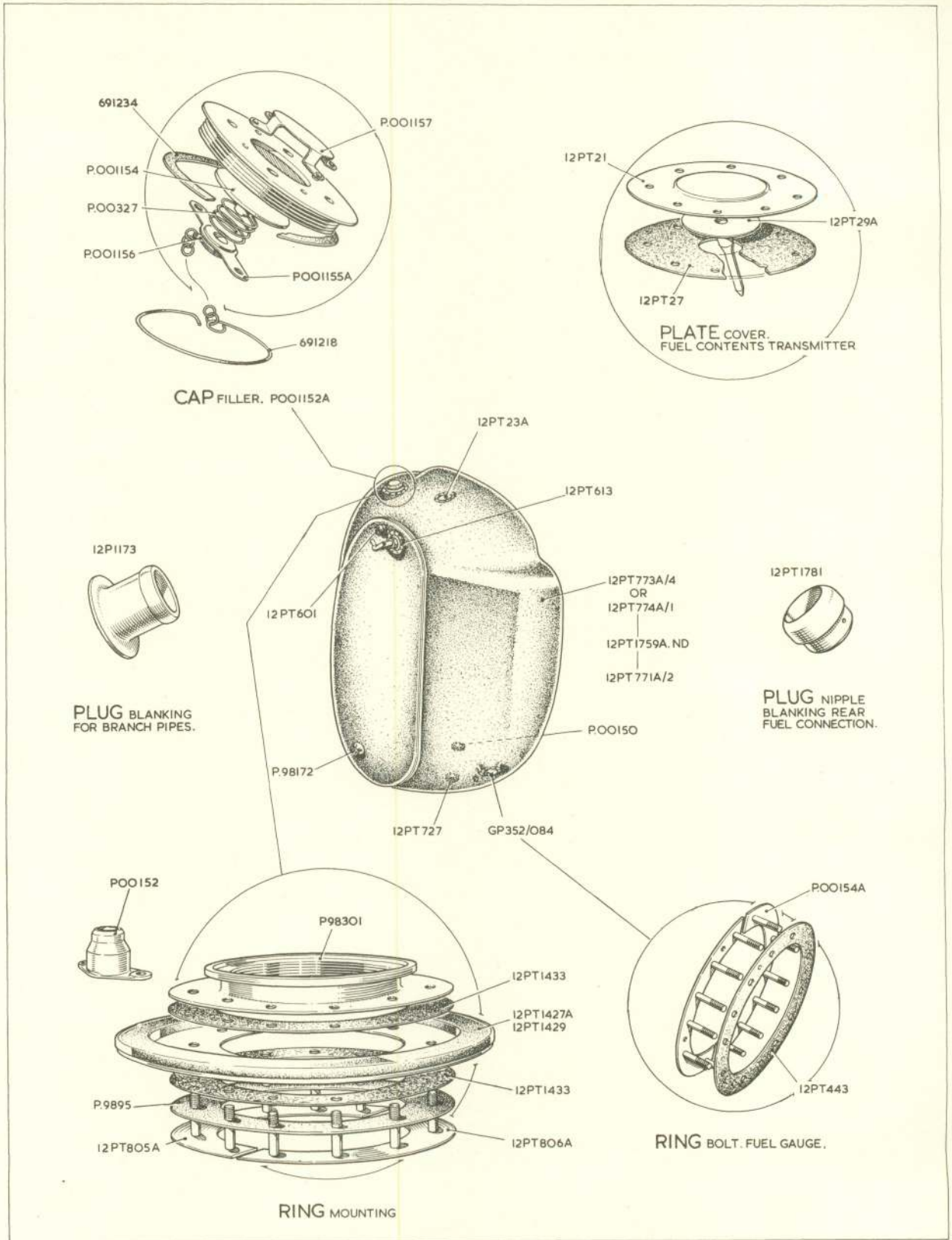

HA.I.

# FUEL SYSTEM

HA.I.

## FUSELAGE TANK

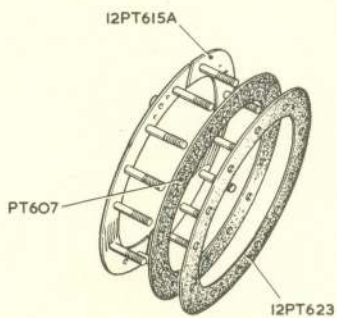

RING BOLT FOR FUEL VALVE.

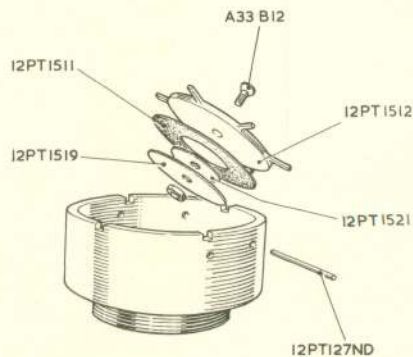

VALVE NON-RETURN.

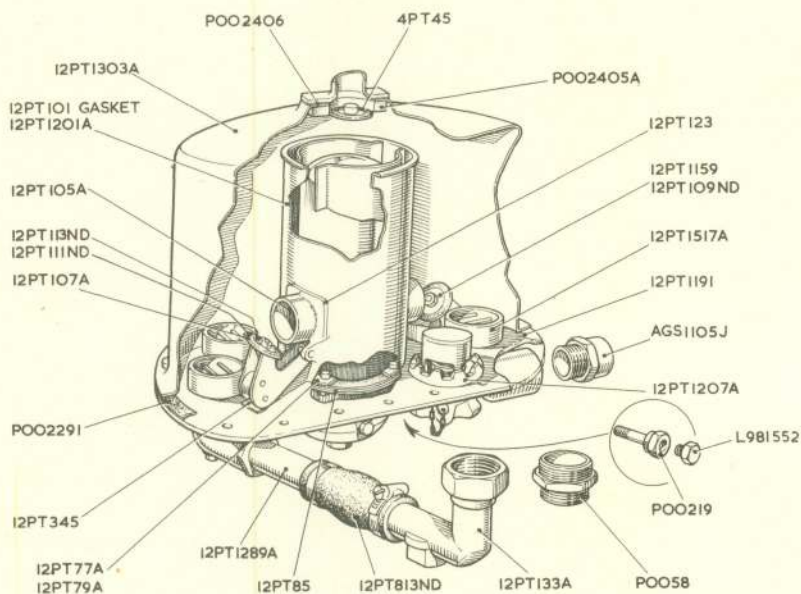

PUMP BOOSTER COMPLETE WITH VALVE - BP.3 MK.3 OR POL.403 MK.1.

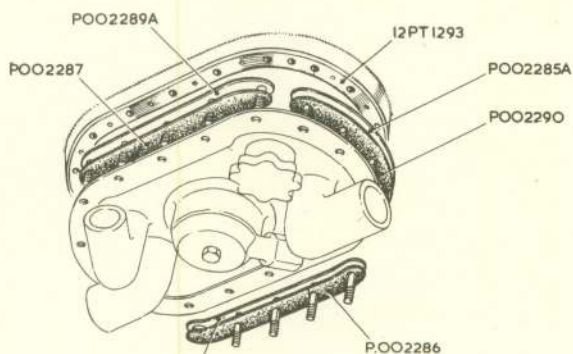

PLATES BOLT FOR BOOSTER PUMP.

HA.2.

# FUEL SYSTEM

## FUSELAGE TANK

HA.2.

HB.1.

PIPES AND FITTINGS IN WING

FUEL SYSTEM

HB.1.

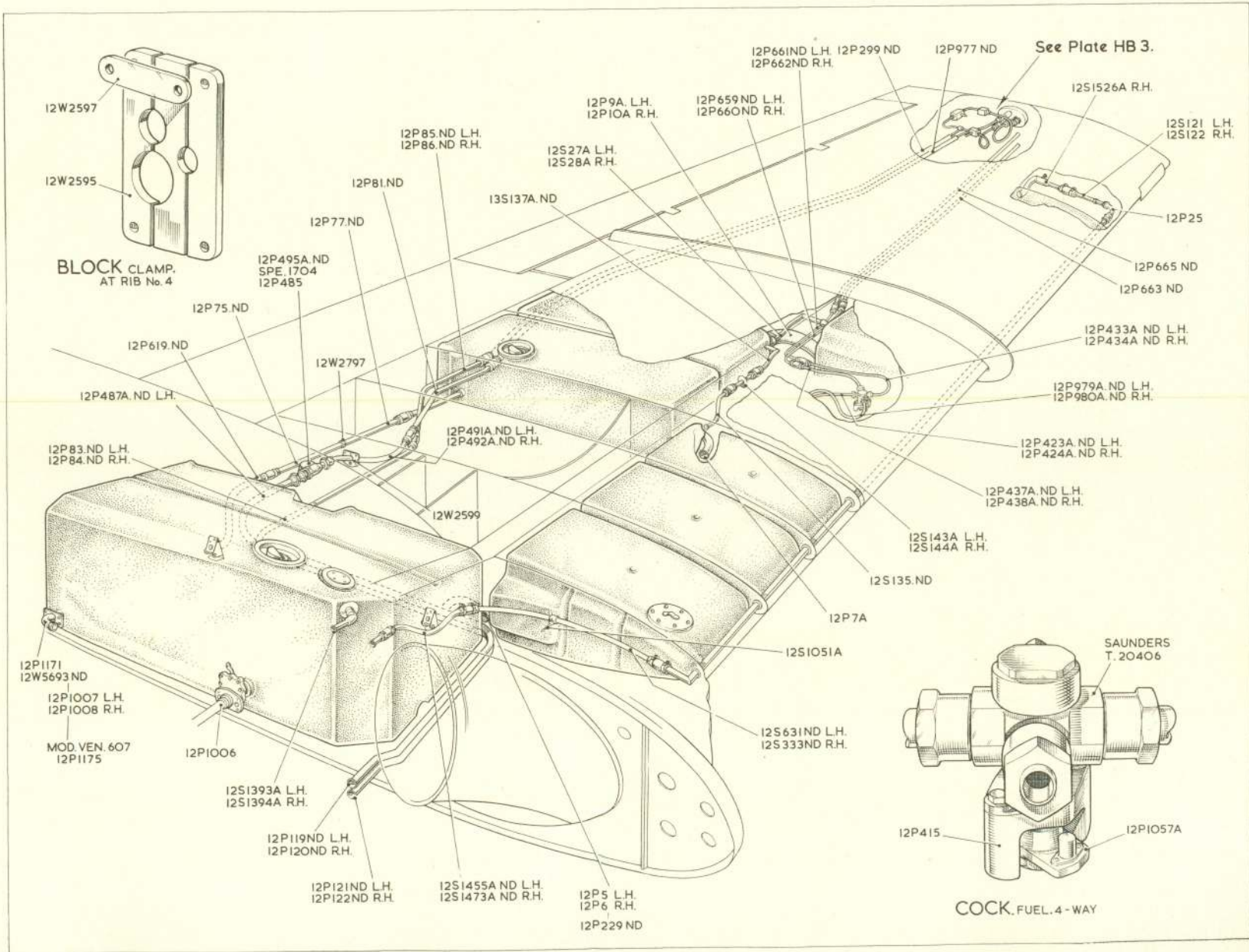

RESTRICTED

Venom FB Mk. 4

RESTRICTED

Plate HB1

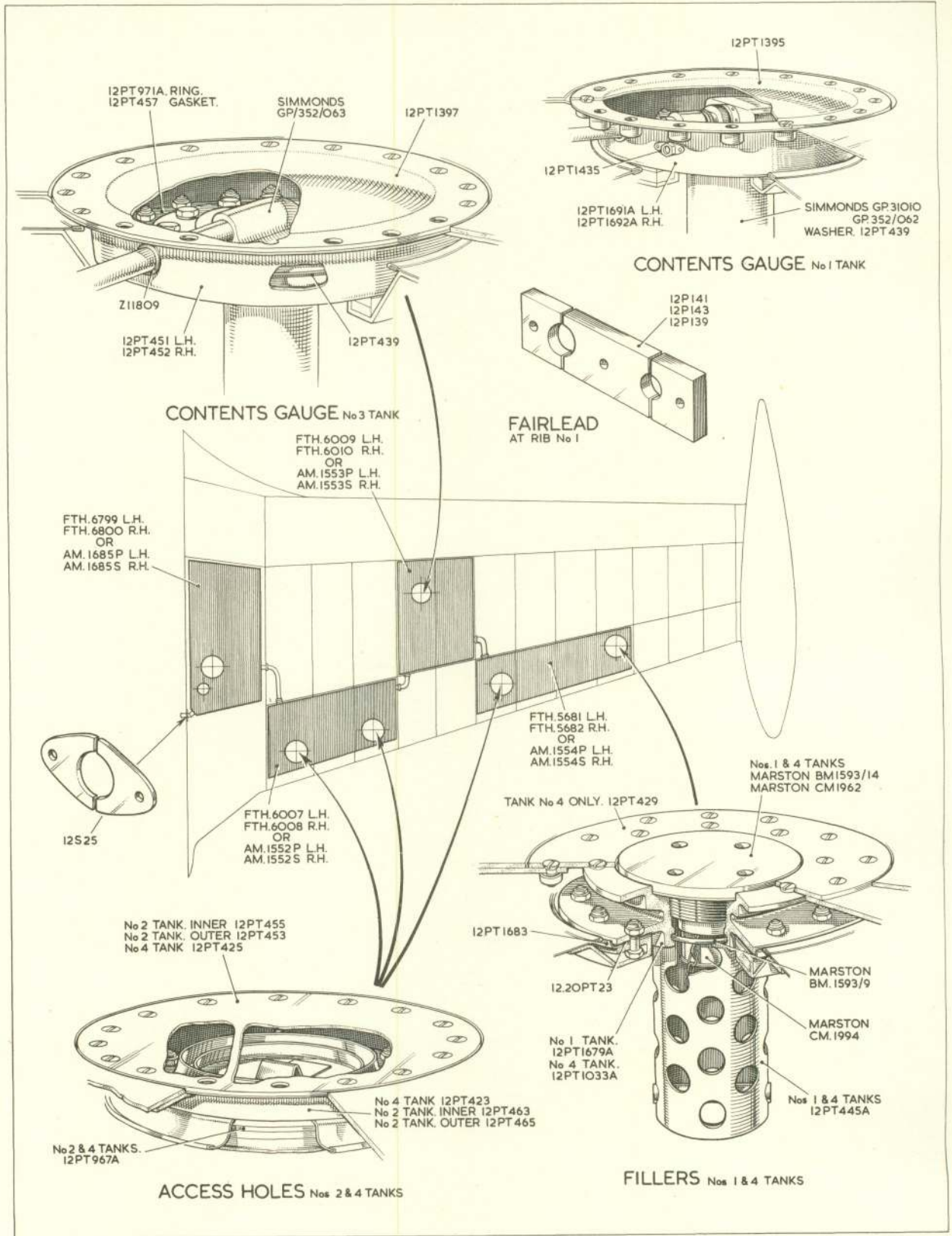

HB.2.

# FUEL SYSTEM

HB.2.

## PIPES AND FITTINGS IN WING

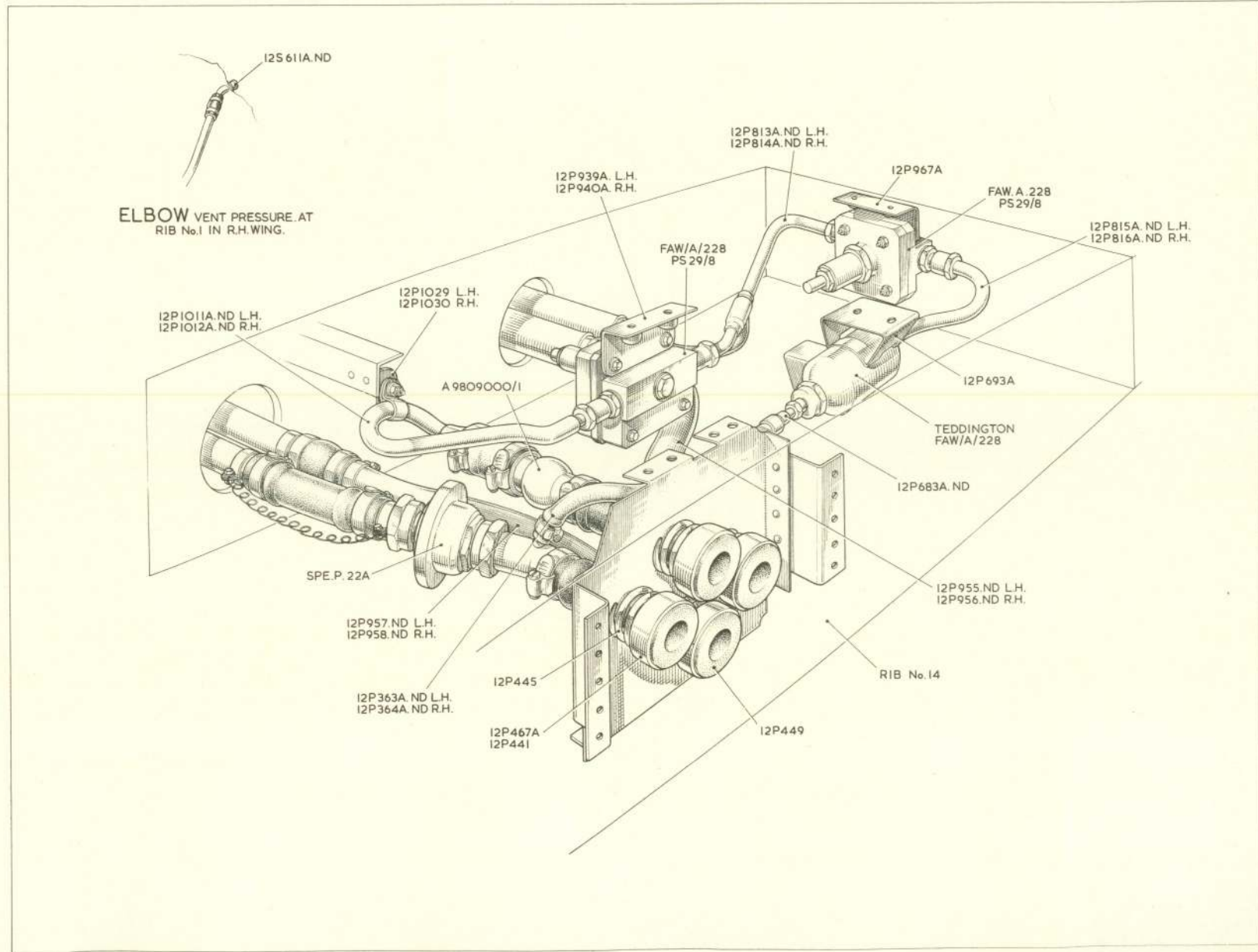

ELBOW VENT PRESSURE AT RIB No.1 IN R.H.WING.

HB.3.

# FUEL SYSTEM

## PIPES AND FITTINGS IN WING

RESTRICTED

HB.3.

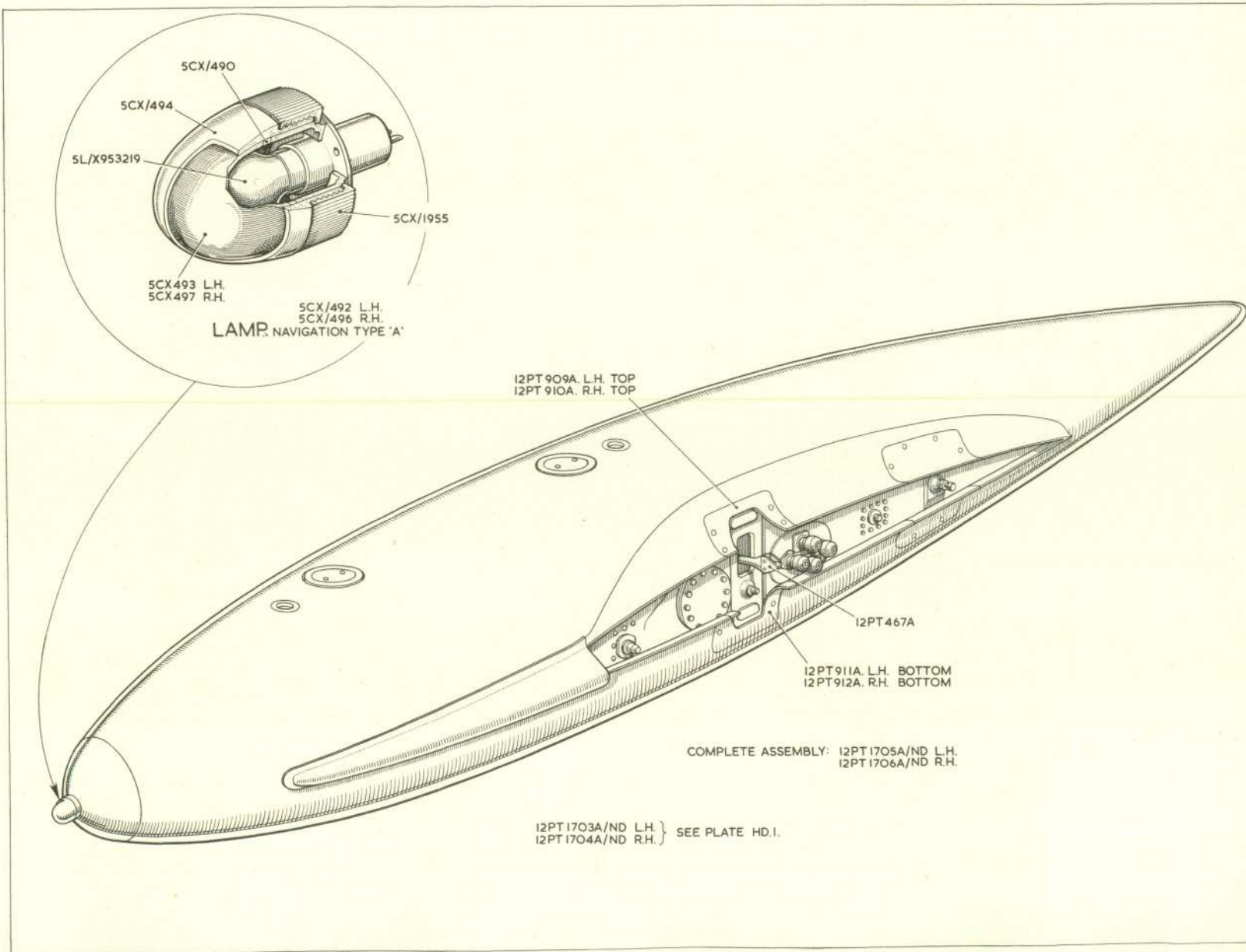

HC.1.

**FUEL SYSTEM**  
**75 GALLON WING TIP TANK**  
**INSTALLATION**

RESTRICTED

HC.1.

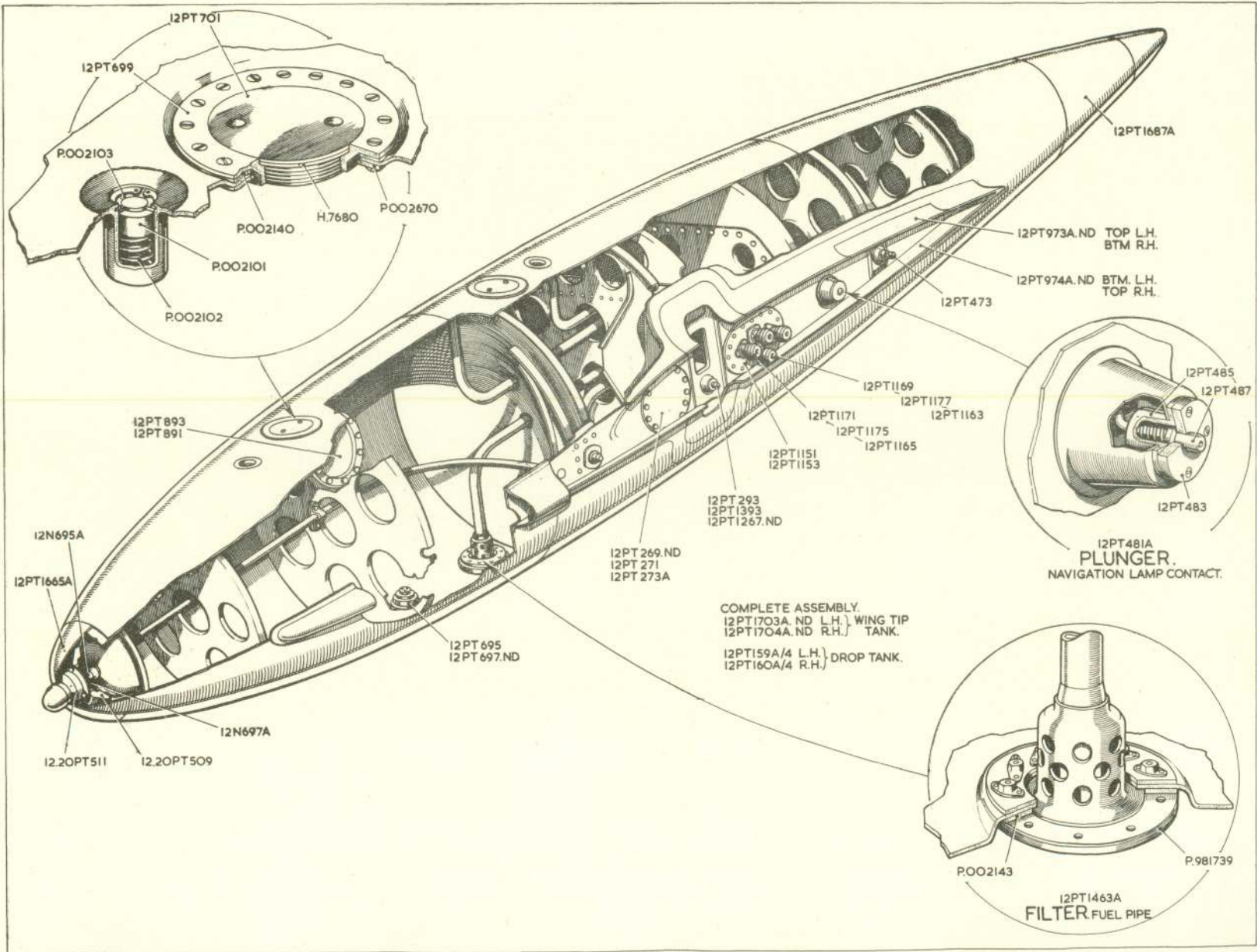

COMPLETE ASSEMBLY.  
 12PT1703A.ND L.H. } WING TIP  
 12PT1704A.ND R.H. } TANK.  
 12PT159A/4 L.H. } DROP TANK.  
 12PT160A/4 R.H. }

HD.1

# FUEL SYSTEM

HD.1

## 75 GALLON WING TIP TANK

RESTRICTED

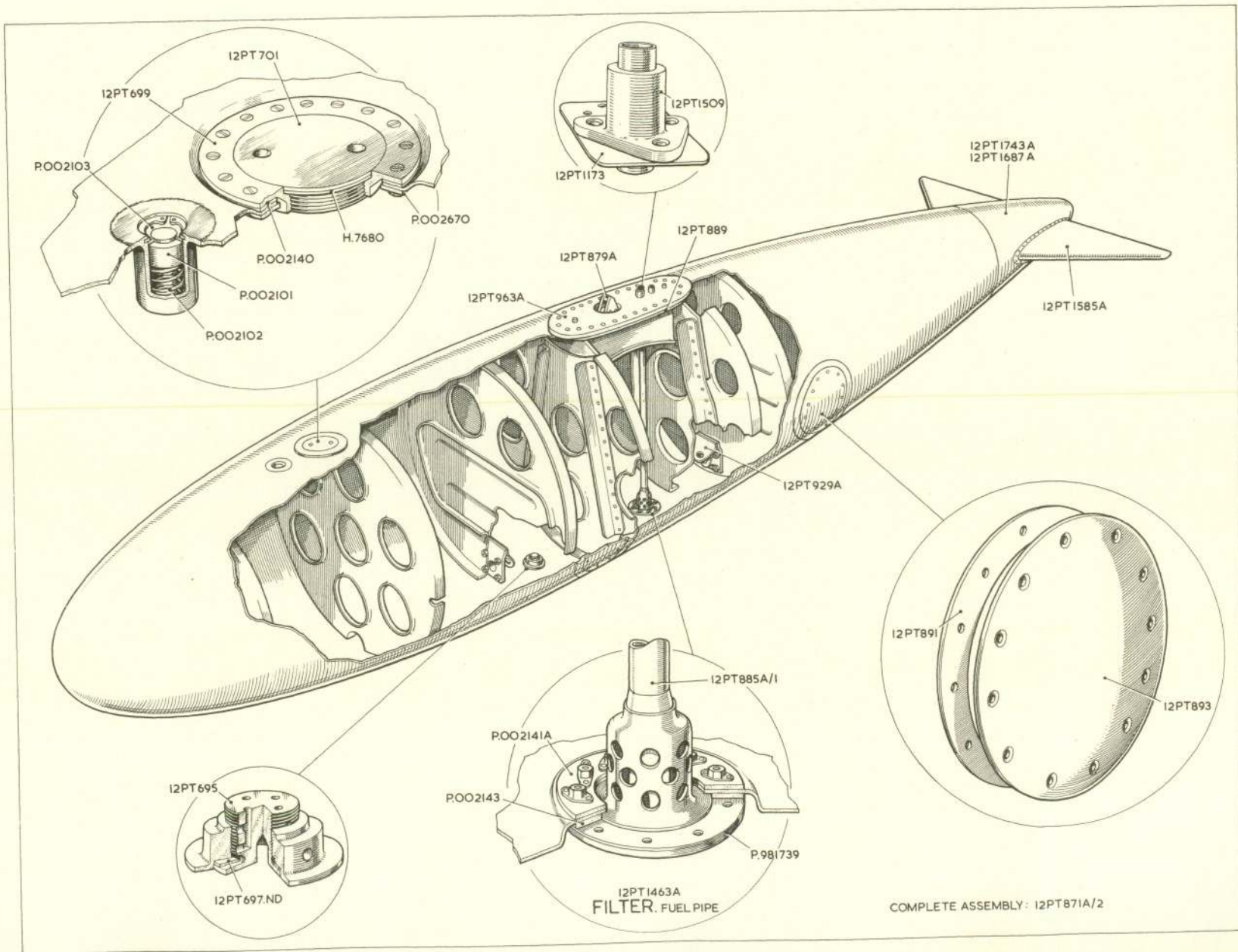

HE.I.

# FUEL SYSTEM

## PYLON DROP TANK

RESTRICTED

HE.I.

## HAND INK ALTERATIONS

Insert in the "Plate No." Column the following plate numbers against the undermentioned Part Numbers :-

## PAGE H.1

Ref. No.	Part No.	Plate No.	Ref. No.	Part No.	Plate No.
2849	12 P 973	H.1	5771	12 P 529	H.1
26FC/1819	P.00166	H.2	8107	F/S6000/1	H.1
1480	12 F 911	H.2	1545	12 P 319A	H.1
7718	12 F 597A	H.2	483	12 S 41A	H.1
26FC/3772	P.002784A	H.2	484	12 S 43	H.1

## PAGE H.2

Ref. No.	Part No.	Plate No.	Ref. No.	Part No.	Plate No.
	DHS.160/G/30	H.2	4851	12 P 549A/ND	H.1
8215	12 P 531	H.1	2945	12 P 575A/ND	H.1
5895	12 P 533	H.1	9249	12 S 1815A/ND	H.1
26FC/1891	A.001258A	H.2	9250	12 S 1817A/ND	H.1
	E.98239 Mk.2	H.2	7317	12 P 1137A	H.2
	P.00231	H.2	1698	12 P 603A	H.2
896	12 P 279A	H.2	894	12 P 277A	H.2

## PAGE H.3

Ref. No.	Part No.	Plate No.	Ref. No.	Part No.	Plate No.
466	12 P 21A	H.1	6600	E.98234 Mk.2	H.2
7127	12 P 1223ND	H.1	462	12 F 195	H.1
7126	12 P 1121ND	H.1	891	12 P 271	H.1
1546	12 P 329ND	H.1	26BY/270	E.98233A	H.2
480	12 P 151ND	H.1	7278	12 P 205A	H.2
6644	12 S 1469A/ND	H.1			
6026	12 S 1423A/ND	H.1			

## PAGE H.4

Ref. No.	Part No.	Plate No.	Ref. No.	Part No.	Plate No.
26FC/1973	P.00333A	H.2	2936	12 P 535	H.1
	P.001150	H.2	26FC/1929	P.00163	H.2
	P.001151	H.2	26FC/1930	P.00164	H.2
5883	SP.910/22	H.1	1699	12 P 757	H.2
461	12 F 193	H.1	4067	12 P 853	HA.1
470	12 P 71	H.1	4071	12 S 1085	HA.1

## PAGE HA.1

Ref. No.	Part No.	Plate No.	Ref. No.	Part No.	Plate No.
	12 PT 773A/7	HA.1	26FC/2290	P.00327	HA.1
	12 PT 774A/4	HA.1	26FC/2960	P.001154	HA.1
28F/12747	AGS.1105/J	HA.2	1703	12 PT 1201A	HA.2
26FC/2266	P.0058	HA.2		12 PT 813ND	HA.2
1702	12 PT 1191	HA.2	555	12 PT 133A	HA.2
26FC/2267	P.00219	HA.2	1700	12 PT 1289A	HA.2
26FC/2958	P.001152A	HA.1	1701	12 PT 1295	HA.2
	P.001155A	HA.1	26FC/3300	P.002289A	HA.2
26FC/2959	P.001157	HA.1	26FC/330	P.002285A	HA.2
	P.001156	HA.1	552	12 PT 21	HA.1
26BY/6376	691218	HA.1			

RESTRICTED

Issued with AL/2

PART 1

Venom FB Mk.4

HAND INK ALTERATIONS

Insert in the "Plate No." Column the following plate Numbers against the undermentioned Part Numbers :-

PAGE HA.2

Ref. No.	Part No.	Plate No.	Ref. No.	Part No.	Plate No.
2291	12 PT 1427A	HA.1	8096	12 PT 1781	HA.1
26FC/6890	12 PT 1429	HA.1	1705	12 PT 1303	HA.2
501	12 PT 77A	HA.2	26BY/1020	P.98301	HA.1
502	12 PT 79A	HA.2	893	12 PT 615A	HA.2
554	12 PT 29A	HA.1	26FC/2287	P.00154A	HA.1
8095	12 P 1173	HA.1	558	12 PT 805A	HA.1
26BY/2542	L.981552	HA.2	559	12 PT 806A	HA.1

PAGE HA.3

Ref. No.	Part No.	Plate No.	Ref. No.	Part No.	Plate No.
1704	12 PT 1207	HA.2	2883	12 PT 1517A	HA.2
	12 PT 771A/3	HA.1		12 PT 127ND	HA.2
	12 PT 771A/2	HA.1		12 PT 1515	HA.2
514	12 PT 601	HA.1		12 PT 1512	HA.2
26FC/2277	P.00150	HA.1	28S/2809	A.33/B12	HA.2
26BY/7985	P.98172	HA.1	2884	12 PT 1511	HA.2
516	12 PT 727	HA.1		12 PT 1519	HA.2
	12 PT 1293	HA.2		12 PT 1521	HA.2
890	12 PT 613	HA.1	26FC/3303	P.002405A	HA.2
512	12 PT 23A	HA.1	26FN/1388	4 PT 45	HA.2
26FC/2279	P.00152	HA.1			

PAGE HA.4

Ref. No.	Part No.	Plate No.	Ref. No.	Part No.	Plate No.
507	12 PT 105A	HA.2	26FC/3316	P.002286	HA.2
	12 PT 107A	HA.2	26FC/3297	P.002290	HA.2
	12 PT 1159	HA.2	26FC/3298	P.002291	HA.2
	12 PT 109ND	HA.2	26BY/1021	691234	HA.1
	12 PT 113ND	HA.2	2292	12 PT 1433	HA.1
508	12 PT 111ND	HA.2	26BY/6379	P.9895	HA.1
509	12 PT 345	HA.2	887	12 PT 623	HA.2
510	12 PT 123	HA.2	889	12 PT 607	HA.2
26FC/3317	P.002287	HA.2	556	12 PT 443	HA.1
26FC/3296	P.002406	HA.2	553	12 PT 27	HA.1
505	12 PT 101	HA.2	503	12 PT 85	HA.2
6A/2925	GP.352/084	HA.1			

PAGE HB.1

Ref. No.	Part No.	Plate No.	Ref. No.	Part No.	Plate No.
655	12 S 143A	HB.1		12 P 939A	HB.3
656	12 S 144A	HB.1		12 P 940A	HB.3
6A/3822	GP.31010	HB.2		12 P 967A	HB.3
663	12 W 2595	HB.1	8323	12 P 1029	HB.3
	12 W 2597	HB.1	8324	12 P 1030	HB.3
664	12 W 2599	HB.1			
	12 P 229ND	HB.1			
646	12 S 25	HB.2			

## HAND INK ALTERATIONS

Insert the "Plate No." Column in the following plate numbers against the undermentioned Part Numbers :-

## PAGE HB.2

Ref. No.	Part No.	Plate No.	Ref. No.	Part No.	Plate No.
	12 P 693A	HB.3	26FC/6414	BM.1593/9	HB.2
610	12 PT 445A	HB.2		12 W 2797	HB.1
26FC/4314	BM.1593/14	HB.2	27F/2429	T.20406	HB.1
26FC/4238	CM.1994	HB.2			

## PAGE HB.3

Ref. No.	Part No.	Plate No.	Ref. No.	Part No.	Plate No.
2823	12 P 1006	HB.1	1776	12 P 467A	HB.3
2824	12 P 1007	HB.1		12 P 441	HB.3
2825	12 P 1008	HB.1	1775	12 P 449	HB.3
6022	12 S 1393A	HB.1	9311	12 PT 1435	HB.2
6023	12 S 1394A	HB.1	467	12 P 25	HB.1

## PAGE HB.4

Ref. No.	Part No.	Plate No.	Ref. No.	Part No.	Plate No.
962	12 S 611A/ND	HB.3	5926	12 P 683A/ND	HB.3
5999	12 S 1526A	HB.1	636	12 P 83ND	HB.1
	12 P 141	HB.2	637	12 P 84ND	HB.1
	12 P 143	HB.2	638	12 P 85ND	HB.1
	12 P 139	HB.2	639	12 P 86ND	HB.1
3231	12-20PT 23	HB.2	640	12 P 119ND	HB.1
5X/2781	Z.11809	HB.2	641	12 P 120ND	HB.1
	12 P 1057	HB.1	5927	12 P 813A/ND	HB.3
5473	12 PT 1679A	HB.2	5928	12 P 814A/ND	HB.3
3889	12 PT 1033A	HB.2	621	12 P 5	HB.1

## PAGE HB.5

Ref. No.	Part No.	Plate No.	Ref. No.	Part No.	Plate No.
622	12 P 6	HB.1	5934	12 P 958ND	HB.3
623	12 P 7A	HB.1	5941	12 P 1011A/ND	HB.3
624	12 P 9A	HB.1	5942	12 P 1012A/ND	HB.3
625	12 P 10A	HB.1	1570	12 P 663ND	HB.1
631	12 P 75ND	HB.1	1571	12 P 665ND	HB.1
1577	12 P 619ND	HB.1	5923	12 P 437A/ND	HB.1
5929	12 P 815A/ND	HB.3	5924	12 P 438A/ND	HB.1
5930	12 P 816A/ND	HB.3	5921	12 P 433A/ND	HB.1
5931	12 P 955ND	HB.3	5922	12 P 434A/ND	HB.1
5932	12 P 956ND	HB.3	5935	12 P 979A/ND	HB.1
5917	12 P 363A/ND	HB.3	5936	12 P 980A/ND	HB.1
5918	12 P 364A/ND	HB.3	5919	12 P 423A/ND	HB.1
5933	12 P 957ND	HB.3	5920	12 P 424A/ND	HB.1

RESTRICTED

Issued with A/L2

PART 1

Venom FB Mk.4

HAND INK ALTERATIONS

Insert in the "Plate No." Column the following plate numbers against the undermentioned Part Numbers :—

PAGE HB.6

Ref. No.	Part No.	Plate No.	Ref. No.	Part No.	Plate No.
635	12 P 81ND	HB.1	647	12 S 27A	HB.1
642	12 P 121ND	HB.1	648	12 S 28A	HB.1
643	12 P 122ND	HB.1	653	12 S 135ND	HB.1
1562	12 P 487A/ND	HB.1	654	12 S 137A/ND	HB.1
1564	12 P 491A/ND	HB.1	659	12 S 333ND	HB.1
1565	12 P 492A/ND	HB.1	958	12 S 631ND	HB.1
1566	12 P 659ND	HB.1	6642	12 S 1455A/ND	HB.1
1567	12 P 660ND	HB.1	6645	12 S 1473A/ND	HB.1
1568	12 P 661ND	HB.1	614	12 PT 455	HB.2
1569	12 P 662ND	HB.1	613	12 PT 453	HB.2
	12 P 977ND	HB.1	604	12 PT 425	HB.2
	12 P 299ND	HB.1	1953	12 PT 1395	HB.2

PAGE HB.7

Ref. No.	Part No.	Plate No.	Ref. No.	Part No.	Plate No.
1954	12 PT 1397	HB.2		12 PT 1691A	HB.2
973	12 PT 967A	HB.2		12 PT 1692A	HB.2
606	12 PT 429	HB.2	603	12 PT 423	HB.2
8106	12 P 1175	HB.1	618	12 PT 463	HB.2
8742	12 P 1171	HB.1	619	12 PT 465	HB.2
	12 W 5693ND	HB.1	611	12 PT 451	HB.2
5474	12 PT 1683	HB.2	612	12 PT 452	HB.2

PAGE HB.8

Ref. No.	Part No.	Plate No.	Ref. No.	Part No.	Page No.
974	12 PT 971A	HB.2	8476	AM.1685P	HB.2
615	12 PT 457	HB.2	8477	AM.1685S	HB.2
1934	12 P 445	HB.3	1461	FTH.6007	HB.2
	12 S 1051A	HB.1	1462	FTH.6008	HB.2
	12 P 415	HB.1	2920	AM.1552P	HB.2
2975	FTH.6799	HB.2	2921	AM.1552S	HB.2
2974	FTH.6800	HB.2			

PAGE HB.9

Ref. No.	Part No.	Plate No.	Ref. No.	Part No.	Plate No.
1463	FTH.6009	HB.2	6A/2927	GP/352/063	HB.2
1464	FTH.6010	HB.2	609	12 PT 439	HB.2
2922	AM.1553P	HB.2	5946	SPE.P22A	HB.3
2923	AM.1553S	HB.2	27F/2401	A.9809000/1	HB.3
	FTH.5681	HB.2	27V/3462	FAW/A/228	HB.3
	FTH.5682	HB.2	27VB/4360	PS.29/8	HB.3
2924	AM.1554P	HB.2		12 P 495A/ND	HB.1
2925	AM.1554S	HB.2	27F/2155	SPE.1704	HB.1
6A/2926	GP/352/062	HB.2	1561	12 P 485	HB.1

## HAND INK ALTERATIONS

Insert in the "Plate No." Column the following plate numbers against the undermentioned Part Numbers :—

## PAGE HC.1

Ref. No.	Part No.	Plate No.	Ref. No.	Part No.	Plate No.
875	12 PT 911A	HC.1	5CX/497	†	HC.1
876	12 PT 912A	HC.1	5CX/493	†	HC.1
873	12 PT 909A	HC.1	5CX/1955	†	HC.1
874	12 PT 910A	HC.1	5CX/490	†	HC.1
5L/X953219	†	HC.1	6010	12 PT 1705A/ND	HC.1
5CX/492	†	HC.1	6011	12 PT 1706A/ND	HC.1
5CX/496	†	HC.1	10359	12 PT 467A/1	HC.1
5CX/494	†	HC.1		12 PT 1703A/ND	HC.1
				12 PT 1704A/ND	HC.1

## PAGE HD.1

Ref. No.	Part No.	Plate No.	Ref. No.	Part No.	Plate No.
	12 PT 1703A/ND	HD.1	2888	12 PT 160A/4	HD.1
	12 PT 1704A/ND	HD.1	1795	12 PT 701	HD.1
4094	12 PT 473	HD.1	2927	12 PT 1665A	HD.1
	12 N 697A	HD.1		12 PT 1169	HD.1
	12 N 695A	HD.1		12 PT 1177	HD.1
1741	12 PT 481A	HD.1		12 PT 1163	HD.1
	12 PT 485	HD.1	4101	12 PT 1171	HD.1
	12 PT 483	HD.1	4103	12 PT 1175	HD.1
	12 PT 487	HD.1	4102	12 PT 1165	HD.1
2887	12 PT 159A/4	HD.1		12 PT 893	HD.1

## PAGE HD.2

Ref. No.	Part No.	Plate No.	Ref. No.	Part No.	Plate No.
1011	12 PT 974A/ND	HD.1	2926	12-20PT 511	HD.1
1010	12 PT 973A/ND	HD.1	787	12 PT 695	HD.1
2344	12 PT 1463A	HD.1	26FC/8735	P.002101	HD.1
26FC/6525	P.981739	HD.1	789	12 PT 699	HD.1
26FC/3816	P.002143	HD.1	26FC/4099	P.002670	HD.1
	12 PT 1151	HD.1	26FC/3818	P.002140	HD.1
4106	12 PT 1153	HD.1		12 PT 273A	HD.1
781	12 PT 269ND	HD.1	26FC/10338	P.002103	HD.1
782	12 PT 271	HD.1		12 PT 1267ND	HD.1

## PAGE HD.3

Ref. No.	Part No.	Plate No.	Ref. No.	Part No.	Plate No.
783	12 PT 293	HD.1	788	12 PT 697ND	HD.1
26FC/8736	P.002102	HD.1	4100	12 PT 1393	HD.1
				12-20PT 509	HD.1

RESTRICTED

Issued with AL/2

PART 1

Venom FB Mk.4

HAND INK ALTERATIONS

Insert in the "Plate No." Column the following plate numbers against the undermentioned Part Numbers :—

PAGE HE.1

Ref. No.	Part No.	Plate No.	Ref. No.	Part No.	Plate No.
8750	12 PT 871A/3	HE.1	26FC/3816	P.002143	HE.1
9245	12 PT 879A/1	HE.1		12 PT 893	HE.1
1795	12 PT 710	HE.1		12 PT 963A/1	HE.1
7198	12 PT 1743A	HE.1	787	12 PT 695	HE.1
9394	12 PT 1687A	HE.1	26FC/8735	P.002101	HE.1
	12 PT 1565A	HE.1		12 PT 885A/1	HE.1
	12 PT 1509	HE.1	789	12 PT 699	HE.1
2344	12 PT 1463A	HE.1	26FC/4099	P.002670	HE.1
26FC/6525	P.981739	HE.1	26FC/3818	P.002140	HE.1
				P.002141A	HE.1
788	12 PT 697ND	HE.1	26FC/10338	P.002103	HE.1

PAGE HE.2

Ref. No.	Part No.	Plate No.	Ref. No.	Part No.	Plate No.
26FC/8736	P.002102	HE.1		12 PT 929A	HE.1
26BY/5925	H.7680	HE.1			

This file was downloaded  
from the RTFM Library.  
Link: [www.scottbouch.com/rtfm](http://www.scottbouch.com/rtfm)

Please see site for usage terms,  
and more aircraft documents.

