

FUSELAGE COMPLETE

Ref. No.	Part No.	Nomenclature						No. Off	M.R.	Cl. of St.	Plate No.
		1	2	3	4	5	6				
	—	<b>FUSELAGE COMPLETE (12 4F 1)</b> ... ..						1	—		J.1
	KELVIN & HUGHES										
6A/3599	KB 482/01	<b>ACCELEROMETER</b> , indicating (Mod. Ven. 273) (Pre Mod. Ven. 751)						1	—	A.	
6A/3451	†	<b>ACCELEROMETER</b> , indicating Mk. 2, (Mod. Ven. 715)						1	—	A.	
10B/518	†	<b>AERIAL</b> , type 91, (attaching bolts supplied with aerial) (Mod. Ven. 328)						2	—	A.	
1302	12 A 333A	<b>ADAPTOR</b> , cannon heating pipe, at fireproof bulkhead Attaching parts for 12 A 333A, Adaptor :—						1	—	C.	J.7
28D/8306	AS.1242/1C	Bolt, 2 BA ... ..						3	—	C.	
28M/10288	AGS.2001/C/1	Nut, 2 BA ... ..						3	—	C.	
28W/12252	SP.13/C	Washer ... ..						3	—	C.	
	12 M 169	<b>ANGLE</b> , attachment, for bomb jettison cable conduit clamp block aft of bulkhead No. 3, R.H. 20 SWG, L.72						1	MR	—	J.5
9723	12 F 1631A	<b>ANGLE</b> , fillet attachment, bottom, L.H. (Mod. Ven. 938)						1	—	C.	J.1
9724	12 F 1632A	<b>ANGLE</b> , fillet attachment, bottom, R.H. (Mod. Ven. 938)						1	—	C.	J.1
10127	12 F 545A	<b>ANGLE</b> , fillet attachment, top, forward, L.H. ... (Mod. Ven. 938)						1	—	C.	J.1
10128	12 F 546A	<b>ANGLE</b> , fillet attachment, top, forward, R.H. ... (Mod. Ven. 938) Attaching parts for 12 F 1631A, 12 F 1632A, 12 F 545A/1 and 12 F 546A/1, Angles :—						1	—	C.	J.1
28L/11069	AGS.2035/C	Lockwasher ... ..						3	—	C.	
28S/2862	A.32/C.16	Screw, 2 BA ... ..						3	—	C.	
727	12 F 549A	<b>ANGLE</b> , fillet attachment, top, front, centre, L.H.						1	MR	C.	J.1
728	12 F 550A	<b>ANGLE</b> , fillet attachment, top, front, centre, R.H.						1	MR	C.	J.1
1557	12 F 863A	<b>ANGLE</b> , fillet attachment, top, rear, centre, L.H.						1	MR	C.	J.1
1558	12 F 864A	<b>ANGLE</b> , fillet attachment, top, rear, centre, R.H.						1	MR	C.	J.1
1559	12 F 865A	<b>ANGLE</b> , fillet attachment, top, rear, L.H. ...						1	MR	C.	J.1
1560	12 F 866A	<b>ANGLE</b> , fillet attachment, top, rear, R.H. ...						1	MR	C.	J.1
	A.001849A/ND	<b>ANGLE</b> , for detachable top nose fairing, on top of bulkhead No. 1, L.H. ...						1	—		J.3
	A.001848A/ND	<b>ANGLE</b> , for detachable top nose fairing, on top of bulkhead No. 1, R.H.						1	—		J.3
26FC/1822	A.001317A	<b>ANGLE</b> , landing, on cannon beam for cannon fairing, L.H.						1	—	C.	J.4
26FC/1823	A.001318A	<b>ANGLE</b> , landing, on cannon beam for cannon fairing, R.H.						1	—	C.	J.4
26FC/1824	A.001067A	<b>SPRING</b> , fastener, complete with plate ... ..						3	—	C.	J.4
27FP/353	No. 1-90 DZUS	<b>SPRING</b> ... ..						1	—	C.	
28W/12305	SP.13/B	<b>WASHER</b> ... ..						2	—	C.	
		Attaching parts for A.001317A and A.001318A, Angles :—									
28D/13105	A.25/26C	Bolt, 2 BA ... ..						7	—	C.	
28M/12929	A27/CP	Nut, 2 BA ... ..						7	—	C.	
26BY/6875	DHS.56 Mk. 3	Washer, 2 BA ... ..						5	—	C.	
26BY/5261	DHS.56 Mk. 18	Washer, 2 BA ... ..						2	—	C.	
26BY/3165	DHS.33 Mk. 1	Washer, 2 BA, shrinkage ... ..						14	—	C.	
6037	12 F 827ND	<b>BACKPLATE</b> , for ballast weight in nose, L.H., front lower Attaching parts for 12 F 827ND, Backplate :—						1	MR	C.	J.1
28D/8314	AS.1242/10C	Bolt, 2 BA ... ..						8	—	C.	
28M/10288	AGS.2001/C/1	Nut, 2 BA ... ..						8	—	C.	
28W/12588	SP.18/C	Washer ... ..						8	—	C.	

FUSELAGE

FUSELAGE COMPLETE

Ref. No.	Part No.	Nomenclature						No. Off	M.R.	Cl. of St.	Plate No.
		1	2	3	4	5	6				
6035	12 F 823ND	<b>BACKPLATE</b> , for ballast weight in nose, R.H. upper						1	MR	C.	
28D/8314	AS.1242/10C	Attaching parts for 12 F 823ND, Backplate :—						7	—	C.	
28M/10288	AGS.2001/C/1	Bolt, 2 BA ... ..						7	—	C.	
28W/12588	SP.18/C	Nut, 2 BA ... ..						7	—	C.	
		Washer ... ..						7	—	C.	
	12 F 1551	<b>BACKPLATE</b> , for bottom attachment of ejector seat						1	—		
		rail bracket, on rear face of bulkhead									
		No. 2 (Mod. Ven. 565)									
		Attaching parts for 12 F 1551, Backplate :—									
28D/12541	A25/24C	Bolt, 2 BA ... ..						8	—	C.	
28M/10288	AGS.2001/C/1	Nut, 2 BA ... ..						8	—	C.	
26BY/5871	DHS.34/C	Washer ... ..						6	—	C.	
26BY/7300	DHS.56 Mk. 1	Washer ... ..						2	—	C.	
26BY/3165	DHS.33 Mk. 1	Washer, shrinkage ... ..						16	—	C.	
9C/1	†	<b>BAG</b> , First Aid equipment ... ..						1	—	A.	
26FC/4646	A.001953A/1	<b>BEAM</b> , cannon, L.H. ... ..						1	MR	C.	J.1
26FC/12612	A.001954A/3	<b>BEAM</b> , cannon, R.H. (Mod. Ven. 328) ... ..						1	MR	C.	J.1
9595	A/MBEU/385V	<b>BLOCK</b> , anti vibration for ejector seat on cockpit						1	—	C.	
		floor, Port, Martin Baker									
		Attaching parts for A/MBEU/385V, Block :—									
28D/12537	A25/14C	Bolt, 2 BA ... ..						4	—	C.	
28M/10288	AGS.2001/C/1	Nut, 2 BA ... ..						4	—	C.	
28W/12252	SP.13/C	Washer ... ..						4	—	C.	
	12 F 1621	Washer, plate ... ..						1	—		
26BY/3165	DHS.33/1	Washer, shrinkage ... ..						8	—	C.	
7723	12 M 167	<b>BLOCK</b> , clamp, half, for bomb jettison cable conduit,						2	MR	C.	J.5
		aft of bulkhead, No. 3, R.H. ...									
		Attaching parts for 12 M 167, Block :—									
28D/12629	A25/8C	Bolt, 2 BA ... ..						3	MR	C.	
28M/10288	AGS.2001/C/1	Nut, 2 BA ... ..						2	MR	C.	
28W/12252	SP.13/C	Washer ... ..						2	MR	C.	
7719	12 M 31	<b>BLOCK</b> , clamp half, for drop tank jettison cable						4	MR	C.	J.5
		conduit, under cockpit floor and									
		bomb jettison cable conduit under									
		ammunition floor									
		Attaching parts for 12 M 31 Block :—(per pair)									
28D/12514	A25/7C	Bolt, 2 BA ... ..						1	MR	C.	
28M/10288	AGS.2001/C/1	Nut, 2 BA ... ..						1	MR	C.	
28W/12252	SP.13/C	Washer ... ..						1	MR	C.	
	12 F 835	<b>BLOCK</b> , mounting, for gyro gunsight recorder ...						1	—		J.1
		Attaching parts for 12 F 835, Block :—									
28D/12536	A25/13C	Bolt, 2 BA ... ..						2	—	C.	
28L/11069	AGS.2035/C	Lockwasher ... ..						2	—	C.	
28W/12252	SP.13/C	Washer ... ..						2	—	C.	
	12 FS 889	<b>BLOCK</b> , packing, attached to strap plate between						2	—		
		engine locating eyebolts centre of									
		fireproof bulkhead									
		Attaching parts for 12 FS 889, Block :—									
28D/8326	AS.1242/5E	Bolt, 1/4" BSF ... ..						1	—	C.	
28L/12931	A27/ET	Locknut, 1/4" BSF ... ..						1	—	C.	
28D/12539	A25/16C	<b>BOLT</b> , 2 BA, securing fireproof, bulkhead to fuselage						26	MR	C.	
		bulkhead ring									

FUSELAGE COMPLETE

Ref. No.	Part No.	Nomenclature						No. Off	M.R.	Cl. of St.	Plate No.
		1	2	3	4	5	6				
26FC/1836	B.00162	<b>BOLT</b> , swivel, locking door in front armour bulkhead No. 1						2	—	C.	
26FC/5812	B.00164	Attaching parts for B.00162 Bolt :—									
28P/12462	SP.9/C8	Pin ... ..						1	—	C.	
		Pin, split ... ..						1	—	C.	
28D/12630	12 M 427A/ND	<b>BOX</b> , control, bomb jettison, complete (Mod. Ven. 273)						1	—		J.5
	A25/19C	<b>BOLT</b> , securing control box ... ..						2	—	C.	J.5
	12 M 323A/ND	<b>BOX</b> , control (Make from Teleflex Part No. C.39700)						1	—		
	12 M 341ND	<b>NIPPLE</b> (Make from Teleflex Part No. A.821, with hole drilled $\frac{5}{16}$ " )						1	—		J.5
	12 M 319ND	<b>TUBE</b> , spent travel $\frac{5}{16}$ " o/d. $\times$ 22G, L.54 ...						2	—		J.5
1677	12 M 179	<b>BRACKET</b> , mounting ... ..						1	—	C.	J.5
1678	12 M 183	<b>EYE-BOLT</b> ... ..						1	—	C.	J.5
28L/13124	A27/CT	<b>LOCKNUT</b> , 2 BA, for lever stop screw ... ..						1	—	C.	
28M/10288	AGS.2001/C/1	<b>NUT</b> , 2 BA, securing control box ... ..						3	—	C.	
28S/2778	A31/C24	<b>SCREW</b> , 2 BA, for lever stop ... ..						1	—	C.	
	12 M 181ND	<b>TUBE</b> , spacing, $\frac{5}{16}$ " o/d $\times$ 20G $\times$ "20 long, T.9						6	—		J.5
		Attaching parts for 12 M 427A/ND, Box :—									
28D/11564	AS.1246/1C	Bolt, 2 BA ... ..						5	—	C.	
28L/11069	AGS.2035/C	Washer ... ..						5	—	C.	
28D/12630	12 M 329A/ND	<b>BOX</b> , control, wing tip tank jettison, complete ...						1	—		
	A25/19C	<b>BOLT</b> , securing control box ... ..						2	—	C.	
	12 M 327A/ND	<b>BOX</b> , control ... ..						1	—		
27K/—	C.39697	<b>BOX</b> , control, Teleflex ... ..						1	—	C.	
	12 M 341ND	<b>NIPPLE</b> (Make from Teleflex Part No. A.821 with hole drilled $\frac{5}{16}$ " )						1	—		
	12 M 317ND	<b>TUBE</b> , spent travel ( $\frac{5}{16}$ " o/d $\times$ 22G, L.54)						2	—		
1689	12 M 245	<b>BRACKET</b> , mounting ... ..						1	—	C.	
1678	12 M 183	<b>EYE-BOLT</b> ... ..						1	—	C.	
28L/13124	A27/CT	<b>LOCKNUT</b> , for lever stop screw ... ..						1	—	C.	
28M/10288	AGS.2001/C/1	<b>NUT</b> , 2 BA, securing control box ... ..						3	—	C.	
28S/2778	A31/C24	<b>SCREW</b> , 2 BA, for lever stop ... ..						1	—	C.	
	12 M 181ND	<b>TUBE</b> , spacing, $\frac{5}{16}$ " o/d $\times$ 20G $\times$ 0-"20 long, T.9						6	—		
		Attaching parts for 12 M 329A/ND, Box :—									
28D/11564	AS.1246/1C	Bolt, 2 BA ... ..						4	—	C.	
28L/11069	AGS.2035/C	Washer ... ..						4	—	C.	
10D/18876	†	<b>BOX</b> , junction, mounted in front of TR.3708 receiver in fixed nosing, type 397 (Mod. Ven. 328)						1	—	A.	
		Attaching parts for 10D/18876 Box :—									
28S/2761	A31/B12	Screw, 4 BA ... ..						4	—	C.	
	A.005121	<b>BRACKET</b> , ammunition door stay ... ..						1	—		J.6
		Attaching parts for A.005121 :—									
28D/12733	AS.2920/6C	Bolt, 2 BA ... ..						2	—	C.	
28M/10288	AGS.2001/C/1	Nut, 2 BA ... ..						2	—	C.	
28W/12252	SP.13/C	Washer ... ..						2	—	C.	
26FC/4881	B.003145	<b>BRACKET</b> , anchor, for elastic cord securing First Aid equipment bag, 16 SWG, S.84						2	—	C.	J.5
		Attaching parts for B.003145 Bracket :—									
28L/11069	AGS.2035/C	Lockwasher ... ..						1	—	C.	
28S/2856	A32/C12	Screw, 2 BA ... ..						1	—	C.	
26FC/1739	R.00248A	<b>BRACKET</b> , cannon heating pipe clip mounting ...						1	—	C.	J.7

FUSELAGE COMPLETE

Ref. No.	Part No.	Nomenclature						No Off.	M.R.	Cl. of St.	Place No.
		1	2	3	4	5	6				
26FC/1738	R.00238	<b>BRACKET</b> , cannon heating pipe support clamp mounting						1	—	C.	J.7
28D/12533	A25/5C	Attaching parts for R.00238 Bracket :—									
28M/10288	AGS.2001/C/1	Bolt, 2 BA ... ..						2	—	C.	
28W/12252	SP.13/C	Nut, 2 BA ... ..						2	—	C.	
		Washer ... ..						2	—	C.	
6072	12 A 599A	<b>BRACKET</b> , cannon heating support pipe, bulkhead No. 2						2	—	C.	J.7
		Attaching parts for 12 A 599A Bracket :—									
28S/2664	AGS.253/39	Screw ... ..						2	—	C.	
	12 V 1081	<b>BRACKET</b> , demister pipe mounting (Mod. Ven. 633)						1	—		
		Attaching parts for 12 V 1081 Bracket :—									
28D/12512	A25/1C	Bolt, 2 BA ... ..						2	—	C.	
28M/10288	AGS.2001/C/1	Nut, 2 BA ... ..						2	—	C.	
28W/12252	SP.13/C	Washer ... ..						QR	—	C.	
1657	12 FS 465	<b>BRACKET</b> , ejector seat mounting, lower, on bulkhead No. 2						1	—	C.	J.7
		Attaching parts for 12 FS 465 Bracket :—									
28D/13782	AS.1242/26G	Bolt, $\frac{5}{16}$ " BSF ... ..						4	—	C.	
28D/13926	AS.1242/15G	Bolt, $\frac{5}{16}$ " BSF ... ..						4	—	C.	
28M/10331	AGS.2002/G/1	Nut, $\frac{5}{16}$ " BSF, stiff ... ..						8	—	C.	
28W/12668	SP.19/G	Washer ... ..						4	—	C.	
26BY/3585	DHS.33 Mk. 3	Washer, shrinkage ... ..						16	—	C.	
1656	12 FS 469	<b>BRACKET</b> , ejector seat mounting, upper on guide rail						1	—	C.	J.8
		Attaching parts for 12 FS 469 Bracket :—									
28D/12674	A25/9E	Bolt, $\frac{1}{4}$ " BSF ... ..						2	—	C.	
28M/10290	AGS.2001/E/1	Nut, $\frac{1}{4}$ " ... ..						2	—	C.	
28W/12253	SP.13/E	Washer ... ..						2	—	C.	
	12 FS 939ND	Washer, packing, $\frac{3}{8}$ " o/d x 10G, L.72 ... ..						2	—		
1655	12 FS 471	<b>BRACKET</b> , ejector seat mounting, attached to upper bracket on guide rail						1	—	C.	J.8
		Attaching parts for 12 FS 471 Bracket :—									
28D/12812	A25/12E	Bolt, $\frac{1}{4}$ " BSF ... ..						2	—	C.	
28D/11997	AS.1242/14E	Bolt, $\frac{1}{4}$ " BSF ... ..						3	—	C.	
28M/10290	AGS.2001/E/1	Nut, $\frac{1}{4}$ " BSF ... ..						5	—	C.	
28W/12253	SP.13/E	Washer ... ..						5	—	C.	
	12 F 1357A	<b>BRACKET</b> , footrest support, L.H. mounted on cockpit floor						1	—		J.8
	12 F 1358A	<b>BRACKET</b> , footrest support R.H., mounted on cockpit floor						1	—		J.8
	12 N 1609	<b>BRACKET</b> , for cockpit lamp, under bend of de-misting pipe, cockpit port side						1	—		J.8
		Attaching parts for 12 N 1609 Bracket :—									
28M/10286	AGS.2001/A/1	Nut, 6 BA ... ..						2	—	C.	
28S/2858	A32/A12	Screw, 6 BA ... ..						2	—	C.	
	12 N 2369	<b>BRACKET</b> , for cockpit emergency light on gunsight bracket (Mod. Ven. 751)						1	—		
		Attaching parts for 12 A 2369 Bracket :—									
28D/12838	A28/1E	Bolt, $\frac{1}{4}$ " BSF ... ..						2	—	C.	
28L/11066	AGS.2035/A	Lockwasher ... ..						2	—	C.	
28L/11060	AGS.2037/E	Lockwasher ... ..						2	—	C.	
28S/14547	A32/A10	Screw, 6 BA ... ..						2	—	C.	
1777	12 F 961A	<b>BRACKET</b> , for meter range and heading indicator secured to E2A Compass bracket and canopy rail (Mod. Ven. 751)						1	—	C.	
	12 F 999ND	<b>CLIP</b> , half, 18 SWG, L.59 ... ..						1	—		
	12 F 1001ND	<b>CLIP</b> , half, 18 SWG, L.59 ... ..						1	—		
		Attaching parts for 12 F 961A, Bracket									
28M/10275	AGS.2001/C/4	Nut, brass, 2 BA ... ..						2	—	C.	
28S/2418	A44/C20	Screw, brass, 2 BA ... ..						1	—	C.	
28W/15117	SP.25/C	Washer ... ..						2	—	C.	
26FC/1927	B.00161	<b>BRACKET</b> , for swivel bolt on door in front armour, bulkhead No. 1						2	—	C.	J.3
		Attaching parts for B.00161 Bracket :—									
28D/12633	A25/7E	Bolt, $\frac{1}{4}$ " BSF ... ..						2	—	C.	
28M/12928	A27/EP	Nut, $\frac{1}{4}$ " BSF ... ..						2	—	C.	

## FUSELAGE COMPLETE

Ref. No.	Part No.	Nomenclature						No. Off	M.R.	Cl. of St.	Plate No.
		1	2	3	4	5	6				
26FC/1855	B.00107A	<b>BRACKET</b> , forward, bottom, accumulator mounting						2	—	C.	J.2
28D/12516	A25/11C	Attaching parts for B.00107A, Bracket :—									
28M/13591	A24/CP	Bolt, 2 BA						2	—	C.	
26BY/3165	DHS.33 Mk. 1	Nut, 2 BA						2	—	C.	
		Washer						4	—	C.	
26FC/1856	B.00108A	<b>BRACKET</b> , forward, top, accumulator mounting						2	—	C.	J.2
26BY/13445	DHS.12 Mk. 16	Attaching parts for B.00108A Bracket :—									
28W/12252	SP.13/C	Bolt, 2 BA						2	—	C.	
		Washer						2	—	C.	
594	12 FS 25A	<b>BRACKET</b> , hinge, centre and rear, for gun bay doors						4	MR	C.	
595	12 FS 31A	<b>BRACKET</b> , hinge, forward, for gun bay doors						2	MR	C.	J.7
		Attaching parts for 12 FS 25A and 12 FS 31A Brackets :—									
28D/12864	A26/10C	Bolt, 2 BA						2	MR	C.	
28D/13168	A26/10E	Bolt, 1/2" BSF						2	MR	C.	
28M/13591	A24/CP	Nut, 2 BA						2	MR	C.	
28M/13271	A24/EP	Nut, 1/2" BSF						2	MR	C.	
	12 N 1611	<b>BRACKET</b> , mounting, floodlight on port side, bulk-head No. 2						1	—		J.5
	12 F 1071	<b>BRACKET</b> , mounting, fire warning lamp, on accelerometer mounting bracket						1	—		
		Attaching parts for 12 F 1071 Bracket :—									
28M/10274	AGS.2001/B/4	Nut, 4 BA						2	—	C.	
28S/2073	A43/B16	Screw, 4 BA						2	—	C.	
28W/12306	SP.15/B	Washer						2	—	C.	
2900	12 FS 953A	<b>BRACKET</b> , mounting, for downward identification lamp						1	—	C.	J.4
26FC/4604	B.001847	<b>BRACKET</b> , mounting, for E.2A compass						1	—	C.	J.8
		(Pre Mod. Ven. 273)									
		Attaching parts for B.901847, Bracket :—									
28M/10275	AGS.2001/C/4	Nut, 2 BA						3	—	C.	
28S/2132	A45/C20	Screw, 2 BA						3	—	C.	
	12 F 2197	<b>BRACKET</b> , mounting E.2A compass (Mod. Ven. 273)						1	—		
		(Pre Mod. Ven. 328)									
		Attaching parts for 12 F 2197, Bracket :—									
28M/10275	AGS.2001/C/4	Nut, 2 BA						3	—	C.	
	12 F 1327	<b>BRACKET</b> , mounting E.2A Compass (Mod. Ven. 328)						1	—		
		Attaching parts for 12 F 1327 Bracket :—									
28M/10275	AGS.2001/C/4	Nut, 2 BA						3	—	C.	
	12 F 985ND	Piece, packing (Mod. Ven. 751)						3	—		
	12 F 1905ND	Piece, packing (Mod. Ven. 751)						3	—		
28S/14785	A44/C44	Screw, 2 BA						3	—	C.	
28W/12252	SP.13/C	Washer, 2 BA						3	—	C.	
	12 F 2159A/ND	<b>BRACKET</b> , mounting accelerometer, E.2A Compass and emergency light (Mod. Ven. 751)						1	—		
	12 F 2107	<b>BRACKET</b> , emergency light						1	—		
		Attaching parts for 12 F 2107 Bracket :—									
28M/10288	12 F 1277ND	Bolt, special (Make from 28D/12531—A25/3C)						3	—		
28W/12252	AGS.2001/C/1	Nut, 2 BA						1	—	C.	
		Washer						3	—	C.	
	12 F 2040	<b>BRACKET</b> , clip (Mod. Ven. 751)						1	—		
	12 F 2161	<b>BRACKET</b> , mounting E.2A Compass and accelerometer (Mod. Ven. 751)						1	—		
8122	12 M 277A/ND	<b>BRACKET</b> , mounting, for safety catch, wing tip tank jettison lever, complete						1	MR	C.	J.5
1688	12 M 271	<b>BRACKET</b> , mounting						1	—	C.	J.5
1144	12 F 811A	<b>CATCH</b> , safety						1	—	C.	J.5
		Attaching parts for 12 M 277A/ND Bracket :—									
28D/11564	AS.1246/1C	Bolt, 2 BA						4	—	C.	
28L/11069	AGS.2035/C	Lockwasher						4	—	C.	
26FC/1857	B.00111A	<b>BRACKET</b> , mounting, rear L.H., for accumulator						1	—	C.	J.2
26FC/1858	B.00112A	<b>BRACKET</b> , mounting, rear R.H., for accumulator						1	—	C.	J.2
		Attaching parts for B.00111A and B.00112A Brackets :—									
28D/13337	A.26/7C	Bolt, 2 BA						1	—	C.	
28D/13055	A26/12C	Bolt, 2 BA						2	—	C.	
28M/13591	A24/CP	Nut, 2 BA						3	—	C.	
26BY/3165	DHS.33 Mk. 1	Washer, 2 BA, shrinkage						6	—	C.	
	A.001003	<b>BRACKET</b> , oxygen bottles strap anchor, on ammunition boxes, 16 SWG, L.72						2	—		J.6
		Attaching parts for A.001003 Bracket :—									
28D/12568	A25/22C	Bolt, 2 BA						1	—	C.	

FUSELAGE COMPLETE

Ref. No.	Part No.	Nomenclature						No Off.	M.R.	Cl. of St.	Place No.
		1	2	3	4	5	6				
	A.002747	<b>BRACKET</b> , reinforcing, L.H. canopy rail to bulkhead No. 2						1	—		J.5
	A.002748	<b>BRACKET</b> , reinforcing, R.H. canopy rail to bulkhead No. 2						1	—		J.5
		Attaching parts for A.002747 and A.002748 Brackets :—									
28D/14648	A26/14E	Bolt, 1/4" BSF ...						2	—	C.	
28G/3828	AGS.798/K	Eyebolt, 1/4" BSF ...						1	—	C.	
28M/13271	A.24/EP	Nut, 1/4" BSF ...						2	—	C.	
28M/10299	AGS.2001/E/2	Nut, 1/4" BSF ...						1	—	C.	
	A.002749	Plate, washer ...						1	—		
28W/3090	AGS.163/D	Washer ...						2	—	C.	
28W/13388	SP.13/E	Washer ...						3	—	C.	
	A/MBEU/115V	<b>BRACKET</b> , static line container on cockpit floor, Martin Baker						1	—		
		Attaching parts for A/MBEU/115V, Bracket :—									
28D/11564	AS.1246/1C	Bolt, 2 BA ...						4	—	C.	
9030	12 FS 65A	<b>BRACKET</b> , support, bulkhead No. 3 to fuselage side, L.H.						1	MR	C.	J.2
9031	12 FS 66A	<b>BRACKET</b> , support, bulkhead No. 3 to fuselage side, R.H.						1	MR	C.	J.2
		Attaching parts for 12 FS 65A and 12 FS 66A, Brackets :—									
28D/13163	A26/23E	Bolt, 1/4" BSF ...						3	MR	C.	
28D/12741	AS.2920/20E	Bolt, 1/4" BSF ...						6	MR	C.	
28M/13271	A.24/EP	Nut, 1/4" BSF ...						9	MR	C.	
	12 FS 717ND	Packing, 3"10 long, L.72 ...						1	MR		J.2
	DHS.191	Washer, 1/4" BSF, cup ...						6	MR		
28W/3090	AGS.163/D	Washer, 1/4" BSF, double spring ...						17	MR	C.	
28W/3099	AGS.162/D	Washer, spring, single ...						1	MR	C.	
26FC/5372	G.001847A	<b>BRACKET</b> , mounting, for micro switch at nose wheel leg						1	—	C.	J.3
		Attaching parts for G.001847A, Bracket :—									
28D/12512	A.25/1C	Bolt, 2 BA ...						2	—	C.	
28M/10288	AGS.2001/C/1	Nut, 2 BA ...						2	—	C.	
28W/12252	SP.13/C	Washer ...						2	—	C.	
26FC/4359	A.005291	<b>BRACKET</b> , stowage, for gyro-gunsight recorder ...						1	—	C.	J.1
8116	12 FS 691A	<b>BRACKET</b> , support, centre hinge, gun bay door, front L.H.						1	MR	C.	J.7
8118	12 FS 695A	<b>BRACKET</b> , support, centre hinge, gun bay door, front R.H.						1	MR	C.	J.7
8117	12 FS 693A	<b>BRACKET</b> , support, centre hinge, gun bay door, rear, L.H.						1	MR	C.	J.7
8119	12 FS 697A	<b>BRACKET</b> , support, centre hinge, gun bay door, rear R.H.						1	MR	C.	J.7
		Attaching parts for 12 FS 691A, 12 FS 695A, 12 FS 693A and 12 FS 697A, Brackets (per pair) :—									
28D/12864	A26/10C	Bolt, 2 BA ...						2	MR	C.	
28D/13168	A26/10E	Bolt, 1/4" BSF ...						2	MR	C.	
28D/12737	AS.2920/8E	Bolt, 1/4" BSF ...						2	MR	C.	
28M/12591	A24/CP	Nut, 2 BA ...						2	MR	C.	
28M/13271	A24/EP	Nut, 1/4" BSF ...						4	MR	C.	
26BY/13054	DHS.69/DD	Shim, 1/4" BSF ...						QR	MR	C.	
	DHS.191	Washer, 1/4" BSF, cup ...						2	MR		

## FUSELAGE COMPLETE

Ref. No.	Part No.	Nomenclature						No. of Off	M.R.	Cl. of St.	Plate No.
		1	2	3	4	5	6				
26FC/3049	B.00468A	<b>BRACKET</b> , support for radio receiver mounting on bulkhead No. 1						2	—	C.	J.3
		Attaching parts for B.00468A Bracket :—									
28S/12514	A25/7C	Bolt	2	BA	...	...	2	—	C.		
28M/12929	A27/CP	Nut	2	BA	...	...	2	—	C.		
28W/12296	SP.15/C	Washer	...	...	...	...	2	—	C.		
	12 M 339	<b>BRACKET</b> , support for conduit clamp under ammunition floor and cockpit floor						2	MR		J.5
		Attaching parts for 12 M 339 Bracket :—									
28D/12512	A25/1C	Bolt	2	BA	...	...	1	—	C.		
28L/11069	AGS.2035/C	Lockwasher	...	...	...	...	1	—	C.		
2181	12 FS 47A	<b>BRACKET</b> , support forward hinge gun bay door front L.H. and rear R.H.						2	MR	C.	J.7
2182	12 FS 48A	<b>BRACKET</b> , support forward hinge gun bay door front R.H. and rear L.H.						2	MR	C.	J.7
		Attaching parts for 12 FS 47A and 12 FS 48A Brackets per pair) :—									
28D/12864	A26/10C	Bolt	2	BA	...	...	3	MR	C.		
28D/13168	A26/10E	Bolt	$\frac{1}{4}$ "	BSF	...	...	2	MR	C.		
28D/12737	AS.2920/8E	Bolt	$\frac{1}{4}$ "	BSF	...	...	2	MR	C.		
28M/13591	A24/CP	Nut	2	BA	...	...	3	MR	C.		
28M/13271	A24/EP	Nut	$\frac{1}{4}$ "	BSF	...	...	4	MR	C.		
	DHS.191	Washer	$\frac{1}{4}$ "	BSF	cup	...	2	MR			
739	12 F 541A	<b>BRACKET</b> , support, fuselage tank strap						2	MR	C.	J.6
		Attaching parts for 12 F 541A Bracket :—									
28D/13166	A26/21E	Bolt	$\frac{1}{4}$ "	BSF	...	...	2	MR	C.		
28M/10299	AGS.2001/E/2	Nut	$\frac{1}{4}$ "	BSF	...	...	2	MR	C.		
26BY/2856	DHS.33 Mk. 2	Washer	$\frac{1}{4}$ "	BSF	shrinkage	...	4	MR	C.		
8113	12 FS 59A	<b>BRACKET</b> , support, rear hinge, gun bay door, front L.H. and rear R.H.						2	MR	C.	J.7
8114	12 FS 60A	<b>BRACKET</b> , support, rear hinge, gun bay door, front R.H. and rear L.H.						2	MR	C.	J.3
		Attaching parts for 12 FS 59A and 12 FS 60A, Brackets (per pair) :—									
28D/12864	A26/10C	Bolt	2	BA	...	...	2	MR	C.		
28D/13168	A26/10E	Bolt	$\frac{1}{4}$ "	BSF	...	...	2	MR	C.		
28D/12736	AS.2920/20C	Bolt	2	BA	...	...	2	MR	C.		
28D/12737	AS.2920/8E	Bolt	$\frac{1}{4}$ "	BSF	...	...	2	MR	C.		
28M/13591	A24/CP	Nut	2	BA	...	...	4	MR	C.		
28M/13271	A24/EP	Nut	$\frac{1}{4}$ "	BSF	...	...	4	MR	C.		
26FC/5725	DHS.190	Washer	2	BA	cup	...	2	MR	C.		
	DHS.191	Washer	$\frac{1}{4}$ "	BSF	cup	...	2	MR			
	A.0021A/1	<b>BULKHEAD, No. 1</b> , armour plate						1	MR		J.1
		Attaching parts for A.0021A/1 Bulkhead :—									
28D/13041	A26/17C	Bolt	2	BA	...	...	8	MR	C.		
28D/13160	A26/19C	Bolt	2	BA	...	...	16	MR	C.		
28D/13076	A26/21C	Bolt	2	BA	...	...	8	MR	C.		
28M/13591	A24/CP	Nut	2	BA	...	...	32	MR	C.		
28W/12439	SP.19/C	Washer	...	...	...	...	32	MR	C.		
5878	DHS.187 Mk. 1	Washer	2	BA	shrinkage	...	64	MR	C.		

FUSELAGE COMPLETE

Ref. No.	Part No.	Nomenclature						No. Off	M.R.	Cl. of St.	Plate No.
		1	2	3	4	5	6				
	A.007287ND	<b>CABLE</b> , check, for pilots' step (Make from Bowden cable, Part No. P7/62)						1	—		
	—	<b>CANOPY</b> , cockpit (12 FC 7) (See Separate Unit)						1	—		
27H/2768	†	<b>CASE</b> , for pilot's notes ... ..						1	—	C.	
1144	12 F 811A	<b>CATCH</b> , safety for bomb and drop tank jettison lever						1	—	C.	
27FC/1954	A.001465/1	<b>CHANNEL</b> , reinforcing, at ammunition loading door opening, L.H.						1	—	C.	J.6
26FC/1955	A.001466/1	<b>CHANNEL</b> , reinforcing, at ammunition loading door opening, R.H.						1	—	C.	J.6
26FC/2729	A.001839	<b>STRIP</b> , attachment, for rubber seal on rear edge of L.H. door						1	—	C.	J.6
26FC/2730	A.001840	<b>STRIP</b> , attachment, for rubber seal on rear edge of R.H. door						1	—	C.	J.6
26FC/1899	A.001474ND	<b>STRIP</b> , sealing ... ..						1	—	C.	J.6
26FC/3752	A.002499A	<b>STRUT</b> , stay ... ..						1	—	C.	J.6
		Attaching parts for A.002499A, Strut :—									
28D/12612	A25/1C	Bolt, 2 BA ... ..						1	—	C.	
28L/13124	A27/CT	Locknut, 2 BA ... ..						1	—	C.	
1301	12 A 325A	<b>CLAMP</b> , cannon heating pipe support ... ..						1	—	C.	J.7
28D/12629	A25/8C	<b>BOLT</b> , 2 BA ... ..						2	—	C.	
28E/14143	AS.487/8	<b>CLIP</b> , saddle ... ..						2	—	C.	
28M/10288	AGS.2001/C/1	<b>NUT</b> , 2 BA ... ..						2	—	C.	
		Attaching parts for 12 A 325A Clamp :—									
28D/12514	A25/7C	Bolt, 2 BA ... ..						2	—	C.	
28M/10288	AGS.2001/C/1	Nut, 2 BA ... ..						2	—	C.	
	R.00246	<b>CLIP</b> , cannon heating pipe on fuselage side, 20 SWG, S.84 (Make from Ref. No. 30A/2159)						1	—		J.7
		Attaching parts for R.00246 Clip :—									
28D/11564	AS.1246/1C	Bolt, 2 BA ... ..						1	—	C.	
28L/11069	AGS.2035/C	Lockwasher ... ..						1	—	C.	
7100	12 A 593ND	<b>CLIP</b> , cannon heating pipe on bulkhead No. 2, 18 SWG, L.72						2	MR	C.	J.7
		Attaching parts for 12 A 593ND Clip :—									
28D/12631	A25/23C	Bolt, 2 BA ... ..						2	—	C.	
28M/10288	AGS.2001/C/1	Nut, 2 BA ... ..						2	—	C.	
26BY/3165	DHS.33/1	Washer, shrinkage ... ..						4	—	C.	
28W/12296	SP.15/C	Washer ... ..						2	—	C.	
28E/8182	AGS.605/0	<b>CLIP</b> , for demister pipes (Mod. Ven. 633) ... ..						2	—	C.	
10104	12 V 1065A	<b>CLIP</b> , mounting demister pipe, Port ... ..						1	—	C.	
10105	12 V 1075A	<b>CLIP</b> , mounting demister pipe, Starboard (Mod. Ven. 633)						1	—	C.	
		Attaching parts for 12 V 1065A and 12 V 1075A Clips :—									
28D/12512	A25/1C	Bolt, 2 BA ... ..						2	—	C.	
28M/10328	AGS.2002/C/1	Nut, 2 BA ... ..						2	—	C.	
	12 N 1615	<b>CLIP</b> , mounting, for forward floodlight, cockpit side, Port						1	—		
		Attaching parts for 12 N 1615 Clip :—									
28M/10287	AGS.2001/B/1	Nut, 4 BA ... ..						1	—	C.	
28S/14005	A32/B14	Screw, 4 BA ... ..						1	—	C.	
28E/10027	AS.2295/1	<b>CLIP</b> , spring, for cable, on gyro gunsight recorder mounting block						1	—	C.	
28E/10042	AS.2294/5	<b>CLIP</b> , spring, for crowbar stowage on bulkhead No. 2						2	—	C.	
6B/405	†	<b>COMPASS</b> , E.2A ... ..						1	—	A.	
		Attaching parts for A.M. Ref. No. 6B/405 Compass :—									
28M/10274	AGS.2001/B/4	Nut, 3 BA ... ..						2	—	C.	
28S/2413	A44/B16	Screw, 4 BA ... ..						2	—	C.	

FUSELAGE COMPLETE

Ref. No.	Part No.	Nomenclature						No. Off	M.R.	Cl. of St.	Plate No.
		1	2	3	4	5	6				
27K/550	DS.56/3	<b>CONDUIT</b> , Teleflex No. 3 drop tank and bomb jettison control						QR	—	C.	
27K/973	B.33350	<b>CONNECOTR</b> , conduit bomb jettison control ...						2	—	C.	
32C/50	†	<b>CONTAINER</b> , static line on cockpit floor ...						1	—	C.	
1666	12 F 661	<b>CORD</b> , elastic securing First Aid equipment bag ...						QR	—	C.	
	12 F 1603A	<b>DISH</b> , support between ammunition boxes for oxygen bottles						2	—	C.	J.6
	12 F 1605A	<b>DOOR</b> , ammunition L.H. ...						1	—		J.6
28E/10025	AS.2295/3	<b>DOOR</b> , ammunition R.H. ...						1	—		J.6
	B.001107A	<b>CLIP</b> , spring for stay strut ...						1	—	C.	
1008	12 F 637A	<b>CORD</b> , elastic water bottle stowage L.H. door						1	—		
		<b>HANDLE</b> , lock ...						2	—	C.	J.6
28L/12931	A27/ET	Attaching parts for 12 F 637A Handle :—									
	A.00331	Locknut 1/4" BSF ...						1	—	C.	J.6
28W/12253	SP.13/E	Shim ...						1	—	C.	
		Washer ...						1	—	C.	J.6
	A.002769ND	<b>HINGE</b> ...						1	—		J.6
		Attaching parts for A.002769ND Hinge :—									
28D/8300	AS.1242/1B	Bolt 4 BA ...						7	—	C.	
28M/13086	A27/BP	Nut 4 BA ...						7	—	C.	
	1602	<b>LOCK</b> ...						2	—	C.	
	1448	<b>SPRING</b> ...						1	—	C.	JC.6
		Attaching parts for 12 F 897A Lock :—									
28D/8312	AS.1242/8C	Bolt 2 BA ...						1	—	C.	
28D/10168	AS.1242/11C	Bolt 2 BA ...						2	—	C.	
28M/12929	A27/CP	Nut 2 BA ...						3	—	C.	
	691	<b>PACKING</b> , for lock 10 SWG L.72 ...						2	—	C.	J.6
	13 FS 2993ND	<b>PLATE</b> , corner for attachment of rubber seal 18 SWG L.92						4	—		
26FC/3008	A.002605	<b>STRIP</b> , attachment for rubber seal on bottom edge of door						1	—	C.	J.6
26FC/1895	A.001385	<b>STRIP</b> , attachment for rubber seal on front edge of L.H. door						1	—	C.	J.6
26FC/1900	A.001836	<b>STRIP</b> , attachment for rubber seal on front edge of R.H. door						1	—	C.	J.6
		Attaching parts for 12 F 1603A and 12 F 1605A Doors :—									
28D/12733	AS.2920/6C	Bolt 2 BA ...						6	—	C.	
28M/13591	A24/CP	Nut 2 BA ...						6	—	C.	
26FC/3551	B.00156A/2	<b>DOOR</b> , front armour bulkhead No. 1 ...						1	—	C.	J.3
26FC/3555	B.001077A	<b>CABLE</b> , check ...						1	—	C.	
26FC/1905	R.98361	<b>CAP</b> , blanking ...						1	—	C.	
26FC/3510	B.00160	<b>CLAMP</b> , locking ...						2	—	C.	J.3
		Attaching parts for B.92160 Clamp :—									
28D/12813	A25/26E	Bolt 1/4" BSF ...						1	—	C.	
28D/8328	AS.1242/7E	Bolt 1/4" BSF ...						1	—	C.	
28M/12928	A27/EP	Nut 1/2" BSF ...						2	—	C.	
28W/12253	SP.13/E	Washer ...						1	—	C.	
	B.001050A	<b>COVER</b> , for ballast weight ...						1	—		J.3
27FC/1906	R.98360	<b>FLANGE</b> , for blanking cap ...						1	—	C.	J.3
		Attaching parts for R.98360 Flange :—									
28D/12514	A25/7C	Bolt 2 BA ...						1	—	C.	
28D/12714	A25/29C	Bolt 2 BA ...						7	—	C.	
28M/12929	A27/CP	Nut 2 BA ...						8	—	C.	
28W/12252	SP.13/C	Washer ...						8	—	C.	

FUSELAGE COMPLETE

Ref. No.	Part No.	Nomenclature						No. Off	M.R.	Cl. of St.	Plate No.
		1	2	3	4	5	6				
26FC/1907	R.00109							1	—	C.	J.3
26FC/3511	B.00165							2	—	C.	
28D/12814	A25/29E							1	—	C.	
28D/8328	AS.1242/7E							1	—	C.	
28L/12931	A27/ET							1	—	C.	
28M/12928	A27/EP							1	—	C.	
28W/12253	SP.13/E							1	—	C.	
	B.001047ND							2	—		J.3
26FC/1908	B.00159							1	—	C.	J.3
26FC/4655	R.98362							1	—	C.	J.3
26FC/3554	B.001049							1	—	C.	J.3
28P/1040	SP.4Y/D.18							2	—	C.	
28P/12462	SP.9/C8							2	—	C.	
6669	12 FS 905A/1							1	—	A.	J.1
9729	12 FS 205A/8							1	—	A.	J.1
2895	12 EM 195							2	MR	C.	
28M/13375	A27/GP							1	—	C.	
1021	12 EM 173							2	MR	C.	J.2
28W/12254	SP.13/G							1	MR	C.	
1022	12 EM 175							1	MR	C.	J.2
565	12 EM 133							1	—	C.	J.2
1904	12 EM 185							1	MR	C.	J.2
1905	12 EM 187							1	MR	C.	J.2
1906	12 EM 189							1	MR	C.	J.2
2399	12 EM 199							2	MR	C.	
2358	12 EM 197							2	MR	C.	
28M/13606	A24/PC							1	—	C.	
28P/12463	SP.9/E10							1	MR	C.	
570	12 EM 161							1	MR	C.	J.2
1023	12 EM 177							1	MR	C.	J.2
1907	12 EM 191							1	MR	C.	J.2
566	12 EM 137							1	MR	C.	J.2
1908	12 EM 93							1	MR	C.	
569	12 EM 159							1	MR	C.	J.2
28W/14305	SP.14/P							QR	—	C.	
28G/3816	AGS.797/1							2	—	C.	
26BY/14110	DHS.84 Mk. 4							4	—	C.	
26FC/5400	A.00891A/2							1	—	C.	
1153	12 F 723A							1	—	C.	
7201	12 F 485A/3							1	—	B.	
26FC/838	A.001923							1	MR	C.	
26FC/840	A.00757A							2	—	C.	
28D/12512	A25/1C							2	—	C.	
28M/12929	A27/CP							2	—	C.	

FUSELAGE COMPLETE

Ref. No.	Part No.	Nomenclature						No. Off	M,R.	Cl. of St.	Plate No.
		1	2	3	4	5	6				
26FC/839	A.001894	<b>BRACKET</b> , front, lower ... ..						1	MR	C.	J.3
26FC/841	A.001899	<b>BRACKET</b> , peg support, L.H. ... ..						1	MR	C.	J.3
26FC/842	A.001900	<b>BRACKET</b> , peg support, R.H. ... ..						1	MR	C.	J.3
26FC/843	A.001901	<b>BRACKET</b> , stiffening, nose wheel fairing front attachment bracket, L.H.						1	MR	C.	J.3
26FC/844	A.001902	<b>BRACKET</b> , stiffening, nose wheel fairing front attachment, bracket R.H.						1	MR	C.	J.3
26FC/847	A.001903	<b>CHANNEL</b> , stiffening, centre, L.H. ... ..						1	MR	C.	J.3
26FC/848	A.001904	<b>CHANNEL</b> , stiffening, centre, R.H. ... ..						1	MR	C.	J.3
26FC/845	A.001907	<b>CHANNEL</b> , stiffening, front, L.H. ... ..						1	MR	C.	J.3
26FC/846	A.001908	<b>CHANNEL</b> , stiffening, front, R.H....						1	MR	C.	J.3
26FC/849	A.001895	<b>CHANNEL</b> , top former, L.H. ... ..						1	MR	C.	J.3
26FC/850	A.001896	<b>CHANNEL</b> , top former, R.H. ... ..						1	MR	C.	J.3
	R.001351A	<b>DUCT</b> , air inlet ... ..						1	MR		J.3
	A.001786A/ND	<b>FRAME</b> , handhole cover plate, on starboard side						1	MR		J.3
26FC/851	A.001269ND	<b>FRAME</b> ... ..						1	MR	C.	J.3
28M/10228	AGS.2009/B/1	<b>NUT</b> , 4 BA ... ..						8	—	C.	
26FC/853	A.00917A	<b>PEG</b> , locating detachable top nose fairing						2	—	C.	J.3
		Attaching parts for A.00917A, Peg :—									
28D/12512	A25/1C	Bolt, 2 BA ... ..						2	—	C.	
28M/10288	AGS.2001/C/1	Nut, 2 BA ... ..						4	—	C.	
26FC/855	A.001270ND	<b>PLATE</b> , handhole cover, on starboard side						1	—	C.	J.3
		Attaching parts for A.001270ND, Plate :—									
28D/8300	AS.1242/1B	Bolt, 4 BA ... ..						8	—	C.	
26FC/854	A.001922	<b>PLATE</b> , lap jointing, top channels ... ..						1	MR	C.	J.3
1093	12 F 651A	<b>PLUNGER</b> , spring, for locking detachable top nose fairing						1	—	C.	J.3
1097	12 F 647	<b>CAP</b> , for housing ... ..						1	—	C.	J.3
1154	12 F 643	<b>HOUSING</b> , for plunger ... ..						1	—	C.	
1096	12 F 645	<b>PLUNGER</b> ... ..						1	—	C.	J.3
	12 F 653ND	<b>PIN</b> , securing plunger, 1/8" dia. M/S S.1						1	—		J.3
1095	12 F 649	<b>SPRING</b> ... ..						1	—	C.	J.3
		Attaching parts for 12 F 651A, Plunger :—									
28M/10288	AGS.2001/C/1	Nut, 2 BA ... ..						3	—	C.	
28S/2820	A33/C20	Screw, 2 BA ... ..						3	—	C.	
26FC/861	A.001897	<b>STIFFENER</b> , bottom edge, L.H. ... ..						1	MR	C.	J.3
26FC/862	A.001898	<b>STIFFENER</b> , bottom edge, R.H. ... ..						1	MR	C.	J.3
26FC/859	A.001905	<b>STIFFENER</b> , rear edge, L.H. ... ..						1	MR	C.	J.3
26FC/860	A.001906	<b>STIFFENER</b> , rear edge, R.H. ... ..						1	MR	C.	J.3
		Attaching parts for 12 F 485A/3, Fairing :—									
28S/2814	A33/C16	Screw, 2 BA ... ..						18	—	C.	
28S/2820	A33/C20	Screw, 2 BA ... ..						14	—	C.	

FUSELAGE COMPLETE

Ref. No.	Part No.	Nomenclature						No. Off.	M.R.	Cl. of St.	Plate No.
		1	2	3	4	5	6				
1867	12 FS 883A	<b>FAIRING</b> , nose wheel, in cockpit ... ..						1	MR	C.	J.4
	12 FS 881A	<b>BRACKET</b> , differential unit mounting ... ..						1	—	—	J.4
26FC/1915	G.00317A	<b>BRACKET</b> , instrument panel mounting, L.H. ...						1	—	C.	J.4
26FC/1916	G.00318A	<b>BRACKET</b> , instrument panel mounting, R.H. ...						1	—	C.	L.4
1868	12 F 977	<b>BRACKET</b> , machmeter warning device ... ..						1	—	C.	J.4
26FC/3036	Q.00891A	<b>PLATE</b> , bolt, clamp block mounting ... ..						1	—	C.	J.4
26FC/1912	A.00799	<b>FAIRLEAD</b> , for elevator cable, on bulkhead No. 3						1	—	C.	J.2
26BY/4148	DHS.103 Mk. 1	<b>FERRULE</b> , 4 BA ... ..						QR	—	C.	
26BY/6964	DHS.103 Mk. 2	<b>FERRULE</b> , 2 BA ... ..						QR	—	C.	
28H/5564	AGS.897/B	<b>FERRULE</b> , for elastic cord securing "First Aid" equipment bag						4	—	C.	
26FC/10328	DHS.98	<b>FERRULE</b> , for use with woodscrews ... ..						5	—	C.	
	12 F 1173A	<b>FRAME</b> , accumulator mounting support, L.H. ...						1	—	—	J.2
	12 F 1174A	<b>FRAME</b> , accumulator mounting support, R.H. ...						1	—	—	J.2
	12 F 1197	<b>LEVER</b> , locking ... ..						1	—	—	J.2
28P/868	SP.4Y/D10	<b>PIN</b> , shackle ... ..						1	—	C.	
28P/12462	SP.9/C8	<b>PIN</b> , split ... ..						1	—	C.	
26FC/1922	B.00142	<b>SPRING</b> , for locking lever ... ..						1	—	C.	J.2
28W/12253	SP.13/E	<b>WASHER</b> ... ..						1	—	C.	
		Attaching parts for 12 F 1173A and 12 F 1174A, Frames :—									
28D/12629	A25/8C	Bolt, 2 BA ... ..						1	—	C.	
28D/12516	A25/11C	Bolt, 2 BA ... ..						1	—	C.	
28M/13121	A27/CS	Nut, 2 BA ... ..						2	—	C.	
28P/12462	SP.9/C8	Pin, split ... ..						2	—	C.	
	B.00234ND	Tube, distance, $\frac{1}{2}$ " o/d x 22 SWG x 0.83 long, T.35 (Make from Ref. No. 30A/1923)						1	—	—	J.2
	B.00235ND	Tube, distance, $\frac{1}{2}$ " o/d x 22 SWG x 1.1 long, T.35 (Make from Ref. No. 30A/1923)						1	—	—	J.2
28W/12252	SP.13/C	Washer ... ..						2	—	C.	
5L/X951230	†	<b>FILAMENT</b> , for fire warning lamp 24 Volt, clear ...						1	—	B.	
26FC/817	A.001308A	<b>FRAME</b> , pilot's access step cover plate ... ..						1	—	C.	J.1
		Attaching parts for A.001308A, Frame :—									
28D/12648	AS.2920/7C	Bolt, 2 BA ... ..						2	—	C.	
28D/12734	AS.2920/8C	Bolt, 2 BA ... ..						2	—	C.	
28M/13591	A24/CP	Nut, 2 BA ... ..						4	—	C.	
26FC/823	A.001314	<b>GASKET</b> , sealing, for pilot's access step outer casing						1	—	C.	
2901	12 FS 961A	<b>GUARD</b> , for downward identification lamp ... ..						1	—	C.	J.4
26FC/7157	B.00166	<b>HINGE</b> , for door in front armour bulkhead No. 1						2	—	C.	J.3
		Attaching parts for B.00166, Hinge :—									
28D/12543	A25/6E	Bolt, $\frac{1}{2}$ " BSF ... ..						1	—	C.	
28D/9435	AS.1242/8E	Bolt, $\frac{1}{2}$ " BSF ... ..						1	—	C.	
28M/12928	A27/EP	Nut, $\frac{1}{2}$ " BSF ... ..						1	—	C.	
28M/10290	AGS.2001/E/1	Nut, $\frac{1}{2}$ " BSF ... ..						1	—	C.	
	A.001814ND	Shim, under hinge, 1.15 wide x 20 SWG x 2.0 long, L.72						1	—	—	J.3
26FC/4078	B.002595A	<b>HOLDER</b> , for pilot's notes ... ..						1	—	C.	J.1
458	12 FS 375A/ND	<b>HOUSING</b> , nose wheel ... ..						1	MR	B.	J.4
26FC/1853	A.001363	<b>BRACKET</b> , nose wheel door front hinge ... ..						1	MR	C.	J.4
26FC/1848	A.00633	<b>BRACKET</b> , nose wheel door link guide ... ..						1	—	C.	J.4
		Attaching parts for A.00633, Bracket :—									
28D/12513	A25/2C	Bolt, 2 BA ... ..						2	—	C.	
28M/12929	A27/CP	Nut, 2 BA ... ..						2	—	C.	

FUSELAGE COMPLETE

Ref. No.	Part No.	Nomenclature						No. Off	M.R.	Cl. of St.	Plate No.
		1	2	3	4	5	6				
26FC/1852	A.001124A							1	MR	C.	J.4
26FC/1854	A.001416							1	MR	C.	J.4
26FC/1889	A.00635							1	MR	C.	J.4
26FC/1890	A.00636							1	MR	C.	J.4
26FC/1888	A.00634							1	MR	C.	J.4
26FC/4322	A.00648A/1							1	MR	C.	J.4
8319	12 FS 899A							1	MR	C.	J.4
8320	12 FS 900A							1	MR	C.	J.4
27FP/342	S6/250 DZUS							2	—	C.	
26FC/5855	A.005197A							1	—	C.	
28D/8342	AS.1248/2C							8	—	C.	
27FP/342	S6/250 DZUS							16	—	C.	
27FP/353	No. 1-90 DZUS							2	—	C.	
28D/12566	A.25/6C							5	MR	C.	
28D/12629	A25/8C							2	MR	C.	
28D/12534	A25/9C							4	MR	C.	
28D/12515	A25/10C							2	MR	C.	
28D/12516	A25/11C							28	MR	C.	
28D/12535	A25/12C							3	MR	C.	
28D/12537	A25/14C							5	MR	C.	
28D/12538	A25/15C							6	MR	C.	
28D/13105	A25/26C							2	MR	C.	
28D/12632	A25/30C							2	MR	C.	
28M/12929	A27/CP							57	MR	C.	
28M/10288	AGS.2001/C/1							2	MR	C.	
26BY/5871	DHS.34/C							21	MR	C.	
28W/12588	SP.18/C							2	MR	C.	
26BY/3165	DHS.33 Mk. 1							92	MR	C.	
10103	12 V 1058							1	—	C.	
10102	12 V 1057							1	—	C.	
28D/8301	AS.1242/2B							2	—	C.	
28M/13086	A27/BP							2	—	C.	
28W/12252	SP.13/C							2	—	C.	

FUSELAGE COMPLETE

Ref. No.	Part No.	Nomenclature						No. Off.	M.R.	Cl. of St.	Plate No.
		1	2	3	4	5	6				
	12 F 1309	<b>LABEL</b> , "Aileron Trim Cut-out," fuselage wall, port						1	—	—	J.8
	B.00475	<b>LABEL</b> , "Fire Warning" ... ..						1	—	—	J.6
	S.00865	<b>LABEL</b> , "Left Hand Belt Tank Capacity 140 Rounds," on ammunition box						2	—	—	J.6
	S.00867	<b>LABEL</b> , "Right Hand Belt Tank Capacity 140 Rounds," on ammunition box						2	—	—	J.6
	12 F 747	<b>LABEL</b> , undercarriage and flap speed warning ...						1	—	—	J.8
	12 F 1073	<b>LAMP</b> , fire warning, mounted on E.2.A Compass, (Make from 5CX/1069)						1	—	—	
10AF/530	†	<b>METER</b> , range and heading indicator ... ..						1	—	A.	
		Attaching parts for AM. Ref. No. 10AF/530, Meter :—									P.1
28S/13814	A43/B14	Screw, 4 BA ... ..						4	—	C.	
28W/12676	SP.22/B	Washer ... ..						4	—	C.	
10AJ/143	†	<b>MOUNTING</b> , anti vibration, on nose wheel housing, for mounting tray for TR 3708, Equipflex, type 952						4	—	B.	
		Attaching parts for 10AJ/143, Mounting :—									
28M/10287	AGS.2001/B/1	Nut, 4 BA ... ..						8	—	C.	
28S/2761	A31/B12	Screw, 4 BA ... ..						8	—	C.	
1799	12 FS 815A	<b>MOUNTING</b> , complete with anti-vibration ring for downward identification lamp						1	—	C.	J.8
1266	12 P 331A	<b>MOUNTING</b> , for Pacitor power unit ... ..						1	—	C.	
		Attaching parts for 12 P 331A, Mounting :—									
28D/12139	AS.1246/6C	Bolt, 2 BA ... ..						2	—	C.	
28D/11564	AS.1246/1C	Bolt, 2 BA ... ..						2	—	C.	
28L/11069	AGS.2035/C	Lockwasher ... ..						4	—	C.	
	12 UN 213A	<b>MOUNTING</b> , for radio receiver in nose ... ..						1	MR		
		Attaching parts for 12 UN 213A, Mounting :—									
28D/12629	A25/8C	Bolt, 2 BA ... ..						2	—	C.	
28M/10288	AGS.2001/C/1	Nut, 2 BA ... ..						2	—	C.	
	B.00175ND	Tube, distance, 1/4" o/d x 22 SWG x 0.698 long, T.26 (Make from A.M. Ref. No. 30A/965)						2	—		
	12 UN 209A	<b>MUDGUARD</b> , protecting receiver in nose ... ..						1	MR		
		Attaching parts for 12 UN 209A, Mudguard :—									
28D/12629	A25/8C	Bolt, 2 BA ... ..						2	MR	C.	
28D/12544	A25/8E	Bolt, 1/4" BSF ... ..						4	MR	C.	
28M/10288	AGS.2001/C/1	Nut, 2 BA ... ..						2	MR	C.	
	B.00175ND	Tube, distance, 1/4" o/d x 22 SWG x 0.698 long, T.26 (Make from Ref. No. 30A/965)						2	MR	C.	
	B.00174ND	Tube, distance, 1/4" o/d x 22 SWG x 0.695 long, T.26 (Make from Ref. No. 30A/965)						4	MR	C.	
28W/12296	SP.15/C	Washer ... ..						2	MR	C.	
28W/12253	SP.13/E	Washer ... ..						2	MR	C.	
28W/10931	A27/ET	<b>LOCKNUT</b> , 1/4" BSF, for drop tank jettison lever stop bolt						1	—	C.	
28M/12929	A27/CP	<b>NUT</b> , 2 BA, for fireproof bulkhead securing bolts ...						26	—	C.	
28M/803	AGS.120/A	<b>NUT</b> , 1/4" BSF, for armour door catch bulkhead No. 1						2	—	C.	

FUSELAGE COMPLETE

Ref. No.	Part No.	Nomenclature						No. Off	M.R.	Cl. of St.	Plate No.
		1	2	3	4	5	6				
28M/807	AGS.120/E 12 V 641ND	<b>NUT</b> , $\frac{3}{8}$ " BSF wing, accumulator stowage ... ..						4	—	C.	
		<b>PACKING</b> , at clamp block, 1"25 x .75, LFS.21-23 (Mod. Ven. 633)						1	—		
		Attaching parts for 12 V 641ND Packing :—									
28D/8378	AS.1243/8C	Bolt, 2 BA ... ..						1	—	C.	
	A.002637	<b>PACKING</b> , on bulkhead No. 4 ring, at air duct orifice, L.H.						1	MR		J.7
	A.002638	<b>PACKING</b> , on bulkhead No. 4 ring, at air duct orifice, R.H.						1	MR		J.7
	A.002471A	<b>PEG</b> , C.G. datum origin ... ..						1	—		J.1
1660	12 F 733	<b>PIN</b> , attachment, securing ejector seat bottom bracket on guide rail to bracket on bulkhead No. 2						1	—	C.	
		Attaching parts for 12 F 733 Pin :—									
28P/12349	SP.9/C5	Pin, split ... ..						2	—	C.	
28V/12254	SP.13/G	Washer ... ..						2	—	C.	
1094	12 F 655A	<b>PIN</b> , lower locating, on bulkhead No. 1 for detachable nose fairing						2	—	C.	J.3
		Attaching parts for 12 F 655A, Pin :—									
28M/13375	A27/GP	Nut, $\frac{3}{8}$ " BSF ... ..						1	—	C.	
28V/12324	SP.15/G	Washer ... ..						1	—	C.	
26FC/10300	A.00915A	<b>PIN</b> , top locating, on bulkhead No. 1 for detachable nose fairing						1	—	C.	J.3
		Attaching parts for A.00915A Pin :—									
28M/10331	AGS.2002/G/1 B.001014	Nut, $\frac{3}{8}$ " BSF ... ..						1	—	C.	J.3
		Plate, washer, 18 SWG, S.84 (Make from Ref. No. 30A/2162)						1	—		
6060	12 A 605A	<b>PIPE</b> , cannon heating at bulkhead No. 2 ... ..						1	—	C.	J.7
6071	12 A 603	<b>PIPE</b> , cannon heating, joint at fireproof bulkhead to joint at bulkhead No. 2						1	—	C.	J.7

FUSELAGE COMPLETE

Ref. No.	Part No.	Nomenclature						No Off.	M.R.	Cl. of St.	Plate No.
		1	2	3	4	5	6				
26FC/2880	B.00369ND	PLATE, armour, external, bottom of windscreen						1	MR	C.	J.8
26FC/2878	B.00365ND	PLATE, armour, external, L.H. side of cockpit wind-screen						1	MR	C.	J.8
26FC/2879	B.00366ND	PLATE, armour, external, R.H. side of cockpit wind-screen						1	MR	C.	
	B.00657	PLATE, armour, on bulkhead No. 2, L.H. side ...						1	—		J.1
	B.00658	PLATE, armour, on bulkhead No. 2, R.H. side ...						1	—		J.1
28D/12738	AS.2920/17E	Attaching parts for B.00657 and B.00658, Plates :—									
28D/12871	A26/18E	Bolt, 1/4" BSF ...						3	—	C.	
		Bolt, 1/4" BSF ...						3	—	C.	
	A.007403	PLATE, blanking for aerials in Port and Starboard gun bays						1	—		
		Attaching parts for A.007403 Plate :—									
28D/8312	AS.1242/8C	Bolt, 2 BA ...						8	—	C.	
	R.002423	PLATE, blanking, bulkhead No. 1, port, 3-0 dia. x 10G, S.3						1	—		J.3
		Attaching parts for R.002423 Plate :—									
28D/12514	A25/7C	Bolt, 2 BA ...						4	—	C.	
28M/10288	AGS.2001/C/1	Nut, 2 BA ...						4	—	C.	
28W/12252	SP.13/C	Washer ...						4	—	C.	
26FC/2001	R.00105	Washer, joint ...						2	—	C.	
26FC/11162	A.007379A	PLATE, clamp, for aerials in gun bays, Port and Starboard						2	—	C.	
		Attaching parts for A.007379A Plate :—									
28D/8312	AS.1242/8C	Bolt, 2 BA ...						8	—	C.	
	Z.001275	PLATE, cover, for camera aperture in nose ...						1	—		
		Attaching parts for Z.001275 Plate :—									
28D/12627	A25/11B	Bolt, 4 BA ...						1	—	C.	
	Z.001372	Plug, camera aperture ...						1	—		
	Z.001373ND	Washer, M.S., S.3, 2-25 o/d x 12 SWG ...						1	—		
	Z.001277	Washer, saddle ...						1	—		
	12 F 2122ND	PLATE, earth, aluminium foil sheet for type 91 aerial, Rebecca 3' x 3', .007 thick, R.H. (Mod. Ven. 866)						1	—		
	12 F 2121ND	PLATE, earth, aluminium foil sheet for type 91 aerial, Rebecca 3' x 3', .007 thick, L.H. (Mod. Ven. 866)						1	—		
	12 CF 131	PLATE, guard, for pulleys, on fireproof bulkhead 22 SWG, L.72						2	MR		
		Attaching parts for 12 CF 131 Plate :—									
28D/12708	AS.1246/9C	Bolt, 2 BA ...						1	MR	C.	
	AS.2809/4/034	Tube, distance, 1/4" o/d x 0-34 long x 22 SWG, T.4 (Make from Ref. No. 30B/555)						1	MR		
	AS.2809/4/050	Tube, distance, 1/4" o/d x 0-50 long x 22 SWG, T.4 (Make from Ref. No. 30B/555)						1	MR		

FUSELAGE COMPLETE

Ref. No.	Part No.	Nomenclature						No. Off	M.R.	Cl. of St.	Plate No.
		1	2	3	4	5	6				
1665	12 F 663A	PLATE, hinge, between ammunition boxes for oxygen bottles						1	—	C.	J.6
26BY/2573	A.98486	PLATE, locking, accumulator stowage ... ..						4	—	C.	
	12 F 759A/2	PLATE, mounting, for control locking gear, complete with bag, attached to side armour, bulkhead No. 2						1	—		
	12 F 769A	BAG, complete with Carr "dot" fastener, button and studs						1	—		J.5
28E/10038	AS.2294/3	CLIP, spring, for fuel and hydraulic tank filler cap spanner						1	—	C.	
28E/10043	AS.2294/6	CLIP, spring, for fuel and hydraulic tank filler cap spanner						2	—	C.	
	12 F 1303ND	PLATE, mounting, bare ... ..						1	—		J.5
28D/12540	A25/18C	Attaching parts for 12 F 759A/2 Plate :—						1	—	C.	
28D/12739	AS.2920/18E	Bolt, 2 BA ... ..						2	—	C.	
	12 F 1113ND	Washer, packing, .75 dia. x $\frac{1}{32}$ " thick, DTD.423, with hole drilled No. 11						1	—		J.5
26FC/11801	A.007385A	PLATE, nut, for aerials in port and starboard gun bays						2	—	C.	
	A.001457A	PLATE, nut, for pilot's side armour, bottom, on bulkhead No. 2						2	—		J.6
	A.001455A	PLATE, nut, for pilot's side armour, top, on bulkhead No. 2						2	—		J.6
26FC/1949	A.001005A	PLATE, nut, inboard of ammunition boxes ... ..						2	—	C.	J.6
26FC/1949	A.001002A	PLATE, nut, on ammunition box, for oxygen bottle strap anchor bracket						4	—	C.	J.6
	A.004031A	PLATE, nut, on bulkhead No. 3 ... ..						2	—		
26FC/1947	A.001001A	PLATE, nut, on R.H. ammunition box ... ..						1	—	C.	J.6
	A.004032A	PLATE, nut, on R.H. ammunition box ... ..						2	—		J.6
	12 FS 113A	PLATE, packing, for joint plate, at top of air duct orifice, L.H.						1	M.R.		J.7
	12 FS 114A	PLATE, packing, for joint plate, at top of air duct orifice, R.H.						1	M.R.		J.7
	12 FS 111A	PLATE, reinforcing, outer, at top of air duct orifice, L.H.						1	M.R.		J.7
	12 FS 112A	PLATE, reinforcing, outer, at top of air duct orifice, R.H.						1	M.R.		J.7
	12 F 307	PLATE, strap, at bulkhead No. 3, front ... ..						1	M.R.		J.5
	12 F 309	PLATE, strap, at bulkhead No. 3, rear ... ..						1	M.R.		J.5
		Attaching parts for 12 F 307 and 12 F 309, Plates (per pair) :—									
28D/8509	AS.1242/14C	Bolt, 2 BA ... ..						4	M.R.	C.	
28D/11007	AS.1242/14E	Bolt, $\frac{1}{4}$ " BSF ... ..						21	M.R.	C.	
28L/13124	A27/CT	Locknut, 2 BA ... ..						4	M.R.	C.	
28L/12931	A27/ET	Locknut, $\frac{1}{4}$ " BSF ... ..						21	M.R.	C.	
26BY/2856	DHS.33 Mk. 2	Washer, $\frac{1}{4}$ " BSF, shrinkage ... ..						42	M.R.	C.	
574	12 FS 353	PLATE, strap, between engine locating eye-bolts on fireproof bulkhead						1	M.R.	C.	J.2
		Attaching parts for 12 FS 353 Plate :—									
28D/8323	AS.1242/2E	Bolt, $\frac{1}{4}$ " BSF ... ..						4	M.R.	C.	
28M/10290	AGS.2001/E/1	Nut, $\frac{1}{4}$ " BSF ... ..						4	M.R.	C.	
	A.00666	PLATE, washer, at top of fireproof bulkhead, 16 SWG, L.72						1	M.R.		J.2

## FUSELAGE COMPLETE

Ref. No.	Part No.	Nomenclature						No. Off	M.R.	Cl. of St.	Plate No.
		1	2	3	4	5	6				
5266	12 F 293A	<b>PLATE</b> , wing forward attachment, front, L.H. and rear, R.H.						2	M.R.	C.	
5267	12 F 294A	<b>PLATE</b> , wing forward attachment, rear, L.H. and front, R.H.						2	M.R.	C.	
		Attaching parts for 12 F 293 and 12 F 294, Plates (per pair) :—									
28D/12870	A26/17E	Bolt, $\frac{1}{4}$ " BSF ... ..						4	M.R.	C.	
28D/3162	A26/19E	Bolt, $\frac{1}{4}$ " BSF ... ..						2	M.R.	C.	
28L/5775	A.16Z/ET	Locknut, $\frac{1}{4}$ " BSF ... ..						6	M.R.	C.	
26FC/8078	DHS.187 Mk. 2	Washer, $\frac{1}{4}$ " BSF, shrinkage ... ..						12	M.R.	C.	
8115	12 FS 459	<b>PRESSING</b> , centre, secured to bulkhead No. 2 ...						1	M.R.	C.	J.1
28L/	MARTIN BAKER A/MBEU/3321	<b>BRACKET</b> , drogue gun release cable ... ..						1	—	C.	
27L/	MARTIN BAKER A/MBEU/3324	<b>BRACKET</b> , T.R. release cable ... ..						1	—	C.	
		Attaching parts for 12 FS 459 Pressing :—									
28D/8316	AS.1242/13C	Bolt, 2 BA ... ..						9	—	C.	
28D/11996	AS.1242/21C	Bolt, 2 BA ... ..						10	—	C.	
28M/10288	AGS.2001/C/1	Nut, 2 BA ... ..						19	—	C.	
28W/12588	SP.18/C	Washer ... ..						19	—	C.	
26BY/3165	DHS.33 Mk. 1	Washer, shrinkage ... ..						QR	—	C.	
576	12 CF 117A	<b>PULLEY</b> , at wing centre section structure lower cross tube						2	M.R.	C.	J.2
		Attaching parts for 12 CF 117A Pulley :—									
28M/12928	A27/EP	Nut, $\frac{1}{4}$ " BSF ... ..						1	M.R.	C.	
28M/12930	A27/ES	Nut, $\frac{1}{4}$ " BSF ... ..						1	M.R.	C.	
28P/12462	SP.9/C8	Pin, split ... ..						1	M.R.	C.	
577	12 CF 125A	Spindle ... ..						1	M.R.	C.	J.2
26FC/1831	A.00943	Washer, saddle ... ..						2	M.R.	C.	J.2
27L/	MARTIN BAKER C/MBEU/17V	<b>RAIL</b> , guide, ejector seat (For use until Mk. 2 Guide Rail is available)						1	—	C.	
27L/	MARTIN BAKER D/MBEU/363V	<b>RAIL</b> , guide, Mk. 2, ejector seat ... ..						1	—	C.	
26FC/2875	A.002081A	<b>RAIL</b> , canopy, L.H. ... ..						1	M.R.	C.	J.8
26FC/2876	A.002082A	<b>RAIL</b> , canopy, R.H. ... ..						1	M.R.	C.	J.8
	12 F 1175	<b>RAMP</b> , for accumulator tray ... ..						2	—	C.	J.2
		Attaching parts for 12 F 1175 Ramp :—									
28M/10288	AGS.2001/C/1	Nut, 2 BA ... ..						2	—	C.	
28S/2778	A31/C24	Screw, 2 BA ... ..						2	—	C.	
26FC/1970	A.00477A/ND	<b>RING</b> , for bulkhead No. 1, L.H. ... ..						1	M.R.	C.	J.8
26FC/1971	A.00478A/ND	<b>RING</b> , for bulkhead No. 1, R.H. ... ..						1	M.R.	C.	J.8
		Attaching parts for A.00477A/ND and A.00478A/ND, Rings :—									
28D/12735	AS.2920/17C	Bolt, 2 BA ... ..						4	M.R.	C.	
28M/13591	A24/CP	Nut, 2 BA ... ..						4	M.R.	C.	
26BY/5871	DHS.34/C	Washer, 2 BA ... ..						4	M.R.	C.	
26FC/5725	DHS.190	Washer, 2 BA, cup ... ..						4	M.R.	C.	

## FUSELAGE COMPLETE

Ref. No.	Part No.	Nomenclature						No. Off	M.R.	Cl. of St.	Plate No.
		1	2	3	4	5	6				
26FC/1968	A.00259A/ND	<b>RING</b> , L.H. bottom portion for fireproof bulkhead						1	MR	C.	J.1
26FC/1969	A.00260A/ND	<b>RING</b> , R.H. centre portion for fireproof bulkhead						1	MR	C.	J.1
26FC/1966	A.00257A/ND	<b>RING</b> , L.H. centre portion for fireproof bulkhead						1	MR	C.	J.1
26FC/1967	A.00258A/ND	<b>RING</b> , R.H. centre portion for fireproof bulkhead						1	MR	C.	J.1
26FC/1964	A.00255A/ND	<b>RING</b> , L.H. top portion for fireproof bulkhead ...						1	MR	C.	J.1
26FC/1965	A.00256A/ND	<b>RING</b> , R.H. top portion for fireproof bulkhead ...						1	MR	C.	J.1
27L/50005	MARTIN BAKER	<b>SEAT</b> , ejector pilot's Mk. 2F fully automatic ...						1	—	A.	J.1
	B.001855A/ND	<b>SHIELD</b> , for E.2A compass ...						1	—		
	B.001851	<b>PLATE</b> ...						1	—		
		Attaching parts for B.001851 Plate :—									
28M/10274	AGS.2001/B/4	Nut 4 BA ...						2	—	C.	
28S/2413	A44/B16	Screw 4 BA ...						2	—	C.	
	B.001849	<b>SHIELD</b> ...						1	—		
	A.005022A/ND	<b>STEP</b> , pilot's access ...						1	—		J.1
28D/10168	AS.1242/11C	<b>BOLT</b> , 2 BA for step tread catch plate ...						1	—	C.	
28D/12512	A25/1C	<b>BOLT</b> , 2 BA for securing outer casing end plate with head drilled No. 52 for locking wire						2	—	C.	
26FC/814	A.001305A	<b>CASING</b> , outer ...						1	—	C.	J.1
32A/106	†	<b>CORD</b> , balloon 6 ozs. F.32 ...						QR	—	C.	J.1
26FC/822	A.001315	<b>GASKET</b> , sealing outer casing end plate ...						1	—	C.	J.1
26FC/815	A.001309A	<b>PLATE</b> , catch step tread ...						1	—	C.	J.1
26FC/818	A.001313A	<b>PLATE</b> , end for outer casing ...						1	—	C.	J.1
26FC/3095	A.001307A/1	<b>PLATE</b> , step release ...						1	—	C.	J.1
26FC/821	A.001311	<b>SPRING</b> , step release plate ...						1	—	C.	J.1
26FC/820	A.001310	<b>SPRING</b> , step return ...						1	—	C.	J.1
26FC/3096	A.001306A/1	<b>STEP</b> ...						1	—	C.	J.1
		Attaching parts for A.005022A/ND Step :—									
28D/13916	A.26/28C	Bolt 2 BA inner ...						1	—	C.	
28D/13160	A26/19C	Bolt 2 BA outer ...						1	—	C.	
28M/10298	AGS.2001/C/2	Nut 2 BA ...						2	—	C.	
28W/12439	SP.19/C	Washer ...						2	—	C.	
26BY/3165	DHS.33 Mk. 1	Washer 2 BA shrinkage ...						4	—	C.	
26FC/3078	A.004066A	<b>STRIP</b> , fastener L.H. for top edge of cannon fairing						1	—	C.	J.4
26FC/3079	A.004065A	<b>STRIP</b> , fastener R.H. for top edge of cannon fairing						1	—	C.	J.4
27FP/353	No. 1-90 DZUS	<b>SPRING</b> , fastener ...						6	—	C.	
26FC/1919	A.001195	<b>STRIP</b> , rubbing rudder pedal L.H. ...						1	—	C.	J.8
26FC/1977	A.001194	<b>STRIP</b> , rubbing rudder pedal R.H. ...						1	—	C.	J.8
1999	J.915	<b>STRIP</b> , sealing gun bay doors front edge on bulkhead No. 2						QR	—	C.	
		Attaching parts for J.915 Strip :—									
26FC/898	A.00420ND	Angle retaining ...						1	—	C.	
1999	J.915	<b>STRIP</b> , sealing gun bay doors hinge edge ...						QR	—	C.	
		Attaching parts for J.915 Strip :—									
28L/13140	A27/BT	Nut 4 BA ...						28	—	C.	
28S/2839	A33/B32	Screw 4 BA ...						14	—	C.	
28S/5691	A33/B40	Screw 4 BA ...						14	—	C.	
30B/1451	†	Strip seal retaining 20 SWG L.72 ...						QR	—	C.	
26FC/3047	B.00943	<b>STRUT</b> , support mounting in nose ...						2	—	C.	
		Attaching parts for B.00943 Strut :—									
28D/12513	A25/2C	Bolt 2 BA ...						1	—	C.	
28M/10288	AGS.2001/C/1	Nut 2 BA ...						1	—	C.	
28W/12252	SP.13/C	Washer ...						1	—	C.	
26FC/1931	B.00115A	<b>TRAY</b> , accumulator mounting inner ...						2	—	C.	

FUSELAGE COMPLETE

Ref. No.	Part No.	Nomenclature						No. Off	M.R.	Cl. of St.	Plate No.
		1	2	3	4	5	6				
	12 F 1509A/ND	TRAY, accumulator mounting outer L.H. ... ..						1	—		J.2
	12 F 1510A/ND	TRAY, accumulator mounting outer R.H. ... ..						1	—		J.2
	12 F 925	BRACKET, accumulator tray L.H. ... ..						1	—		J.2
	12 F 926	BRACKET, accumulator tray R.H. ... ..						1	—		J.2
	12 F 1395	BRACKET, accumulator tray ... ..						2	—		J.2
	12 F 1161A	CABLE, check ... ..						2	—		J.2
	12 F 1163	BRACKET ... ..						1	—		J.2
	12 F 1165	BRACKET ... ..						1	—		J.2
28Y/3004	AGS.136A	THIMBLE ... ..						2	—	C.	
	12 F 1167ND	WIRE, rope 3 cwt. WQ/1P ... ..						1	—		J.2
		Attaching parts for 12 F 1167ND Wire:—									
28D/12512	A25/1C	Bolt 2 BA ... ..						2	—	C.	
28M/10288	AGS.2001/C/1	Nut 2 BA ... ..						2	—	C.	
	12 F 1135	COVER ... ..						1	—		J.2
		Attaching parts for 12 F 1135 Cover:—									
28D/8302	AS.1242/3B	Bolt 4 BA ... ..						2	—	C.	
28M/10287	AGS.2001/B/1	Nut 4 BA ... ..						2	—	C.	
28W/12305	SP.13/B	Washer ... ..						2	—	C.	
	12 F 795A	TRAY, L.H. ... ..						1	—		J.2
	12 F 796A	TRAY, R.H. ... ..						1	—		J.2
	A.007007	HINGE ... ..						1	—		J.2
26FC/1982	B.00117	HINGE, corner ... ..						1	—	C.	J.2
26FC/1983	B.00116	LINK, corner hinge ... ..						1	—	C.	J.2
	12 F 1137	TRAY, drip L.H. ... ..						1	—		
	12 F 1138	TRAY, drip R.H. ... ..						1	—		
		Attaching parts for 12 F 1509A/ND and 12 F 1510A/ND Trays:—									
28D/12512	A25/1C	Bolt 2 BA ... ..						3	—	C.	
28M/13121	A27/CS	Nut 2 BA ... ..						2	—	C.	
26FC/1943	B.00105	Pin hinge ... ..						1	—	C.	
	12 F 1511	Pin hinge ... ..						2	—		J.2
28W/12252	SP13/C	Washer ... ..						4	—	C.	J.2
28W/12296	SP.15/C	Washer ... ..						2	—	C.	
28W/12355	SP.16/C	Washer ... ..						2	—	C.	
1653	12 FS 477A	TRAY, hydraulic tank attached to fuselage decking						1	—	C.	J.1
1654	12 FS 533	BRACKET, strap attachment ... ..						2	—	C.	J.1
8241	12 R 145A	TRAY, mounting for receiver transmitter TR3708 mounted on nose (Mod. Ven. 328)						1	—	B.	P.1
	12 R 169	BAR, locking ... ..						1	—		P.1
	12 R 199	BLOCK, clamp ... ..						2	—		P.1
	12 R 165	NUT, wing ... ..						2	—		P.1
		Attaching parts for 12 R 145A Tray:—									
28D/12674	A25/9E	Bolt 3/4" BSF ... ..						4	—	C.	
28M/10290	AGS.2001/E/1	Nut 3/4" BSF ... ..						4	—	C.	
28W/12298	SP.18/E	Washer ... ..						8	—	C.	
26FC/5811	B.00163	TRUNNION, locking door in front armour bulkhead No. 1						2	—	C.	J.3
26FC/1838	A.00397A	TUBE, bracing L.H. three legged at joint 'B' of fuselage and front spar tube						1	MR	C.	J.2

FUSELAGE COMPLETE

Ref. No.	Part No.	Nomenclature						No. Off	M.R.	Cl. of St.	Plate No.
		1	2	3	4	5	6				
26FC/1839	A.00398A	<b>TUBE</b> , bracing, R.H. three legged, at joint 'B' of fuselage and front spar tube						1	M.R.	C.	J.2
		Attaching parts for A.00397A and A.00398A Tubes :—									
28D/12994	A25,8J	Bolt, $\frac{3}{8}$ " BSF ...						1	M.R.	C.	
26FC/1834	A.00801	Bolt, $\frac{3}{8}$ " BSF at joint plates ...						1	M.R.	C.	J.2
26FC/1835	A.001006ND	Bolt, $\frac{7}{16}$ " BSF ...						1	M.R.	C.	J.2
28M/13123	A27/JS	Nut, $\frac{3}{8}$ " BSF ...						1	M.R.	C.	
38M/13120	A27/LS	Nut, $\frac{7}{16}$ " BSF ...						1	M.R.	C.	
28W/12255	SP.13/J	Washer ...						1	M.R.	C.	
28W/12256	SP.13/L	Washer ...						1	M.R.	C.	
1576	12 FS 567A	<b>TUBE</b> , cross, lower wing centre section structure						1	M.R.	C.	J.2
1202	12 2FS 39	<b>BOLT</b> , for fork-end ...						4	M.R.	C.	
	12 2FS 37	<b>FORK-END</b> , wing attachment, L.H. ...						1	M.R.		J.2
	12 2FS 38	<b>FORK-END</b> , wing attachment, R.H. ...						1	M.R.		J.2
28M/13120	A27/LS	<b>NUT</b> , $\frac{7}{16}$ " BSF, slotted, for fork-end ...						4	M.R.	C.	
1927	12 F 949A	<b>PLATE</b> , fuselage joint, L.H. ...						1	M.R.	C.	J.2
1928	12 F 950A	<b>PLATE</b> , fuselage joint, R.H. ...						1	M.R.	C.	J.2
	12 2FS 33	<b>TUBE</b> (Undrilled) ...						1	M.R.		J.2
28W/12442	SP.15/L	<b>WASHER</b> ...						QR	M.R.	C.	
1203	12 2FS 41	<b>WASHER</b> , saddle ...						8	M.R.	C.	
		Attaching parts for 12 FS 567A Tube :—									
573	12 F 315	Bolt ...						2	M.R.	C.	J.2
28D/12871	A26/18E	Bolt, $\frac{1}{2}$ " BSF ...						12	M.R.	C.	
28D/13162	A26/19E	Bolt, $\frac{1}{2}$ " BSF ...						6	M.R.	C.	
28D/13166	A26/21E	Bolt, $\frac{1}{2}$ " BSF ...						4	M.R.	C.	
28D/12739	AS.2920/18E	Bolt, $\frac{1}{2}$ " BSF ...						6	M.R.	C.	
28D/12742	AS.1242/28E	Bolt, $\frac{1}{2}$ " BSF ...						4	M.R.	C.	
28D/12126	AS.1242/29E	Bolt, $\frac{1}{2}$ " BSF ...						2	M.R.	C.	
1202	12 2FS 39	Bolt, $\frac{7}{16}$ " BSF, special ...						2	M.R.	C.	
28L/12931	A27/ET	Nut, $\frac{1}{4}$ " BSF ...						6	M.R.	C.	
28L/5775	A.16Z/ET	Nut, $\frac{1}{4}$ " BSF ...						28	M.R.	C.	
28M/13123	A27/JS	Nut, $\frac{3}{8}$ " BSF ...						2	M.R.	C.	
28M/13120	A27/LS	Nut, $\frac{7}{16}$ " BSF ...						2	M.R.	C.	
1263	12 2FS 45	Pin, special ...						2	M.R.	C.	J.2
28W/12253	SP.13/E	Washer ...						6	M.R.	C.	
26BY/2856	DHS.33 Mk. 2	Washer, $\frac{1}{4}$ " BSF, shrinkage ...						56	M.R.	C.	
28W/12255	SP.13/L	Washer ...						2	M.R.	C.	
28W/12256	SP.13/L	Washer ...						QR	M.R.	C.	
1203	12 2FS 41	Washer, saddle ...						4	M.R.	C.	
26FC/3903	D.004244	Washer, saddle ...						4	M.R.	C.	
26FC/1831	A.00943	Washer, saddle ...						4	M.R.	C.	
575	12 FS 355	Washer, special ...						2	M.R.	C.	J.2
1575	12 FS 565A	<b>TUBE</b> , cross, upper, wing centre section structure						1	M.R.	C.	J.2
1202	12 2FS 39	<b>BOLT</b> , for fork-end ...						2	M.R.	C.	
	12 2FS 35	<b>FORK-END</b> , L.H. ...						1	M.R.		J.2
	12 2FS 36	<b>FORK-END</b> , R.H. ...						1	M.R.		J.2
28M/13120	A27/LS	<b>NUT</b> , $\frac{7}{16}$ " BSF for fork-end ...						2	M.R.	C.	
952	12 FS 525A	<b>PLATE</b> , fuselage joint, L.H. ...						1	M.R.	C.	J.2
953	12 FS 526A	<b>PLATE</b> , fuselage joint, R.H. ...						1	M.R.	C.	J.2
	12 2FS 31	<b>TUBE</b> (Undrilled) ...						1	M.R.		
1203	12 2FS 41	<b>WASHER</b> , saddle ...						4	M.R.	C.	

FUSELAGE COMPLETE

Ref. No.	Part No.	Nomenclature						No Off.	M.R.	Cl. of St.	Plate No.
		1	2	3	4	5	6				
28W/12442	SP.15/L	<b>WASHER</b> ... ..						QR	M.R.	C.	
		Attaching parts for 12 FS 565A Tube :—									
28D/13162	A26/19E	Bolt, 3/8" BSF ... ..						12	M.R.	C.	
28D/13166	A26/21E	Bolt, 1/2" BSF ... ..						10	M.R.	C.	
28D/12740	AS.2920/19E	Bolt, 3/8" BSF ... ..						4	M.R.	C.	
28D/12126	AS.1242/29E	Bolt, 1/2" BSF ... ..						4	M.R.	C.	
28L/12931	A27/ET	Nut, 3/8" BSF ... ..						4	M.R.	C.	
28L/5775	A16Z/ET	Nut, 1/2" BSF ... ..						26	M.R.	C.	
1263	12 2FS 45	Pin, special ... ..						2	M.R.	C.	
28W/12253	SP.13/E	Washer ... ..						4	M.R.	C.	
26BY/2856	DHS.33 Mk. 2	Washer, 1/2" BSF, shrinkage ... ..						52	M.R.	C.	
26FC/1829	A.00:41	Washer, saddle ... ..						4	M.R.	C.	J.2
26FC/1831	A.00:43	Washer, saddle ... ..						4	M.R.	C.	
10L/16166	†	<b>UNIT</b> , control, bulkhead No. 2, type 909 ... ..						1	—	A.	P.1
		Attaching parts for 10L/16166 Unit :—									
28D/4700	AS.3078/1B	Bolt, 4 BA ... ..						4	—	C.	
28W/12346	SP.10/B	Washer ... ..						4	—	C.	
6A/1998	SIMMONDS GP.512/001/5B1 or	<b>UNIT</b> , power, Pacitor, on front armour plate ... ..						1	—	A.	
6A/1998	SIMMONDS GP.512/001/9	<b>UNIT</b> , power, Pacitor, on front armour plate ... ..						1	—	A.	
		Attaching parts for GP.512/001 Units :—									
28M/10326	AGS.2002/A/1	Nut, 6 BA ... ..						8	—	C.	
28S/3501	A32/A8	Screw, 6 BA ... ..						8	—	C.	
28W/12332	SP.13/A	Washer ... ..						8	—	C.	
26BY/5871	DHS.34/C	<b>WASHER</b> , 2 BA, for fireproof bulkhead securing bolts						24	M.R.	C.	
26BY/3165	DHS.33 Mk. 1	<b>WASHER</b> , 2 BA, shrinkage, for fireproof bulkhead securing bolts						52	M.R.	C.	
26BY/14112	DHS.85 Mk. 2	<b>WASHER</b> , for drainage eyelet in ammunition box floor						4	—	C.	
28W/10754	AGS.567/BB	<b>WASHER</b> , jointing, bomb jettison cable sealing plug on bulkhead No. 2						2	—	C.	
6034	12 F 821ND	<b>WEIGHT</b> , ballast, 9 lbs., in nose R.H. upper ...						1	M.R.	B.	J.1
6039	12 F 829ND	<b>WEIGHT</b> , ballast, 12 lbs. in nose L.H. rear lower ...						1	M.R.	B.	J.1
6036	12 F 825ND	<b>WEIGHT</b> , ballast, 13 lbs. in nose L.H., front lower						1	M.R.	B.	J.1
	12 F 869ND	<b>WEIGHT</b> , ballast, 13 lbs. in nose R.H., front lower						1	—	C.	
356	12 EC 467	<b>WINDOW</b> , for downward identification lamp ...						1	—	C.	
		Attaching parts for 12 EC 467 Window :—									
28D/8308	AS.12:42/3C	Bolt, 2 BA ... ..						6	—	C.	
26FC/2064	L.00:46	Gasket ... ..						1	—	C.	
350	12 EC 449	Mask ... ..						1	—	C.	

COCKPIT CANOPY

Ref. No.	Part No.	Nomenclature						No Off	M,R.	Cl. of St.	Plate No.
		1	2	3	4	5	6				
	—	<b>COCKPIT CANOPY</b> (12 FC 7) ... ..						1	—		
26FC/2882	A.002149	<b>BRACKET</b> , corner, at sealing bracket joint, L.H.						1	MR	C.	JA.1
26FC/2883	A.002150	<b>BRACKET</b> , corner, at sealing bracket joint, R.H.						1	MR	C.	JA.1
1585	12 F 913A	<b>BRACKET</b> , retaining on diaphragm ... ..						1	—	C.	JA.1
		Attaching parts for 12 F 913A, Bracket :—									
28D/12531	A25/3C	Bolt, 2 BA ... ..						8	—	C.	
28M/10288	AGS.2001/C/1	Nut, 2 BA ... ..						8	—	C.	
28W/12252	SP.13/C	Washer ... ..						8	—	C.	
1580	12 FC 41A	<b>CANOPY</b> , sliding, complete ... ..						1	—	B.	JA.1
	A.007211ND	<b>BLOCK</b> , sealing, rubber ... ..						1	—		
28D/8338	AS.1248/3B	<b>BOLT</b> , 4 BA ... ..						2	—	C.	
28D/8339	AS.1248/6B	<b>BOLT</b> , 4 BA ... ..						11	—	C.	
28D/8306	AS.1242/1C	<b>BOLT</b> , 2 BA, securing sealing members to canopy runners						32	—	C.	
	12 FC 11A	<b>CANOPY</b> , Perspex, bare ... ..						1	—		JA.1
1581	12 FC 49A	<b>FAIRING</b> , rear ... ..						1	—	C.	JA.1
1582	12 FC 47A	<b>MEMBER</b> , canopy sealing, L.H. ... ..						1	—	C.	JA.2
1583	12 FC 48A	<b>MEMBER</b> , canopy sealing, R.H. ... ..						1	—	C.	JA.2
28M/13086	A27/BP	<b>NUT</b> , 4 BA ... ..						13	—	C.	
1586	12 FC 63A	<b>RUNNER</b> , canopy, L.H. ... ..						1	MR	C.	JA.2
26FC/4449	A.007015	<b>BOLT</b> , for vertical rollers ... ..						6	—	C.	JA.2
28L/13124	A27/CT	<b>LOCKNUT</b> , 2 BA, thin ... ..						6	—	C.	
26FC/2868	A.001685	<b>PIN</b> , for horizontal roller ... ..						1	—	C.	JA.2
26FC/2870	A.001687	<b>PIN</b> , for horizontal roller ... ..						4	—	C.	JA.2
26FC/2867	A.001684	<b>ROLLER</b> , horizontal, bottom ... ..						5	—	C.	JA.2
26FC/2866	A.001683	<b>ROLLER</b> , horizontal, top... ..						5	—	C.	JA.2
26FC/4448	A.007013	<b>ROLLER</b> , vertical ... ..						6	—	C.	JA.2
	12 FC 59	<b>RUNNER</b> , canopy ... ..						1	—		JA.2
26FC/2869	A.001686	<b>SCREW</b> , flanged, for horizontal roller ... ..						1	—	C.	JA.2
1587	12 FC 65A	<b>RUNNER</b> , canopy, R.H. ... ..						1	MR	C.	JA.2
26FC/4449	A.007015	<b>BOLT</b> , for vertical rollers ... ..						6	—	C.	
28L/13124	A.27/CT	<b>NUT</b> , 2 BA ... ..						6	—	C.	
26FC/2868	A.001685	<b>PIN</b> , for horizontal rollers ... ..						5	—	C.	
26FC/2867	A.001684	<b>ROLLER</b> , horizontal, bottom ... ..						5	—	C.	
26FC/2866	A.001683	<b>ROLLER</b> , horizontal, top... ..						5	—	C.	
26FC/4448	A.007013	<b>ROLLER</b> , vertical ... ..						6	—	C.	
	12 FC 61	<b>RUNNER</b> , canopy ... ..						1	—		JA.2
26FC/2869	A.001686	<b>SCREW</b> , flanged, for horizontal roller ... ..						5	—	C.	
	A.007249ND	<b>SEAL</b> , rubber ... ..						2	—		
8112	12 FC 43ND	<b>STRIP</b> , rubber sealing ... ..						1	MR	C.	
	A.005127ND	<b>STRIP</b> , rubber ... ..						1	—		
	A.005125ND	<b>WASHER</b> , $\frac{1}{2}$ " o/d $\times$ $\frac{1}{16}$ " thick, Linatex (Make from Ref. No. 32C/473)						1	—		
26FC/4273	A.004977A	<b>TUBE</b> , sealing ... ..						1	—	C.	JA.2
26FC/3758	A.002333A/1	<b>CHANNEL</b> , retaining, for canopy seal, L.H. ... ..						1	MR	C.	JA.2
26FC/3757	A.002332A/1	<b>CHANNEL</b> , retaining, for canopy seal, R.H. ... ..						1	MR	C.	JA.2
		Attaching parts for A.002333A/1 and A.002332A/1 Channels :—									
28D/11126	AS.1242/9B	Bolt, 4 BA ... ..						7	MR	C.	
28D/8305	AS.1242/11B	Bolt, 4 BA ... ..						2	MR	C.	
28D/12118	AS.1242/13B	Bolt, 4 BA ... ..						12	MR	C.	
28D/11144	AS.1242/22B	Bolt, 4 BA ... ..						3	MR	C.	
28M/13086	A27/BP	Nut, 4 BA ... ..						25	MR	C.	
32C/471	†	Strip, sealing, $\frac{3}{8}$ " thick, Linatex ... ..						QR	MR	C.	
28W/3088	AGS.163/B	Washer, 4 BA, double spring ... ..						25	MR	C.	

COCKPIT CANOPY

Ref. No.	Part No.	Nomenclature						No. Off	M.R.	Cl. of St.	Plate No.
		1	2	3	4	5	6				
1584	12 FS 721A	<b>DIAPHRAGM</b> , sealing on bulkhead No. 3 ... ..						1	—	C.	JA.1
		Attaching parts for 12 FS 721A, Diaphragm :—									
28D/12625	A25/9B	Bolt, 4 BA ... ..						8	—	C.	
28D/12846	A25/15B	Bolt, 4 BA ... ..						4	—	C.	
28D/8300	AS.1242/1B	Bolt, 4 BA ... ..						2	—	C.	
28M/13C86	A27/BP	Nut, 4 BA ... ..						14	—	C.	
32C/471	†	Strip, sealing, $\frac{3}{32}$ " thick, Linatex ... ..						QR	MR	C.	
28W/12305	SP.13/B	Washer ... ..						12	—	C.	
28W/12307	SP.18/B	Washer ... ..						14	—	C.	
28W/3C88	AGS.163/B	Washer, double spring ... ..						4	—	C.	
—	—	<b>DRIER</b> , air, system (See Separate Unit) ... ..						1	—		
26FC/2887	A.002165A	<b>FAIRING</b> , windscreen, complete with de-icer spray pipe						1	—	C.	JA.1
26FC/6408	A.002662A	<b>PLATE</b> , bottom ... ..						1	—	C.	JA.1
26FC/6404	A.002663	<b>PLATE</b> , cover, 12 SWG, L.59 ... ..						1	—	C.	JA.1
28S/2815	A33/B16	<b>SCREW</b> , 4 BA ... ..						4	—	C.	
		Attachment parts for A.002165A Fairing :—									
28D/8308	AS.1242/3C	Bolt, 2 BA ... ..						12	—	C.	
28D/8313	AS.1242/9C	Bolt, 2 BA ... ..						21	—	C.	
28D/8509	AS.1242/14C	Bolt, 2 BA ... ..						4	—	C.	
28M/10288	AGS.2001/C/1	Nut, 2 BA ... ..						25	—	C.	
	†	Strip, sealing, $\frac{3}{16}$ " thick $\times$ 1-0" wide, Black Rubber						QR	—		
26FC/11771	DHS.34/N	Washer, 2 BA ... ..						23	—	C.	
26BY/3165	DHS.33 Mk. 1	Washer, 2 BA, shrinkage ... ..						50	—	C.	
—	—	<b>GEAR</b> , canopy winding and jettison (See Separate Unit) ... ..						1	—		
26FC/3797	A.004764A	<b>HOUSING</b> , for canopy stop plunger ... ..						1	—	C.	JA.1
		Attaching parts for A.004764A Housing :—									
28D/12626	A25/10B	Bolt, 4 BA ... ..						2	—	C.	
26FC/2891	A.001677A	<b>LATCH</b> , canopy rail, L.H. ... ..						1	—	C.	JA.2
26FC/2892	A.001678A	<b>LATCH</b> , canopy rail, R.H. ... ..						1	—	C.	JA.2
	A.002206	<b>PLATE</b> , retaining, for canopy stop plunger ... ..						1	—		JA.1
26FC/3798	A.004768	<b>PLUNGER</b> , canopy stop ... ..						1	—	C.	JA.1
26FC/2893	A.001675	<b>RAIL</b> , canopy, L.H. ... ..						1	MR	C.	JA.2
26FC/2894	A.001676	<b>RAIL</b> , canopy, R.H. ... ..						1	MR	C.	JA.2
		Attaching parts for A.001675 and A.001676 Rails :—									
28D/8305	AS.1242/11B	Bolt, 4 BA ... ..						4	MR	C.	
28D/12118	AS.1242/13B	Bolt, 4 BA ... ..						2	MR	C.	
28D/10618	AS.1242/14B	Bolt, 4 BA ... ..						7	MR	C.	
28D/13530	AS.1242/15B	Bolt, 4 BA ... ..						2	MR	C.	
28D/11145	AS.1242/23B	Bolt, 4 BA ... ..						2	MR	C.	
28M/13C86	A27/BP	Nut, 4 BA ... ..						17	MR	C.	
	A.002657	Plate, angle, L.H. ... ..						1	MR		
	A.002658	Plate, angle, R.H. ... ..						1	MR		
	A.002767ND	Plate, washer, 18 SWG, L.72 ... ..						1	MR		JA.1
	A.002213	Plate, washer, 18 SWG, L.72 ... ..						1	MR		JA.1
32C/471	†	Strip, sealing, $\frac{3}{32}$ " thick, Linatex ... ..						QR	MR	C.	
28W/3088	AGS.163/B	Washer, 4 BA, double spring ... ..						19	MR	C.	
28W/12307	SP.18/B	Washer ... ..						2	MR	C.	
26FC/6727	12 FC 89A	<b>SEAL</b> , for canopy ... ..						1	—	C.	JA.2
26FC/3472	A.004769	<b>SPRING</b> , for canopy stop plunger ... ..						1	—	C.	JA.1

COCKPIT CANOPY

Ref. No.	Part No.	Nomenclature						No Off	M.R.	Cl. of St.	Plate No.
		1	2	3	4	5	6				
11405	12 FS 381A/1	<b>WINDSCREEN</b> , complete (Mod. Ven. 751) ...						1	MR	A.	JA.1
		(Pre Mod. Ven. 751)									
749	12 FS 381A	<b>WINDSCREEN</b> , complete ... ..						1	MR	A.	JA.1
26FC/2901	A.002143	<b>BLOCK</b> , jointing, bottom rear corner of side						1	—	C.	JA.1
		windscreen, L.H.									
26FC/2902	A.002144	<b>BLOCK</b> , jointing, bottom rear corner of side						1	—	C.	JA/1
		windscreen, R.H.									
28D/8308	AS.1242/3C	<b>BOLT</b> , 2 BA, securing windscreen masks ...						14	—	C.	
26FC/4206	A.002059A/2	<b>CHANNEL</b> , retaining, for canopy seal ... ..						1	—	C.	JA.1
26FC/2899	A.002323	<b>FILLET</b> , front corner, L.H. ... ..						1	—	C.	JA.1
26FC/2900	A.002324	<b>FILLET</b> , front corner, R.H. ... ..						1	—	C.	JA.1
	A.002351ND	Attaching parts for A.002323 and A.002324 Fillets :—									
	A.002305ND	Bolt, 2 BA (Make from Part No. A25/9C, Ref. No. 28D/12534)						1	—		JA.1
		Screw, 2 BA, (Make from Part No. A31/C32, Ref. No. 28S/2790)						1	—		JA.1
28L/11069	AGS.2035/C	Lockwasher ... ..						1	—	C.	
26FC/2904	A.002345	<b>MASK</b> , glazing, for front windscreen ... ..						1	—	C.	JA.1
26FC/4613	A.002331	<b>MASK</b> , glazing, for side windscreen, L.H. ...						1	—	C.	JA/1
26FC/4458	A.002330	<b>MASK</b> , glazing, for side windscreen, R.H. ...						1	—	C.	JA.1
28S/2809	A33/B12	<b>SCREW</b> , 4 BA ... ..						6	—	C.	
28S/2808	A33/C12	<b>SCREW</b> , 2 BA ... ..						18	—	C.	
26FC/2905	A.002321	<b>SEAL</b> , for windscreen, at front corner fillet, L.H.						1	—	C.	JA.1
26FC/2906	A.002322	<b>SEAL</b> , for windscreen, at front corner fillet, R.H.						1	—	C.	JA.1
32C/471	†	<b>STRIP</b> , sealing, $\frac{1}{32}$ " thick, Linatex ... ..						QR	—	C.	
32C/473	†	<b>STRIP</b> , sealing, $\frac{1}{16}$ " thick, Linatex ... ..						QR	—	C.	
32C/474	†	<b>STRIP</b> , sealing, $\frac{1}{8}$ " thick, Linatex ... ..						QR	—	C.	
	†	<b>STRIP</b> , sealing, $\frac{1}{16}$ " thick, Sponge Rubber... ..						QR	—		
	†	<b>STRIP</b> , sealing, $\frac{1}{8}$ " thick, Sponge Rubber ... ..						QR	—		
26FC/3442	A.004774A	<b>WINDSCREEN</b> , front, bullet proof ... ..						1	—	A.	JA.1
26FC/4185	A.005189	<b>WINDSCREEN</b> , side, L.H. ... ..						1	—	A.	JA.1
26FC/4186	A.005190	<b>WINDSCREEN</b> , side, R.H. ... ..						1	—	A.	JA.1
		Attaching parts for 12 FS 381 and 12 FS 381A/1 Windscreens :—									
28D/8300	AS.1242/1B	Bolt, 4 BA ... ..						8	MR	C.	
28D/8301	AS.1242/2B	Bolt, 4 BA ... ..						4	MR	C.	
28D/10168	AS.1242/11C	Bolt, 2 BA ... ..						2	MR	C.	
28D/8316	AS.1242/13C	Bolt, 2 BA ... ..						2	MR	C.	
28D/8317	AS.1242/15C	Bolt, 2 BA ... ..						2	MR	C.	
28D/11527	AS.1242/17C	Bolt, 2 BA ... ..						17	MR	C.	
28D/12189	AS.1242/18C	Bolt, 2 BA ... ..						8	MR	C.	
28D/8318	AS.1242/19C	Bolt, 2 BA ... ..						4	MR	C.	
28D/11244	AS.1242/25C	Bolt, 2 BA ... ..						2	MR	C.	
28D/12121	AS.1242/28C	Bolt, 2 BA ... ..						2	MR	C.	
28M/10287	AGS.2001/B/1	Nut, 4 BA ... ..						10	MR	C.	
28M/10288	AGS.2001/C/1	Nut, 2 BA ... ..						30	MR	C.	
32C/191	†	<b>Strip</b> , sealing, $\frac{1}{32}$ " thick, Linatex ... ..						QR	MR	C.	
	A.002843ND	<b>Strip</b> , packing, tapered ... ..						QR	MR		
26BY/3165	DHS.33 Mk. 1	Washer, 2 BA, shrinkage ... ..						52	MR	C.	
26FC/4079	A.005006ND	Washer, taper ... ..						2	MR	C.	JA.1
26FC/4080	A.005007ND	Washer, taper ... ..						4	MR	C.	JA.1

COCKPIT CANOPY JETTISON AND WINDING GEAR

Ref. No.	Part No.	Nomenclature						No. Off	M.R.	Cl. of St.	Plate No.
		1	2	3	4	5	6				
		<b>COCKPIT CANOPY JETTISON (A.002021)</b>									
		<b>COCKPIT WINDING GEAR (12 FC 149)</b>									
27S/135	SKEFKO I.132629 12 FC 151A/ND	<b>BEARING</b> ballrace, for operating lever spindle						2	—	B.	JB.2
		<b>BOX</b> , gear, complete with lever and torque tube, canopy winding (Mod. Ven. 447) (Pre Mod. Ven. 796)						1	—		JB.2
9800	12 FC 161A/ND	<b>BOX</b> , gear, complete with lever and torque tube, canopy winding (Mod. Ven. 796)						1	—	C.	JB.2
9783	FCT 92	<b>BUSH</b> , $\frac{3}{8}$ " long for lever shaft, "Oilite"...						1	—	C.	JB.2
9782	FCT 80	<b>BUSH</b> , $\frac{7}{16}$ " long for torque tube drive, "Oilite"						2	—	C.	JB.2
26FC/5686	A.00111	<b>GEAR</b> , bevel ... ..						1	—	C.	JB.1
		Attaching parts for A.00111, Gear :—									
26FC/4396	A.005265	Bolt, special ... ..						1	—	C.	JB.1
28M/10288	AGS.2001/C/1	Nut, 2 BA ... ..						1	—	C.	
28W/12252	SP.13/C	Washer ... ..						1	—	C.	
8194	12 FC 123A	<b>HANDLE</b> , complete (Mod. Ven. 447) (Pre Mod. Ven. 796)						1	—	C.	JB.2
9799	12 FC 123A/1	<b>HANDLE</b> , complete (Mod. Ven. 796) ... ..						1	—	C.	JB.2
	12 FC 141	<b>BUTTON</b> ... ..						1	—		JB.2
8197	12 FC 107	<b>CATCH</b> ... ..						1	—	C.	JB.2
		Attaching parts for 12 FC 107, Catch :—									
	12 FC 145ND	Collar for split pin, $\frac{1}{4}$ " o/d $\times$ 22 SWG $\times$ $\frac{1}{2}$ " long, L.55						1	—		JB.2
28P/836	SP.4Y/B10	Pin, shackle ... ..						1	—	C.	
28P/12462	SP.9/C8	Pin, split ... ..						1	—	C.	
8196	12 FC 117	<b>FORK</b> , operating ... ..						1	—	C.	JB.2
		Attaching parts for 12 FC 117, Fork :—									
28P/815	SP.4Y/A5	Pin, shackle ... ..						1	—	C.	
28P/12462	SP.9/C8	Pin, split ... ..						1	—	C.	
	12 FC 111	<b>HANDLE</b> , (Mod. Ven. 447) (Pre Mod. Ven. 796)						1	—		JB.2
	12 FC 157	<b>HANDLE</b> (Mod. Ven. 796) ... ..						—	—		JB.2
8198	12 FC 105	<b>LEVER</b> ... ..						1	—	C.	JB.2
8199	12 FC 109	<b>SPIGOT</b> ... ..						1	—	C.	JB.2
8195	12 FC 121	<b>SPRING</b> ... ..						1	—	C.	JB.2
	12 FC 119ND	<b>WASHER</b> , $\frac{1}{4}$ " o/d $\times$ 22 SWG, DTD.124A						2	—		JB.2
		Attaching parts for 12 FC 123A, and 12 FC 123A/1 Handles :—									
28D/12535	A25/10C	Bolt, 2 BA ... ..						1	—	C.	
28M/10288	AGS.2001/C/1	Nut, 2 BA ... ..						1	—	C.	
28W/12296	SP.15/C	Washer ... ..						1	—	C.	
	12 FC 143	<b>HOUSING</b> , gear box ... ..						1	—		JB.2
	A.00113	<b>PINION</b> , bevel gear for torque tube drive ...						1	—		JB.2
8201	12 FC 133	<b>PLATE</b> , back ... ..						1	—	C.	JB.2
	12 FC 125	<b>PLATE</b> , stop ... ..						1	—		JB.2
		Attaching parts for 12 FC 125, Plate :—									
28S/2815	A33/B16	Screw, 4 BA ... ..						5	—	C.	
8200	12 FC 115	<b>SHAFT</b> ... ..						1	—	C.	JB.2
	A.00565A	<b>TUBE</b> , torque ... ..						1	—		JB.2
	A.001887ND	<b>JOINT</b> , universal coupling ... ..						1	—		JB.2
		(Make from Ref. No. 26FC/6698)									
26FC/6698	MOLLART No. 01	<b>JOINT</b> , universal coupling ... ..						1	—		JB.2
		(required to make A.00187ND)									

COCKPIT CANOPY JETTISON AND WINDING GEAR

Ref. No.	Part No.	Nomenclature						No. Off	M.R.	Cl. of St.	Plate No.
		1	2	3	4	5	6				
	A.002038ND	<b>RIVET</b> , for universal coupling joint, $\frac{3}{32}$ " dia. $\times$ 0.75 long S.1						2	—		
		Attaching parts for 12 FC 151A/ND and 12 FC 161A/ND									
		Box :—									
28D/8315	AS1242/12C	Bolt, 2 BA	...	...	...	...	8	—	C.		
8202	12 FC 135	Gasket	...	...	...	...	1	—	C.	JB.2	
28M/10288	AGS.2001/C,1	Nut, 2 BA	...	...	...	...	8	—	C.		
28W/12252	SP.13/C	Washer	...	...	...	...	8	—	C.		
26FC/2885	A.001673	<b>BRACKET</b> , angle, inner, mounting jettison release lever at canopy rail						2	—	C.	JB.1
26FC/2884	A.001674	<b>BRACKET</b> , angle, outer, mounting jettison release lever at canopy rail						2	—	C.	JB.1
		Attaching parts to A.001673 and A.001674, Brackets :—									
28D/12118	AS.1242/13B	Bolt, 4 BA, for inner bracket	...	...	...	...	2	—	C.		
28D/11126	AS.1242/9B	Bolt, 4 BA, for outer bracket	...	...	...	...	2	—	C.		
28M/13086	A27/BP	Nut, 4 BA	...	...	...	...	2	—	C.		
26BY/5937	DHS.95	Washer, 4 BA, cup	...	...	...	...	2	—	C.		
26FC/2907	A.002024A	<b>BRACKET</b> , Pulley mounting, on bulkhead No. 3						1	—	C.	JB.1
		Attaching parts for A.002024A, Bracket :—									
28D/12537	A25/14C	Bolt, 2 BA	...	...	...	...	2	—	C.		
28M/12929	A27/CP	Nut, 2 BA	...	...	...	...	2	—	C.		
26BY/5871	DHS.34/C	Washer, 2 BA	...	...	...	...	2	—	C.		
26BY/3165	DHS.33 Mk. 1	Washer, 2 BA, shrinkage	...	...	...	...	4	—	C.		
8203	12 FC 139	<b>BUTTON</b> , outside canopy release						1	—		JB.2
		Attaching parts for 12 FC 139, Button :—									
28W/12346	SP.10/B	Washer	...	...	...	...	QR	—	C.		
8204	12 FC 131	<b>BUTTON</b> , plunger for canopy winding gear						1	—	C.	JB.2
26FC/3075	A.004098A	<b>CABLE</b> , canopy jettison						1	—	C.	JB.1
		Attaching parts for A.004098A, Cable :—									
26BY/1057	L.95574	Bobbin, clamping, at hand lever	...	...	...	...	1	—	C.		
28D/8306	AS.1242/C	Bolt, 2 BA, at hand lever	...	...	...	...	1	—	C.		
28M/10288	AGS.2001/C,1	Nut, 2 BA, at hand lever	...	...	...	...	1	—	C.		
28P/827	SP.4Y/B1	Pin, shackle, at operating lever	...	...	...	...	1	—	C.		
28P/12462	SP.9/C8	Pin split, at operating lever	...	...	...	...	1	—	C.		
26BY/5923	H.24654	Washer, cup	...	...	...	...	1	—	C.		
26FC/2914	A.002318A	<b>CABLE</b> , canopy release						1	—	C.	JB.1
		Attaching parts for A.002318A, Cable :—									
28P/827	SP.4Y/B1	Pin, shackle	...	...	...	...	1	—	C.		
28P/12462	SP.9/C8	Pin, split	...	...	...	...	1	—	C.		
26FC/2915	A.002320	<b>CLIP</b> , spring, for canopy release cable handle						1	—	C.	JB.1
		Attaching parts for A.002320, Clip :—									
28S/2809	A33/B12	Screw, 4 BA	...	...	...	...	1	—	C.		
	A.005115	<b>CLIP</b> , tubular, for jettison cable conduit						1	—		
	DHS.30 Mk. 36	<b>CLIP</b> , tubular, for jettison cable conduit						2	—		
		Attaching parts for A.005115 and DHS.30 Mk. 36, Clips :—									
28D/12512	A25/1C	Bolt, 2 BA	...	...	...	...	1	—	C.		
28L/11069	AGS.2035/C	Lockwasher	...	...	...	...	1	—	C.		
27K/196	DS.56/2	<b>CONDUIT</b> , for jettison cable, Teleflex No. 2						QR	—	C.	

COCKPIT CANOPY JETTISON AND WINDING GEAR

Ref. No.	Part No.	Nomenclature						No. Off	M.R.	Cl. of St.	Plate No.
		1	2	3	4	5	6				
26FC/2300	A.00526A	<b>GEARS</b> , complete with bracket, canopy winding, on bulkhead No. 2						1	—	B.	JB.2
26FC/2295	A.00527A	<b>BRACKET</b> , mounting ... ..						1	—		JB.2
	FGH.97	<b>BUSH</b> , Oilite ... ..						3	—	C.	
26FC/6698	A.00528	<b>GEAR</b> , bevel ... ..						1	—		JB.2
	A.001887ND	<b>JOINT</b> , universal coupling (Make from Ref. No. 26FC/6698)						1	—		JB.2
26FC/2301	No. 01 MOLLART	<b>JOINT</b> , universal coupling (Required to make Part No. A.001887ND)						1	—	C.	JB.2
	A.00531	<b>NUT</b> , seal retaining ... ..						1	—		JB.2
	A.00529	<b>PINION</b> , bevel gear, torque tube drive ... ..						1	—		JB.2
	A.00530	<b>PINION</b> , gear ... ..						1	—		JB.2
	A.00532	<b>PLUG</b> , splined, for universal joint ... ..						1	—		JB.2
	A.002038ND	<b>RIVET</b> , for universal coupling joint, $\frac{3}{16}$ " dia. x 0.75" long, S.1						4	—		JB.2
	26FC/2301	B.341	<b>SEAL</b> , on bevel gear pinion shaft, Angus ... ..						1	—	C.
A.00848		<b>SHIM</b> , under bevel gear ... ..						1	—		JB.2
Attaching parts for A.00526A Gears :—											
28D/12567	A25/20C	Bolt, 2 BA ... ..						4	—	C.	
26FC/2299	A.00535	Gasket ... ..						1	—	C.	JB.2
28M/10288	AGS.2001/C/1	Nut, 2 BA ... ..						4	—	C.	
26FC/2317	A.00536	Plate, washer, for bolts ... ..						2	—	C.	JB.2
26FC/5385	A.004061	Shim ... ..						1	—	C.	JB.2
28W/12252	SP.13/C	Washer ... ..						4	—	C.	
26FC/2898	A.001665	<b>GEAR-WHEEL</b> , on canopy rail, for canopy winding						1	—	C.	JB.2
Attaching parts for A.001665 Gear-wheel :—											
28M/12928	A27/EP	Nut, $\frac{1}{2}$ " BSF ... ..						1	—	C.	
28W/12253	SP.13/E	Washer ... ..						1	—	C.	
1592	12 FC 75A	<b>GUARD</b> , for jettison control cable ... ..						1	—	C.	JB.2
	A.001667	<b>HOUSING</b> , ball-race bearing, for operating lever spindle, on bulkhead No. 3						2	—		JB.1
Attaching parts for A.001667 Housing :—											
28D/13530	AS.1242/15B	Bolt, 4 BA ... ..						4	—	C.	
28M/10287	AGS.2001/B/1	Nut, 4 BA ... ..						4	—	C.	
26FC/2920	A.001104	<b>LABEL</b> , " Important, Cabin Blower—Closing Canopy "						1	—		JB.2
	A.002035A	<b>LEVER</b> , hand, complete with bracket, canopy jettison						1	—	C.	JB.2
28D/11255	AS.1246/2C	<b>BOLT</b> , 2 BA ... ..						1	—	C.	
	A.002032A	<b>BRACKET</b> , mounting ... ..						1	—		JB.2
28M/13121	A.001049	<b>COVER</b> , for spring ... ..						1	—		JB.2
	A.002031	<b>LEVER</b> , jettison ... ..						1	—		JB.2
28P/813	A27/CS	<b>NUT</b> , 2 BA ... ..						1	—	C.	
	SP.4Y/A3	<b>PIN</b> , shackle, for cable ... ..						1	—	C.	
28P/12462	SP.9/C8	<b>PIN</b> , split ... ..						2	—	C.	
26FC/2313	A.001047	<b>SPINDLE</b> , for lever ... ..						1	—		JB.2
	A.001048	<b>SPRING</b> ... ..						1	—	C.	JB.2
28U/8237	SP.8Z/13	<b>THIMBLE</b> , for cable ... ..						1	—	C.	
28W/12252	SP.13/C	<b>WASHER</b> ... ..						1	—	C.	
Attaching parts for A.002035A Lever :—											
28S/2856	A32/C12	Screw, 2 BA ... ..						3	—	C.	
28L/11069	AGS.2035/0	Lockwasher ... ..						3	—	C.	

COCKPIT CANOPY JETTISON AND WINDING GEAR

Ref. No.	Part No.	Nomenclature						No. Off	M.R.	Cl. of St.	Plate No.
		1	2	3	4	5	6				
26FC/3590	A.004192A	<b>LEVER</b> , jettison release, at canopy rail ... ..						2	—	C.	JB.1
		Attaching parts for A.004192A Lever :—									
28D/12532	A25/4C	Bolt, 2 BA ... ..						1	—	C.	
28M/10288	AGS.2001/C/1	Nut, 2 BA ... ..						1	—	C.	
	A.002037ND	Tube, distance, $\frac{5}{16}$ " o/d $\times$ 17 SWG $\times$ 0.27" long, T.35 (Make from Ref. No. 30A/1924)						1	—		JB.1
28W/12324	SP.15/G	Washer ... ..						2	—	C.	
2179	12 F 303A	<b>LEVER</b> , operating, jettison gear connecting rods, on bulkhead No. 3, L.H.						1	MR	B.	JB.1
2178	12 F 301A	<b>LEVER</b> , operating, jettison gear connecting rods, on bulkhead No. 3, R.H.						1	MR	B.	JB.1
28L/12931	A27/ET	<b>LOCKNUT</b> , $\frac{1}{8}$ " BSF, thin, for spring anchor pin						1	—	C.	
28L/13326	A27/GT	<b>LOCKNUT</b> , $\frac{5}{16}$ " BSF, thin, for connecting rod pin						1	—	C.	
28M/10287	AGS.2001/B/1	<b>NUT</b> , 4 BA, for crank plate... ..						6	MR	C.	
26FC/2911	A.002001	<b>PIN</b> , spring anchor, for L.H. lever ... ..						1	—	C.	JB.1
26FC/4464	A.001699	<b>PIN</b> , spring anchor, for R.H. lever ... ..						1	—	C.	JB.1
26FC/2912	A.002005	<b>PIN</b> , for connecting rod ... ..						1	—	C.	JB.1
758	A.004057	<b>PLATE</b> , crank, for L.H. lever ... ..						1	MR	C.	JB.1
759	A.001688	<b>PLATE</b> , crank, for R.H. lever ... ..						1	MR	C.	JB.1
2180	12 F 595A/ND	<b>SPINDLE</b> ... ..						1	MR	C.	JB.1
		Attaching parts for 12 F 303A and 12 F 301A Levers :—									
28M/12930	A27/ES	Nut, $\frac{1}{8}$ " BSF ... ..						1	—	C.	
28P/12462	SP.9/C8	Pin, split ... ..						1	—	C.	
28W/12253	SP.13/E	Washer ... ..						1	—	C.	
8207	12 FC 137	<b>PLATE</b> , cover, for outside canopy release knob ... ..						1	—	C.	JB.2
	A.004121A	<b>PLATE</b> , nut, for operating lever bottom stop, on bulkhead No. 3						1	—		JB.1
8205	12 FC 129	<b>PLUNGER</b> , button for canopy winding gear ... ..						1	—	C.	JB.2
28R/13491	AS.107	<b>PULLEY</b> , shrouded, for canopy jettison cable ... ..						1	—	B.	JB.1
		Attaching parts for AS.107 Pulley :—									
28D/12633	A25/7E	Bolt, $\frac{1}{4}$ " BSF ... ..						1	—	C.	
28M/10290	AGS.2001/E/1	Nut, $\frac{1}{4}$ " BSF ... ..						1	—	C.	
26FC/2923	A.001693A	<b>ROD</b> , connecting, jettison gear, operating levers ... ..						1	—	C.	JB.1
26FC/2924	A.001691	<b>FORK-END</b> ... ..						1	—	C.	JB.1
28L/12931	A27/ET	<b>LOCKNUT</b> , $\frac{1}{8}$ " BSF, thin ... ..						1	—	C.	
		Attaching parts for A.001693A Rod :—									
28P/863	SP.4Y/D5	Pin, shackle ... ..						2	—	C.	
28P/12462	SP.9/C8	Pin, split ... ..						2	—	C.	
28W/12496	SP.15/E	Washer ... ..						2	—	C.	
26FC/2921	A.002004A	<b>ROD</b> , connecting, operating lever to jettison lever						2	—	C.	JB.1
26FC/2922	A.002003	<b>EYE-END</b> ... ..						1	—	C.	JB.1
28R/10911	AGS.593/L	<b>EYE-END</b> , L.H. thread ... ..						1	—	C.	
28L/13326	A27/GT	<b>LOCKNUT</b> , $\frac{5}{16}$ " BSF, thin ... ..						1	—	C.	
28L/13247	A27/GTL	<b>LOCKNUT</b> , $\frac{5}{16}$ " BSF, thin, L.H. thread ... ..						1	—	C.	
		Attaching parts for A.002004A Rod :—									
28D/12566	A25/6C	Bolt, 2 BA ... ..						1	—	C.	
28M/10288	AGS.2001/C/1	Nut, 2 BA ... ..						1	—	C.	
28P/12462	SP.9/C8	Pin, split ... ..						1	—	C.	
28W/12324	SP.15/G	Washer ... ..						1	—	C.	

COCKPIT CANOPY JETTISON AND WINDING GEAR

Ref. No.	Part No.	Nomenclature						No. Off	M.R.	Cl. of St.	Plate No.
		1	2	3	4	5	6				
26FC/2925	A.002007A	<b>SEAL</b> , for jettison cable, on bulkhead No. 2						1	—	C.	JB.2
26BY/14435	SEEGER	<b>CIRCLIP</b> , internal, for $\frac{3}{32}$ " dia. bore						1	—	C.	JB.2
26FC/1672	K.00214	<b>FERRULE</b> , housing, for sealing washers						1	—	C.	JB.2
28N/9796	SP/21	<b>NIPPLE</b> , grease						1	—	C.	
26FC/2325	K.00217 Mk. 2	<b>WASHER</b> , half, for sealing washers						4	—	C.	JB.2
26FC/2323	K.00215	<b>WASHER</b> , sealing						8	—	C.	JB.2
26FC/2324	K.00216	<b>WASHER</b> , sealing						6	—	C.	JB.2
Attaching parts for A.002007A Seal :—											
28D/12539	A25/16C	Bolt, 2 BA						4	—	C.	
26FC/2916	A.002036	Gasket, under seal						1	—	C.	JB.2
28M/10288	AGS.2001/C/1	Nut, 2 BA						4	—	C.	
26FC/11771	DHS.34/N	Washer, 2 BA						4	—	C.	
26BY/3165	DHS.33 Mk. 1	Washer, 2 BA, shrinkage						8	—	C.	
26FC/2897	A.001666	<b>SPINDLE</b> , for canopy winding gear-wheel on canopy rail						1	—	C.	JB.2
Attaching parts for A.001666 Spindle :—											
28D/10618	A.002675A	Bolt, 4 BA, captive						1	—		JB.2
28M/10287	AS.1242/14B	Bolt, 4 BA						2	—	C.	
26FC/7121	AGS.2001/B/1	Nut, 4 BA						3	—	C.	
26FC/7121	A.004060	Shim						1	—	C.	JB.2
28W/12305	SP.13/B	Washer						3	—	C.	
26FC/3074	A.004091	<b>SPRING</b> , for jettison gear operating levers, on bulkhead No. 3						2	—	C.	JB.1
Attaching parts for A.004091 Spring :—											
26FC/2908	A.002015	Bolt						1	—	C.	JB.1
28L/12931	A27/ET	Locknut, $\frac{1}{4}$ " BSF						1	—	C.	
28M/12929	A27/CP	Nut, 2 BA						1	—	C.	
28W/12252	SP.13/C	Washer						1	—	C.	
26BY/15712	DHS.57 Mk. 3	Washer, $\frac{1}{4}$ " BSF (Make from Ref. No. 26BY/5720)						2	—	C.	
26BY/5720	DHS.34/D	Washer, $\frac{1}{4}$ " BSF (Required to make Part No. DHS.57 Mk. 3)						2	—	C.	
26BY/2856	DHS.33 Mk. 2	Washer, $\frac{1}{4}$ " BSF, shrinkage						2	—	C.	
8206	12 FC 127	<b>SPRING</b> , for outside canopy release button						1	—	C.	JB.2
	A.00568A	<b>SOCKET</b> , spline, for torque tube (Mod. Ven. 477)						1	—		JB.2
Attaching parts for A.00568A Socket :—											
28D/12533	A25/5C	Bolt, 2 BA						1	—	C.	
28M/10288	AGS.2001/C/1	Nut, 2 BA						1	—	C.	
	A.002783	Pin, $\frac{1}{8}$ " dia. x 0-90" long, S.1						3	—		JB.2
	A.004048A	<b>STOP</b> , bottom, operating lever, on bulkhead No. 3						1	—		JB.1
	A.004051	<b>BOLT</b> , stop						1	—		JB.1
	A.004052A	<b>BRACKET</b> , housing						1	—		JB.1
28M/10288	AGS.2001/C/1	<b>NUT</b> , 2 BA						1	—	C.	
26FC/3625	A.004050	<b>SPRING</b>						1	—	C.	JB.1
Attaching parts for A.004048A Stop :—											
28D/12287	AS.1246/14E	Bolt, $\frac{1}{4}$ " BSF						4	—	C.	
	A.002893ND	Shim						1	—		JB.1
26FC/2926	A.002176A	<b>STOP</b> , top, operating lever, on bulkhead No. 3						1	—	C.	JB.1
26FC/2927	A.002175	<b>BUFFER</b>						1	—	C.	JB.1
28M/12929	A27/CP	<b>NUT</b> , 2 BA						1	—	C.	
28W/12253	SP.13/C	<b>WASHER</b>						1	—	C.	
Attaching parts for A.002176A Stop :—											
28D/12287	AS.1246/14E	Bolt, $\frac{1}{4}$ " BSF						3	—	C.	
28M/12928	A27/EP	Nut, $\frac{1}{4}$ " BSF						3	—	C.	
	DHS.34/P	Washer, $\frac{1}{4}$ " BSF						3	—		
26BY/2856	DHS.33 Mk. 2	Washer, $\frac{1}{4}$ " BSF, shrinkage						6	—	C.	

FIREPROOF BULKHEAD AND ACCESSORIES

Ref. No.	Part No.	Nomenclature						No Off	M.R.	Cl. of St.	Plate No.
		1	2	3	4	5	6				
	—	<b>FIREPROOF BULKHEAD AND ACCESSORIES</b>						<b>1</b>	—		
		(12 E 9A)									
590	12 P 203	<b>ADAPTOR</b> , fuel pipe, bottom, R.H. ... ..						<b>1</b>	MR	C.	JC.1
28F/12076	AGS.1114/C	<b>ADAPTOR</b> , pipe, above dive brake pipe line junction block						<b>1</b>	—	C.	
28F/12771	AGS.1112/J	<b>ADAPTOR</b> , pipe above fuel cock ... ..						<b>1</b>	—	C.	
	12 F 615	<b>ADAPTOR</b> , pipe, centre, top L.H. ... ..						<b>1</b>	—		JC.1
		(Make from 28F/12772)									
28F/10790	AGS.1114/B	<b>ADAPTOR</b> , pipe, inner, top, L.H. ... ..						<b>1</b>	—	C.	
28F/12772	AGS.1114/BB	<b>ADAPTOR</b> , pipe, outer, top, L.H. ... ..						<b>1</b>	—	C.	
	Q.002053	<b>BLOCK</b> , junction for dive brake pipe lines ... ..						<b>1</b>	—		JC.1
28F/9838	AGS.1104/A	<b>ADAPTOR</b> , pipe ... ..						<b>4</b>	—	C.	
28F/10410	AGS.1104/C	<b>ADAPTOR</b> , pipe ... ..						<b>2</b>	—	C.	
26FC/2368	Q.00213	<b>BLOCK</b> , junction ... ..						<b>1</b>	—	C.	JC.1
28F/8225	AGS.1138/A	<b>WASHER</b> , jointing ... ..						<b>4</b>	—	C.	
28F/9649	AGS 1138/C	<b>WASHER</b> , jointing ... ..						<b>2</b>	—	C.	
		Attaching parts for Q.002053 Block :—									
28D/10618	AS.1242/14B	Bolt, 4 BA ... ..						<b>3</b>	—	C.	
28M/13086	A27/BP	Nut, 4 BA ... ..						<b>3</b>	—	C.	
28L/11067	AGS.2035/B	Lockwasher ... ..						<b>3</b>	—	C.	
	12 S 1683A	<b>BLOCK</b> , junction, for dive brake pipe lines ... ..						<b>1</b>	—		JC.1
28F/9838	AGS.1104/A	<b>ADAPTOR</b> , pipe ... ..						<b>4</b>	—	C.	
28F/10410	AGS.1104/C	<b>ADAPTOR</b> , pipe ... ..						<b>4</b>	—	C.	
26FC/2368	Q.00213	<b>BLOCK</b> , junction ... ..						<b>1</b>	—	C.	
28F/10799	AGS.1129/C	<b>BODY</b> , banjo ... ..						<b>2</b>	—	C.	
28F/9730	AGS.1135/C	<b>BOLT</b> , banjo ... ..						<b>2</b>	—	C.	
28F/8225	AGS.1138/A	<b>WASHER</b> , jointing ... ..						<b>4</b>	—	C.	
28F/9649	AGS.1138/C	<b>WASHER</b> , jointing ... ..						<b>4</b>	—	C.	
		Attaching parts for 12 S 1683A Block :—									
28D/10618	AS.1242/14B	Bolt, 4 BA ... ..						<b>3</b>	—	C.	
28M/13086	A27/BP	Nut, 4 BA ... ..						<b>3</b>	—	C.	
28L/11067	AGS.2035/B	Lockwasher ... ..						<b>3</b>	—	C.	
	Q.002052A	<b>BLOCK</b> , junction, hydraulic, on front face of fireproof bulkhead						<b>1</b>	—		JC.1
28F/9839	AGS.1104/A	<b>ADAPTOR</b> , pipe ... ..						<b>4</b>	—	C.	
28F/9708	AGS.1104/B	<b>ADAPTOR</b> , pipe ... ..						<b>2</b>	—	C.	
28F/10797	AGS.1129/A	<b>BANJO</b> ... ..						<b>4</b>	—	C.	
26FC/2369	Q.002051	<b>BLOCK</b> , junction ... ..						<b>1</b>	—	C.	JC.1
28F/10795	AGS.1136/A	<b>BOLT</b> , banjo ... ..						<b>4</b>	—	C.	
28F/8225	AGS.1138/A	<b>WASHER</b> , jointing ... ..						<b>12</b>	—	C.	
28F/8215	AGS.1138/B	<b>WASHER</b> , jointing ... ..						<b>2</b>	—	C.	
		Attaching parts for Q.002052A Block :—									
26BY/3109	DHS.14/G	Bolt, 2 BA ... ..						<b>2</b>	—	C.	
	6421	<b>BLOCK</b> , pump lines junction, bottom of bulkhead ...						<b>1</b>	MR	B.	JC.1
28F/10110	AGS.1105/C	<b>ADAPTOR</b> , pipe ... ..						<b>1</b>	—	C.	
28F/11266	AGS.1105/D	<b>ADAPTOR</b> , pipe ... ..						<b>1</b>	—	C.	
	1018	<b>BLOCK</b> , junction ... ..						<b>1</b>	—	C.	JC.1
26FC/2629	Q.00521A	<b>VALVE</b> , non-return pressure lines ... ..						<b>1</b>	—	B.	JC.1
26FC/2631	Q.00172	<b>ADAPTOR</b> , pipe ... ..						<b>1</b>	—	C.	JC.1
26FC/2630	Q.00173	<b>BODY</b> , valve ... ..						<b>1</b>	—	C.	JC.1
26BY/1466	Q.95212	<b>GUIDE</b> , valve ... ..						<b>1</b>	—	C.	JC.1
28F/9731	AGS.1140/C	<b>PLUG</b> , nipple ... ..						<b>1</b>	—	C.	
28F/5604	AGS.904/C	<b>SLEEVE</b> , outer ... ..						<b>1</b>	—	C.	
26BY/1471	Q.98130	<b>SPRING</b> ... ..						<b>1</b>	—	C.	JC.1

FUSELAGE

FIREPROOF BULKHEAD AND ACCESSORIES

Ref. No.	Part No.	Nomenclature						No. Off	M.R.	Cl. of St.	Plate No.
		1	2	3	4	5	6				
26BY/5940	62417 Q.00814										
26FC/2632	Q.00520A										
26FC/2631	Q.00172										
26FC/2633	Q.00517										
26BY/4164	Q.9838										
26BY/1466	Q.95212										
26FC/2634	Q.00518										
26BY/1471	Q.98130										
26FC/2628	Q.00519										
	Q.00814										
28F/9651	AGS.1138/D										
28F/9649	AGS.1138/C										
28F/9651	AGS.1138/D										
28D/12630	A25/19C										
28M/10288	AGS.2001/C/1										
26FC/5175	13 S 819										
28W/12252	SP.13/C										
28D/8311	AS.1242/7C										
28D/12515	A25/10C										
28D/12528	A25/1B										
28D/12512	A25/1C										
28D/12531	A25/3C										
	12 F 1917A/1										
	12 FS 1365A/ND										
3647	12 F 475A										
26FC/1851	A.00961A										
26FC/1850	A.00949										
	A.00947										
	12 F 1155A										
26FC/1851	A.00961A										
26FC/1850	A.00949										
	12 F 1159										
	A.007009										
2757	12 F 347ND										
32B/1044	BN.4										
26BY/13994	X.72										
30B/	†										
886	12 S 641A										
	12 FS 1283A/ND										
7115	12 F 345ND										
	12 F 23ND										
28D/12512	A25/1C										
3646	12 F 191A										

FIREPROOF BULKHEAD AND ACCESSORIES

Ref. No.	Part No.	Nomenclature						No. Off	M.R.	Cl. of St.	Plate No.
		1	2	3	4	5	6				
26FC/1884 32B/1044	A.00704 BN.4	<b>STIFFENER</b> , centre rear ... .. <b>STRIP</b> , rubbing 1".0 wide x $\frac{3}{32}$ " thick Ferobestos Bells Asbestos						1 QR	MR —	C. C.	JC.1
	A.002743A Mk. 1	<b>CHAIN</b> , for dust cap of non-return valve suction line						1	—		
	A.002743A Mk. 2	<b>CHAIN</b> , for non-return valve pressure line ...						1	—		
7271	12 CE 289	<b>CHANNEL</b> , electrical conduit, 20 SWG, L.72 ...						1	MR	C.	
	12 CE 43	<b>CLAMP</b> , cable, 16 SWG, S.84 (Make from 30A/2161)						2	MR		JC.1
27F/2203	40G/10	<b>COCK</b> , fuel, Saunders ... .. Attaching parts for 40G/10 Cock :—						1	—	A.	
28D/12531	A25/3C	Bolt, 2 BA ... ..						3	—	C.	
28M/10288	AGS.2001/C/1	Nut, 2 BA ... ..						1	—	C.	
28W/12252	SP.13/C	Washer ... ..						1	—	C.	
28F/10785	AGS.1145/A	<b>COUPLING</b> , pipe... ..						6	—	C.	
28F/9533	AGS.1145/B	<b>COUPLING</b> , pipe... ..						1	—	C.	
28F/10431	AGS.1147/B	<b>COUPLING</b> , pipe canopy seal ... ..						1	—	C.	
1133	12 P 307A	<b>COVER</b> , for fuel cock ... ..						1	—	C.	JC.1
	12 CF 535	<b>FAIRLEAD</b> , for flying controls ... ..						2	MR		JC.1
	12 CF 537	<b>FAIRLEAD</b> , for flying controls ... ..						2	MR		JC.1
		Attaching parts for 12 CF 535 and 12 CF 537 Fairleads :—									
28D/8312	AS.1242/8C	Bolt, 2 BA ... ..						1	MR	C.	
28D/8313	AS.1242/9C	Bolt, 2 BA ... ..						2	MR	C.	
6410	12 CF 483	<b>FAIRLEAD</b> , for flying controls ... ..						1	MR	C.	JC.1
6411	12 CF 485	<b>FAIRLEAD</b> , for flying controls ... ..						1	MR	C.	JC.1
	12 CF 487	<b>FAIRLEAD</b> , for flying controls ... ..						1	—		JC.1
	12 CF 489	<b>FAIRLEAD</b> , for flying controls ... ..						1	—		JC.1
		Attaching parts for 12 CF 483, 12 CF 485, 12 CF 487 and 12 CF 489 Fairleads (per pair) :—									
28D/12622	A25/3B	Bolt, 4 BA ... ..						6	—	C.	
28M/10287	AGS.2001/B/1	Nut, 4 BA ... ..						6	—	C.	
28F/10491	AGS.1148/A	<b>LOCKNUT</b> , for pipe coupling ... ..						6	—	C.	
28F/9584	AGS.1148/B	<b>LOCKNUT</b> , for pipe coupling ... ..						2	—	C.	
28M/13086	A27/BP	<b>NUT</b> , 4 BA, for bolts securing pipe adaptors ... ..						6	—	C.	
28M/12929	A27/CP	<b>NUT</b> , 2 BA, for bolts securing pipe adaptors ... ..						9	—	C.	
28M/10288	AGS.2001/C/1	<b>NUT</b> , 2 BA, for bolts securing pipe adaptors ... ..						11	—	C.	
	12 CE 45	<b>PLATE</b> , cable clamp, 14 SWG, L.72 ... ..						2	MR		JC.1
		Attaching parts for 12 CE 45 Plate :—									
28D/12512	A25/1C	Bolt, 2 BA ... ..						2	MR	C.	
28M/10288	AGS.2001/C/1	Nut, 2 BA ... ..						2	MR	C.	
5254	12 CE 99	<b>PLATE</b> , mounting, fuel cock ... ..						1	MR	C.	JC.1
		Attaching parts for 12 CE 99 Plate :—									
28D/12513	A25/2C	Bolt, 2 BA ... ..						4	MR	C.	
28D/8307	AS.1242/2C	Bolt, 2 BA ... ..						2	MR	C.	
28M/10288	AGS.2001/C/1	Nut, 2 BA ... ..						5	MR	C.	
28M/10328	AGS.2002/C/1	Nut, 2 BA ... ..						1	MR	C.	
28W/12252	SP.13/C	Washer ... ..						6	MR	C.	
26BY/17540	DHS.180 Mk. 3X	<b>TAG</b> , for locking wire ... ..						3	—	C.	
28F/8215	AGS.1138/B	<b>WASHER</b> , jointing, for canopy seal pipe coupling ...						1	—	C.	
28F/8225	AGS.1138/A	<b>WASHER</b> , jointing, for pipe coupling ... ..						12	—	C.	
28F/8215	AGS.1138/B	<b>WASHER</b> , jointing, for pipe coupling ... ..						2	—	C.	
28W/12252	SP.13/C	<b>WASHER</b> , for bolts securing pipe adaptors ... ..						11	—	C.	

GUN BAY DOORS

Ref. No.	Part No.	Nomenclature						No Off	M.R.	Cl. of St.	Plate No.
		1	2	3	4	5	6				
6669	12 FS 905A/1	<b>GUN BAY DOOR, L.H.</b> ... ..						1	—	A.	JD.1
9729	12 FS 205A/8	<b>GUN BAY DOOR, R.H.</b> ... ..						1	—	A.	JD.1
26FC/899	A.001137A	<b>BLOCK</b> , stop, top rear of door ... ..						1	MR	C.	JD.1
1478	12 F 269A	<b>BRACKET</b> , for fastener hook, L.H. door ... ..						3	MR	C.	JD.2
3668	12 F 275	<b>BOLT</b> ... ..						1	MR	C.	JD.2
28M/12928	A27/EP	<b>NUT</b> , 1/4" BSF ... ..						1	MR	C.	
		Attaching parts for 12 F 269A, Bracket :—									
28D/12767	AS.2920/13E	Bolt, 1/2" BSF ... ..						2	MR	C.	
28D/12769	AS.2920/15E	Bolt, 1/2" BSF ... ..						2	MR	C.	
28D/12738	AS.2920/17E	Bolt, 1/2" BSF ... ..						2	MR	C.	
28M/13271	A24/EP	Nut, 1/2" BSF ... ..						6	MR	C.	
1307	12 FS 313	Plate, washer ... ..						1	MR	C.	JD.2
597	12 FS 39	<b>BRACKET</b> , hinge, forward and centre ... ..						2	MR	C.	JD.1
596	12 FS 37	<b>BRACKET</b> , hinge, rear ... ..						1	MR	C.	JD.1
		Attaching parts for 12 FS 39 and 12 FS 37, Brackets :—									
28D/13005	A26/16C	Bolt, 2 BA ... ..						2	MR	C.	
28D/13007	A26/15E	Bolt, 1/2" BSF ... ..						2	MR	C.	
28M/13591	A24/CP	Nut, 2 BA ... ..						2	MR	C.	
28M/13271	A24/EP	Nut, 1/2" BSF ... ..						2	MR	C.	
2183	12 FS 53A	<b>BRACKET</b> , support, forward hinge, front L.H. and rear R.H. ... ..						1	MR	C.	JD.2
2184	12 FS 54A	<b>BRACKET</b> , support, forward hinge, front R.H. and rear L.H. ... ..						1	MR	C.	JD.2
3664	12 FS 41A	<b>BRACKET</b> , support, rear and centre hinge, front, L.H. rear R.H. ... ..						2	MR	C.	JD.2
3665	12 FS 42A	<b>BRACKET</b> , support, rear and centre hinge, front R.H. rear L.H. ... ..						2	MR	C.	JD.2
		Attaching parts for 12 FS 53A, 12 FS 54A, 12 FS 41A and 12 FS 42A, Brackets (per pair) :—									
28D/12864	A26/10C	Bolt, 2 BA ... ..						3	MR	C.	
28D/13168	A26/10E	Bolt, 1/2" BSF ... ..						2	MR	C.	
28D/12737	AS.2920/8E	Bolt, 1/2" BSF, for centre hinge brackets ... ..						1	MR	C.	
28D/12657	AS.2920/6E	Bolt, 1/2" BSF, for forward hinge brackets ... ..						1	MR	C.	
28D/12762	AS.2920/7E	Bolt, 1/2" BSF, for rear hinge brackets ... ..						1	MR	C.	
28M/13591	A24/CP	Nut, 2 BA ... ..						3	MR	C.	
28M/13271	A24/EP	Nut, 1/2" BSF ... ..						3	MR	C.	
	DHS.191	Washer, 1/2" BSF, cup ... ..						1	MR		
26FC/3023	S.00299A	<b>CHUTE</b> , ammunition, empty case and link, for inner cannon, on L.H. door ... ..						1	—	C.	JD.1
26FC/3024	S.00300A	<b>CHUTE</b> , ammunition, empty case and link, for inner cannon, on R.H. door ... ..						1	—	C.	JD.1
26FC/3025	S.00311A	<b>CHUTE</b> , ammunition, empty case and link for outer cannon, on L.H. door ... ..						1	—	C.	JD.1
26FC/3026	S.00312A	<b>CHUTE</b> , ammunition, empty case and link, for outer cannon, on R.H. door ... ..						1	—	C.	JD.1
		Attaching parts for S.00299A, S.00300A, S.00311A and S.00312A, Chutes :—									
28D/12118	AS.1242/13B	Bolt, 4 BA ... ..						4	—	C.	
28M/10287	AGS.2001/B/1	Nut, 4 BA ... ..						4	—	C.	
26BY/5937	DHS.95	Washer, 4 BA, cup ... ..						4	—	C.	

FUSELAGE

GUN BAY DOORS

Ref. No.	Part No.	Nomenclature						No. Off	M.R.	Cl. of St.	Plate No.
		1	2	3	4	5	6				
26FC/6958	12 A 521A	<b>EXTENSION</b> , ammunition chute for inner cannon on L.H. door						1	—	C.	JD.1
26FC/6959	12 A 522A	<b>EXTENSION</b> , ammunition chute for inner cannon on R.H. door						1	—	C.	JD.1
26FC/6960	12 A 525A	<b>EXTENSION</b> , ammunition chute for outer cannon on L.H. door						1	—	C.	JD.1
26FC/6961	12 A 526A	<b>EXTENSION</b> , ammunition chute for outer cannon on R.H. door						1	—	C.	JD.1
		Attaching parts for 12 A 521A, 12 A 522A, 12 A 525A and 12 A 526A, Extensions :—									
28D/9354	AS.1248/6C	Bolt, 2 BA ... ..						4	—	C.	
28M/10288	AGS.2001/C/1	Nut, 2 BA ... ..						4	—	C.	
5K/3372	AS.3360/C/5B	Strip, bonding ... ..						1	—	C.	
26BY/7642	DHS.56 Mk. 4	Washer ... ..						4	—	C.	
26BY/14110	DHS.84 Mk. 4	<b>EYELET</b> , drainage ... ..						8	—	C.	
740	12 F 135A	<b>FASTENER</b> , toggle, R.H. door ... ..						3	—	C.	JD.2
744	12 F 321A	<b>DOOR</b> ... ..						1	—	C.	JD.2
741	12 F 147	<b>EYE-BOLT</b> ... ..						1	MR	C.	JD.2
3666	12 F 151	<b>HANDLE</b> ... ..						1	MR	C.	JD.2
742	12 F 149	<b>HOOK</b> ... ..						1	MR	C.	JD.2
743	12 F 267ND	<b>LOCKNUT</b> ... ..						1	MR	C.	JD.2
26FC/11776	3 EC 1173	<b>PEG</b> , locating ... ..						1	—	C.	JD.2
	12 F 265ND	<b>PIN</b> , hook securing ... ..						1	MR	C.	JD.2
26FC/1532	L.00109	<b>PIN</b> , shackle ... ..						1	—	C.	JD.2
28P/12463	SP.9/E10	<b>PIN</b> , split ... ..						2	—	C.	
28P/12792	SP.9/E4	<b>PIN</b> , split, for safety cable attachment ... ..						1	—	C.	
27FP/341	S.5/325 DZUS	<b>SPRING</b> ... ..						1	—	C.	
		Attaching parts for 12 F 135A, Fastener :—									
28D/12766	AS.2920/12E	Bolt, " BSF ... ..						2	MR	C.	
28D/12769	AS.2920/15E	Bolt, " BSF ... ..						2	MR	C.	
28D/12739	AS.2920/18E	Bolt, " BSF, for centre and rear fasteners ... ..						2	MR	C.	
28D/12741	AS.2920/20E	Bolt, " BSF, for centre and rear fasteners ... ..						2	MR	C.	
28D/12767	AS.2920/13E	Bolt, " BSF, forward fastener ... ..						2	MR	C.	
28D/12768	AS.2920/14E	Bolt, " BSF, for forward fastener ... ..						2	MR	C.	
28L/5775	A.16Z/ET	Locknut, " BSF, for forward fasteners ... ..						8	MR	C.	
28M/13271	A24/EP	Nut, " BSF, for centre and rear fasteners ... ..						8	MR	C.	
747	12 F 155ND	Plate, washer ... ..						1	MR	C.	JD.2
28W/13388	12 FS 371ND	Washer, tapered, for centre and rear fasteners ... ..						8	MR	C.	JD.2
	SP.14/E	Washer ... ..						8	—	C.	
26FC/1917	G.00559	<b>LABEL</b> , " Nose Wheel—Locking Tools," L.H. door ... ..						1	—	C.	JD.2
	G.00557A	<b>PENNANT</b> , compelte with plug for main undercarriage locking on ground, stowed in pouch on L.H. door						2	—	C.	JD.1
	A.00339	<b>PLATE</b> , seal, along front edge of L.H. door, 16 SWG, L.72						1	—	C.	JD.1
	A.00340	<b>PLATE</b> , seal, along front edge of R.H. door, 16 SWG, L.72						1	—	C.	JD.1
	A.007367	<b>PLATE</b> , seal along inner edge of door L.H., 16 SWG, L.72 (Make from 30B/ )						1	—	C.	JD.2

GUN BAY DOORS

Ref. No.	Part No.	Nomenclature						No. Off	M.R.	Cl. of St.	Plate No.
		1	2	3	4	5	6				
	A.007368	<b>PLATE</b> , seal, along inner edge of door R.H., 16 SWG, L.72 (Make from 30B/1728)						1	—		JD.2
		Attaching parts for A.007367 and A.007368 Plates :—									
28D/9294	AS.1242/5B	Bolt, 4 BA ... ..						5	—	C.	
28D/12285	AS.1242/20B	Bolt, 4 BA ... ..						1	—	C.	
28M/10287	AGS.2001/B/1	Nut, 4 BA ... ..						6	—	C.	
28W/12306	SP.15/B	Washer ... ..						6	—	C.	
	A.00337	<b>PLATE</b> , seal, along outer edge of L.H. door, 16 SWG, L.72 (Make from 30B/1728)						1	—		JD.1
	A.00338	<b>PLATE</b> , seal, along outer edge of R.H. door, 16 SWG, L.72 (Make from 30B/1728)						1	—		JD.1
	A.00335	<b>PLATE</b> , seal, along rear edge of L.H. door, 16 SWG, L.72 (Make from 30B/1728)						1	—		JD.1
	A.00336	<b>PLATE</b> , seal, along rear edge of R.H. door, 16 SWG, L.72 (Make from 30B/1728)						1	—		JD.1
26FC/1961	G.00554A	<b>PLUG</b> , screwed, for main undercarriage locking on ground, stowed in pouch on L.H. door						2	—	C.	JD.2
26FC/915	G.00558A	<b>POUCH</b> , stowage, for main undercarriage locking plugs, on L.H. door						1	—	C.	JD.1
26BY/13994	X.72	<b>STRIP</b> , sealing, along inner edge of door ... ..						QR	—	C.	
10340	12 F 1647A	<b>TUBE</b> , vent, for fuel, on R.H. Door ... .. (Mod. Ven. 738)						1	—	C.	
		Attaching parts for 12 F 1647A, Tube :—									
8761	12 F 1585	Block, packing (Mod. Ven. 551) ... ..						1	—	C.	
28D/12537	A25/14C	Bolt, 2 BA ... ..						1	—	C.	
28D/8509	AS.1242/14C	Bolt, 2 BA ... ..						4	—	C.	
28M/10288	AGS.2001/C/1	Nut, 2 BA ... ..						5	—	C.	
8836	12 F 1665	Plate, flanged (Mod. Ven. 738) ... ..						1	—	C.	
8837	12 F 1947	Seal, rubber (Mod. Ven. 738) ... ..						1	—	C.	
28W/12252	SP.13/C	Washer ... ..						5	—	C.	
	12 F 1591ND	Washer, special (Make from 3/8" dia. bar S.1) ... ..						5	—		
26BY/5693	DHS.18 Mk. 2	<b>WASHER</b> , drainage at gun stirrup hole ... ..						1	—	C.	
26BY/14112	DHS.85 Mk. 2	<b>WASHER</b> , for drainage eyelet ... ..						8	—	C.	

INSTRUMENT PANELS

Ref. No.	Part No.	Nomenclature						No. Off	M.R.	Cl. of St.	Plate No.
		1	2	3	4	5	6				
	—	<b>INSTRUMENT PANELS</b> (12 F 1923) ... ..						1	—	—	JE.1
26FC/954	B.0056	<b>ANGLE</b> , at bottom of L.H. and R.H. panels ... ..						4	—	C.	JE.1
26FC/953	B.0055	<b>ANGLE</b> , at side of L.H. and R.H. panels ... ..						9	—	C.	JE.1
		Attaching parts for B.0056 and B.0055, Angles :—									
28L/11069	AGS.2035/C	Lockwasher, 2 BA ... ..						1	—	C.	
28S/2856	A32/C12	Screw, 2 BA ... ..						1	—	C.	
	B.00631	<b>ANGLE</b> , at top of L.H. panel, 18 SWG, L.72 ... ..						1	—	—	JE.1
	B.00632	<b>ANGLE</b> , at top of R.H. panel, 18 SWG, L.72 ... ..						1	—	—	JE.1
		Attaching parts for B.00631 and B.00632, Angles :—									
28D/12528	A25/1B	Bolt, 4 BA ... ..						1	—	C.	
28M/10287	AGS.2001/B/1	Nut, 4 BA ... ..						1	—	C.	
26FC/7977	B.002695A	<b>BRACKET</b> , mounting, bottom for blind flying panel (Pre Mod. Ven. 780)						2	—	B.	JE.2
10A/9335	LORD.150.P.6	<b>MOUNTING</b> , anti-vibration ... ..						1	—	B.	JE.2
		Attaching parts for B.002695A, Bracket :—									
28D/12512	A25/1C	Bolt, 2 BA ... ..						4	—	C.	
28W/12252	SP.13/C	Washer ... ..						4	—	C.	
11419	12 F 2019A	<b>BRACKET</b> , mounting, bottom for blind flying panel (Mod. Ven. 780)						2	—	B.	
27H/2782	†	<b>MOUNTING</b> , anti-vibration, rubber ... ..						1	—	B.	
		Attaching parts for 12 F 2019A, Bracket :—									
28D/12512	A25/1C	Bolt, 2 BA ... ..						4	—	C.	
28W/12252	SP.13/C	Washer ... ..						4	—	C.	
2379	12 F 1009A	<b>BRACKET</b> , mounting, top for blind flying panel (Pre Mod. Ven. 780)						1	—	B.	JE.2
10A/9335	LORD 150.P6	<b>MOUNTING</b> , anti-vibration ... ..						1	—	B.	
11417	12 F 2017A	<b>BRACKET</b> , mounting, top, for blind flying panel, L.H. (Mod. Ven. 780)						1	—	B.	
27H/2785	†	<b>MOUNTING</b> , anti-vibration ... ..						1	—	B.	
11418	12 F 2015A	<b>BRACKET</b> , mounting, top, for blind flying panel, R.H. (Mod. Ven. 780)						1	—	B.	
27H/2785	†	<b>MOUNTING</b> , anti-vibration ... ..						1	—	B.	
		Attaching parts for 12 F 2017A and 12 F 2015A, Brackets :									
28D/12546	A25/14E	Bolt, 1/2" BSF ... ..						4	—	C.	
28M/10290	AGS.2001/E/1	Nut, 1/2" BSF ... ..						4	—	C.	
10A/17930	†	Washer, check ... ..						12	—	C.	
	12-4 F 31A/1	<b>PANEL</b> , blind flying, complete with instruments (Mod. Ven. 780)						1	—	—	JE.1
	12 F 1049A/3	<b>PANEL</b> , blind flying, complete with instruments (Pre Mod. Ven. 780)						1	—	—	JE.1
6A/3156 or 6A/3381	†	<b>ALTIMETER</b> ... ..						1	—	A.	JE.1
		Attaching parts for Air Ministry Ref. No. 6A/3156 or 6A/3381, Altimeter :—									
28M/10275	AGS.2001/C/4	Nut, 2 BA ... ..						4	—	C.	
28S/2442	A44/C40	Screw, 2 BA ... ..						4	—	C.	

FUSELAGE

INSTRUMENT PANELS

Ref. No.	Part No.	Nomenclature						No. Off	M.R.	Cl. of St.	Plate No.
		1	2	3	4	5	6				
28V/11696	AGS.838/6							1	—	C.	
28V/5107	AGS.838/2							1	—	C.	
5L/X951273	†							1	—	B.	
6A/3147	†							1	—	A.	JE.1
								Attaching parts for Air Ministry Ref. No. 6A/3147, Indicator :—			
28M/10275	AGS.2001/C/4							4	—	C.	
28S/2442	A44/C40							4	—	C.	
6A/2526	†							4	—	C.	
6A/3849	†							1	—	A.	JE.1
6A/3063	†							1	—	A.	JE.1
6B/2035	SPERRY							1	—	A.	JE.1
								Attaching parts for Air Ministry Ref. No. 6B/2035, Indicator :—			
28S/2424	A44/C24							4	—	C.	
6A/2966	†							1	—	A.	JE.1
								Attaching parts for Air Ministry Ref. No. 6A/2966, Indicator :—			
28M/10275	AGS.2001/C/4							3	—	C.	
6A/1539	†							1	—	C.	
28S/2151	A45/B32							4	—	C.	
6A/2945	†							1	—	A.	JE.1
								Attaching parts for Air Ministry Ref. No. 6A/2945, Indicator :—			
28M/10274	AGS.2001/B/4							4	—	C.	
28S/2431	A44/B28							4	—	C.	
5CX/1069	12 F 2125							1	—	A.	
28V/5108	†							1	—	A.	
	AGS.838/4							12	—	C.	
	12 F 1005A/2							1	—	—	JE.1
6A/—	W.6216/3							1	—	—	JE.1
								BRACKET, for altimeter and air speed indicator pipe connections			
								Attaching parts for W.6216/3, Bracket :—			
28M/10274	AGS.2001/B/4							3	—	C.	
28S/2127	A45/B16							3	—	C.	
26FC/5723	B.002687A							3	—	C.	JE.1
								Attaching parts for B.002687A, Bracket :—			
28M/10283	AGS.2001/G/3							1	—	C.	
28W/12254	SP.13/G							1	—	C.	
6A/2519	W.6216/1							2	—	C.	JE.1
								CONNECTION, pipe, altimeter and air speed indicator			
								Attaching parts for W.6216/1, Connection :—			
28M/13719	A29/ES							1	—	C.	
28P/12462	SP.9/C8							1	—	C.	
	12 F 1619ND							1	—	—	JE.1
								PANEL, bare			

INSTRUMENT PANELS

Ref. No.	Part No.	Nomenclature						No. Off	M.R.	Cl. of St.	Plate No.
		1	2	3	4	5	6				
6A/—	12 F 2221A W.6216/3	<b>PANEL</b> , less instruments (Mod. Ven 780) ...						1	—	—	
		<b>BRACKET</b> , for altimeter and air speed indicator pipe connections						1	—	—	JE.1
		Attaching parts for W.6216/3, Bracket :—									
28M/10274	AGS.2001/B/4	Nut, 4 BA ...						3	—	C.	
28S/2127	A45/B16	Screw, 4 BA ...						3	—	C.	
11414	12 F 2001A	<b>BRACKET</b> , suspension, L.H. ...						1	—	C.	
11415	12 F 2021A	<b>BRACKET</b> , suspension, R.H. ...						1	—	C.	
11416	12 F 2023A	<b>BRACKET</b> , suspension, lower ...						2	—	C.	
		Attaching parts for 12 F 2001A, 12 F 2021A and 12 F 2023A, Brackets :—									
28M/10283	AGS.2001/G/3	Nut, $\frac{3}{16}$ " BSF ...						4	—	C.	
28W/12254	SP.13/G	Washer ...						4	—	C.	
6A/2519	W.6216/1	<b>CONNECTION</b> , pipe for altimeter and air speed indicators						2	—	C.	JE.1
		Attaching parts for W.6216/1, Connection :—									
28M/13719	A29/ES	Nut, $\frac{1}{4}$ " BSF ...						1	—	C.	
28P/12462	SP.9/C8	Pin, split ...						1	—	C.	
	12 F 1619ND	<b>PANEL</b> , bare ...						1	—	—	JE.1
26FC/4741	B.002703ND	<b>PIPE</b> , air speed indicator to pressure connection						1	—	C.	JE.1
2380	12 F 1051ND	<b>PIPE</b> , elbow, at rate of climb indicator to tee-piece at air speed indicator						1	—	C.	JE.1
26FC/4743	B.002701ND	<b>PIPE</b> , tee-piece at air speed indicator to tee-piece at altimeter						1	—	C.	JE.1
26FC/4744	B.002705ND	<b>PIPE</b> , tee-piece at altimeter to static connection						1	—	C.	JE.1
28V/13603	AGS.838/8	<b>RING</b> , rubber, for pipe coupling nuts ...						12	—	C.	
6B/2575	SPERRY	<b>SHIELD</b> , magnetic, for G4F compass ...						1	—	A.	JE.1
28V/5105	AGS.838/2	<b>TEE-PIECE</b> ...						3	—	C.	
	Q.003545ND	<b>TUBE</b> , for blanking tee-piece at rate of climb indicator, $\frac{3}{16}$ " o/d $\times$ $\frac{11}{16}$ " long, $\times$ 20 SWG, L.54						1	—	—	
28V/13604	AGS.838/9	<b>WASHER</b> , for blanking cap at rate of climb indicator						1	—	C.	
		Attaching parts for 12 F 1049/3, Panel :—									
28D/12545	A25/13E	Bolt, $\frac{1}{4}$ " BSF ...						3	—	C.	
28M/10290	AGS.2001/E/1	Nut, $\frac{1}{4}$ " BSF ...						3	—	C.	
28W/12253	SP.13/E	Washer ...						3	—	C.	
8111	12 F 1021A	<b>PANEL</b> , bottom centre, complete ...						1	MR	B.	JE.1
5CZ/430	†	<b>BLOCK</b> , terminal ...						1	MR	B.	JE.1
5CZ/432	†	<b>BLOCK</b> , terminal ...						1	MR	B.	JE.1
5CZ/868	†	<b>BLOCK</b> , terminal ...						1	MR	B.	JE.1
		Attaching parts for 5CZ/430, 5CZ/432 and 5CZ/868, Blocks :—									
28M/10286	AGS.2001/A/1	Nut, 6 BA ...						2	—	C.	
28S/2828	A33/A24	Screw, 6 BA ...						2	—	C.	
	12 F 1023ND	<b>PANEL</b> , bare, $\frac{3}{16}$ " thick, LFS.23 ...						1	—	—	JE.1
		Attaching parts for 12 F 1021A, Panel :—									
28D/11255	AS.1246/2C	Bolt, 2 BA ...						2	—	C.	

INSTRUMENT PANELS

Ref. No.	Part No.	Nomenclature						No. Off	M.R.	Cl. of St.	Plate No.
		1	2	3	4	5	6				
6518	12-4 F 27A/2	<b>PANEL</b> , L.H., complete with instruments ... ..						1	—		
	12 S 1267A	<b>BRACKET</b> , mounting pressure switch on rear of L.H. instrument panel						1	—	C.	JE.2
		Attaching parts for 12 S 1267A, Bracket :—									
28D/14961	AS.4565/3C	Bolt, 2 BA ... ..						4	—	C.	
28M/10288	AGS.2001/C/1	Nut, 2 BA ... ..						4	—	C.	
28W/12296	SP.15/C	Washer ... ..						4	—	C.	
10F/1786	†	<b>BUTTON</b> , push, type 1290 (Mod. Ven 65) ... ..						1	—	B.	
6A/2197	†	<b>CLOCK</b> , Mk. 4 (Mod. Ven 703) OR ... ..						1	—	A.	
6A/2958	†	<b>CLOCK</b> , Mk. 4B, (Mod. Ven 703) OR ... .. (Attaching screws supplied with clocks)						1	—	A.	
6A/2089	†	<b>CLOCK</b> , 5 ACA (Mod. Ven 630) ... ..						1	—	A.	
		Attaching parts for 6A/2089, Clock :—									
28D/12690	AS.1246/5B	Bolt, 4 BA ... ..						2	—	C.	
5L/X951273	†	<b>FILAMENT</b> , for aileron power warning, aileron trim warning, and telescramble lamps 28V, 3-5 watt						3	—	B.	JE.1
5L/X951110	†	<b>FILAMENT</b> , for fuel pressure and generator warning lamps, 6V, 0.24 watt, clear						1	—	B.	JE.1
5L/X951272	†	<b>FILAMENT</b> , for undercarriage position 28V, 3-5 watt, clear						9	—	B.	JE.1
6A/2191	SANGAMO WESTON S.64/2	<b>GAUGE</b> , jet pipe temperature ... ..						1	—	A.	JE.1
		Attaching parts for Air Ministry Ref. No. 6A/2191, Gauge :—									
28D/11210	AS.1246/3C	Bolt, 2 BA ... ..						3	—	C.	
28M/10328	AGS.2002/C/1	Nut, 2 BA ... ..						3	—	C.	
6A/2238	SMITHS 91MV	<b>GAUGE</b> , oil temperature ... ..						1	—	A.	JE.1
		Attaching parts for 91 MV, Gauge :—									
28D/11210	AS.1246/3C	Bolt, 2 BA ... ..						4	—	C.	
28M/10328	AGS.2002/C/1	Nut, 2 BA ... ..						4	—	C.	
5CW/4222	ROTAX ZA.2401	<b>GUARD</b> , for emergency fuel pump switch (Mod. Ven 703)						1	—	B.	
6A/2801	†	<b>INDICATOR</b> , engine revolution, Mk. 10A ... ..						1	—	A.	JE.1
		Attaching parts for Air Ministry Ref. No. 6A/2801, Indicator :—									
28S/2881	A32/B28	Screw, 4 BA ... ..						4	—	C.	
6A/2136	SMITHS 144FL	<b>INDICATOR</b> , flap position ... ..						1	—	A.	JE.1
		Attaching parts for 144FL, Indicator :—									
28D/11890	AS.1246/5C	Bolt, 2 BA ... ..						2	—	C.	
28M/10328	AGS.2002/C/1	Nut, 2 BA ... ..						2	—	C.	
5CX/4204	†	<b>INDICATOR</b> , undercarriage position ... ..						1	—	B.	JE.1
		Attaching parts for Air Ministry Ref. No. 5CX/4204, Indicator :—									
28D/12529	A25/4B	Bolt, 4 BA ... ..						4	—	C.	

INSTRUMENT PANELS

Ref. No.	Part No.	Nomenclature						No Off	M,R.	Cl. of St.	Plate No.
		1	2	3	4	5	6				
26FC/941	12 F 1307	LABEL, "Aileron Trim Warning" ... ..						1	—	—	JE.1
	12 N 2015	LABEL, "Aileron Power Warning" ... ..						1	—	—	JE.1
	12 N 1301	LABEL, "Camera Test" ... ..						1	—	—	JE.1
	12 N 2291	LABEL, "Emergency Fuel Pump Switch" ... ..						1	—	—	—
	B.001063	LABEL, "Fuel Press" ... ..						1	—	—	JE.1
	L.00577	LABEL, "Jet Pipe Temp." ... ..						1	—	C.	JE.1
	12-4S 25	LABEL, "Power Manual" ... ..						1	—	—	—
B.003501	LABEL, "Telescramble" ... ..						1	—	—	—	
		Attaching parts for B.003501, Label :—									
28D/2864	A32/A16	Bolt, 6 BA ... ..						2	—	C.	
28M/10286	AGS.2001/A/1	Nut, 6 BA ... ..						2	—	C.	
5CX/1553	†	LAMP, warning, "fuel pressure," type B, red						1	—	B.	JE.1
5CX/4192	†	LAMP, warning, "aileron trim," amber ... ..						1	—	B.	JE.1
5CX/4191	—	LAMP, warning, "telescramble," type A ... ..						1	—	B.	JE.1
6A/3384	†	MACHMETER ... ..						1	—	A.	JE.1
		Attaching parts for Air Ministry Ref. No. 6A/3384, Machmeter :—									
10A/12954	†	Mounting, anti-vibration ... ..						1	—	B.	
28S/2863	A32/B16	Screw, 4 BA ... ..						4	—	C.	
	12-4S 21	MOUNTING, for power/manual selector valve (Mod. Ven. 560)						1	—	—	—
		Attaching parts for 12-4S 21, Mounting :—									
28D/15384	AS.2922/3C	Bolt, 2 BA ... ..						2	—	C.	
28D/15383	AS.2922/2½C	Bolt, 2 BA ... ..						2	—	C.	
26BY/17540	DHS.180/Mk. 3X	Lug, wire locking ... ..						1	—	C.	
	12-4F 23A/2	PANEL, less instruments (Mod. Ven 560) ... ..						1	—	—	—
26FC/943	B.0053A	BRACKET, for support strut ... ..						1	—	C.	
		Attaching parts for B.0053A, Bracket :—									
28D/8308	AS.1242/3C	Bolt, 2 BA ... ..						1	—	C.	
28D/11255	AS.1246/2C	Bolt, 2 BA ... ..						1	—	C.	
28M/12929	A27/CP	Nut, 2 BA ... ..						2	—	C.	
	12 N 2289	BRACKET, for emergency fuel pump switch						1	—	—	—
26FC/317	DHS.199	TERMINAL, earth ... ..						1	—	C.	
5CW/4226	ROTAX	SWITCH, camera test (Mod. Ven 167) ... ..						1	—	B.	JE.1
		Attaching parts for Air Ministry Ref. No. 5CW/4226, Switch :—									
28L/11067	AGS.2035/B	Lockwasher, 4 BA ... ..						4	—	C.	
28S/2857	A32/B12	Screw, 4 BA ... ..						4	—	C.	
5CW/4184	ROTAX D.5404	SWITCH, emergency fuel pump (Mod. Ven 703)						1	—	B.	
		Attaching parts for Air Ministry Ref. No. 5CW/4184, Switch :—									
28S/13887	A32/B10	Screw, 4 BA ... ..						2	—	C.	
5CW/5502	THERMAL CONTROL TP.5216	SWITCH, high pressure, 1.400 P.S.I. (Mod. Ven 560)						1	—	A.	JE.2
		Attaching parts for TP.5216, Switch :—									
28D/12513	A25/2C	Bolt, 2 BA ... ..						4	—	C.	
28W/12296	SP.15/C	Washer ... ..						4	—	C.	

FUSELAGE

INSTRUMENT PANELS

Ref. No.	Part No.	Nomenclature						No. Off	M.R.	Cl. of St.	Plate No.
		1	2	3	4	5	6				
10L/246	†	<b>UNIT</b> , control, type 382, TR.1934, Radio ...						1	—	A.	JE.1
		Attaching parts for Air Ministry Ref. No. 10L/246, Unit :—									
28D/11255	AS.1246/2C	Bolt, 2 BA ... ..						2	—	C.	
28D/12786	AS.1246/22C	Bolt, 2 BA ... ..						1	—	C.	
28M/10288	AGS.2001/C/1	Nut, 2 BA ... ..						3	—	C.	
—	—	<b>VALVE</b> , selector, power (12-4S 73) ... ..						1	—		
		Consisting of :—									
9228	12-4S 13	<b>KNOB</b> , selector ... ..						1	—	C.	
9230	12-4S 15	<b>NUT</b> , retaining ... ..						1	—	C.	
9229	12-4S 27	<b>PIN</b> , retaining, special ... ..						1	—	C.	
	12-4S 19	<b>SHIM</b> , Attewell, LA.3. $\frac{1}{16}$ " thick ... ..						1	—		
	12-4S 53A/ND	<b>VALVE</b> , selector, comprising ... ..						1	—		
27M/646	LOCKHEED AIR.42164	<b>VALVE</b> , selector ... ..						1	—	A.	
		(See AP.4515F, Vol. 3, Part 1, Section 2, Chapter 11 for breakdown)									
		Attaching parts for AIR.42164, Valve :—									
28F/10410	AGS.1104/C	Adaptor, cone ... ..						2	—	C.	
6503	12 S 1315	Union, cone, special reducing ... ..						1	—	C.	
		(Made from AGS.1107/J)									
28F/11958	AGS.1186/C	Washer ... ..						3	—	C.	
28W/12731	SP.16/B	<b>WASHER</b> , spacer, between emergency fuel pump switch and bracket (Mod. Ven 703)						2	—	C.	
		Attaching parts for 12-4F 27A/2, Panel :—									
28D/12528	A25/1B	Bolt, 4 BA ... ..						1	—	C.	
28D/11255	AS.1246/2C	Bolt, 2 BA ... ..						3	—	C.	
28D/11210	AS.1246/3C	Bolt, 2 BA ... ..						4	—	C.	
28M/10288	AGS.2001/C/1	Nut, 2 BA ... ..						7	—	C.	
28M/10287	AGS.2001/B/1	Nut, 4 BA ... ..						1	—	C.	
	12-4F 53A/2	<b>PANEL</b> , L.H. complete with instruments ... ..						1	—		
		(Mod. Ven 630) (Pre Mod. Ven 751)									
6518	12 S 1267A	<b>BRACKET</b> , mounting, pressure switch on rear of instrument panel						1	—	C.	
		Attaching parts for 12 S 1267A, Bracket :—									
28D/14961	AS.4565/3C	Bolt, 2 BA ... ..						4	—	C.	
28M/10288	AGS.201/C/1	Nut, 2 BA ... ..						4	—	C.	
28VV/12296	SP.15/C	Washer ... ..						4	—	C.	
10F/1786	†	<b>BUTTON</b> , push type 1290 (Mod. Ven 65) ...						1	—	B.	
5L/X951110	†	<b>FILAMENT</b> , fuel pressure warning lamp type A, 6 volt, 24 watt, clear						1	—	B.	
5L/X951273	†	<b>FILAMENT</b> , for aileron power warning, aileron trim warning, and telescrumble warning lamps 28 volt, 3.5 watt, clear						3	—	B.	
5L/X951272	†	<b>FILAMENT</b> , undercarriage indicator, 28 volt, 3.5 watt						9	—	B.	

## INSTRUMENT PANELS

Ref. No.	Part No.	Nomenclature						No Off	M,R.	Cl. of Sc.	Plate No.
		1	2	3	4	5	6				
6A/2191	SANGAMO WESTON S.64/2	<b>GAUGE</b> , jet pipe temperature ... ..						1	—	A.	
28D/11210	AS.1246/3C	Attaching parts for S.64/2, Gauge :— Bolt, 2 BA ... ..						3	—	C.	
28M/10328	AGS.2002/C/1	Nut, 2 BA ... ..						3	—	C.	
6A/2238	SMITHS 91 MV	<b>GAUGE</b> , oil temperature ... ..						1	—	A.	
28D/11210	AS.1246/3C	Attaching parts for 91 MV, Gauge :— Bolt, 2 BA ... ..						4	—	C.	
28M/10328	AGS.2002/C/1	Nut, 2 BA ... ..						4	—	C.	
5CW/4222	ROTAX ZA.2401	<b>GUARD</b> , for emergency fuel pump switch ... .. (Mod. Ven 703)						1	—	B.	
6A/2801	†	<b>INDICATOR</b> , engine revolution, Mk. 10A ... .. (Mod. Ven 151)						1	—	A.	
28S/2881	A32/B28	Attaching parts for 6A/2801, Indicator :— Screw, 4 BA ... ..						4	—	C.	
6A/2136	SMITHS 144 FL	<b>INDICATOR</b> , flap position ... ..						1	—	A.	
28D/11890	AS.1246/5C	Attaching parts for 144FL, Indicator :— Bolt, 2 BA ... ..						2	—	C.	
28M/10328	AGS.2002/C/1	Nut, 2 BA ... ..						2	—	C.	
5CX/4204	†	<b>INDICATOR</b> , undercarriage position ... ..						1	—	B.	
28D/12529	A25/4B	Attaching parts for 5CX/4204, Indicator :— Bolt, 4 BA ... ..						4	—	C.	
	12 N 2015	<b>LABEL</b> , "Aileron Power Warning" ... ..						1	—		
	12 F 1307	<b>LABEL</b> , "Aileron Trim Warning" ... ..						1	—		
	12 N 1301	<b>LABEL</b> , "Camera Test" ... ..						1	—		
	12 N 2291	<b>LABEL</b> , "Emergency Fuel Pump Switch" ... ..						1	—		
	B.001063	<b>LABEL</b> , "Fuel Pressure" ... ..						1	—		
26FC/941	L.00577	<b>LABEL</b> , "Jet Pipe Temperature" ... ..						1	—	C.	
26FC/947	B.00253	<b>LABEL</b> , "Oil temperature" ... ..						1	—	C.	
	12-4S 25	<b>LABEL</b> , "Power Manual" ... ..						1	—		
	B.003501	<b>LABEL</b> , "Telescramble" ... ..						1	—		
		Attaching parts for B.003501, Label :—									
28M/10286	AGS.2001/A/1	Nut, 6 BA ... ..						2	—	C.	
28S/2864	A32/A16	Screw, 6 BA ... ..						2	—	C.	
5CX/4192	†	<b>LAMP</b> , warning, amber, "Aileron trim" ... ..						1	—	B.	
5CX/1553	†	<b>LAMP</b> , warning, "Fuel pressure" (red) ... ..						1	—	B.	
5CX/4191	†	<b>LAMP</b> , warning, type A, "Telescramble" ... ..						1	—	B.	
6A/3384	†	<b>MACHMETER</b> , (Mod. Ven 560) ... ..						1	—	A.	
		Attaching parts for Air Ministry Ref. No. 6A/3384, Machmeter :—									
10A/12954	†	Mounting, anti-vibration ... ..						1	—	B.	
28S/2863	A32/B16	Screw, 4 BA ... ..						4	—	C.	

INSTRUMENT PANELS

Ref. No.	Part No.	Nomenclature						No. Off	M.R.	Cl. of St.	Plate No.
		1	2	3	4	5	6				
	12-4S 21	<b>MOUNTING</b> , for power/manual selector valve (Mod. Ven 560)						1	—		
		Attaching parts for 12-4S 21, Mounting :—									
28D/15384	AS.2922/3C	Bolt, 2 BA ... ..						2	—	C.	
28D/15383	AS.2922/2½C	Bolt, 2 BA ... ..						2	—	C.	
26BY/17540	DHS.180/Mk. 3X	Lug, wire locking ... ..						1	—	C.	
	12-4F 51A/2	<b>PANEL</b> , less instruments (Mod. Ven 560) ...						1	—		
26FC/943	B.0053A	<b>BRACKET</b> , for support strut ... ..						1	—	C.	
		Attaching parts for B.0053A, Bracket :—									
28D/8308	AS.1242/3C	Bolt, 2 BA ... ..						1	—	C.	
28D/11255	AS.1246/2C	Bolt, 2 BA ... ..						1	—	C.	
28M/12929	A27/CP	Nut, 2 BA ... ..						2	—	C.	
	12 N 2289	<b>BRACKET</b> , for emergency fuel pump switch...						1	—		
26FC/317	DHS.199	<b>TERMINAL</b> , earth ... ..						1	—	C.	
	ROTAX D.5507	<b>SWITCH</b> , camera test (Mod. Ven 167) ... ..						1	—	B.	
		Attaching parts for Air Ministry Ref. No. 5CW/4226, Switch :—									
28L/11067	AGS.2035/B	Lockwasher, 4 BA ... ..						4	—	C.	
28S/2857	A32/B12	Screw, 4 BA ... ..						4	—	C.	
	ROTAX D.5404	<b>SWITCH</b> , emergency fuel pump (Mod. Ven 703)						1	—	B.	
		Attaching parts for Air Ministry Ref. No. 5CW/4184, Switch :—									
28S/13887	A32/B10	Screw, 4 BA ... ..						2	—	C.	
	THERMAL CONTROL TP.5216	<b>SWITCH</b> , high pressure, 1.400 P.S.I. (Mod. Ven 560)						1	—	A.	
		Attaching parts for Air Ministry Ref. No. 5CW/5502, Switch :—									
28D/12513	A25/2C	Bolt, 2 BA ... ..						4	—	C.	
28W/12296	SP.15/C	Washer ... ..						4	—	C.	
	†	<b>UNIT</b> , control, type 382, TR.1934, Radio ...						1	—	A.	
		Attaching parts for 10L/246, Unit :—									
28D/11255	AS.1246/2C	Bolt, 2 BA ... ..						2	—	C.	
28D/12786	AS.1246/22C	Bolt, 2 BA ... ..						1	—	C.	
28M/10288	AGS.2001/C/1	Nut, 2 BA ... ..						3	—	C.	
		<b>VALVE</b> , selector, power (12-4S 73) ... ..						1	—		
		Consisting of :—									
9228	12-4S 13	<b>KNOB</b> , selector ... ..						1	—	C.	
9230	12-4S 15	<b>NUT</b> , retaining ... ..						1	—	C.	
9229	12-4S 27	<b>PIN</b> , retaining, special ... ..						1	—	C.	
	12-4S 19	<b>SHIM</b> , "Attewell" LA.3, 1/16" thick ... ..						1	—		
	12-4S 53A/ND	<b>VALVE</b> , selector, comprising ... ..						1	—		
27M/646	LOCKHEED AIR.42164	<b>VALVE</b> , selector ... ..						1	—	A.	
		(See AP.4515F, Vol. 3, Part 1, Sect. 2, Chap. 11 for breakdown)									

INSTRUMENT PANELS

Ref. No.	Part No.	Nomenclature						No. Off	M.R.	Cl. of St.	Plate No.
		1	2	3	4	5	6				
28F/10410 6503	AGS.1104/C 12 S 1315	Attaching parts for AIR.42164, Valve :— Adaptor, cone ... .. 2						2	—	C.	
		Union, cone, special reducing (Made from AGS.1107/J) ... .. 1						1	—	C.	
28F/11958	AGS.1186/C	Washer ... .. 3						3	—	C.	
28W/12731	SP.16/B	<b>WASHER</b> , spacer, between emergency fuel pump switch and bracket (Mod. Ven 703) ... .. 2						2	—	C.	
28D/12528	A25/1B	Attaching parts for 12-4F 53A/2, Panel :— Bolt, 4 BA ... .. 1						1	—	C.	
28D/11255	AS.1246/2C	Bolt, 2 BA ... .. 3						3	—	C.	
28D/11210	AS.1246/3C	Bolt, 2 BA ... .. 4						4	—	C.	
28M/10288	AGS.2001/C/1	Nut, 2 BA ... .. 7						7	—	C.	
28M/10287	AGS.2001/B/1	Nut, 4 BA ... .. 1						1	—	C.	
26FC/933	12 F 1079A/5 A.001098A	<b>PANEL</b> , R.H., complete with instruments ... .. 1						1	—	—	JE.1
		<b>ADAPTOR</b> , stowage ... .. 1						1	—	C.	JE.1
28M/12929	A27/CP	Attaching parts for A.001098A, Adaptor :— Nut, 2 BA ... .. 2						2	—	C.	
28S/2814	A33/C16	Screw, 2 BA ... .. 2						2	—	C.	
6A/2709	†	<b>ALTIMETER</b> , Mk. 18, cabin ... .. 1						1	—	A.	JE.1
28D/11210	AS.1246/3C	Attaching parts for 6A/2709, Altimeter :— Bolt, 2 BA ... .. 1						1	—	C.	
28D/11971	AS.1246/4C	Bolt, 2 BA ... .. 1						1	—	C.	
28M/10328	AGS.2002/C/1	Nut, 2 BA ... .. 2						2	—	C.	
26FC/6680	B.002525	<b>BRACKET</b> , mounting, for de-icing pump ... .. 1						1	—	C.	JE.1
28D/11255	AS.1246/2C	Attaching parts for B.002525, Bracket :— Bolt, 2 BA ... .. 5						5	—	C.	
28M/10288	AGS.2001/C/1	Nut, 2 BA ... .. 8						8	—	C.	
28S/2862	A32/C16	Screw, 2 BA ... .. 3						3	—	C.	
26FC/937	A.001122A	<b>CLAMP</b> , support ... .. 1						1	—	C.	JE.2
26FC/949	A.001120A	<b>BOLT</b> , trunnion ... .. 1						1	—	C.	JE.2
28M/802	AGS.113/C A.00119	<b>NUT</b> , 2 BA, wing ... .. 1						1	—	C.	
28P/836	SP.4Y/B10	<b>PIECE</b> , distance ... .. 1						1	—	—	JE.2
28P/12462	SP.9/C8	<b>PIN</b> , shackle for straps ... .. 2						2	—	C.	
26FC/950	A.001117A	<b>PIN</b> , split ... .. 2						2	—	C.	
26FC/951	A.001118A	<b>STRAP</b> , half ... .. 1						1	—	C.	JE.2
		<b>STRAP</b> , half ... .. 1						1	—	C.	JE.2
28M/10328	AGS.2002/C/1	Attaching parts for A.001122A, Clamp :— Nut, 2 BA ... .. 2						2	—	C.	
28S/2820	A33/C20	Screw, 2 BA ... .. 2						2	—	C.	

## INSTRUMENT PANELS

Ref. No.	Part No.	Nomenclature						No. Off	M.R.	Cl. of St.	Plate No.
		1	2	3	4	5	6				
26FC/938	A.001221							1	—	C.	JE.2
28M/12929	A27/CP							2	—	C.	
28S/2814	A33/C16							2	—	C.	
5L/X951273	†							1	—	B.	JE.1
6A/1862	†							1	—	A.	JE.1
28D/11210	AS.1246/3C							2	—	C.	
28M/10328	AGS.2002/C/1							2	—	C.	
6A/3863	GP.251/020							1	—	A.	JE.1
28D/8301	AS.1242/2B							4	—	C.	
10A/12954	†							1	—	B.	
5CZ/—	DOWTY C.1838Y Mk. 1							2	—	—	
5CZ/4361	† B.00948							2	—	B.	
								1	—	—	JE.1
5CX/1553	† 12 F 1077A/3							1	—	B.	JE.1
								1	—	—	JE.1
26FC/935	B.0054A							1	—	C.	
28D/11255	AS.1246/2C							2	—	C.	
28M/12929	A27/CP							2	—	C.	
26FC/317	DHS.199							1	—	C.	
	12 F 2117							1	—	—	
28D/11210	AS.1246/3C							2	—	C.	
28M/10288	AGS.2001/C/1							2	—	C.	
28W/12252	SP.13/C							2	—	C.	
	12 N 1355							1	—	—	JE.1
28S/3426	A32/B8							2	—	C.	
27F/2162	M.2601 ROTAX							1	—	A.	JE.1
28D/11937	AS.1246/1B							3	—	C.	
28M/10287	AGS.2001/B/1							3	—	C.	

INSTRUMENT PANELS

Ref. No.	Part No.	Nomenclature						No. Off	M.R.	Cl. of St.	Plate No.
		1	2	3	4	5	6				
5CW/4676	TEDDINGTON FJB/A/4	<b>SWITCH</b> , selector ... ..						1	—	A.	JE.1
28D/12948	AS.1246/3B	Attaching parts for FJB/A/4, Switch :— Bolt, 4 BA ... ..						2	—	C.	
28M/10287	AGS.2001/B/1	Nut, 4 BA ... ..						2	—	C.	
28W/12305	SP.13/B	Washer ... ..						2	—	C.	
5CW/—	TEDDINGTON FJB/A/2	<b>SWITCH</b> , selector (Alternative to FJB/A/4, Switch)						1	—	—	
28F/12425	AGS.1109/K	<b>UNION</b> , reducing, for windscreen de-icing pump						1	—	C.	
28F/8225	AGS.1138/A	<b>WASHER</b> , jointing, for windscreen de-icing pump						2	—	C.	
28D/12528	A25/1B	Attaching parts for 12 F 1079A/5, Panel :— Bolt, 4 BA ... ..						1	—	C.	
28D/11255	AS.1246/2C	Bolt, 2 BA ... ..						6	—	C.	
28M/10287	AGS.2001/B/1	Nut, 4 BA ... ..						6	—	C.	
28M/10288	AGS.2001/C/1	Nut, 2 BA ... ..						1	—	C.	
	12 F 1061A/1	<b>PANEL</b> , top centre, complete with instruments (Pre Mod. Ven 751)						1	—	—	JE.1
5L/X951230	†	<b>FILAMENT</b> , for undercarriage warning lamp, 24 volt, 2.8 watt, clear						1	—	B.	JE.1
26FC/4327	B.00375A/2	<b>LABEL</b> , " Tail trim " ... ..						1	—	C.	JE.1
26FC/946	B.00252	<b>LABEL</b> , " Undercarriage Warning " ... ..						1	—	C.	JE.1
28M/10286	AGS.2001/A/1	Attaching parts for B.00252, Label :— Nut, 6 BA ... ..						2	—	C.	
28S/2858	A32/A12	Screw, 6 BA ... ..						2	—	C.	
5CX/1553	†	<b>LAMP</b> , undercarriage warning ... ..						1	—	B.	JE.1
	12 F 1239	<b>PANEL</b> , less instruments ... ..						1	—	—	JE.1
	B.00357ND	<b>STRIP</b> , 1/4" x 1/4" x 1.5" long, LFS.23 ... ..						1	—	—	JE.1
	12 F 1125ND	<b>STRIP</b> , 1/4" x 1/4" x 1.0" long, LFS.23 ... ..						1	—	—	JE.1
		Attaching parts for B.00357ND and 12 F 1125ND, Strips :—									
28M/13288	A27/AP	Nut, 6 BA ... ..						2	—	C.	
28S/2870	A32/A20	Screw, 6 BA ... ..						2	—	C.	
26FC/317	DHS.199	<b>TERMINAL</b> , earth ... ..						1	—	C.	
28D/11971	AS.1246/4C	Attaching parts for 12 F 1061A/1, Panel :— Bolt, 2 BA ... ..						1	—	C.	
28D/11890	AS.1246/5C	Bolt, 2 BA ... ..						1	—	C.	
28M/10288	AGS.2001/C/1	Nut, 2 BA ... ..						2	—	C.	

INSTRUMENT PANELS

Ref. No.	Part No.	Nomenclature						No. Off	M.R.	Cl. of St.	Plate No.
		1	2	3	4	5	6				
	12 F 2143A	<b>PANEL</b> , top centre, complete with instruments (Mod. Ven 751) (Pre Mod. Ven 780)						1	—		
	12 F 1987A	<b>BRACKET</b> , for clock ... ..						1	—		
28D/13283	A28/2C	Attaching parts for 12 F 1987A, Bracket :—									
28W/12296	SP.15/C	Bolt, 2 BA ... ..						3	—	C.	
		Washer ... ..						3	—	C.	
6A/3157	†	<b>CLOCK</b> , type V.308 ... ..						1	—	A.	
		Attaching parts for Air Ministry Ref. No. 6A/3157, Clock :—									
28D/15211	AS.4565/2B	Bolt, 4 BA ... ..						4	—	C.	
5L/X951273	†	<b>FILAMENT</b> , for undercarriage warning light, 28 volt, 3.5 watt, clear						1	—	B.	
5CX/1553	†	<b>LAMP</b> , undercarriage warning ... ..						1	—	B.	
	12 F 2141A	<b>PANEL</b> , less instruments ... ..						1	—		
	B.00357ND	<b>STRIP</b> , 1/8" x 1/8" x 1.5" long, LFS.23 ... ..						1	—		
	12 F 1125ND	<b>STRIP</b> , 1/8" x 1/8" x 1.0" long, LFS.23 ... ..						1	—		
		Attaching parts for B.00357ND and 12 F 1125ND, Strips :—									
28M/10286	AGS.2001/A/1	Nut, 6 BA ... ..						2	—	C.	
28S/2876	A32/A24	Screw, 6 BA ... ..						2	—	C.	
26FC/317	DHS.199	<b>TERMINAL</b> , earth ... ..						1	—	C.	
		Attaching parts for 12 F 2143A, Panel :—									
28D/11971	AS.1246/4C	Bolt, 2 BA ... ..						1	—	C.	
28D/13283	A28/2C	Bolt, 2 BA ... ..						1	—	C.	
28M/10288	AGS.2001/C/1	Nut, 2 BA ... ..						1	—	C.	
28W/12296	SP.15/C	Washer ... ..						1	—	C.	
	12 F 2211A	<b>PANEL</b> , top centre, complete with instruments (Mod. Ven 780)						1	—		
	12 F 1987A	<b>BRACKET</b> , for clock ... ..						1	—		
28D/13283	A28/2C	Attaching parts for 12 F 1987A, Bracket :—									
28W/12296	SP.15/C	Bolt, 2 BA ... ..						3	—	C.	
		Washer ... ..						3	—	C.	
6A/3157	†	<b>CLOCK</b> , type V.308 ... ..						1	—	A.	
		Attaching parts for Air Ministry Ref. No. 6A/3157, Clock :—									
28D/15211	AS.4565/2B	Bolt, 4 BA ... ..						4	—	C.	





J.2.

# FUSELAGE

## FUSELAGE COMPLETE

RESTRICTED

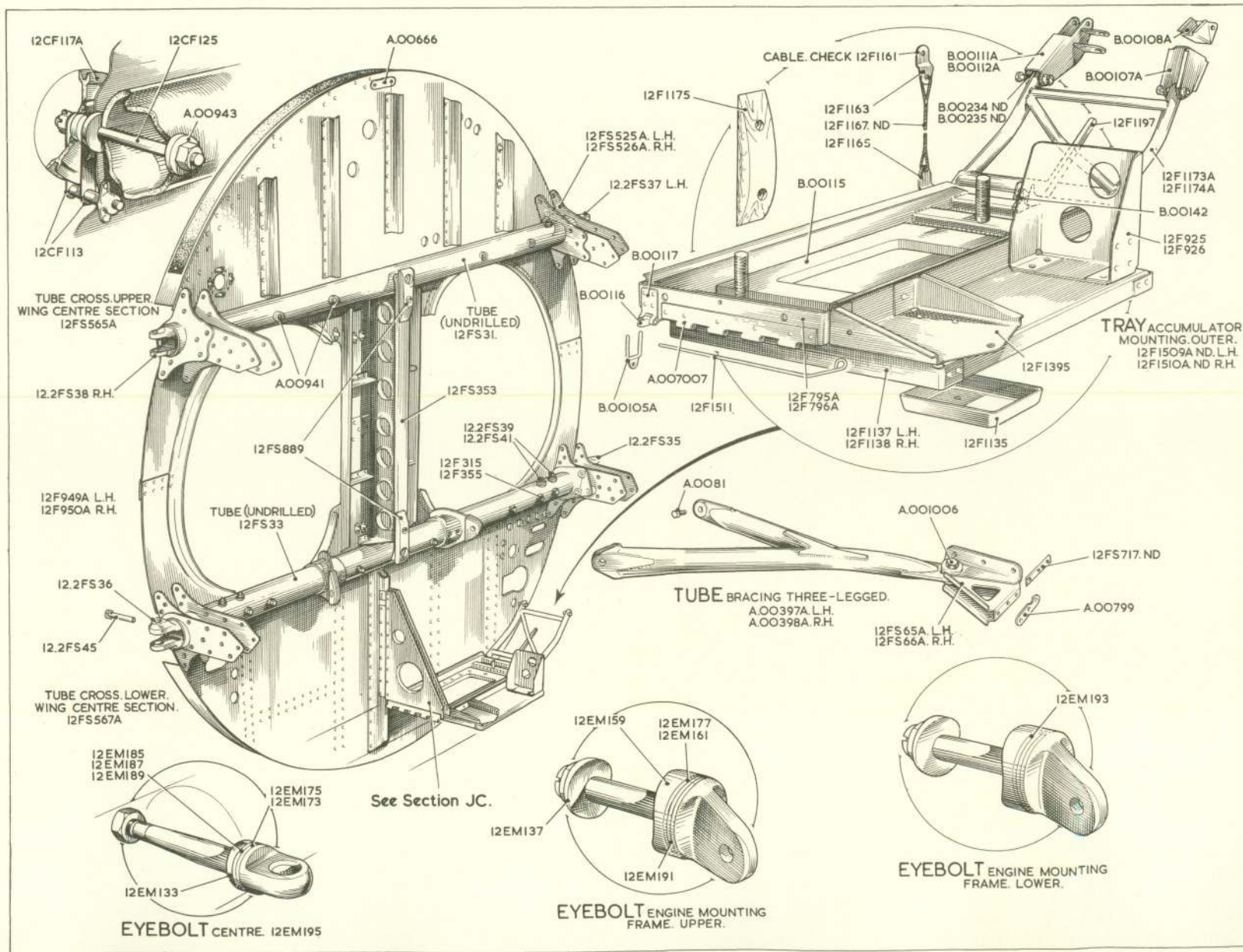

Venom FB Mk. 4

RESTRICTED

Plate J2

J.2.

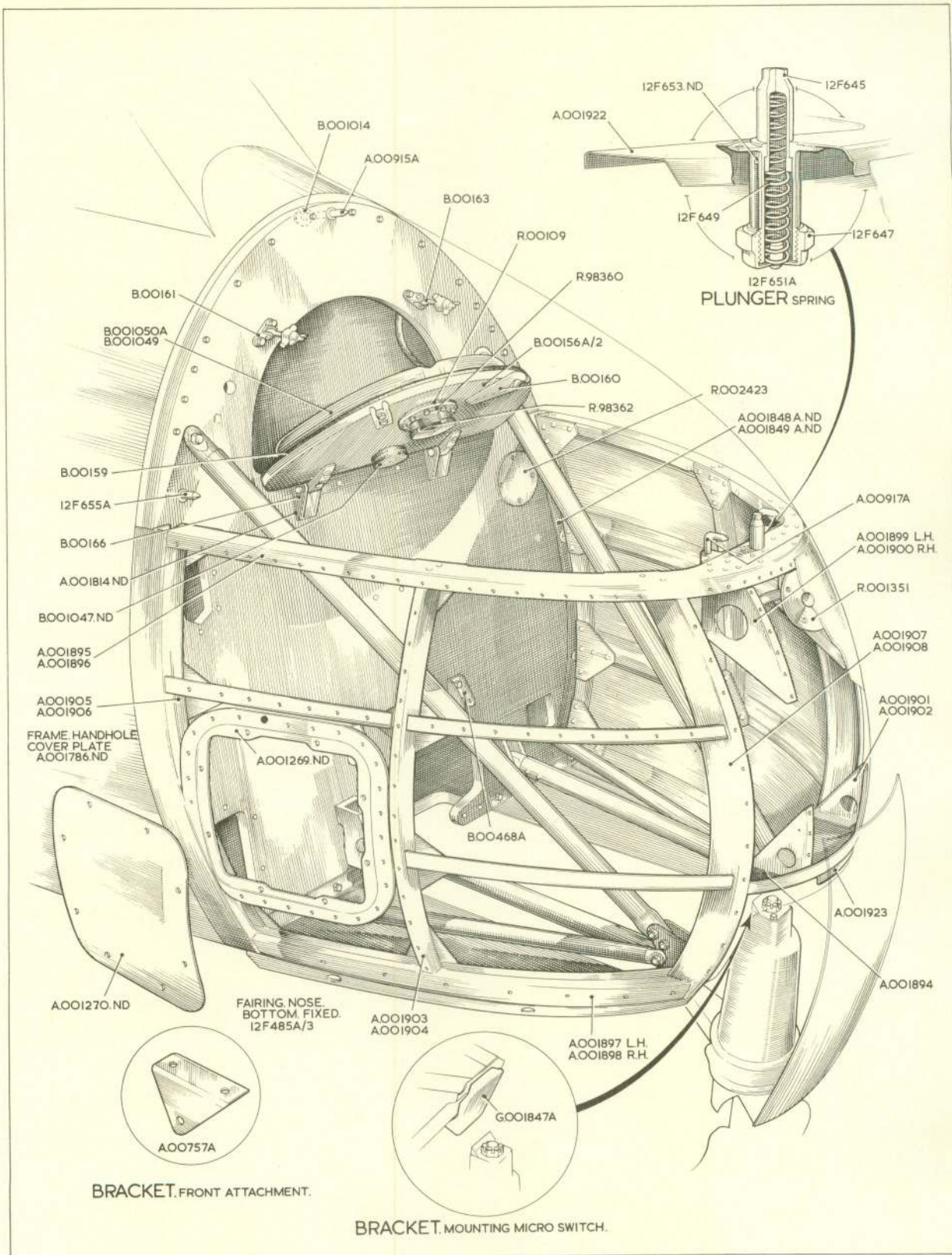

J.3.

# FUSELAGE

J.3.

## FUSELAGE COMPLETE

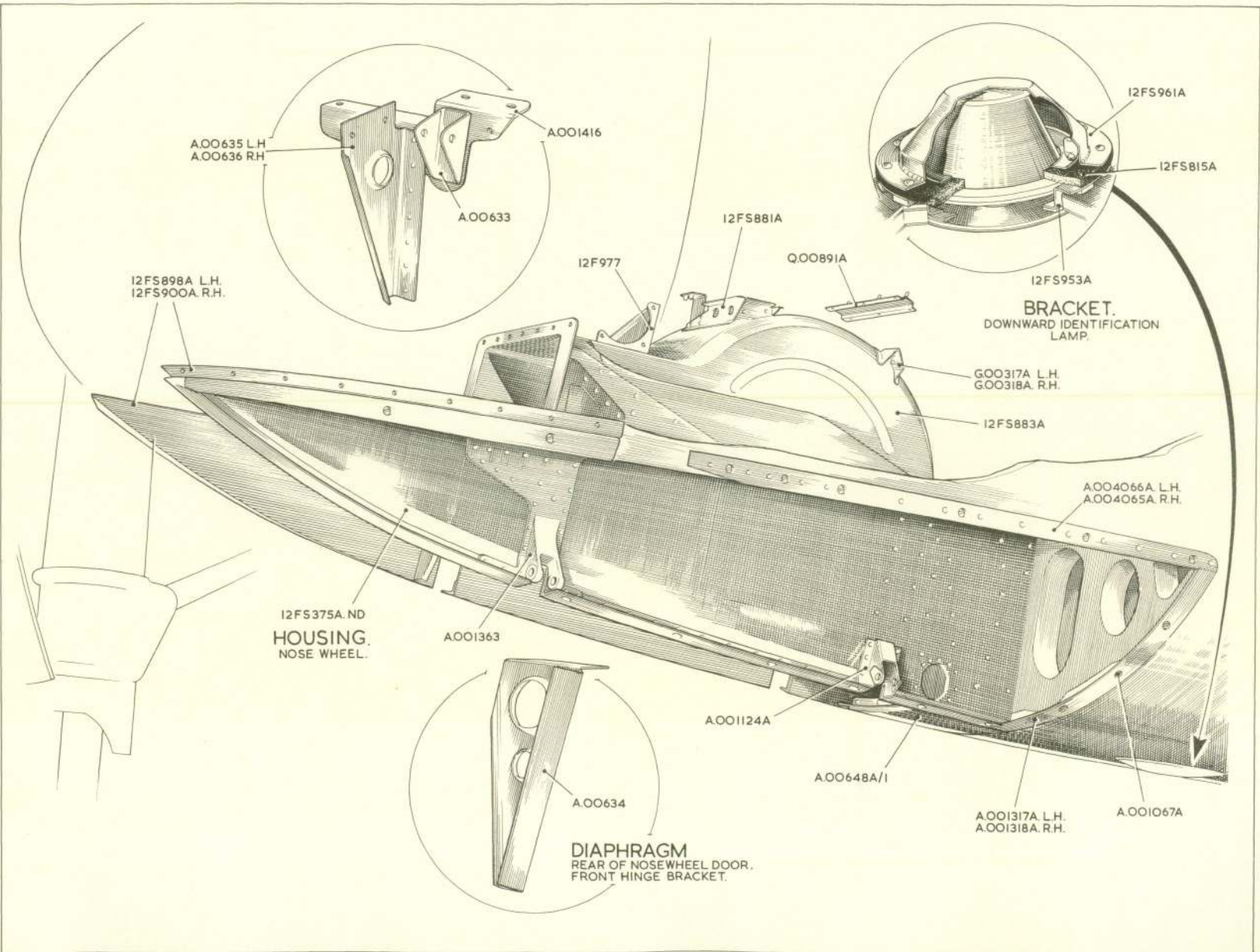

J.4.

FUSELAGE

FUSELAGE COMPLETE

RESTRICTED

J.4.

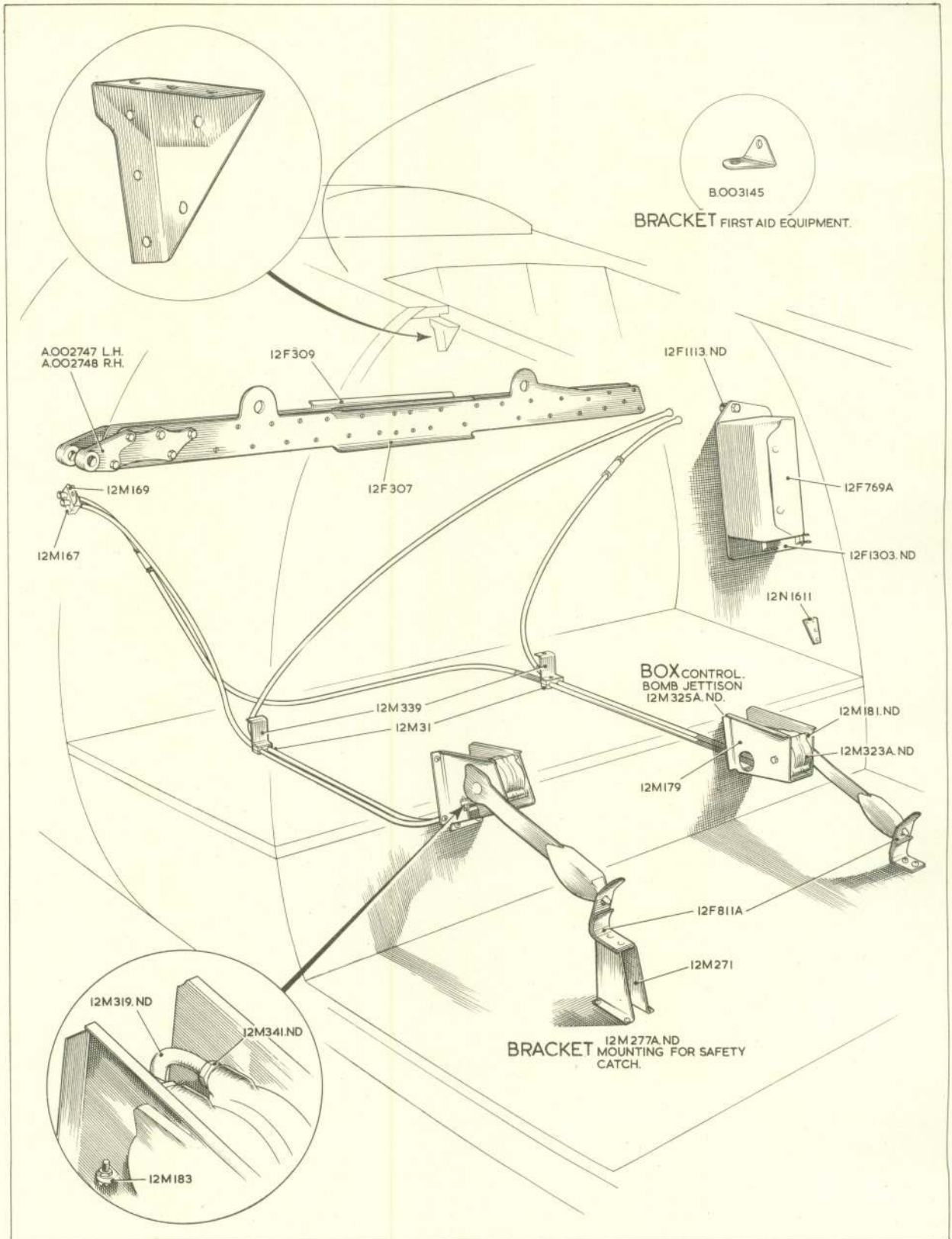

J.5.

# FUSELAGE

J.5.

## FUSELAGE COMPLETE

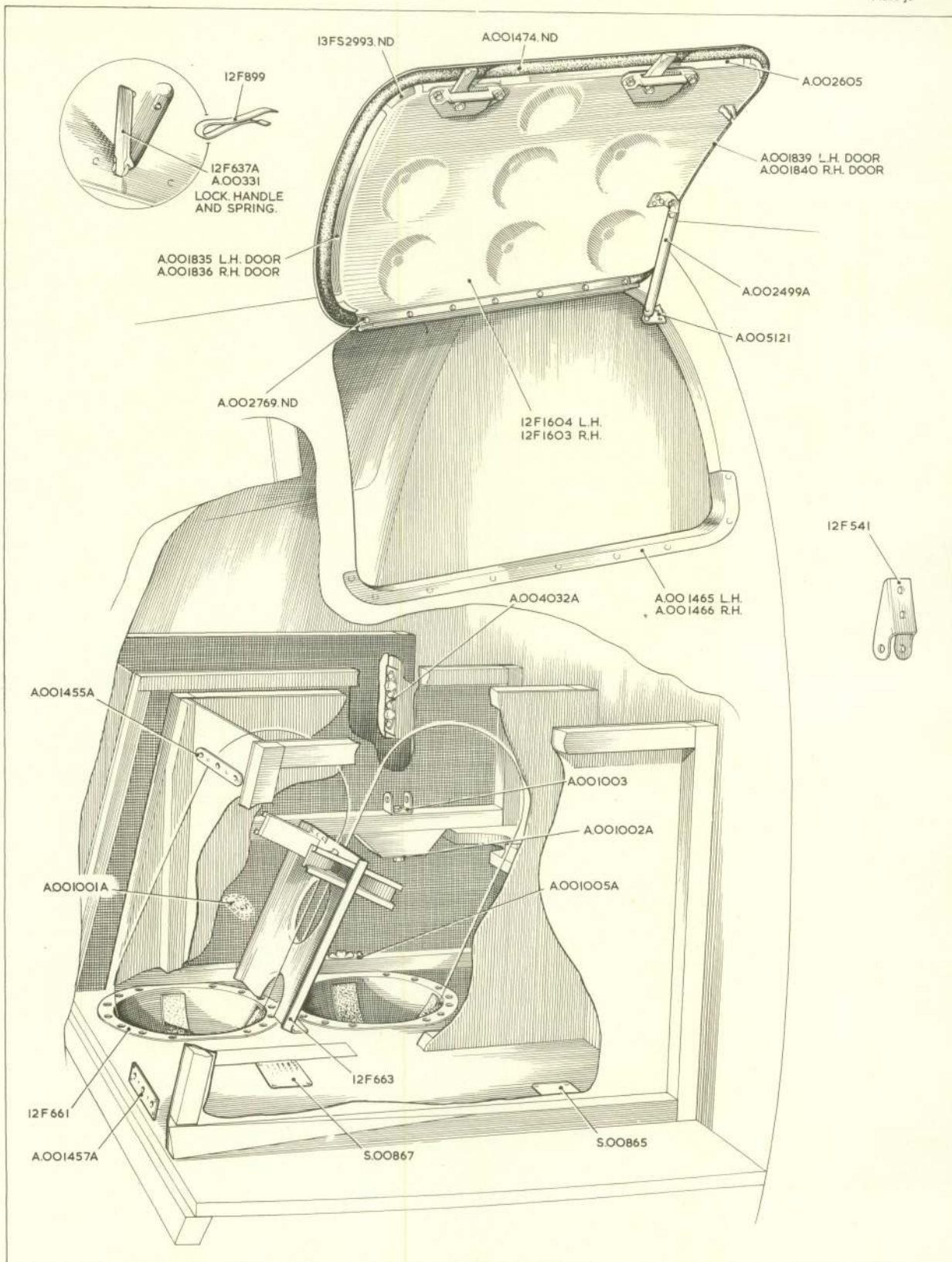

J.6.

# FUSELAGE

J.6.

## FUSELAGE COMPLETE

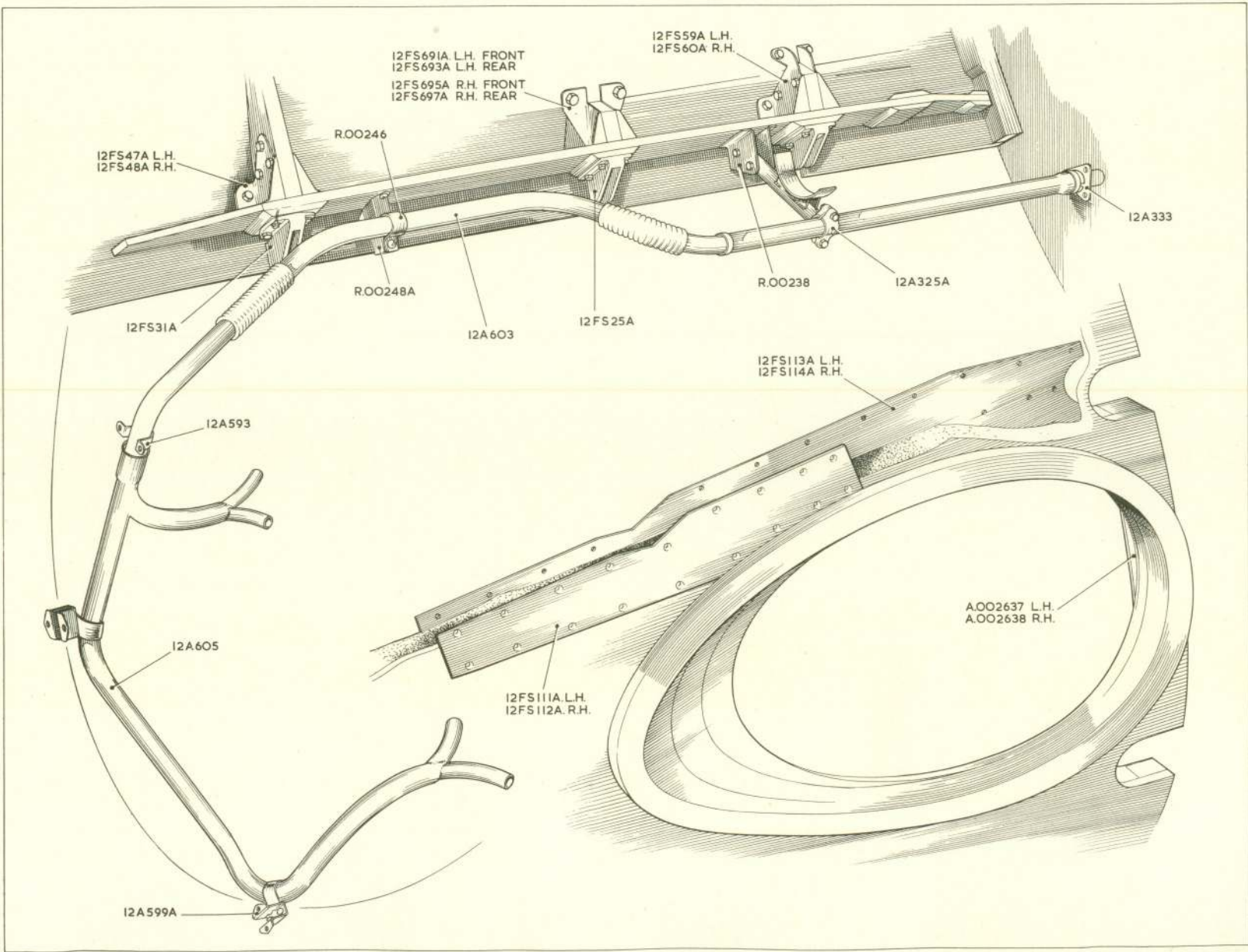

J7.

FUSELAGE

FUSELAGE COMPLETE

RESTRICTED

J7.

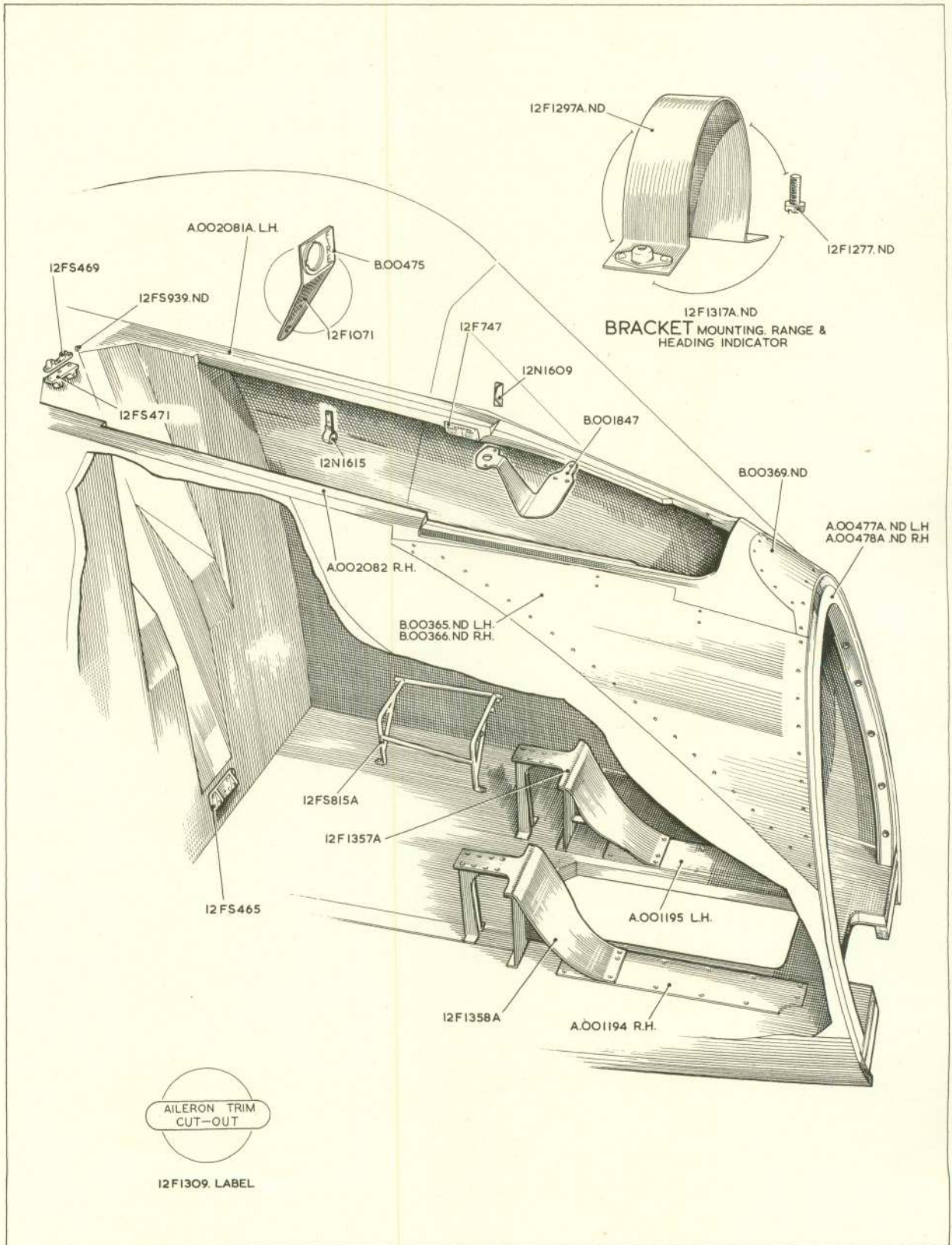

J.8.

# FUSELAGE

J.8.

## FUSELAGE COMPLETE

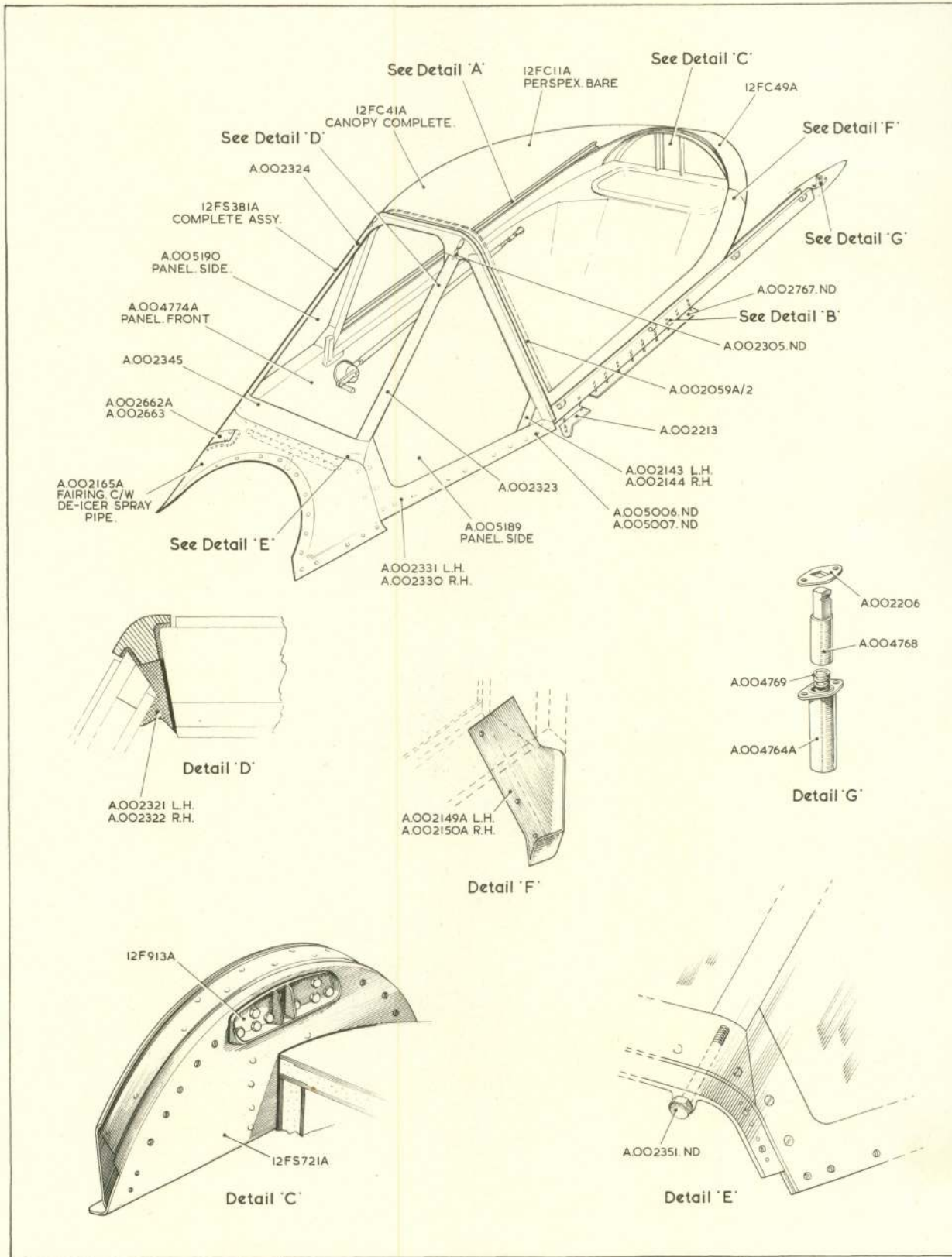

JA.1.

**FUSELAGE**  
**COCKPIT CANOPY**

JA.1.

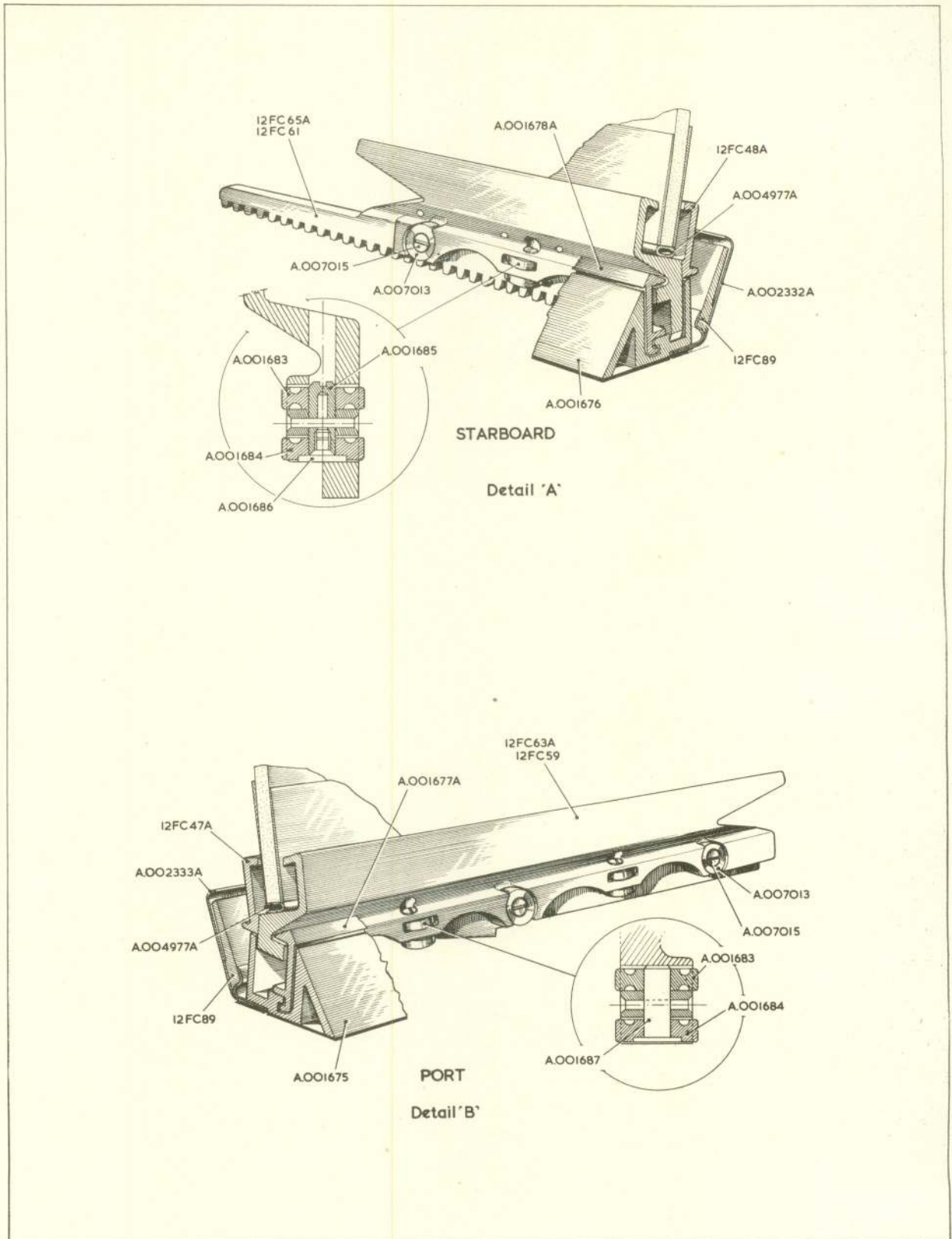

JA.2.

**FUSELAGE**  
**COCKPIT CANOPY**

JA.2.

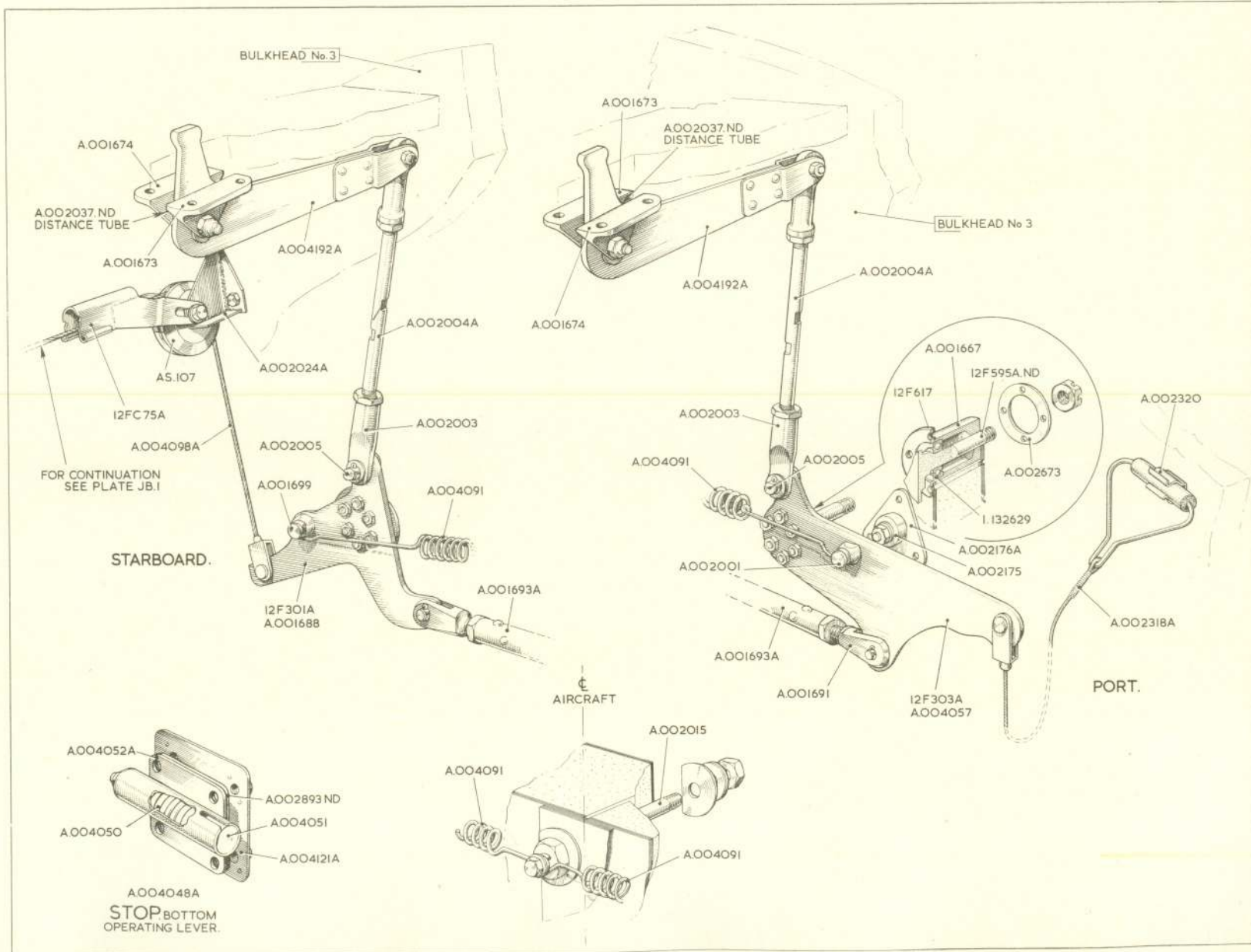

JB.1.

FUSELAGE  
COCKPIT CANOPY  
JETTISON AND WINDING GEAR

RESTRICTED

JB.1.

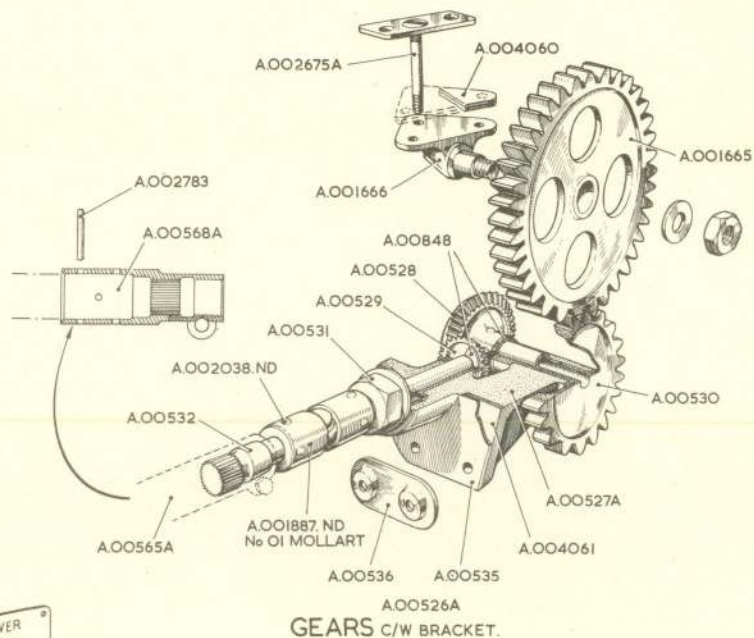
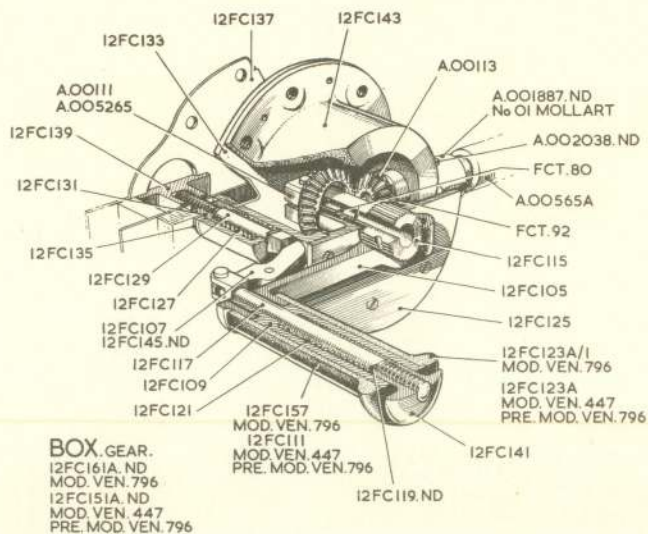

IMPORTANT. CABIN BLOWER  
MUST BE OFF AND CABIN  
PRESSURE ZERO BEFORE  
OPENING OR CLOSING CANOPY

A.OO1104

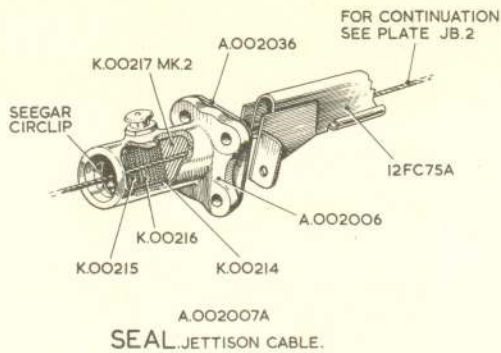
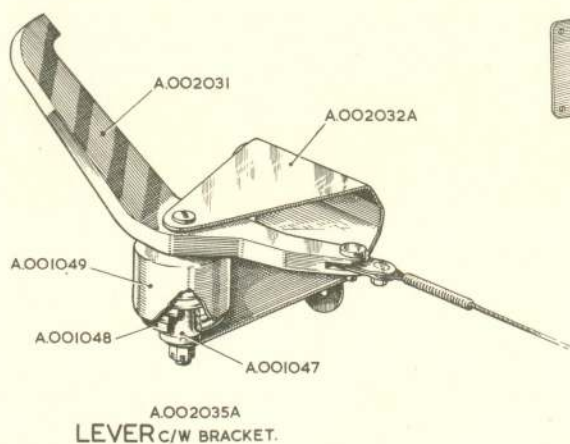

JB.2.

FUSELAGE  
COCKPIT CANOPY  
AND WINDING GEAR

RESTRICTED

JB.2.

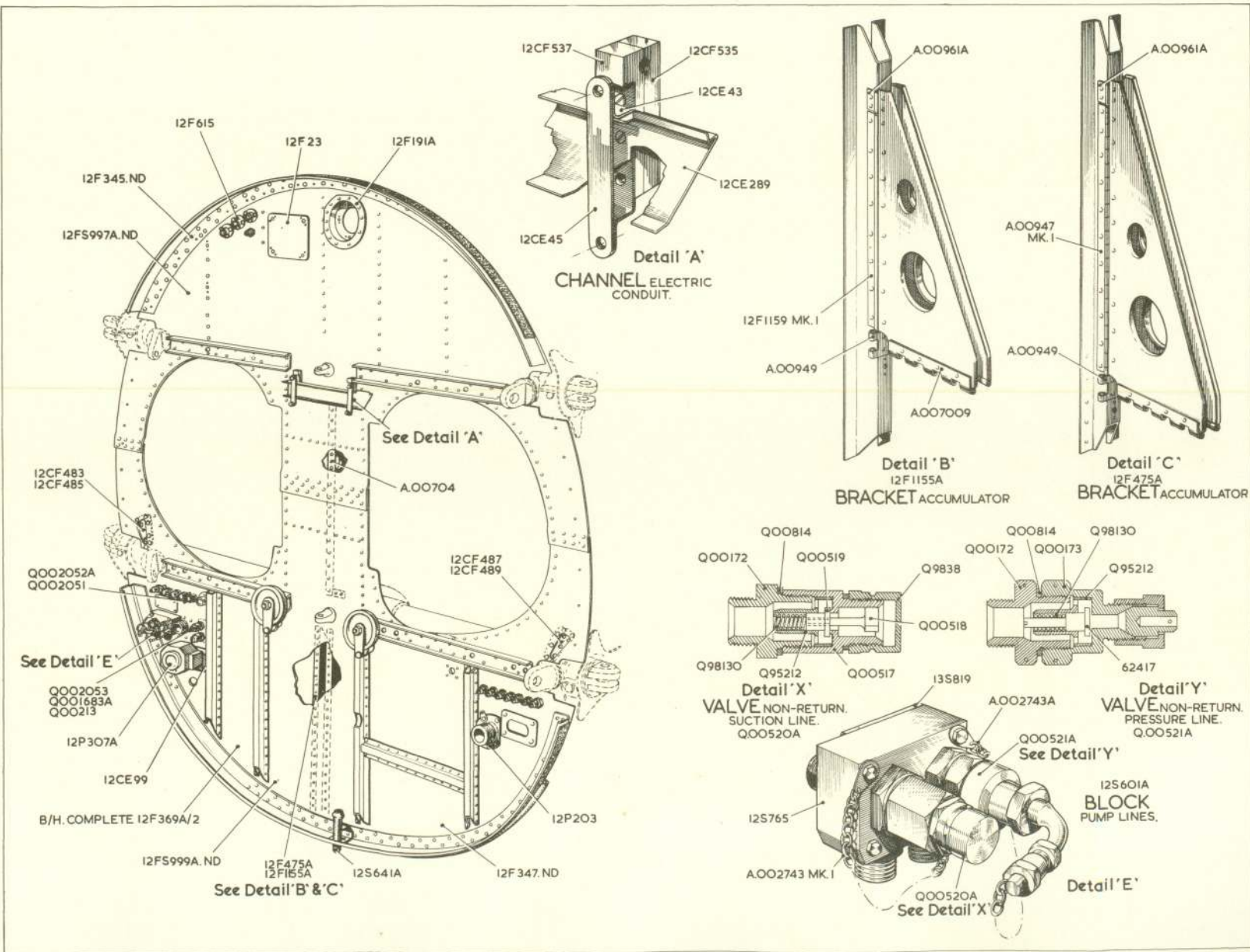

JC1

**FUSELAGE  
FIREPROOF BULKHEAD AND  
ACCESSORIES**

JC1.

RESTRICTED

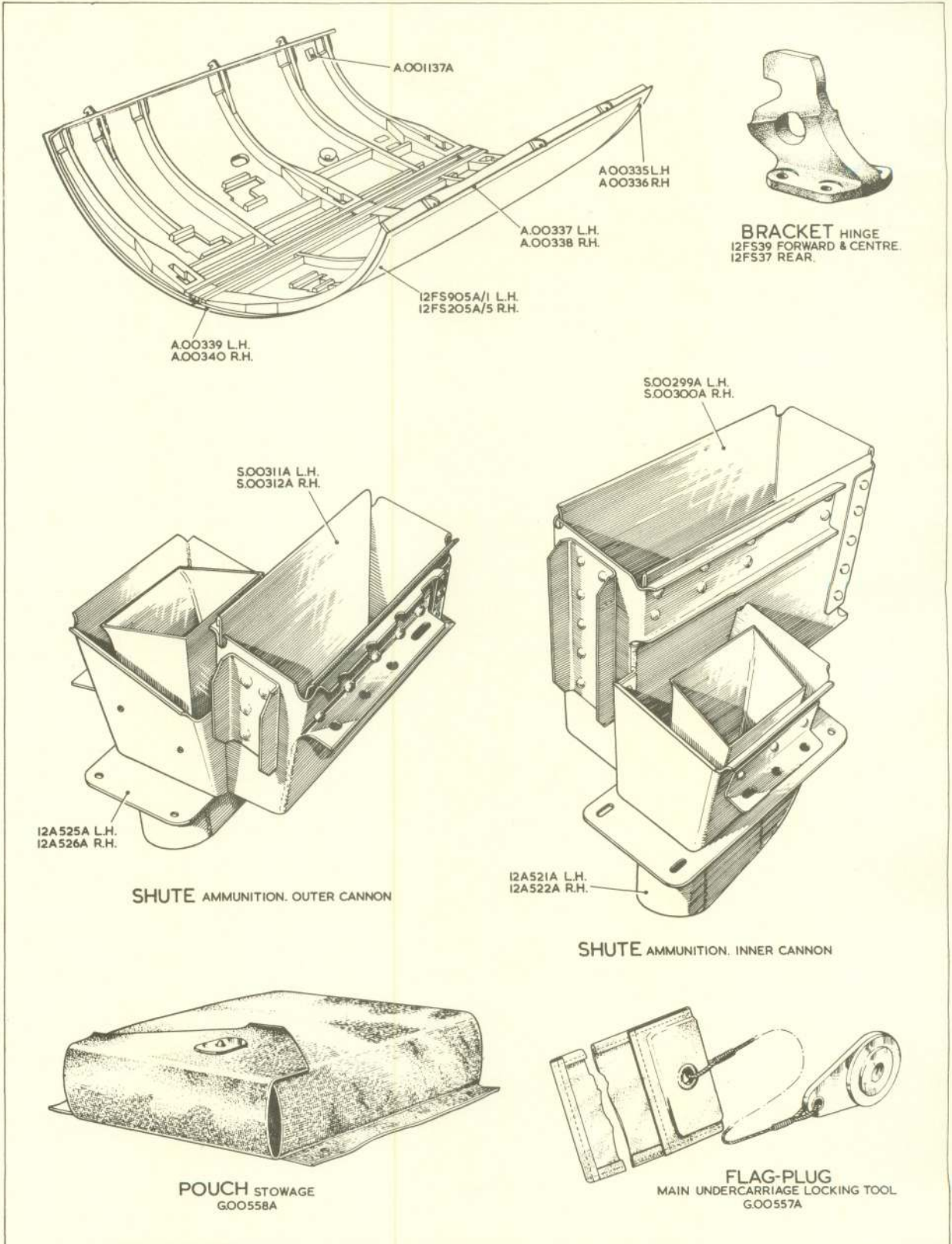

JD.1.

# FUSELAGE GUN BAY DOORS

JD.1.

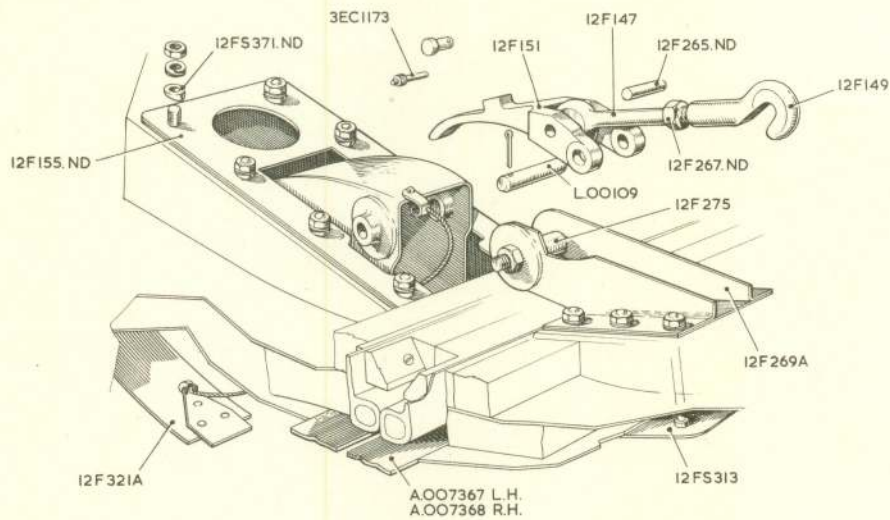

FASTENER TOGGLE I2F135A

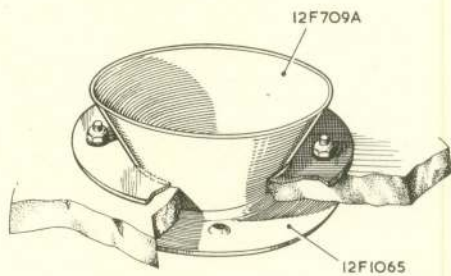
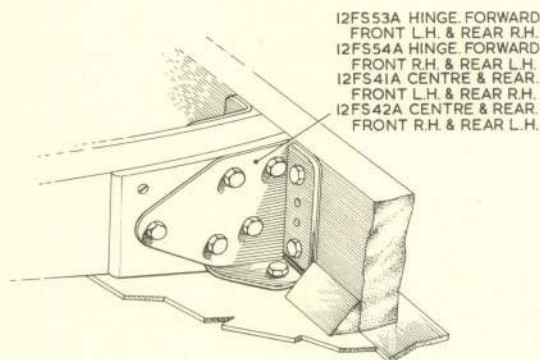
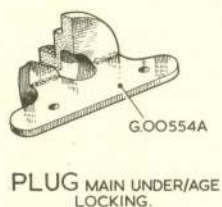

JE1.

# FUSELAGE

## INSTRUMENT PANELS

RESTRICTED

JE1.

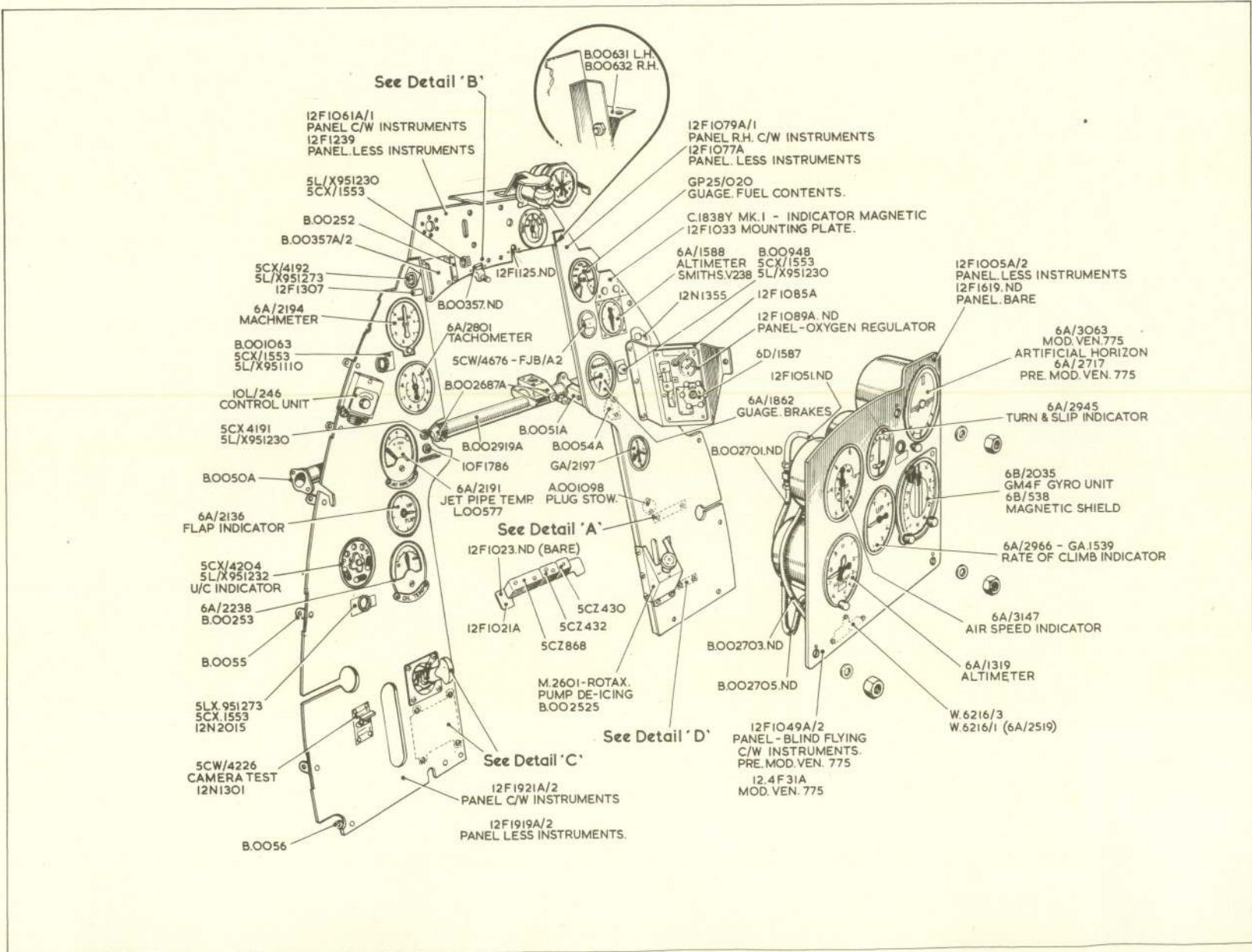

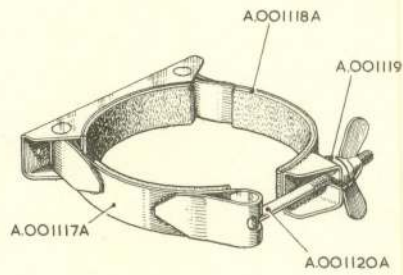

A.OO1122A  
CLAMP AIR DRIER  
Detail 'A'

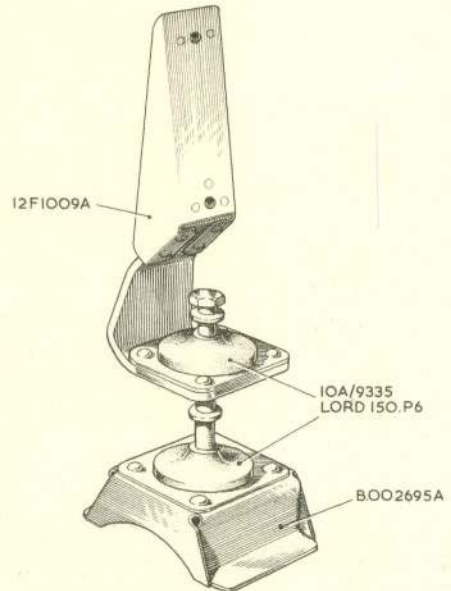

MOUNTING ANTI-VIBRATION.  
Detail 'B'

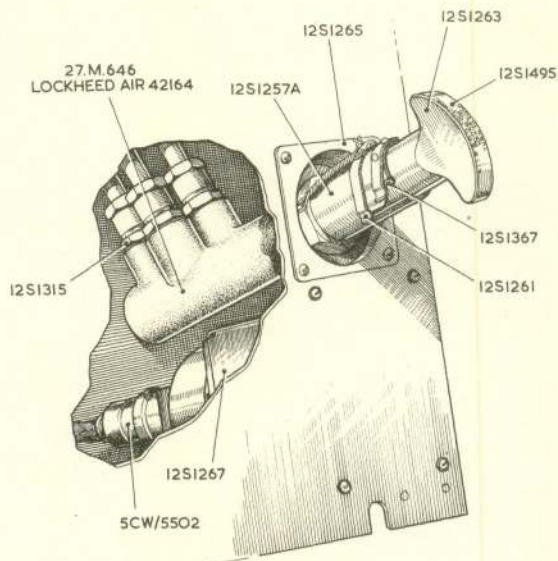

I2S1501A, ND  
Detail 'C'  
VALVE SELECTOR

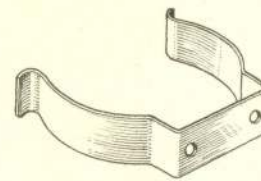

A.OO1221  
CLIP AIR DRIER  
Detail 'D'

JE.2.

# FUSELAGE

JE.2.

## INSTRUMENT PANELS

## HAND INK ALTERATIONS

Insert in the "Plate No." Column the following plate numbers against the undermentioned Part Numbers :—

## PAGE J.1

Ref. No.	Part No.	Plate No.	Ref. No.	Part No.	Plate No.
1302	12 A 333A	J.1	1558	12 F 864A	J.1
	12 M 169	J.5	1559	12 F 865A	J.1
9723	12 F 1631A	J.1	1560	12 F 866A	J.1
9724	12 F 1632A	J.1		A.001849/AND	J.3
725	12 F 545A	J.1		A.001848A/ND	J.3
726	12 F 546A	J.1	26FC/1822	A.001317A	J.4
727	12 F 549A	J.1	26FC/1823	A.001318A	J.4
728	12 F 550A	J.1	26FC/1824	A.0010667A	J.4
1557	12 F 863A	J.1	6037	12 F 827ND	J.1

## PAGE J.2

Ref. No.	Part No.	Plate No.	Ref. No.	Part No.	Plate No.
26FC/4646	A.001953A/1	J.1	7719	12 M 31	J.5
26FC/4647	A.001954A/2	J.1		12 F 835	J.1
7723	12 N 167	J.5			

## PAGE J.3

Ref. No.	Part No.	Plate No.	Ref. No.	Part No.	Plate No.
	12 M 325A/ND	J.5	1678	12 M 183	J.5
	12 M 323A/ND	J.5		12 M 181ND	J.5
	12 M 341ND	J.5		A.005121	J.6
	12 M 319ND	J.5	26FC/4881	B.003145	J.5
1677	12 M 179	J.5	26FC/1739	R.00248A	J.7

## PAGE J.4

Ref. No.	Part No.	Plate No.	Ref. No.	Part No.	Plate No.
26FC/1738	R.00238	J.7	1655	12 FS 471	J.8
6072	12 A 599A	J.7		12 F 1357A	J.8
1657	12 FS 465	J.7		12 F 1358A	J.8
1656	12 FS 469	J.8		12 N 1609	J.8
			26FC/1927	B.00161	J.3

## PAGE J.5

Ref. No.	Part No.	Plate No.	Ref. No.	Part No.	Plate No.
26FC/1855	B.00107A	J.2	8122	12 M 277A/ND	J.5
26FC/1856	B.00108A	J.2	1688	12 M 271	J.5
594	12 FS 25A	J.7	1144	12 F 811A	J.5
595	12 FS 31A	J.7	26FC/1857	B.00111A	J.2
	12 N 1611	J.5	26FC/1858	B.00112A	J.2
2900	12 FS 953A	J.4		A.001003	J.6
26FC/4604	B.001847	J.8			

## PAGE J.6

Ref. No.	Part No.	Plate No.	Ref. No.	Part No.	Plate No.
	A.002747	J.5	26FC/5372	G.001847A	J.3
	A.002748	J.5	26FC/4359	A.005291	J.1
9030	12 FS 65A	J.2	8116	12 FS 691A	J.7
9031	12 FS 66A	J.2	8118	12 FS 695A	J.7
	12 FS 717ND	J.2	8117	12 FS 693A	J.7
			8119	12 FS 697A	J.7

RESTRICTED

PART 1

Venom FB Mk. 4

Issued with AL/2

HAND INK ALTERATIONS

Insert in the "Plate No." Column the following plate numbers against the undermentioned Part Numbers :-

PAGE J.7

Ref. No.	Part No.	Plate No.	Ref. No.	Part No.	Plate No.
26FC/3049	B.00468A	J.3	739	12 F 541A	J.6
	12 M 339	J.5	8113	12 FS 59A	J.7
2181	12 FS 47A	J.7	8114	12 FS 60A	J.7
2182	12 FS 48A	J.7		A.0021A/1	J.1

PAGE J.8

Ref. No.	Part No.	Plate No.	Ref. No.	Part No.	Plate No.
26FC/1954	A.001465/1	J.6	26FC/1899	A.001474ND	J.6
26FC/1955	A.001466/1	J.6	26FC/3752	A.002499A	J.6
26FC/2729	A.001839	J.6	1301	12 A 325A	J.7
26FC/2730	A.001840	J.6		R.00246	J.7
			7100	12 A 593ND	J.7

PAGE J.9

Ref. No.	Part No.	Plate No.	Ref. No.	Part No.	Plate No.
1666	12 F 661	J.6	26FC/3008	A.002605	J.6
	12 F 1603A	J.6	26FC/1895	A.001835	J.6
	12 F 1605A	J.6	26FC/1900	A.001836	J.6
1008	12 F 637A	J.6	26FC/1551	B.00156A/2	J.3
	A.00331	J.6	26FC/3510	B.00160	J.3
	A.002769	J.6		B.001050A	J.3
1448	12 F 899	J.6	26FC/1906	R.98360	J.3
	13 FS 2993ND	J.6			

PAGE J.10

Ref. No.	Part No.	Plate No.	Ref. No.	Part No.	Plate No.
26FC/1907	R.00109	J.3	1905	12 EM 187	J.2
	B.001047ND	J.3	1906	12 EM 189	J.2
26FC/1908	B.00159	J.3	570	12 EM 161	J.2
26FC/4655	R.98362	J.3	1203	12 EM 177	J.2
26FC/3554	B.001049	J.3	566	12 EM 137	J.2
6669	12 FS 905A/1	J.1	569	12 EM 159	J.2
6667	12 FS 205A/5	J.1	26FC/5400	A.00891A/2	J.1
1021	12 EM 173	J.2	1153	12 F 723A	J.1
1022	12 EM 175	J.2	7201	12 F 485A/3	J.3
565	12 EM 133	J.2	26FC/838	A.001923	J.3
1904	12 EM 185	J.2			

PAGE J.11

Ref. No.	Part No.	Plate No.	Ref. No.	Part No.	Plate No.
26FC/839	A.001894	J.3	26FC/851	A.001269ND	J.3
26FC/841	A.001899	J.3	26FC/853	A.00917A	J.3
26FC/842	A.001900	J.3	26FC/885	A.001270ND	J.3
26FC/843	A.001901	J.3	26FC/854	A.001922	J.3
26FC/844	A.001902	J.3	1093	12 F 651A	J.3
26FC/847	A.001903	J.3	1097	12 F 647	J.3
26FC/848	A.001904	J.3	1096	12 F 645	J.3
26FC/845	A.001907	J.3		12 F 653ND	J.3
26FC/846	A.001908	J.3	1095	12 F 649	J.3

## HAND INK ALTERATIONS

Insert in the "Plate No." Column the following plate numbers against the undermentioned Part Numbers :—

## PAGE J.11

Ref. No.	Part No.	Plate No.	Ref. No.	Part No.	Plate No.
26FC/849	A.001895	J.3	26FC/861	A.001897	J.3
26FC/850	A.001896	J.3	26FC/862	A.001898	J.3
	R.001351A	J.3	26FC/859	A.001905	J.3
	A.001786A/ND	J.3	26FC/860	A.001906	J.3

## PAGE J.12

Ref. No.	Part No.	Plate No.	Ref. No.	Part No.	Plate No.
1867	12 FS 883A	J.4	26FC/1922	B.00142	J.2
	12 FS 881A	J.4		B.00234ND	J.2
26FC/1915	G.00317A	J.4		B.00235ND	J.2
26FC/1916	G.00318A	J.4	26FC/817	A.001308A	J.1
1868	12 F 977	J.4	2901	12 FS 961A	J.4
26FC/3036	Q.00891A	J.4	26FC/7157	B.00166	J.3
26FC/1912	A.00799	J.2		A.001814ND	J.3
	12 F 1173A	J.2	26FC/4078	B.002595A	J.1
	12 F 1174A	J.2	458	12 FS 375A/ND	J.4
	12 F 1197	J.2	26FC/1853	A.001363	J.4
			26FC/1848	A.00633	J.4

## PAGE J.13

Ref. No.	Part No.	Plate No.	Ref. No.	Part No.	Plate No.
26FC/1852	A.001124A	J.4	8319	12 FS 899A	J.4
26FC/1854	A.001416	J.4	8320	12 FS 900A	J.4
26FC/1889	A.00635	J.4		12 F 1309	J.8
26FC/1890	A.00636	J.4		S.00865	J.6
26FC/1888	A.00634	J.4		S.00867	J.6
26FC/4322	A.00648A/1	J.4		12 F 747	J.8
			1799	12 FS 815A	J.8

## PAGE J.14

Ref. No.	Part No.	Plate No.	Ref. No.	Part No.	Plate No.
	A.002637	J.7	6071	12 A 603	J.7
	A.002638	J.7	26FC/2880	B.00369ND	J.8
	A.002471A	J.1	26FC/2878	B.00365ND	J.8
1094	12 F 655A	J.3	26FC/2879	B.00366ND	J.8
26FC/10300	A.00915A	J.3		B.00657	J.1
	B.001014	J.3		R.002423	J.3
6060	12 A 605A	J.7		B.00658	J.1

## PAGE J.15

Ref. No.	Part No.	Plate No.	Ref. No.	Part No.	Plate No.
1665	12 F 663A	J.6		A.004032A	J.6
	12 F 769A	J.5		12 FS 113A	J.7
	12 F 1303ND	J.5		12 FS 114A	J.7
	12 F 1113ND	J.5		12 FS 111A	J.7
	A.001457A	J.6		12 FS 112A	J.7
	A.001455A	J.6		12 F 307	J.5
26FC/1949	A.001005A	J.6		12 F 309	J.5
26FC/1948	A.001002A	J.6	574	12 FS 353	J.2
26FC/1947	A.001001A	J.6		A.00666	J.2

## HAND INK ALTERATIONS

Insert in the "Plate No." Column the following plate numbers against the undermentioned Part Numbers :—

## PAGE J.16

Ref. No.	Part No.	Plate No.	Ref. No.	Part No.	Plate No.
8115	12 FS 459	J.1	26FC/2876	A.002082A	J.8
576	12 CF 117A	J.2		12 F 1175	J.2
577	12 CF 125A	J.2	26FC/1970	A.00477A/ND	J.8
26FC/2875	A.002081A	J.8	26FC/1971	A.00478A/ND	J.8
			26FC/1831	A.00943	J.2

## PAGE J.17

Ref. No.	Part No.	Plate No.	Ref. No.	Part No.	Plate No.
26FC/1968	A.00259A/ND	J.1	26FC/815	A.001309A	J.1
26FC/1969	A.00260A/ND	J.1	26FC/818	A.001313A	J.1
26FC/1966	A.00257A/ND	J.1	26FC/3095	A.001307A/1	J.1
26FC/1964	A.00255A/ND	J.1	26FC/821	A.001311	J.1
26FC/1965	A.00256A/ND	J.1	26FC/820	A.001310	J.1
	A.005022A/ND	J.1	26FC/3096	A.001306A/1	J.1
26FC/814	A.001305A	J.1	26FC/3078	A.004066A	J.4
32A/106	†	J.1	26FC/3079	A.004065A	J.4
26FC/822	A.001315	J.1	26FC/1919	A.001195	J.8
			26FC/1977	A.001194	J.8

## PAGE J.18

Ref. No.	Part No.	Plate No.	Ref. No.	Part No.	Plate No.
	12 F 1509A/ND	J.2		12 F 796A	J.2
	12 F 1510A/ND	J.2		A.007007	J.2
	12 F 925	J.2	26FC/1982	B.00117	J.2
	12 F 926	J.2	26FC/1983	B.00116	J.2
	12 F 1161A	J.2		12 F 1137	J.2
	12 F 1163	J.2		12 F 1138	J.2
	12 F 1165	J.2	26FC/1943	B.00105	J.2
	12 F 1167ND	J.2		12 F 1511	J.2
	12 F 1135	J.2	1653	12 FS 477A	J.1
	12 F 795A	J.2	1654	12 FS 533	J.1
	12 F 1395	J.2	26FC/5811	B.00163	J.3
			26FC/1838	A.00397A	J.2

## PAGE J.19

Ref. No.	Part No.	Plate No.	Ref. No.	Part No.	Plate No.
26FC/1839	A.00398A	J.2		12-2FS 33	J.2
26FC/1834	A.00801	J.2	573	12 F 315	J.2
26FC/1835	A.001006ND	J.2	1263	12-2FS 45	J.2
1567	12 FS 567A	J.2	575	12 FS 355	J.2
	12-2FS 37	J.2	1575	12 FS 565	J.2
	12-2FS 38	J.2		12-2FS 35	J.2
1927	12 F 949A	J.2		12-2FS 36	J.2
1928	12 F 950A	J.2	952	12 FS 525A	J.2
			953	12 FS 526A	J.2

## PAGE J.20

Ref. No.	Part No.	Plate No.	Ref. No.	Part No.	Plate No.
26FC/1829	A.00941	J.2	6039	12 F 829ND	J.1
6034	12 F 821ND	J.1	6036	12 F 825ND	J.1

## HAND INK ALTERATIONS

Insert in the "Plate No." Column the following plate numbers against the undermentioned Part Numbers :—

## PAGE JA.1

Ref. No.	Part No.	Plate No.	Ref. No.	Part No.	Plate No.
26FC/2882	A.002149	JA.1	26FC/2870	A.001687	JA.2
26FC/2883	A.002150	JA.1	26FC/2867	A.001684	JA.2
1585	12 F 913A	JA.1	26FC/2866	A.001683	JA.2
1580	12 FC 41A	JA.1	26FC/4448	A.007013	JA.2
	12 FC 11A	JA.1		12 FC 59	JA.2
1581	12 FC 49A	JA.1	26FC/2869	A.001686	JA.2
1582	12 FC 47A	JA.2	1587	12 FC 65A	JA.2
1583	12 FC 48A	JA.2		12 FC 61	JA.2
1586	12 FC 63A	JA.2	26FC/4273	A.004977A	JA.2
26FC/4449	A.007015	JA.2	26FC/3758	A.002333A/1	JA.2
26FC/2868	A.001685	JA.2	26FC/3757	A.002332A/1	JA.2

## PAGE JA.2

Ref. No.	Part No.	Plate No.	Ref. No.	Part No.	Plate No.
1584	12 FS 721A	JA.1		A.002206	JA.1
26FC/2887	A.002165A	JA.1	26FC/3798	A.004768	JA.1
26FC/6408	A.002662A	JA.1	26FC/2893	A.001675	JA.2
26FC/6404	A.002663	JA.1	26FC/2894	A.001676	JA.2
26FC/3797	A.004764A	JA.1		A.002767ND	JA.1
26FC/2891	A.001677A	JA.2		A.002213	JA.1
26FC/2892	A.001678A	JA.2	26FC/6727	12 FC 89A	JA.2
			26FC/3472	A.004769	JA.1

## PAGE JA.3

Ref. No.	Part No.	Plate No.	Ref. No.	Part No.	Plate No.
749	12 FS 381A	JA.1	26FC/4613	A.002331	JA.1
26FC/2901	A.002143	JA.1	26FC/4458	A.002330	JA.1
26FC/2902	A.002144	JA.1	26FC/2905	A.002321	JA.1
26FC/4206	A.002059A/2	JA.1	26FC/2906	A.002322	JA.1
26FC/2899	A.002323	JA.1	26FC/3442	A.004774A	JA.1
26FC/2900	A.002324	JA.1	26FC/4185	A.005189	JA.1
	A.002351ND	JA.1	26FC/4186	A.005190	JA.1
	A.002305ND	JA.1	26FC/4079	A.005006ND	JA.1
26FC/2904	A.002345	JA.1	26FC/4080	A.005007ND	JA.1

## PAGE JB.1

Ref. No.	Part No.	Plate No.	Ref. No.	Part No.	Plate No.
27S/135	SKEFKO I.132629	JB.1		12 FC 111	JB.2
	12 FC 151A/ND	JB.2		12 FC 157	JB.2
9800	12 FC 161A/ND	JB.2	8198	12 FC 105	JB.2
9783	FCT.92	JB.2	8199	12 FC 109	JB.2
9782	FCT.80	JB.2	8195	12 FC 121	JB.2
26FC/5686	A.00111	JB.1		12 FC 119ND	JB.2
26FC/4396	A.005265	JB.1		12 FC 143	JB.2
8194	12 FC 123A	JB.2		A.00113	JB.2
9799	12 FC 123A/1	JB.2	8201	12 FC 133	JB.2
	12 FC 141	JB.2		12 FC 125	JB.2
8197	12 FC 107	JB.2	8200	12 FC 115	JB.2
	12 FC 145ND	JB.2		A.00565A	JB.2
8196	12 FC 117	JB.2		A.001887ND	JB.2
			26FC/6698	MOLLART No. 01	JB.2

## RESTRICTED

Issued with AL/2

## PART 1

Venom FB Mk. 4

## HAND INK ALTERATIONS

Insert in the "Plate No." Column the following plate numbers against the undermentioned Part Numbers :-

## PAGE JB.2

Ref. No.	Part No.	Plate No.	Ref. No.	Part No.	Plate No.
8202	12 FC 135	JB.2	8203	12 FC 139	JB.2
26FC/2885	A.001673	JB.1	8204	12 FC 131	JB.2
26FC/2884	A.001674	JB.1	26FC/3075	A.004098A	JB.1
26FC/2907	A.002024A	JB.1	26FC/2914	A.002318A	JB.1
			26FC/2915	A.002320	JB.1

## PAGE JB.3

Ref. No.	Part No.	Plate No.	Ref. No.	Part No.	Plate No.
26FC/2300	A.00526A	JB.2	26FC/5385	A.004061	JB.2
	A.00527A	JB.2	26FC/2898	A.001665	JB.2
	A.00528	JB.2	1592	12 FC 75A	JB.2
	A.001887ND	JB.2		A.001667	JB.1
26FC/6698	MOLLART No. 01	JB.2		12 F 617	JB.1
	A.00531	JB.2		A.002673	JB.1
	A.00529	JB.2		A.001104	JB.2
	A.00530	JB.2	26FC/2920	A.002035A	JB.2
	A.00532	JB.2		A.002032A	JB.2
	A.002038ND	JB.2		A.001049	JB.2
	A.00848	JB.2		A.002031	JB.2
26FC/2299	A.00535	JB.2		A.001047	JB.2
26FC/2317	A.00536	JB.2	26FC/2313	A.001048	JB.2

## PAGE JB.4

Ref. No.	Part No.	Plate No.	Ref. No.	Part No.	Plate No.
26FC/3590	A.004192A	JB.1	2180	12 F 595A/ND	JB.1
	A.002037ND	JB.1	8207	12 FC 137	JB.2
2179	12 F 303A	JB.1		A.004121A	JB.1
2178	12 F 301A	JB.1	8205	12 FC 129	JB.2
26FC/2911	A.002001	JB.1	28R/13491	AS.107	JB.1
26FC/4464	A.001699	JB.1	26FC/2923	A.001693A	JB.1
26FC/2912	A.002005	JB.1	26FC/2924	A.001691	JB.1
758	A.004057	JB.1	26FC/2921	A.002004A	JB.1
759	A.001688	JB.1	26FC/2922	A.002003	JB.1

## PAGE JB.5

Ref. No.	Part No.	Plate No.	Ref. No.	Part No.	Plate No.
26FC/2925	A.002007A	JB.2	26FC/2908	A.002015	JB.1
26BY/14435	SEEGER	JB.2	8206	12 FC 127	JB.2
26FC/1672	K.00214	JB.2		A.00568A	JB.2
26FC/2325	K.00217 Mk. 2	JB.2		A.002783	JB.2
26FC/2323	K.00215	JB.2		A.004048A	JB.1
26FC/2324	K.00216	JB.2		A.004051	JB.1
26FC/2916	A.002036	JB.2		A.004052A	JB.1
26FC/2897	A.001666	JB.2	26FC/3625	A.004050	JB.1
	A.002675	JB.2		A.002893	JB.1
26FC/7121	A.004060	JB.2	26FC/2926	A.002176A	JB.1
26FC/3074	A.004091	JB.1	26FC/2927	A.002175	JB.1

## HAND INK ALTERATIONS

Insert in the "Plate No." Column the following plate numbers against the undermentioned Part Numbers :—

## PAGE JC.1

Ref. No.	Part No.	Plate No.	Ref. No.	Part No.	Plate No.
590	12 P 203	JC.1	6421	12 S 601A	JC.1
	12 F 615	JC.1	1018	12 S 765	JC.1
	Q.002053	JC.1	26FC/2629	Q.00521A	JC.1
26FC/2368	Q.00213	JC.1	26FC/2631	Q.00172	JC.1
	12 S 1683A	JC.1	26FC/2630	Q.00173	JC.1
	Q.002052	JC.1	26BY/1466	Q.95212	JC.1
26FC/2369	Q.002051	JC.1	26BY/1471	Q.98130	JC.1

## PAGE JC.2

Ref. No.	Part No.	Plate No.	Ref. No.	Part No.	Plate No.
26BY/5940	62417	JC.1	26FC/1851	A.00961A	JC.1
	Q.00814	JC.1	26FC/1850	A.00949	JC.1
26FC/2632	Q.00520A	JC.1		A.00947	JC.1
26FC/2631	Q.00172	JC.1		12 F 1155A	JC.1
26FC/2633	Q.00517	JC.1		12 F 1159	JC.1
26BY/1464	Q.9838	JC.1		A.007009	JC.1
26BY/1466	Q.95212	JC.1	2757	12 F 347ND	JC.1
26FC/2634	Q.00518	JC.1	886	12 S 641A	JC.1
26BY/1471	Q.98130	JC.1	7115	12 F 345ND	JC.1
26FC/2628	Q.00519	JC.1		12 F 23ND	JC.1
	Q.00814	JC.1	3646	12 F 191A	JC.1
3647	12 F 475A	JC.1			

## PAGE JC.3

Ref. No.	Part No.	Plate No.	Ref. No.	Part No.	Plate No.
26FC/1884	A.00704	JC.1	6410	12 CF 483	JC.1
	12 CE 43	JC.1	6411	12 CF 485	JC.1
1133	12 P 307A	JC.1		12 CF 487	JC.1
	12 CF 535	JC.1		12 CF 489	JC.1
	12 CF 537	JC.1		12 CE 45	JC.1
			5254	12 CE 99	JC.1

## PAGE JD.1

Ref. No.	Part No.	Plate No.	Ref. No.	Part No.	Plate No.
6669	12 FS 905A/1	JD.1	2183	12 FS 53A	JD.2
6667	12 FS 205A/5	JD.1	2184	12 FS 54A	JD.2
26FC/899	A.001137A	JD.1	3664	12 FS 41A	JD.2
1478	12 F 269A	JD.2	3665	12 FS 42A	JD.2
3668	12 F 275	JD.2	26FC/3023	S.00299A	JD.1
1307	12 FS 313	JD.2	26FC/3024	S.00300A	JD.1
597	12 FS 39	JD.1	26FC/3025	S.00311A	JD.1
596	12 FS 37	JD.1	26FC/3026	S.00312A	JD.1

## RESTRICTED

Issued with AL/2

## PART 1

Venom FB Mk. 4

## HAND INK ALTERATIONS

Insert in the "Plate No." Column the following plate numbers against the undermentioned Part Numbers :-

## PAGE JD.2

Ref. No.	Part No.	Plate No.	Ref. No.	Part No.	Plate No.
26FC/6958	12 A 521A	JD.1	26FC/11776	3 EC 1173	JD.2
26FC/6959	12 A 522A	JD.1		12 F 265ND	JD.2
26FC/6960	12 A 525A	JD.1	26FC/1532	L.00109	JD.2
26FC/6961	12 A 526A	JD.1		12 F 155ND	JD.2
740	12 F 135A	JD.2	747	12 FS 371ND	JD.2
744	12 F 321A	JD.2		G.00559	JD.2
741	12 F 147	JD.2	26FC/1917	G.00557A	JD.1
3666	12 F 151	JD.2		A.00339	JD.1
742	12 F 149	JD.2		A.00340	JD.1
743	12 F 267ND	JD.2		A.007367	JD.2

## PAGE JD.3

Ref. No.	Part No.	Plate No.	Ref. No.	Part No.	Plate No.
	A.007368	JD.2		A.00335	JD.1
	A.00337	JD.1		A.00336	JD.1
	A.00338	JD.1	26FC/1961	G.00554A	JD.1
			26FC/915	G.00558A	JD.1

## PAGE JE.1

Ref. No.	Part No.	Plate No.	Ref. No.	Part No.	Plate No.
26FC/954	B.0056	JE.1		12 F 1049A/2	JE.1
26FC/953	B.0055	JE.1	6A/1319	†	JE.1
	B.00631	JE.1	6A/3147	†	JE.1
	B.00632	JE.1	6A/2717	†	JE.1
26FC/7977	B.002695A	JE.2	6A/3063	†	JE.1
10A/9335	LORD 150.P6	JE.2	6B/2035	†	JE.1
2379	12 F 1009A	JE.2	6A/2966	†	JE.1
	12-4F 31A	JE.1	6A/2945	†	JE.1
				12 F 1005A/2	JE.1

## PAGE JE.2

Ref No.	Part No.	Plate No.	Ref. No.	Part No.	Plate No.
6A/	W.6216/3	JE.1	6B/538	†	JE.1
26FC/5723	B.002687A	JE.1	8111	12 F 1021A	JE.1
6A/2519	W.6216/1	JE.1	5CZ/430	†	JE.1
	12 F 1619ND	JE.1	5CZ/432	†	JE.1
26FC/4741	B.002703ND	JE.1	5CZ/868	†	JE.1
2380	12 F 1051ND	JE.1		12 F 1023ND	JE.1
26FC/4743	B.002701ND	JE.1		12 F 1921A/2	JE.1
26FC/4744	B.002705ND	JE.1		12 S 1265	JE.2

## PAGE JE.3

Ref. No.	Part No.	Plate No.	Ref. No.	Part No.	Plate No.
6518	12 S 1267A	JE.2	5CX/4204	†	JE.1
10F/1786	†	JE.1		12 S 1501A/ND	JE.2
5L/X951273	†	JE.1	5063	12 S 1263	JE.2
5L/X951110	†	JE.1		12 S 1495	JE.2
5L/X951230	†	JE.1	5066	12 S 1367	JE.2
5L/X951232	†	JE.1		12 F 1307	JE.1
6A/2191	SANGAMO	JE.1		12 N 2015	JE.1
6A/2238	SMITHS 91 MV	JE.1		B.001063	JE.1
6A/2801	†	JE.1	26FC/941	L.00577	JE.1
6A/2136	SMITHS 114 FL	JE.1	26FC/947	B.000253	JE.1

## HAND INK ALTERATIONS

Insert in the "Plate No." Column the following plate numbers against the undermentioned Part Numbers :—

## PAGE JE.4

Ref. No.	Part No.	Plate No.	Ref. No.	Part No.	Plate No.
5CX/1553	†	JE.1	5CW/4226	†	JE.1
5CX/4192	†	JE.1	5CW/5502	THERMOL	JE.2
5CX/4191	†	JE.1	10L/246	†	JE.1
6A/2194	†	JE.1	27M/646	LOCKHEED	JE.2
5064	12 S 1257A	JE.2	6503	12 S 1315	JE.2
6504	12 S 1261	JE.2		12 F 1089A/ND	JE.1
	12 F 1919A/2	JE.1	1980	12 F 1085A	JE.1

## PAGE JE.5

Ref. No.	Part No.	Plate No.	Ref. No.	Part No.	Plate No.
6D/1587	†	JE.1		A.00119	JE.2
	12 F 1079A/1	JE.1	26FC/950	A.001117A	JE.2
6A/1588	SMITHS V.238	JE.1	26FC/951	A.001118A	JE.2
26FC/6680	B.002525	JE.1	26FC/938	A.001221	JE.2
26FC/937	A.001122A	JE.2	6A/2197	†	JE.1
26FC/949	A.001120A	JE.2	5L/X951230	†	JE.1
26FC/933	A.001098A	JE.1	6A/1862	†	JE.1
			6A/3863	GP.251/020	JE.1

## PAGE JE.6

Ref. No.	Part No.	Plate No.	Ref. No.	Part No.	Plate No.
	B.00948	JE.1	27F/2162	M.2601-Rotax	JE.1
5CX/1553	†	JE.1	5CW/4676	TEDDINGTON	JE.1
	12 F 1077A/3	JE.1		12 F 1061A/1	JE.1
26FC/935	B.0054A	JE.1	5L/X951230	†	JE.1
	12 F 1033	JE.1	26FC/4327	B.00375A/2	JE.1
	12 N 1355	JE.1	26FC/946	B.00252	JE.1

## PAGE JE.7

Ref. No.	Part No.	Plate No.	Ref. No.	Part No.	Plate No.
5CX/1553	†	JE.1		12 F 1125ND	JE.1
	12 F 1239	JE.1	26FC/924	B.0050A	JE.1
	B.00357ND	JE.1	26FC/925	B.0051A	JE.1
			26FC/4319	B.002919A	JE.1



This file was downloaded  
from the RTFM Library.

Link: [www.scottbouch.com/rtfm](http://www.scottbouch.com/rtfm)

Please see site for usage terms,  
and more aircraft documents.