

Appendix 5

ROTAX, TYPE C5600 SERIES

LIST OF CONTENTS

	Para.		Para.
<i>Introduction</i>	1	<i>Operation</i>	10
<i>Description</i>	2	<i>Installation</i>	11
<i>Motor and brake</i>	3	<i>Servicing</i>	12
<i>Gearbox</i>	6	<i>Brush gear</i>	14
<i>Mechanical stop and warning lamp switch</i> ...	7	<i>Switches</i>	15
<i>Clutch and limit switch assembly</i>	9	<i>General</i>	16

LIST OF ILLUSTRATIONS

	Fig.		Fig.
<i>Actuator, Type C5601</i>	1	<i>Typical output shaft cam profile</i>	4
<i>Sectional view of actuator, Type C5611</i>	2	<i>Typical wiring diagram</i>	5
<i>Adapter housing and visual indicator</i>	3		

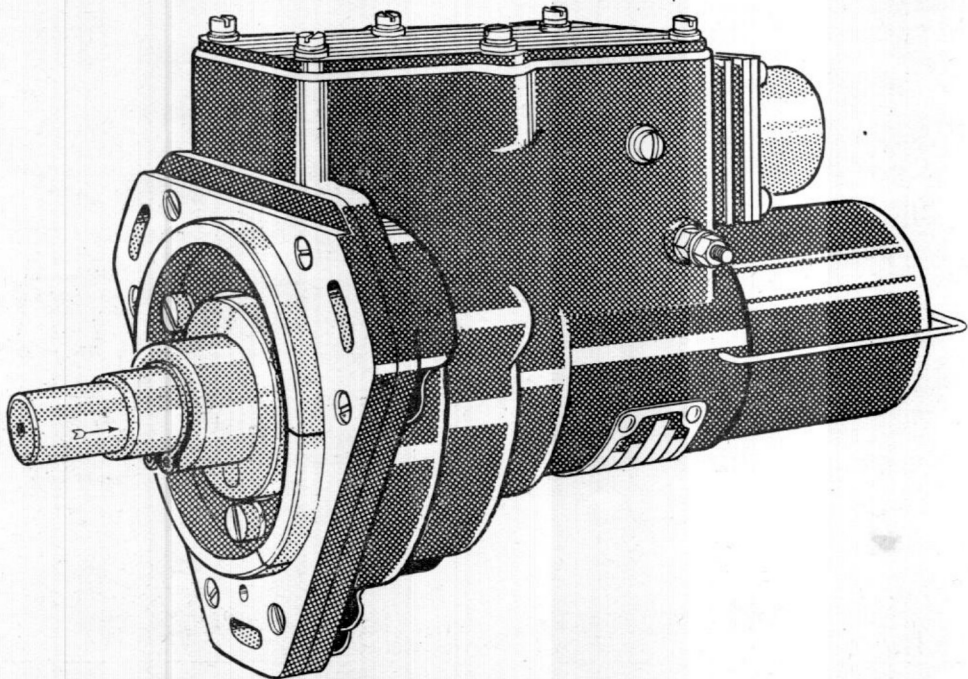

Fig. 1. Actuator, Type C5601

RESTRICTED

Introduction

1. The Type C5600 series of rotary actuators has been primarily designed for operation of large valves. The range covers a number of variations, which represent mainly different types of output shaft, differences in the range of angular travel and in the position of the Breeze plug. Information which applies to specific types will be found in A.P.4343D, Vol. 1, Sect. 16, and is additional to the information contained in the following paragraphs.

DESCRIPTION

2. The construction of the C5600 series of actuators is illustrated in fig. 1 and 2. Fig. 1 shows a Type C5601 actuator, and fig. 2 a C5611, which is typical of the series. Fig. 3 illustrates the adapter housing and visual indicator, which are fitted to some of the machines. The actuator incorporates a co-ordinated limit switch, clutch and stop mechanism set for the specific angular travel; it is not, however, designed for continuous inching.

Motor and brake

3. These actuators are of in-line design, and embody a reversible motor which drives an output shaft through a 4-stage epicyclic gear-

box. The motor is of 24-volt, split-series design, one field being used for clockwise and the other for anti-clockwise rotation. The yoke and pole-pieces are integral, being formed of a single set of laminations. Access to the brush gear is gained by removal of the brush cover, which is secured by a spring clip. Brush pressure is maintained by flat coiled springs operating on a trigger finger.

4. The solenoid-operated brake prevents rotation of the armature when the motor is switched off. The brake coil is connected in series with the armature, and when energized releases the brake against the normal spring tension. When the angular limit of rotation is reached, a snap-action limit switch is automatically operated by a revolving annulus and clutch mechanism.

5. The armature shaft runs in ball bearings, mounted in the commutator end frame and in a liner in the main housing. The brake plate has a slotted boss which is located on the end of the armature shaft; the cork-faced spring-loaded brake plunger is fitted in the commutator end frame in a brake coil cup, secured by two csk/hd. screws.

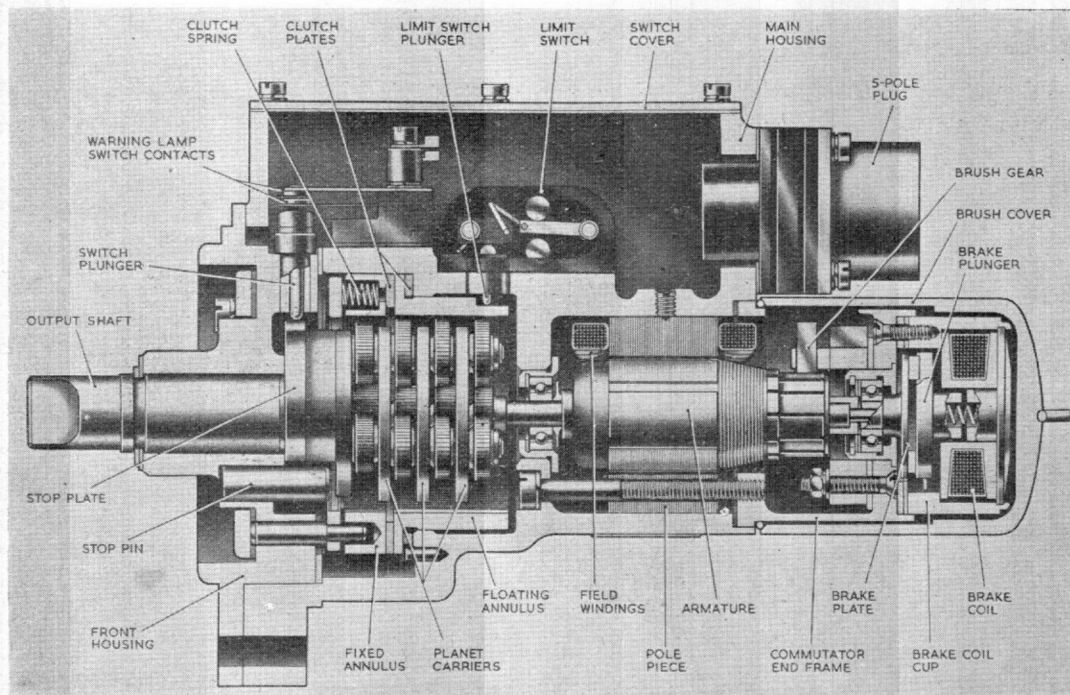

Fig. 2. Sectional view of actuator, Type C5611

RESTRICTED

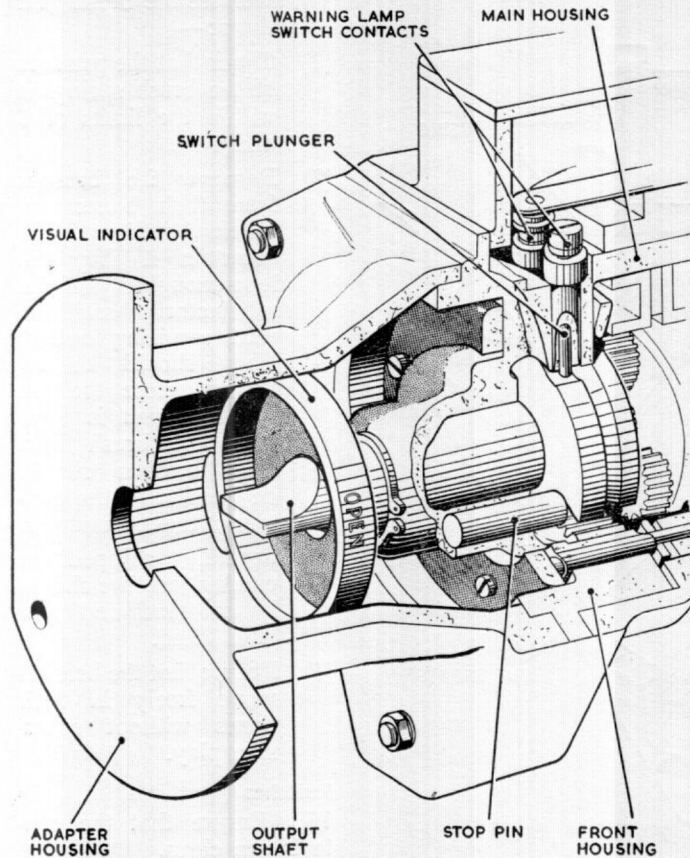

Fig. 3. Adapter housing and visual indicator

Gearbox

6. The 4-stage epicyclic gearbox has a reduction ratio of 749:1. It comprises first, second, and third planetary trains, each consisting of a planet carrier and sun gear assembly, fitted with three planet pins on which the planet gears are mounted. The first three trains run inside a floating annulus, aligning with a bronze spindle which passes through the centre. The fourth planetary train, fixed to the output shaft, runs inside a fixed annulus.

Mechanical stop and warning lamp switch

7. A stop plate and three planet pins are assembled to the output shaft, which is secured by a circlip and mounted in a plain bearing in the front housing. The required angular travel is determined by a stop pin pressed into the front housing, which operates in a cut-away portion of the lower periphery of the stop plate.

8. At the opposite side of the stop plate is a cam formation, against which bear two spring-loaded plungers (fig. 4). As the output shaft nears the end of its angular travel in one direction, the cam profile on that side raises the appropriate plunger, and closes the switch contacts to complete the circuit to the warning lamp. As the output shaft rotates in the opposite direction, the first switch contacts are opened, and at the end of the travel period the other plunger is raised by the cam profile at the other side. In each instance, the warning light operates 8 to 10 deg. before the end of the shaft travel. A circuit diagram is given in fig. 5.

Note . . .

This paragraph is not true for Types C5605, C5609, and C5610, which have only a single pair of warning light contacts.

Clutch and limit switch assembly

9. Eighteen clutch springs in the fixed annulus apply pressure to two phosphor-bronze clutch plates, between which the flange on the floating annulus is held. The limit switch is operated by a cam formation on the floating annulus. When the output shaft reaches the end of its angular travel and is prevented by the stop pin from rotating further, rotation of the floating annulus brings the raised portion of the cam profile beneath the spring-loaded plunger, so actuating the snap-action limit switch to change the electrical supply to the other motor field.

OPERATION

10. When one field of the actuator is energized, the solenoid brake is released, and the motor rotates in the appropriate direction. When it reaches the end of its travel, the limit switch changes the supply to the other

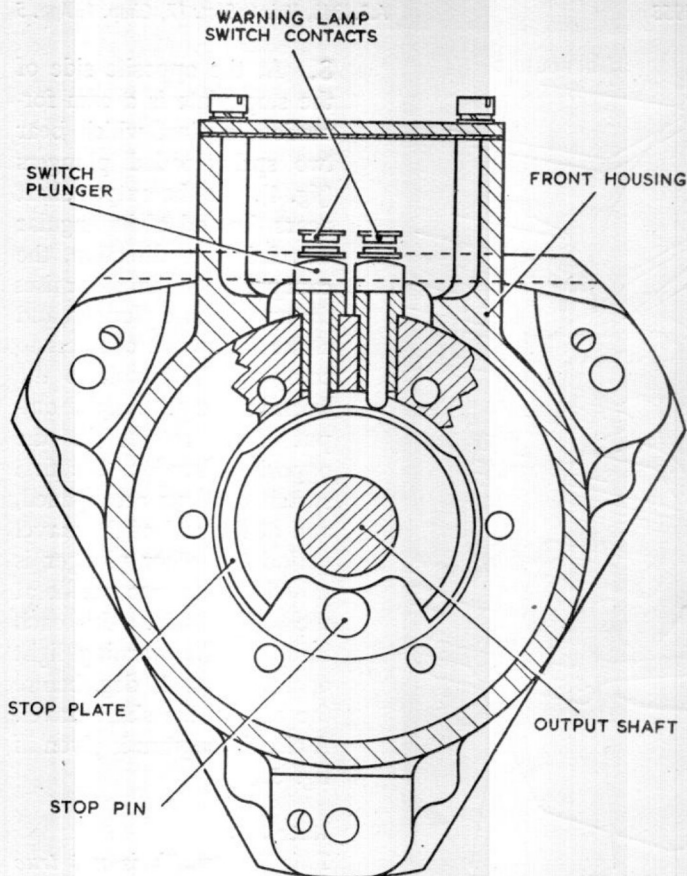

Fig. 4. Typical output shaft cam profile

field. The actuator is rated for 10 complete cycles of operation; it is not suitable for continuous inching.

INSTALLATION

11. Information on the installation of these actuators will be found in the relevant Aircraft Handbook. It is most important that the wiring is arranged to avoid the possibility of external short circuits which, in some types of installation, could cause oscillatory action of the actuator.

SERVICING

12. Normal servicing of these actuators will necessitate only the removal of the brush cover and the switch cover.

13. The actuators are lubricated during manufacture and major servicing, and should not need further lubrication.

Brush gear

14. Service the brush gear as follows:—

- (1) Check that the pressure of the brush springs is within the limits of 5 and 7 oz.
- (2) Remove the brushes from their boxes and check their lengths to ascertain if they are long enough to perform satisfactorily until the next servicing period. They should be renewed before the top of the brush is level with the brush box. New brushes should be bedded to the contour of the commutator.
- (3) Severely chipped or cracked brushes should be removed and new ones fitted.
- (4) Ensure that the brushes move freely in their boxes without excessive play.

Switches

15. Ensure that the contacts are clean.

General

16. Check the security of all the electrical leads and examine the insulation for fraying or damage. Check all nuts, screws and locking devices for security.

17. Examine the motor for any traces of oil. If any are apparent, the actuator must be renewed.

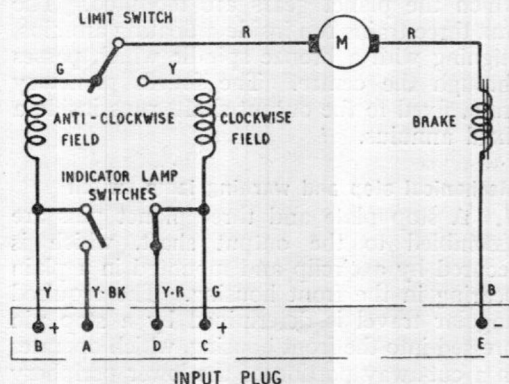

Fig. 5. Typical wiring diagram

RESTRICTED

This file was downloaded
from the RTFM Library.

Link: www.scottbouch.com/rtfm

Please see site for usage terms,
and more aircraft documents.



LIGHTNING MK. 1
COVER PITOT HEAD
EB2-88-5111