

Chapter 3

GRAVINER RESETTING FIRE DETECTORS

LIST OF CONTENTS

	<i>Para.</i>		<i>Para.</i>
<i>Introduction</i>	1	Operation	12
Description	2	Installation	15
<i>Series 3 detectors</i>	3	Servicing	17
<i>Series 4 detectors</i>	9	<i>Insulation resistance</i>	18

LIST OF ILLUSTRATIONS

	<i>Fig.</i>
<i>Typical Series 3 detector</i>	1
<i>Sectional view of Series 3 detector</i>	2
<i>Cover plate</i>	3
<i>Sectional view of Series 4 detector</i>	4

Introduction

1. The range of Gravier resetting fire detectors are thermally-operated switches, intended for use in potential fire zones. Individual detectors, which are described in A.P.4343E, Vol. 1, Sect. 14, are set to a specific operating temperature; if the ambient temperature in the zone rises above that figure, the detector

contacts close and complete an external circuit. The contacts reset to break the circuit when the ambient temperature falls below the operating setting.

DESCRIPTION

2. There are two groups of detector, Series 3 and Series 4, each covering a certain range of operating temperature settings. Series 3 are suitable for lower temperatures, up to 330 deg. C.; Series 4 differ slightly in internal construction, and are suitable for higher temperatures. The series is indicated in the manufacturer's type number, which has the suffix /3 or /4 as appropriate.

Series 3 detectors

3. A typical detector of this range, the 42D/3, is illustrated in fig. 1. It consists essentially of a temperature sensitive element mounted inside an expansion

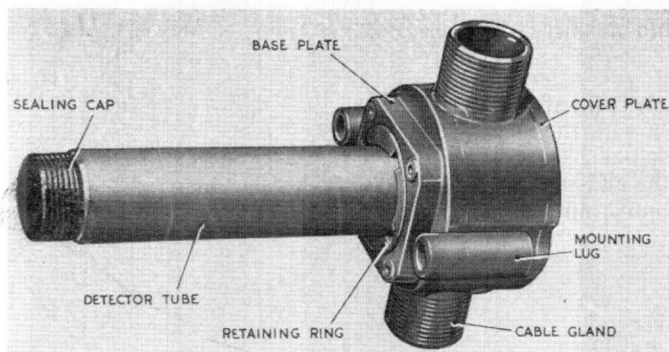

Fig. 1 Typical Series 3 detector

sion tube. Two electrical leads from the contacts of the element are connected to terminals in the base of the detector.

4. The element (*fig. 2*) consists of two silver rhodium contacts secured at the centre of a pair of nickel-iron spring bows. The spring bow assembly has a low co-efficient of expansion and is anchored to both ends of the expansion tube. The spring bows are held in the required position, with the contacts open, by a calibrating sleeve screwed into the end plug at the top end of the tube.

5. The calibrating sleeve, which is secured by a lock-nut after the adjustment during manufacture, is enclosed by a brass sealing cap screwed on to the end plug and secured by crimping. The unit is thus completely sealed, and no dismantling is possible.

6. The detector tube is made of steel alloy with a high co-efficient of expansion. The upper end contains the calibration sleeve, and the lower end is secured in a recess in the top of the detector base by an externally threaded retaining ring.

7. The moulded terminal block, in which are inserted two 6 B.A. terminal studs, is secured to the under face of the base plate either by opposing pairs of ch/hd. screws and studs, or by four studs. Secured to the base plate is a cylindrical cover which encloses the terminal block, and is provided with two tubular mounting lugs and one or two threaded cable entries. Where one cable entry is provided, the position of the cover may be altered to suit a particular installation (*para. 14*). Where two entries are provided, handling is unnecessary, and the cover is therefore secured by brazing within a skirt on the base plate.

8. The terminal cover plate (*fig. 3*) is fitted with two captive nuts which engage with the studs projecting from the terminal block. A central boss carries a spring wire, the ends of which engage in the slots of the captive nuts to lock them after tightening.

Series 4 detectors

9. The mechanism of these detectors is similar to those of the Series 3 range, but incorporates a strengthened spring bow assembly, as can be seen in *fig. 4*, because of the higher

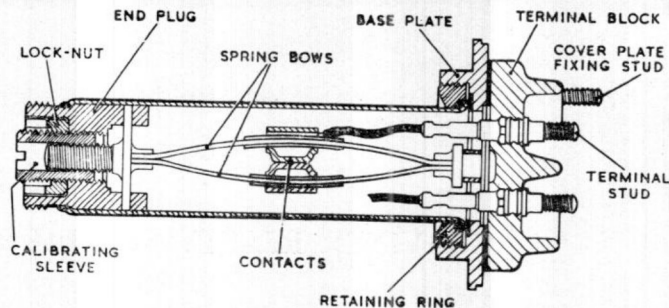

Fig. 2 Sectional view of Series 3 detector

operating temperature. In some detectors the mounting arrangements differ, having a three-hole flange mounting instead of tubular lugs.

10. 4 B.A. terminal studs are fitted, having shouldered terminal nuts with a 6 B.A. hexagon to minimize the possibility of damaging the terminal block moulding when tightening the nuts. The terminal cover plate is fitted with a mica lining.

11. The detector illustrated in *fig. 4* has a brass sealing cap with fibre washer, similar to that in Series 3 detectors (*para. 5*); in certain later types a more robust sealing cap, of knurled machined steel construction and having a copper washer, is fitted.

OPERATION

12. The operation of the detector is dependent upon the relative co-efficient of expansion of the tube and the spring bows. The co-efficient of expansion of the tube is high, and

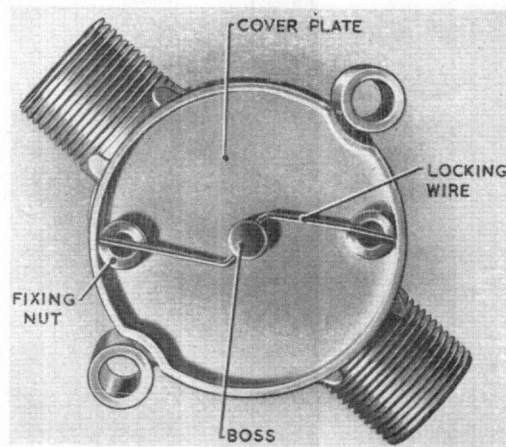

Fig. 3 Cover plate

RESTRICTED

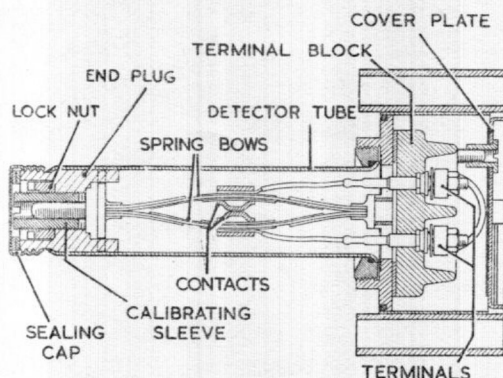

Fig. 4 Sectional view of Series 4 detector

that of the spring bows is low. Hence if both are heated at the same rate, the tube will expand more than the bows. As a result, the compressive force on the latter will be reduced and the contacts will eventually close at the setting temperature. A subsequent fall in temperature contracts the tube to a greater extent than the bows, and the contacts are thus reopened.

13. Operation at the setting, when both the tube and bows are heated at the same rate, will occur only if the rate of temperature rise is negligibly small. A fire in the detector zone giving a higher rate of temperature rise, and the effect of a heated airflow over the detector, will heat the tube at a faster rate than the bows. As a result the contacts will close at a temperature below the setting.

14. With Series 3 detectors, if the rate of temperature rise is in excess of 60 deg. per minute, with a heated airflow of about 80 knots, the detector contacts will close at approximately 40 deg. C. below the set

operating temperature. With Series 4 detectors, under conditions of rapid temperature rise the contacts may close about 60 deg. below the set temperature.

INSTALLATION

15. The tubular type of mounting lugs are suitable for 2 B.A. bolts, and the detector may be mounted in any position. Details of the installation in a particular aircraft will be found in the relevant Aircraft Handbook.

16. When installing detectors with a single cable entry the cover should first be fitted to suit the installation. The cover is the correct way round when, viewed from the bottom, the cable entry is in line with the central barrier projecting from the terminal block moulding, and when the mounting lugs are at right-angles to the cover plate securing studs. The cover plate may then be fitted with the indentations in its rim aligned with the mounting lugs.

SERVICING

17. Since the detector is locked and sealed during manufacture, no dismantling or adjustment is possible. A faulty detector should be rejected and a new one substituted. ◀ Apart from an examination to ensure that the unit is mechanically sound and undamaged, in situ servicing is restricted to continuity and insulation checks. ▶

Insulation resistance

18. The insulation resistance between the terminals and the base plate should be measured, using the standard 250-volt insulation resistance tester (Ref. No. 5G/152). ◀ The value obtained should be not less than 2 megohms. ▶

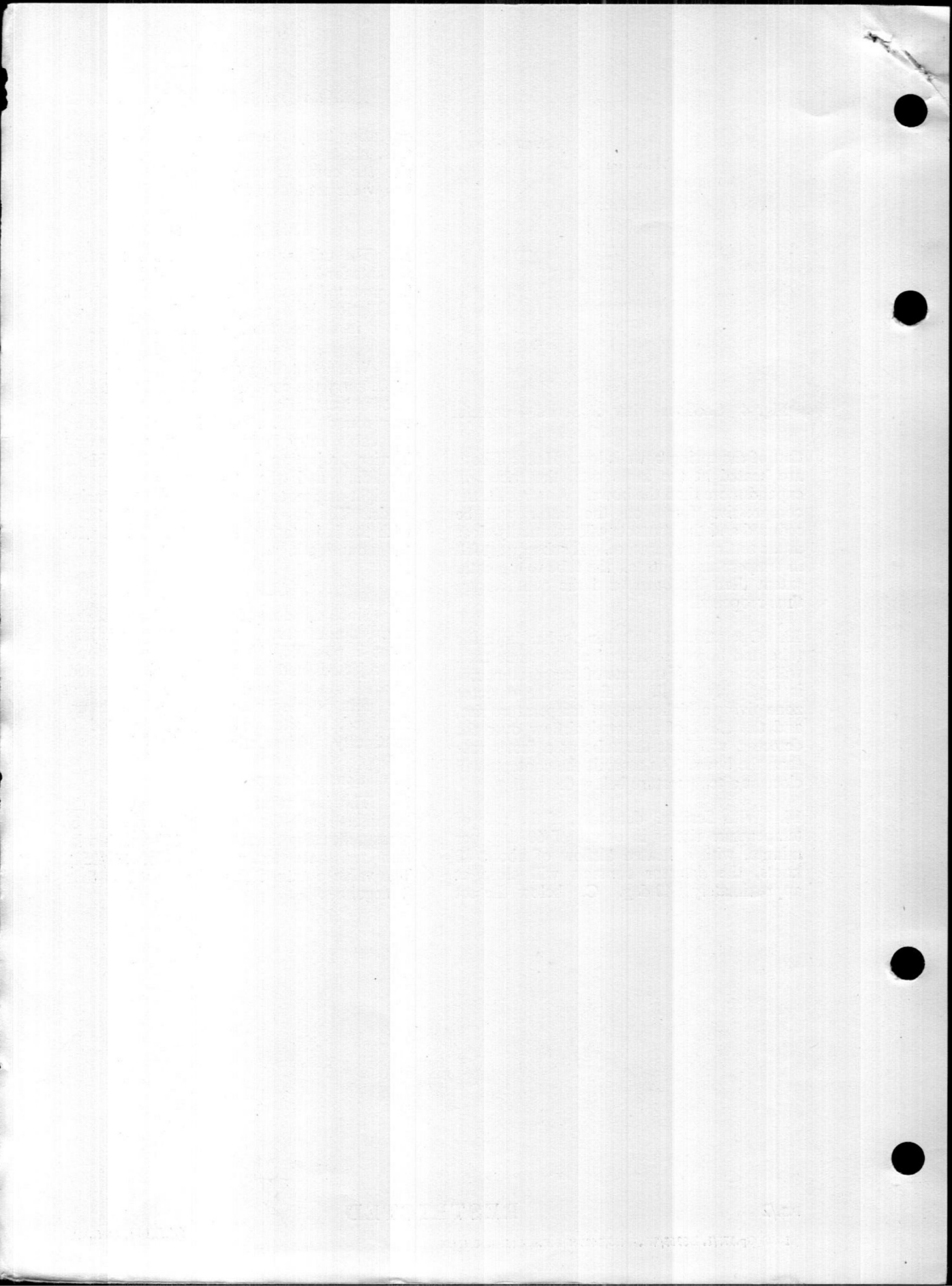

This file was downloaded
from the RTFM Library:

Link: www.scottbouch.com/rtfm

Please see site for usage terms,
and more aircraft documents.

