

Remove the capacitor

Chapter 4

VOLTAGE REGULATOR, TYPE 116

LIST OF CONTENTS

	Para.		Para.
Introduction	1	Regulation test	10
Description	2	Stability tests	11
Installation	7	Using the correct machine	12
Servicing	8	Using a machine of similar characteristics... ..	14
Testing		Setting of armature stop screw	17
General	9		

LIST OF ILLUSTRATIONS

	Fig.		Fig.
Voltage regulator, Type 116	1	Circuit diagram	4
Regulator unit	2	Test circuit diagram	5
Underside of regulator	3		

LEADING PARTICULARS

Voltage regulator, Type 116	Ref.No.5UC/6463
Controlled voltage	200 ± 8 volts
Maximum pile loading	10.5W
Pile resistance range	6.5 to 135 ohms
Operating coil current	0.07 to 0.077 amp.
Operating coil resistance	970 ohms
Fixed ballast resistor	1250 ohms, 12W
Adjustable ballast resistor	2 x 550 ohms
Trimmer diverter	600 ohms, 12W
Remote trimmer	600 ohms, 4W
Shunt stabilising winding	130 ohms
Capacitors	2 x 50 ufd
Rectifier	W.B. and S.Co. T15B/151 - 3 phase
Dimensions	6 ³ /32 x 5½ x 5 3/8
Weight	4¼ lb.

RESTRICTED

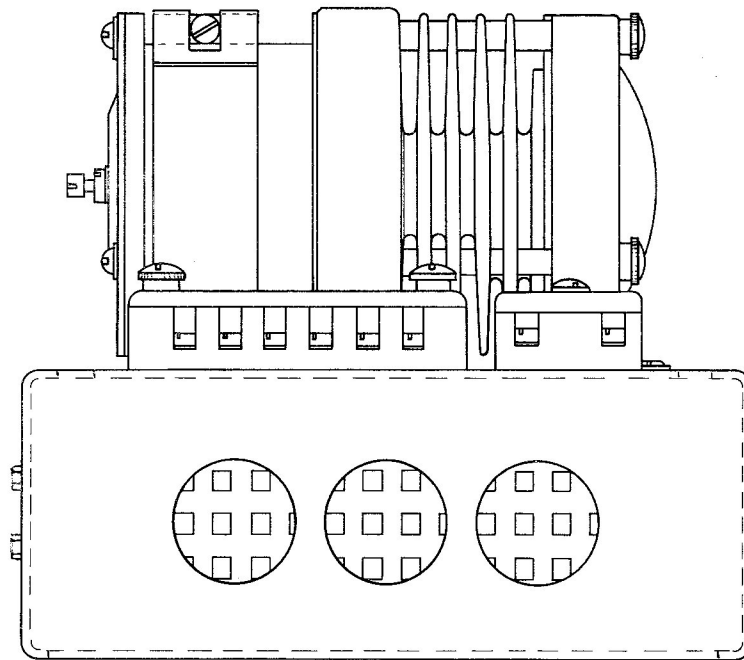

Fig.1 Voltage regulator, Type 116

Introduction

1. The voltage regulator, Type 116, is used to control the output of the a.c. generator Type 163 (E.E., Type AE.2034) at 200 ± 8 volts. The 200V, 3-phase, 400 c/s, a.c. output is rectified in the regulator, to supply the operating coil; the carbon pile is connected in series with the exciter field.

DESCRIPTION

2. The regulator (*fig.1*) is of the single carbon pile type, and in general construction and principle of operation is similar to the standard design as described in A.P.4343, Vol.1, Sect.6, Chap.2. The regulator incorporates a carbon pile, 1½ in. long, made up of not less than seventy six 0.5 mm. carbon washers.

3. The carbon pile is housed in a ceramic tube, which is a close fit in a cast finned

cooler, which dissipates the heat from the carbon pile.

4. The regulator unit (*fig.2*) is mounted on a base under which are housed the adjustable ballast, fixed ballast and trimmer diverter resistors, the rectifier and capacitors.

5. The operating coil is connected in series with the trimmer diverter and ballast resistors across the rectified output of the a.c. generator. The trimmer diverter resistor is connected through terminals 4 and 5 across the remote trimmer and associated wiring. This ensures that in the event of an open circuit of the remote trimmer or wiring, the voltage level is maintained within safe limits.

6. Voltage stabilising is assisted by the shunt stabilising winding embodied with the main operating coil and the two parallel

RESTRICTED

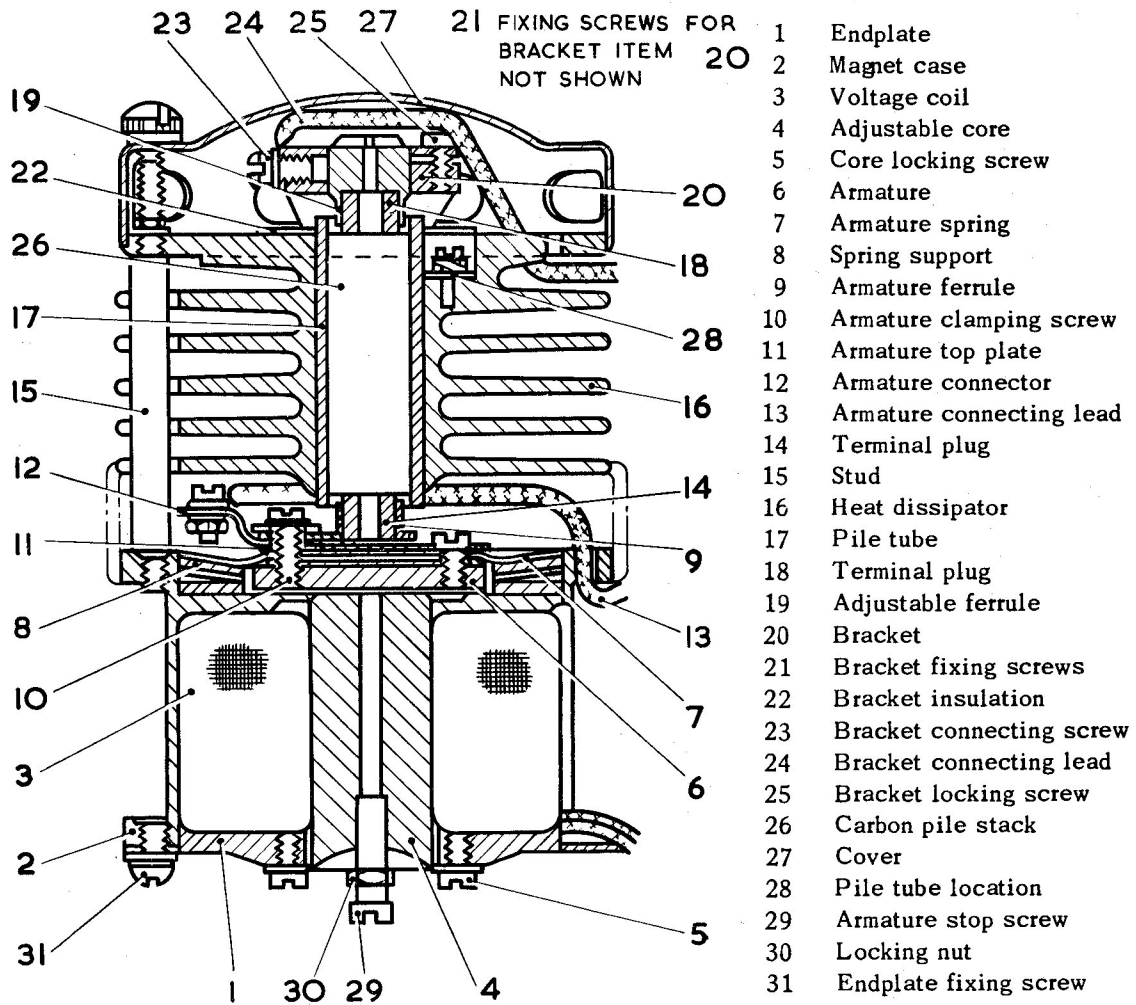

Fig.2 Regulator unit

connected capacitors. The stabilising winding is connected in series with the capacitors across the exciter output. This acts as a damping device and ensures a safe margin of stability under conditions of transients due to sudden changes of generator speed or load.

INSTALLATION

7. The regulator should be mounted with the axis of the carbon pile horizontal and the regulator base in the vertical phase.

It should be in such a position that there is no restriction of free circulating air through the finned cooler.

SERVICING

8. General servicing instructions for this type of regulator are given in A.P.4343 Vol.1, Sect.6, Chap.1 and 2. Information will be found in Chap.1 on changing the carbon pile, and on setting up a regulator which is completely out of adjustment. When any adjustments are made, the

RESTRICTED

regulator must afterwards be subjected to a full test.

TESTING

General

9. Connect the regulator to the test circuit, as shown in fig.5. It is desirable that the a.c. generator, Type 163 (E.E. Type AE.2034), should be used; if the correct machine is not available, tests should be made using a machine of substantially similar characteristics, and the stabilising winding disconnected for all tests. The regulator should be adjusted to control the generator output at 200V with the coil current adjusted within the limits of 0.07 - 0.077 amp. cold, with the trimmer in approximately the mid position.

Note...

Ensure that the armature stop screw is

turned out sufficiently to prevent any restriction in armature movement.

Regulation test

10. Run the generator at normal speed and, by variation of R1 and R2, smoothly increase the pile resistance, as measured by V_2/A_2 from 6.5 to 135 ohms, and then decrease to 6.5 ohms. Repeat this cycle, and observe that the controlled voltage is maintained within the limits of 200 ± 8 volts.

Note...

It is important that the diverter resistor R2 should always be switched in or out at its maximum value.

Stability tests

11. The procedure to be adopted for stability testing depends upon whether the correct a.c. generator or a generator of

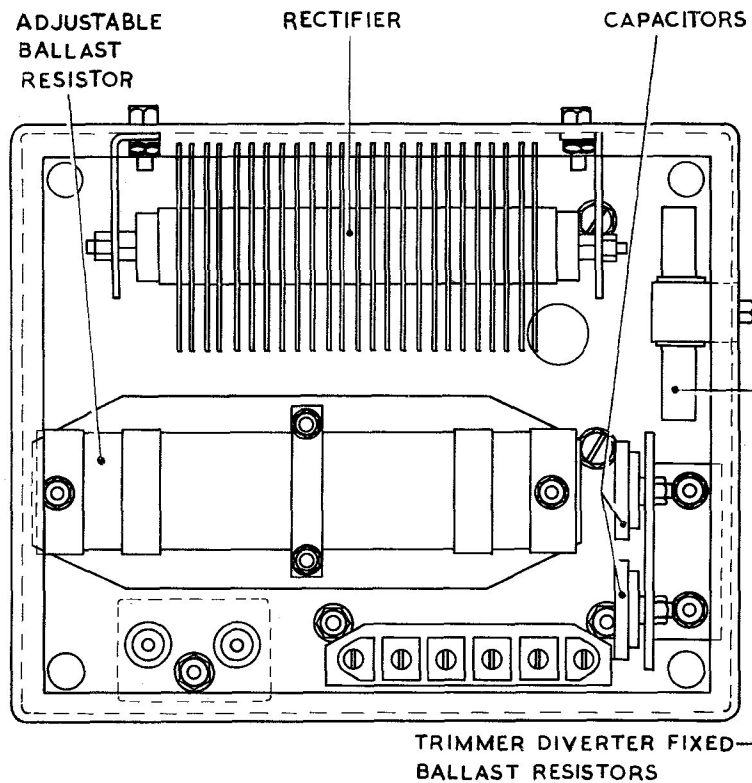

Fig.3 Underside of regulator

RESTRICTED

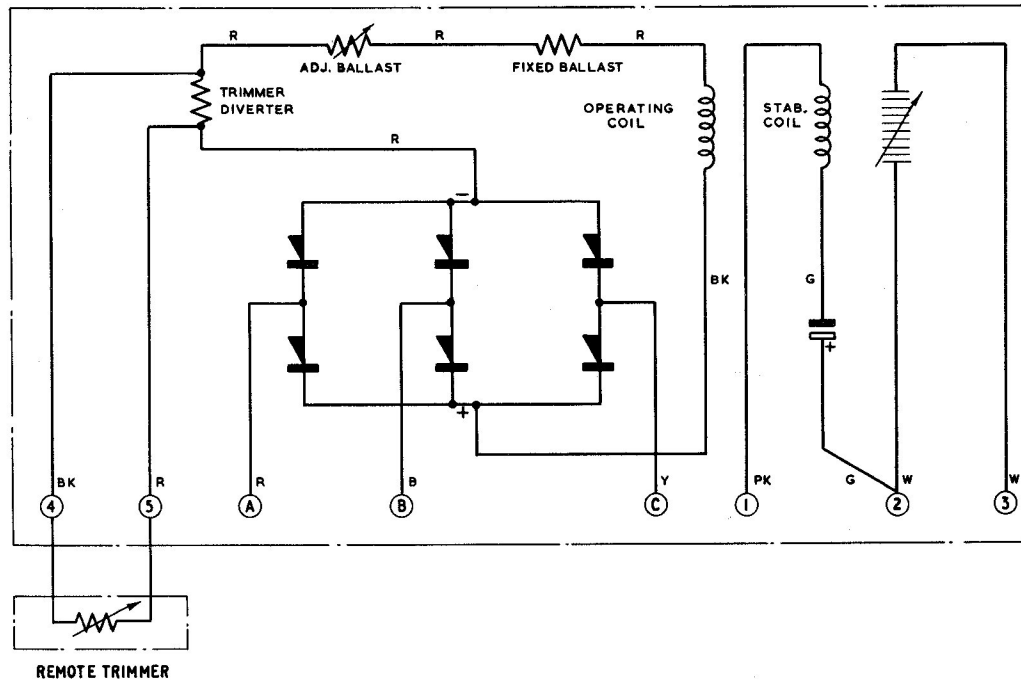

Fig.4 Circuit diagram

similar characteristics is used. Both methods are given in the following paragraphs.

Using the correct machine

12. Run the generator at maximum speed so that the carbon pile is operating at the maximum resistance of 135 ohms as measured by V2/A2. Switch the full generator load on and off at least three times. Under these conditions the regulator should be critically damped.

13. Following the test in para.12, turn the pile compression screw counter clockwise by $\frac{1}{4}$ turn and repeat the stability test. At this setting of the pile compression screw the regulator must respond without tendency to sustained hunting. Provided the regulator satisfies this test, the pile compression screw should be restored to its original setting and the regulation test para.10 repeated.

Using a machine of similar characteristics

14. When the test is performed with a

generator other than that of the correct type, the stabilising winding should be disconnected. Run the generator at a speed to give maximum pile resistance of 135 ohms, as measured by V2/A2; open generator field switch S2, and adjust series resistor R1 so that the pile resistance is at its minimum of 6.5 ohms; close generator field switch. The generator field should then be switched on and off at least three times. Under these conditions the regulator should be critically damped.

15. Following the test in para.14, turn the pile compression screw counter clockwise by $\frac{1}{8}$ turn, and repeat the stability test. At this setting of the pile compression screw, the regulator must respond without tendency to sustained hunting. Provided the regulator satisfies this test, restore the pile compression to its original setting and repeat the regulation test.

16. The stabilising winding should be tested for correct polarity as follows:—

RESTRICTED

This file was downloaded
from the RTFM Library.
Link: www.scottbouch.com/rtfm

Please see site for usage terms,
and more aircraft documents.

