

Fig. 1. Contact arrangement, MS 25125—1 to 9 series

DESCRIPTION

3. The bushing and lever-lock feature is of one piece construction, hence the name, integral, lever-lock design.

4. The contour at the top of the bushing (there is a rubber seal fitted between lever and bushing) is designed, so as to obtain the desired lever lock circuits, including locking against the momentary contact positions.

5. The switch is locked in position by the lever positively engaging in slots, milled in the top of the bushing.

Electrical details

6. The switch can be used as a single or double throw, with or without the centre "off" position. Momentary contact switches are normally 'open'. The current capacity of this type of toggle switch, when connected in a 28 Volt. d.c. or 115 Volt. a.c. circuit, under load, is shown in Table 1. Contact arrangements are shown in fig. 1.

Operation

7. To operate the lever from a locked position, it is necessary to exert an upward pull on the lever, so as to disengage it from the slot and then move it to the next position. When the switch has been moved to a

momentary position, it is only necessary to release the lever and it will automatically return and engage in the locked position.

INSTALLATION

8. For this one hole mounting switch, one hexagon nut is supplied, assembled to the bushing, face nut, internal tooth lockwasher, with locking supplied unassembled. An installation drawing is shown in fig. 2.

SERVICING

9. Little servicing should be necessary, except periodical inspection for signs of corrosion and cracks, and also for security of mounting and of the electrical connections.

TESTING

10. Check the switch for positive locking, this should prevent motion of the toggle lever in the direction indicated by the arrow (fig. 1), until the locking mechanism is manually released. The force required to release the locking mechanism is between 4 and 6 lb.

11. The toggle should withstand, without damage, a force of 25 lb. applied for one minute, co-axial with the lever axis and away from the pivot throughout the entire range of the lever.

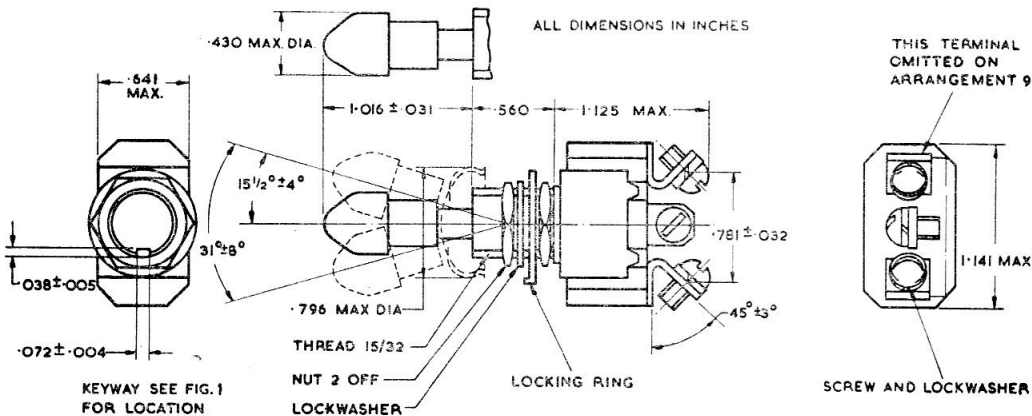

Fig. 2. Installation details

RESTRICTED

TABLE 1
Switch positioning and load details

M.S. Type switch Part No.	Ref. No. 5CW/	N.S.F. catalogue No. 8857/	Circuit with toggle in			Current capacity (amperes) per pole) 28 Volt. d.c.				Current capacity (amperes) 115 Volt. 400 cycles a.c.			
			One extreme position	Centre position	Other extreme position (keyway side)	Continuous	Lamp load circuit	Resistive circuit	Inductive circuit	Continuous	Lamp load circuit	Resistive circuit	Inductive circuit
25125-1		K-39	ON	OFF	ON	40	5	20	15	40	3	10	10
25125-2		K-40	ON	OFF	ON	40	5	20	15	40	3	10	10
25125-3		K-41	ON	OFF	ON	40	5	20	15	40	3	10	10
25125-4	7083	K-45	ON	NONE	ON	40	5	20	15	40	3	10	10
25125-5		K-42	ON	OFF	ON	40	5	20	15	40	3	10	10
25125-6		K-46	ON	OFF	MOM ON	40	4	15	10	40	2	10	7
25125-7		K-43	ON	OFF	ON	40	5	20	15	40	3	10	10
25125-8		K-44	ON	NONE	ON	40	5	20	15	40	3	10	10
25125-9	7729	K-49	ON	OFF	NONE	40	5	20	15	40	3	10	10

RESTRICTED

This file was downloaded
from the RTFM Library.

Link: www.scottbouch.com/rtfm

Please see site for usage terms,
and more aircraft documents.

